

A.J.S

SPARES LIST

for
1949

350 c.c. and 500 c.c.

49/16M, 49/16MC, 49/18 and 49/181C

O.H.V. A.J.S



A.J.S
MOTOR CYCLES
FRONTIER ASSOCIATED MOTOR CYCLES LIMITED
PLUMSTEAD - LONDON - S.E.18

*

Price
TWO SHILLINGS and SIXPENCE

EDITION CL.11

INDEX (SECTIONS)

	Page
ACCESSORY SECTION	44
CARBURETTOR SECTION	13
COMPETITION SPECIAL PARTS	45
CONTROL LEVER AND CABLE SECTION	31
ELECTRICAL SECTION	42
ENGINE SECTION	5
EXHAUST PIPE AND SILENCER SECTION	12
FRAME SECTION (INCLUDING FORK)	21
TANK SECTION	35
TRANSMISSION SECTION	15
WHEEL AND BRAKE SECTION	39

ILLUSTRATIONS

	Page
BRAKES	40
CARBURETTOR	14
CHAINCASES, SADDLE AND Pillion SEAT	28
CLUTCH AND KICK-STARTER	19
CONTROL LEVERS	32
ENGINE, FLYWHEEL, CYLINDER, HEAD AND PISTON	6
ENGINE, CRANKCASE, TIMING GEAR AND OIL PUMP	8
ENGINE, ROCKER BOX, EXHAUST PIPE AND SILENCER	10
FRAME AND FORK	24
GEARS	18
MUDGUARDS AND STANDS	26
TANKS, PETROL AND OIL PIPES	34
TRANSMISSION	16
WHEELS	38

See Inside of Rear Cover for Detailed Index

SPARES LIST

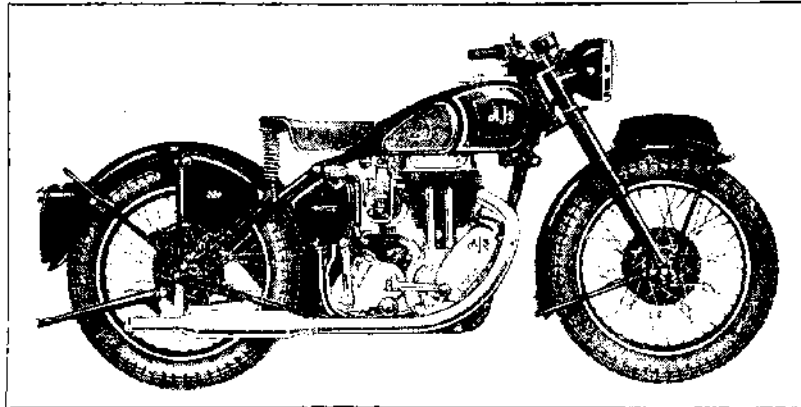

1949 A·J·S MODELS

350 Models 49.16M and 49.16MC

Bore 69 mm. Stroke 93 mm. Capacity 347 c.c.

500 Models 49.18 and 49.18C

Bore 82.5 mm. Stroke 93 mm. Capacity 498 c.c.

STANDARD
COMPEITION
COMPEITION
WITH
SWINGING
HEAD

A·J·S

Compiled and Issued by the Manufacturers :

A·J·S MOTOR CYCLES

(Proprietors: ASSOCIATED MOTOR CYCLES LIMITED)

Registered Offices :

**PLUMSTEAD ROAD, PLUMSTEAD
LONDON, S.E.18 .. ENGLAND**

Nearest Station :
WOOLWICH ARSENAL.
(Southern Region Railway)

Factories :
**BURRAGE GROVE and MAXEY ROAD
PLUMSTEAD, S.E.18**

Telegrams and Cables : "ICANHOPIT-WOL-LONDON"

Telephone: WOOLWICH 1223 (5 Lines)

Codes : A.B.C. 5th and 6th Edition; Bentley's; and Private Codes

All correspondence to:-

A·J·S MOTOR CYCLES, PLUMSTEAD ROAD, LONDON, S.E.18

KLG FES0 = N3 = B7HS

Price: TWO SHILLINGS and SIXPENCE

EDITION CL-11

ENGINE SECTION.

PART NUMBER.	DESCRIPTION.	QTY.	USED ON.	PRICE EACH	
				£	s. d.
013791	Barrel, cylinder	1 ...	350 ...	3	6 0
013942	Barrel, cylinder.....	1 ...	500 ...	4	2 6
38-G9-E3-P	011191 Plate, compression, cylinder barrel base.....	1 ...	500 ...		2 10
39-8-E3	010927 Washer, paper, cylinder base.....	1 ...	All ...		3
39-8-E3	010927 Washer, paper, compression plate	1 ...	500 ...		3
STD-217 Nut, retaining cylinder to crankcase	4 ...	All ...		7

CYLINDER.

CYLINDER HEAD.

014571	Head, cylinder, with valve guides.....	1 ...	350 ...	5	7 3
014572	Head, cylinder, with valve guides.....	1 ...	500 ...	5	15 6
013922	Head, cylinder, less valve guides.....	1 ...	350 ...	4	19 0
013955	Head, cylinder, less valve guides.....	1 ...	500 ...	5	7 3
013793	Gasket, cylinder head.....	1 ...	All ...		1 4
39-8-E89 Bolt, securing head to barrel	4 ...	All ...		1 4
STD-10	Washer, plain, head securing bolt	4 ...	All ...		1
STD-291	Stud, fixing carburetter.....	2 ...	All ...		4
STD-4	Nut, carburetter stud	2 ...	350 ...		3
STD-74	Nut, carburetter stud	2 ...	500 ...		3

ENGINE VALVES.

013985	Valve, inlet.....	1 ...	350 ...	10	8
013988	Valve, inlet.....	1 ...	500 ...	14	0
013986	Valve, exhaust.....	1 ...	350 ...	12	4
013989	Valve, exhaust.....	1 ...	500 ...	14	0
010392	Spring, for valve, left position	2 ...	All ...		6 6
010004	Spring, for valve, right position	2 ...	All ...		6 6
013990	Collar, valve spring.....	2 ...	All ...		4 3
010017	Seat, valve spring.....	2 ...	All ...		3 3
STD-686	Collet, for valve. (Each in two pieces)	2 ...	All ...		1 2
39-12-E148 Guide, for inlet valve	1 ...	All ...		4 1
014510	Guide, for exhaust valve (1).....	1 ...	All ...		4 1

NOTE 1.—Guide 014510, if not available, can be replaced by guide 39-12-E148

PISTON.

013625	Piston, complete (2)	1 ...	350 ...	1	9 3
013626	Piston, complete (2)	1 ...	500 ...	1	17 3
013504	Piston, bare.....	1 ...	350 ...	18	1
013505	Piston, bare.....	1 ...	500 ...	1	4 9
D3-E311	Ring, compression, 2 $\frac{3}{8}$ in. by $\frac{1}{8}$ in.	2 ...	350 ...		1 6
D5-E611	010636 Ring, compression, 3 $\frac{1}{2}$ in. by $\frac{1}{8}$ in.	2 ...	500 ...		1 9
38-G3-E111 Ring, scraper, 2 $\frac{3}{8}$ in. by $\frac{1}{8}$ in.	1 ...	350 ...		2 3
36-G8-E111	010637 Ring, scraper, 3 $\frac{1}{2}$ in. by $\frac{1}{8}$ in.	1 ...	500 ...		2 9
D3-E1614 Pin, gudgeon	1 ...	350 ...		4 11
D5-E614	010651 Pin, gudgeon	1 ...	500 ...		5 3
STD-750	Circlip, for gudgeon pin.....	2 ...	All ...		6

The following oversize parts can be supplied.

013623	Piston, complete, -020 in. oversize (2).....	1 ...	350 ...	1	9 3
013624	Piston, complete, -020 in. oversize (2).....	1 ...	500 ...	1	17 3
013621	Piston, bare, -020 in. oversize.....	1 ...	350 ...	18	1
013622	Piston, bare, -020 in. oversize.....	1 ...	500 ...	1	4 9
o/D3-E311 Ring, compression, 2 $\frac{3}{8}$ + 020 in. by $\frac{1}{8}$ in.	2 ...	350 ...		1 6
o/D5-E611	013661 Ring, compression, 3 $\frac{1}{2}$ + 020 in. by $\frac{1}{8}$ in.	2 ...	500 ...		1 9
o/38-G3-E111 Ring, scraper, 2 $\frac{3}{8}$ + 020 in. by $\frac{1}{8}$ in.	1 ...	350 ...		2 3
o/36-G8-E111	013662 Ring, scraper, 3 $\frac{1}{2}$ + 020 in. by $\frac{1}{8}$ in.	1 ...	500 ...		2 9

NOTE 2.—"Piston, complete" includes—Piston, two compression rings, one scraper ring, gudgeon pin and two circlips

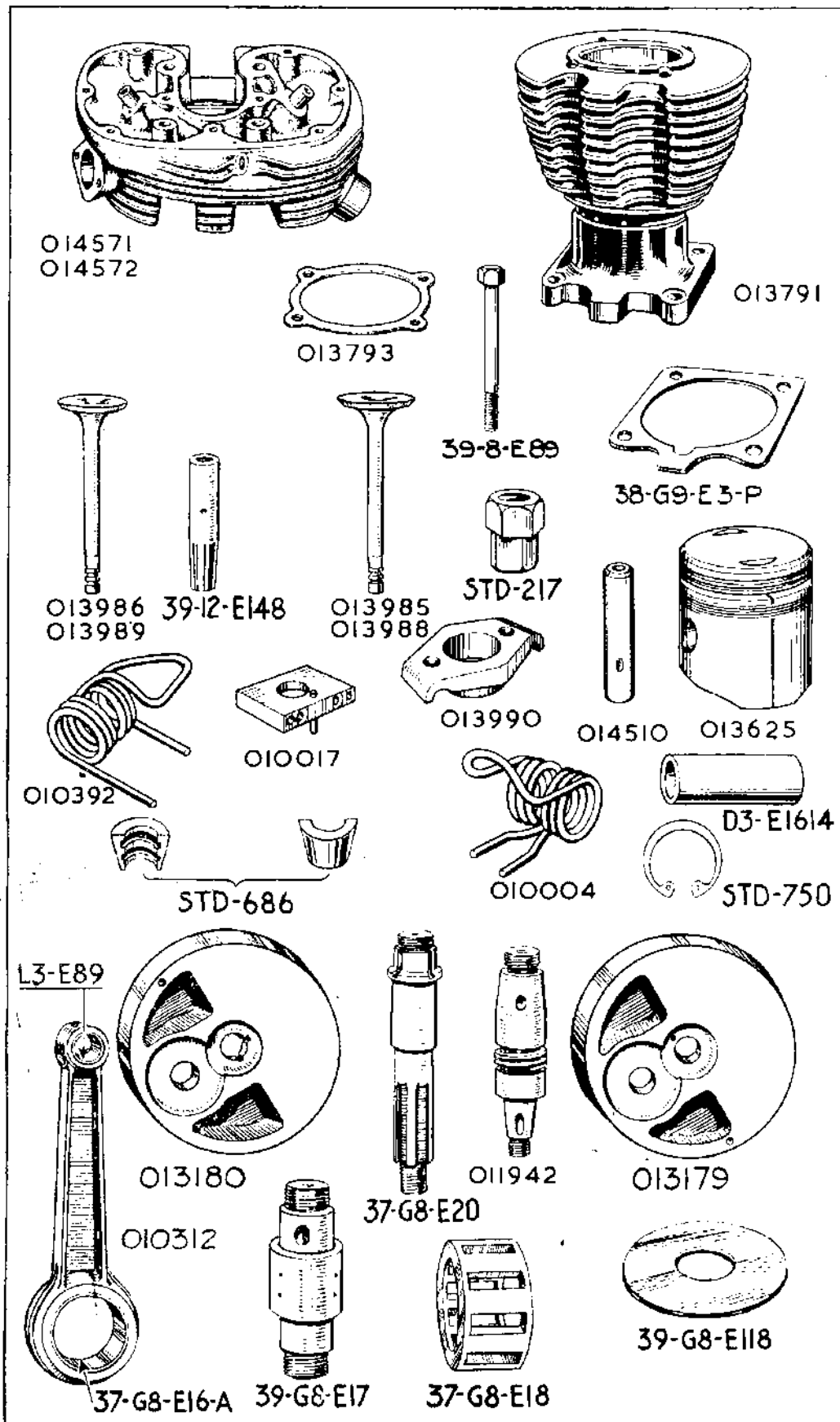

This scan is explicit for non-commercial use and is not intended for financial or material gain by anyone

PART NUMBER.	PART		DESCRIPTION.	QTY.	USED ON.	PRICE EACH
	OLD	NEW				

RE-BORING.

Cylinders may be re-bored to .020 in. oversize and pistons (with rings) supplied to suit.

350 Model ... £2 5s. 0d. ... (New gudgeon pin and circlips 5s. 11d. extra.)

500 Model ... £2 12s. 9d. ... (New gudgeon pin and circlips 6s. 3d. extra.)

Cylinders sent for re-boring should be packed in stout cases which will be used by us for their return. Carriage is additional. If a complete machine, or engine, is sent to us for cylinder re-boring, there will be an additional charge, according to the time taken for dismantling and assembly.

FLYWHEELS.

013180	Flywheel, bare, driving side.....	1	...	350	...	1	4	9
013179	Flywheel, bare, timing side.....	1	...	350	...	1	4	9
39-G9-E19	...	010935	Flywheel, bare, driving side.....	1	...	500	...	1	4	9
39-G9-E25	...	010936	Flywheel, bare, timing side.....	1	...	500	...	1	4	9
011942	Axle, timing side flywheel.....	1	...	All	...		15	0
37-G8-E20	Axle, driving side flywheel.....	1	...	All	...	1	7	6
STD-573	Key, driving side flywheel axle.....	2	...	All	...			4
STD-230	Nut, timing side flywheel axle.....	1	...	All	...			7
STD-234	Nut, driving side flywheel axle (special steel).....	1	...	All	...	1		3
STD-15	Screw, lock, timing side flywheel axle nut.....	1	...	All	...			1

CONNECTING ROD.

010312	Rod, connecting, with liner and bush.....	1	...	All	...	1	18	9
37-G8-E16-A	Liner, for big-end bearing.....	1	...	All	...		7	5
L3-E89	Bush, for gudgeon pin.....	1	...	All	...		4	4
STD-75	Roller, crankpin, $\frac{1}{2}$ in. by $\frac{1}{2}$ in.....	30	...	All	...			3
37-G8-E18	Cage, for crankpin rollers.....	1	...	All	...		12	4
39-G8-E17	Crankpin.....	1	...	All	...		17	4
39-G8-E118	Washer, for crankpin.....	2	...	All	...		1	7
STD-233	Nut, for crankpin (special steel).....	2	...	All	...		1	4

The following oversize part can be supplied but we recommend only skilled mechanics should fit same because it is almost general that the big-end journals and sleeves require "lapping" to ensure a correct fit.

O/STD-75	Roller, crankpin, $\frac{1}{2} + .001$ in. dia. by $\frac{1}{2}$ in. long.....	30	...	All	...			3
----------	-----	-----	--	----	-----	-----	-----	--	--	---

CRANKCASE.

014853	Crankcase, complete (3).....	1	...	All	...	8	0	10
39-8-E30	...	010937	Crankcase, driving side only (3).....	1	...	All	...	3	18	4
014854	Crankcase, timing side only, with bushes (3).....	1	...	All	...	4	2	6
STD-575	Plug, drain, for crankcase.....	1	...	All	...			6
STD-485	Screw, plug, for crankcase oil holes.....	3	...	All	...			1
STD-203	Washer, fibre, for oil hole screws.....	3	...	All	...			1
STD-576	Plug, for cylinder oil feed valve.....	1	...	All	...			4
010934	Body, for cylinder oil feed valve.....	1	...	All	...	1		3
STD-21	Ball, for cylinder oil feed valve.....	1	...	All	...			1
STD-701	Spring, for cylinder oil feed valve.....	1	...	All	...			3
STD-300	Stud, for cylinder base.....	4	...	All	...			4
010770	Cover, timing gear, with bushes.....	1	...	All	...	1	8	7
37-8-E78	Washer, paper, timing gear cover.....	1	...	All	...			3
STD-577	Peg, dowel, locating timing gear cover.....	2	...	All	...			1
STD-765	Cap, in timing gear cover, for cam bush.....	1	...	All	...			4
STD-482	Screw, fixing timing gear cover.....	5	...	All	...			3
38-22-E29	Cover, magneto chaincase.....	1	...	All	...	10		8
455	Screw, fixing magneto chaincase cover.....	6	...	All	...			3
STD-51	Nipple, grease, magneto chaincase cover.....	1	...	All	...			3

NOTE 3.—"CRANKCASE, COMPLETE" includes all bushes, the cylinder base studs and ball valve assembly, but does not include timing gear and magneto chain covers. Halves of crankcases must be matched in the Factory. Therefore it is necessary to send the sound half of a crankcase when ordering a new half.

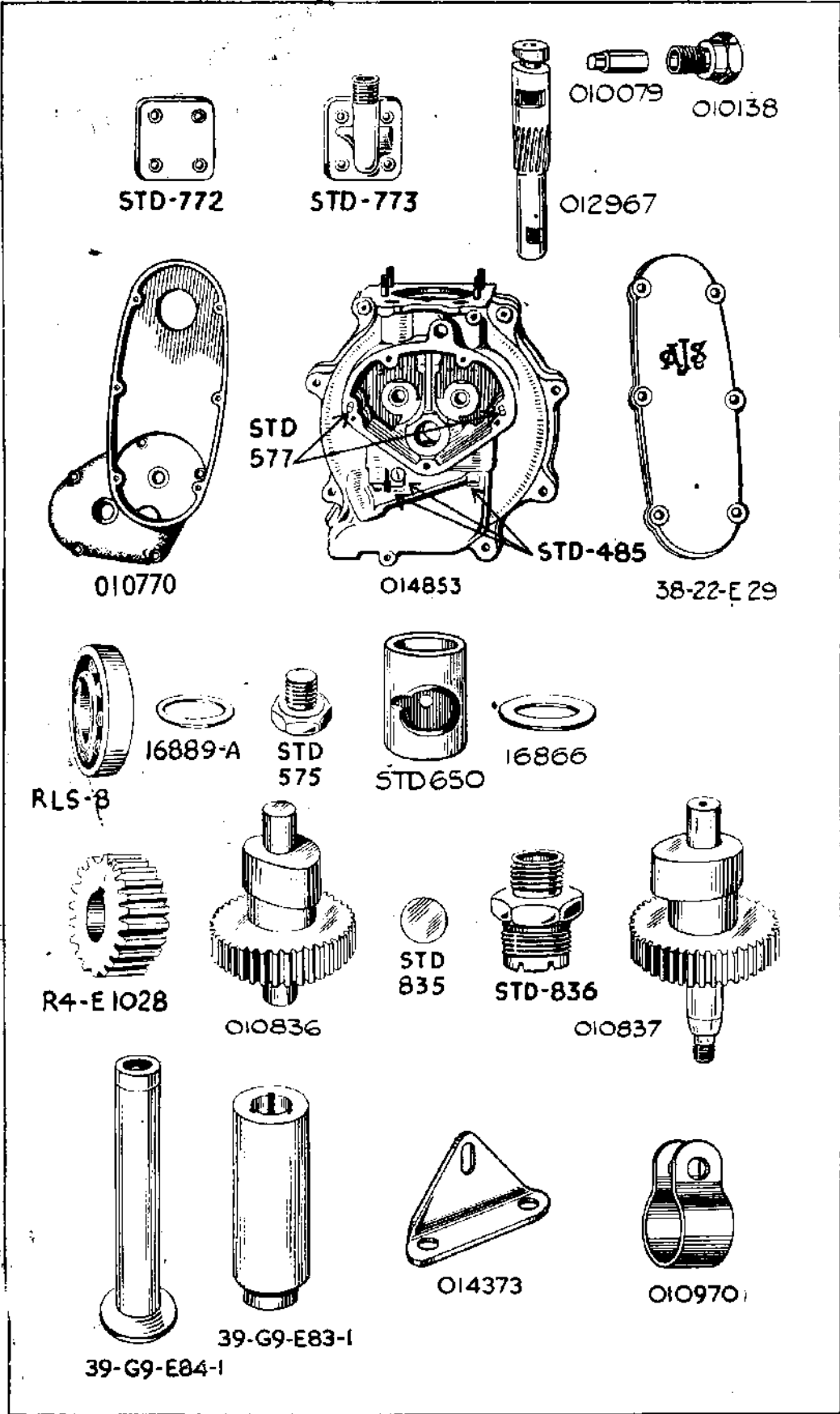

This scan is explicit for non-commercial use and is not intended for financial or material gain by anyone

PART NUMBER	NEW		DESCRIPTION.	QTY.	USED ON	PRICE EACH		
	OLD					£	s.	d.

CRANKCASE BEARINGS.

STD-650	Bush, timing side flywheel axle.....	1	...	All	...	4	11
012233	Peg, securing bush.....	1	...	All	...		1
RLS-8	Ball bearing, for driving side axle.....	2	...	All	...	14	4
16866	Washer, spacing, between ball bearings (SKEFKO) (4)	1	...	All	...		4
014830	Washer, spacing, between ball bearings (HOFFMAN) (4)	1	...	All	...		4
16889-A	Collar, spacing, between ball bearings.....	1	...	All	...		3
STD-651	Bush, for exhaust cam, in crankcase.....	1	...	All	...	2	10
STD-652	Bush, for exhaust cam, in timing cover.....	1	...	All	...	2	10
STD-651	Bush, for inlet cam, in crankcase.....	1	...	All	...	2	10
STD-651	Bush, for inlet cam, in timing cover.....	1	...	All	...	2	10

Dimensions of RLS-8 bearing 1 in. by 2½ in. by ¾ in.

NOTE 4. The standard make of ball bearing used on the driving side flywheel axle is "SKEFKO." Those bearings are in short supply and it has been necessary to use ball bearings of American "HOFFMAN" make.

Spacing washer 16866 is used with "SKEFKO" bearings and spacing washer 014830 is used with "HOFFMAN" bearings.

If one "SKEFKO" and one "HOFFMAN" bearing are fitted, as may occur as the result of fitting an "odd" replacement bearing, then the "HOFFMAN" bearing must have a spacing washer 014830 against it and the spacing collar 16889-A should be fitted so that it abuts against the "SKEFKO" bearing.

CRANKCASE BOLTS.

010824	Bolt, front, top position, 6 3/8 in. by 5/16 in.	1	...	All	...	8	6
STD-278	Bolt, front, centre position, 4 3/8 in. by 5/16 in.	1	...	All	...	6	6
STD-277	Bolt, front, bottom position, 4 3/8 in. by 5/16 in.	1	...	All	...	6	6
STD-261	Bolt, bottom, rear position, 4 3/8 in. by 5/16 in.	1	...	All	...	6	6

For the "Bolt, bottom, front position" (which also unites the front and rear frames) see "FRAME," pages 23 and 46.

STD-278	Bolt, rear, top position, 4 3/8 in. by 5/16 in.	1	...	All	...	6	6
---------	-----	-----	---	---	-----	-----	-----	---	---

For the "Bolt, rear, centre position" see "STD-316, bolt, fixing centre of chaincase," on page 29, "FRONT CHAINCASE."

014147	Bolt, rear, bottom position, 4 3/8 in. by 5/16 in.	1	...	All	...	6	6
STD-11	Washer, plain, for 5/16 in. bolts	8	...	All	...		1
STD-5	Nut, for bottom, rear bolt (½ in.)	2	...	All	...		3
STD-4	Nut, for all 5/16 bolts	9	...	All	...		3

OIL PUMP.

012967	Plunger, oil pump.....	1	...	All	...	11	5
010138	Screw, guide, oil pump plunger.....	1	...	All	...		9
010079	Pin, guide screw, oil pump plunger.....	1	...	All	...		8
STD-773	Cap, front end, oil pump.....	1	...	All	...	2	4
STD-772	Cap, rear end, oil pump.....	1	...	All	...		10
STD-582	Washer, paper, pump end cap.....	2	...	All	...		1
STD-15	Screw, fixing front end cap, oil pump.....	4	...	All	...		1
STD-591	Bolt, fixing rear end cap, oil pump.....	4	...	All	...		3

RELEASE VALVE.

STD-836	Body, release valve.....	1	...	All	...	1	7
STD-835	Diaphragm, for release valve.....	1	...	All	...		3

TIMING GEAR.

010836	Camshaft, inlet.....	1	...	All	...	1	2	0
010837	Camshaft, exhaust.....	1	...	All	...	19	3	
R4-E1028	Pinion, timing, on flywheel axle.....	1	...	All	...	7	7	
STD-570	Key, for timing pinion.....	1	...	All	...		4	
STD-221	Nut, retaining timing pinion to axle.....	1	...	All	...		4	

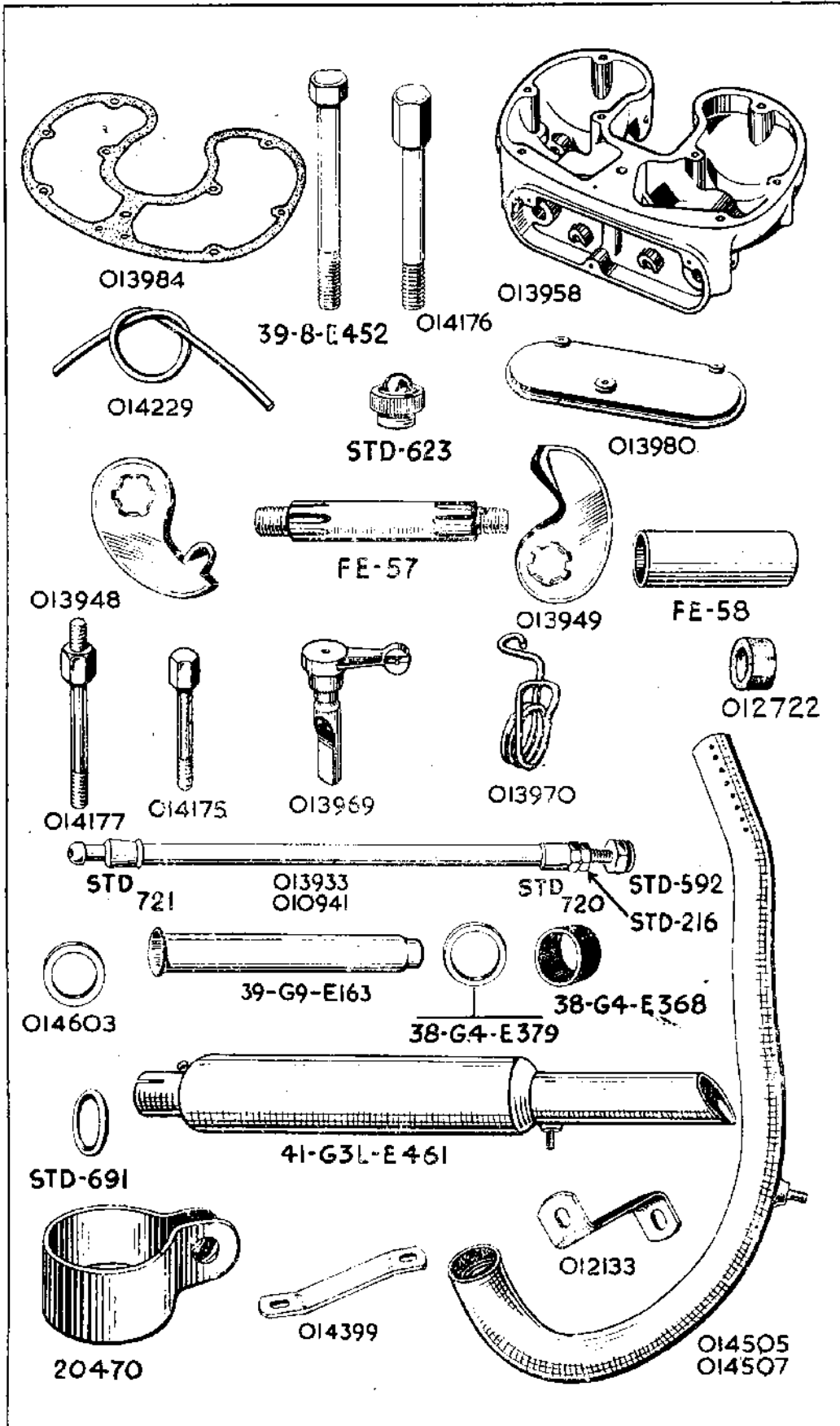

This scan is explicit for non-commercial use and is not intended for financial or material gain by anyone

PART NUMBER.		DESCRIPTION.	QTY.	USED ON.	PRICE EACH
OLD	NEW				

TAPPETS.

39-G9-E84-1	010950	Tappet, bare.....	2	All	5 4
39-G9-E83-1	010944	Guide, for tappet.....	2	All	4 1

PUSH RODS.

014831	...	Rod, long, push, complete (5).....	2	350	6 11
014832	...	Rod, long, push, complete (5).....	2	500	6 11
013933	...	Rod, long, push, bare.....	2	350	1 11
39-G9-E113	010941	Rod, long, push, bare.....	2	500	1 11
STD-721	...	End, ball, bottom of long push rod.....	2	All	1 7
STD-720	...	End, sleeve, top of long push rod.....	2	All	1 2
STD-592	...	Screw, adjusting, top of long push rod.....	2	All	1 7
STD-216	...	Nut, lock, push rod adjusting screw.....	2	All	6

NOTE 5.—"ROD, LONG, PUSH, COMPLETE" comprises—one long push rod, one bottom ball end, one top end sleeve, one adjusting screw and one lock nut.

PUSH RODS COVER TUBES.

39-G9-E163	010952	Tube, cover, for long push rod.....	2	All	4 1
38-G4-E368	...	Gasket, for top of cover tube.....	2	All	6
38-G4-E379	...	Washer, plain metal, top of gasket $\frac{3}{4}$ in. thick.....	2	350	4
014603	...	Washer, plain metal, top of gasket $\frac{1}{2}$ in. thick.....	2	500	4
STD-691	...	Gland, rubber, bottom of cover tube.....	2	All	4

ROCKER BOX.

014159	...	Box, rocker, assembled (6).....	1	All	5 0 5
014364	...	Box, rocker, with bushes (7).....	1	All	2 3 2
013958	...	Box, rocker, bare.....	1	All	1 13 0
39-8-E452	...	Bolt, fixing rocker box, short head, centre.....	1	All	1 1
014176	...	Bolt, fixing rocker box, long.....	4	350	11
014176	...	Bolt, fixing rocker box, long.....	2	500	11
014175	...	Bolt, fixing rocker box, short.....	4	All	6
014177	...	Bolt, fixing rocker box, with extension.....	2	500	1 4
STD-11	...	Washer, plain, rocker box fixing bolt.....	9	All	1
013980	...	Cover, side, for rocker box.....	1	All	5 9
014229	...	Fillet, rubber, rocker box side cover.....	1	All	4
STD-251	...	Stud, fixing rocker box side cover.....	3	All	3
STD-623	...	Nut, for rocker box side cover stud.....	3	All	7
STD-205	...	Washer, fibre, for rocker box side cover nut.....	3	All	1
013984	...	Gasket, for rocker box.....	1	All	10
38-G4-E204	...	Bush, for rocker box.....	4	All	2 5

NOTE 6.—Includes all parts listed in this paragraph (except fixing bolts) and all those listed in the following two paragraphs (Overhead Rockers and Exhaust Valve Lifter).

NOTE 7.—This is a "bare" rocker box to which is fitted—four 38-G4-E204 rocker box bushes and two 012722 felt rings.

OVERHEAD ROCKERS.

F-E57	...	Axle, rocker.....	2	All	5 9
F-E58	...	Sleeve, for rocker axle.....	2	All	4 11
013949	...	Arm, rocker, valve end, inlet and exhaust.....	2	All	4 1
013948	...	Arm, rocker, tappet end, inlet and exhaust.....	2	All	3 8
STD-10	...	Washer, plain, for rocker axle.....	4	All	1
STD-3	...	Nut, for rocker axle.....	4	All	3
012722	...	Ring, felt, for rocker axle sleeve.....	2	All	3

EXHAUST VALVE LIFTER.

013969	...	Lever, exhaust lifter.....	1	All	9 3
014523	...	Ring, sealing, for valve lifter lever.....	1	All	4
013970	...	Spring, for valve lifter lever.....	1	All	4
STD-451	...	Screw, anchor, valve lifter spring.....	1	All	3
STD-39	...	Washer, plain, valve lifter spring screw.....	1	All	1

PART NUMBER.	DESCRIPTION.	QTY.	USED ON.	PRICE EACH	
				£	s. d.

ROCKER BOX STAY.

OLD	NEW				
014373	...	Stay, for rocker box.....	1	500	1 3
STD-4	...	Nut, fixing stay to rocker box bolt extension.....	2	500	3
STD-11	...	Washer, plain, rocker box bolt extension.....	2	500	1
010970	...	Clip, for rocker box stay.....	1	500	10
STD-363	...	Bolt, for rocker box stay clip.....	1	500	4
STD-11	...	Washer, plain, rocker box stay clip bolt.....	1	500	1
STD-4	...	Nut, rocker, box stay clip bolt.....	1	500	3

GASKETS.

We supply gaskets, either as separate spares, or in complete sets.

Single gaskets are listed in the groups to which they belong.

Gaskets in complete sets are listed below.

49-EQ-1	...	Complete gasket set for 350 c.c. models.....	1	350	7 10
49-EQ-2	...	Complete gasket set for 500 c.c. models.....	1	500	8 1
49-EQ-3	...	Decarbonising gasket set 350 c.c. models.....	1	350	4 8
49-EQ-4	...	Decarbonising gasket set 500 c.c. models.....	1	500	4 11

Each complete gasket set contains:—

- | | |
|--|---|
| * 1 Cylinder base washer. (2 in 500 c.c. set.) | 2 Washers, fork oil drain screws. |
| * 1 Cylinder head gasket. | 1 Gasket, carburetter. |
| 1 Timing gear cover washer. | 1 Gasket, carburetter packing piece. |
| * 2 Glands, bottom of cover tubes. | * 1 Gasket, rocker box. |
| * 2 Gaskets, top of cover tubes. | 2 Washers, oil pump end caps. |
| * 1 Fillet, rocker box side cover. | * 3 Washers, rocker box side cover studs. |
| 2 Washers, petrol feed taps. | 1 Washer, oil tank drain plug. |
| 1 Washer, oil filter compartment cap. | 1 Chaincase rubber band. |
| 1 Washer, chaincase inspection cap. | |

NOTE—Decarbonising gasket set contains only those items marked *

See page 45 for Gasket Sets suitable for the Competition Models

EXHAUST PIPE AND SILENCER SECTION.

PART NUMBER.	DESCRIPTION.	QTY.	USED ON.	PRICE EACH	
				£	s. d.

EXHAUST PIPE.

014505	...	Pipe, exhaust, bare.....	1	350	1 13 10
014507	...	Pipe, exhaust, bare.....	1	500	1 13 10
20493-1	...	Baffle, for exhaust pipe.....	1	500	4 4
012133	...	Stay, for exhaust pipe.....	1	All	2 5
STD-4	...	Nut, fixing, exhaust pipe to stay.....	1	All	3
STD-174	...	Washer, plain, exhaust pipe fixing nut.....	1	All	1
STD-192	...	Washer, spring, exhaust pipe fixing nut.....	1	All	1

SILENCER.

41-G3L-E461	...	Silencer, bare.....	1	350	1 12 2
011119	...	Silencer, bare.....	1	500	1 12 2
20470	...	Clip, clamping silencer to pipe.....	1	350	1 7
STD-745	...	Clip, clamping silencer to pipe.....	1	500	1 7
STD-363	...	Bolt, for silencer clip.....	1	All	4
STD-174	...	Washer, plain, for silencer clip bolt.....	1	All	1
STD-192	...	Washer, spring, for silencer clip bolt.....	1	All	1
STD-4	...	Nut, for silencer clip bolt.....	1	All	3
014399	...	Stay, for silencer.....	1	All	1 9
STD-4	...	Nut, fixing silencer to stay.....	1	All	3
STD-174	...	Washer, plain, for silencer fixing nut.....	1	All	1
STD-192	...	Washer, spring, for silencer fixing nut.....	1	All	1
STD-363	...	Bolt, fixing silencer stay to fork end.....	1	All	4
STD-174	...	Washer, plain, for fork end bolt.....	2	All	1
STD-192	...	Washer, spring, for fork end bolt.....	1	All	1
STD-4	...	Nut, for fork end bolt.....	1	All	3

CARBURETTER SECTION.

PART NUMBER.		DESCRIPTION.	QTY.	USED ON.	PRICE EACH		
OLD.	NEW				£	s.	d.
CARBURETTER.							
014185		Carburetter, complete (less controls) Type 76AE-1AK	1	350	3	0	0
011068		Carburetter, complete (less controls) Type 89B-1AK	1	500	3	10	6
41-G3L-E167		Spacer, for carburetter, $\frac{3}{8}$ in. thick	1	350		2	5
36-G8C-E167	011217	Spacer, for carburetter, $\frac{1}{8}$ in. thick	1	500		2	5
STD-581		Gasket, for carburetter	1	All			3
STD-581		Gasket, for carburetter spacer	1	All			3
FLOAT CHAMBER.							
64-302		Chamber, float, bare	1	350	14	0	
64-302		Chamber, float, bare	1	500	14	0	
13-153		Screw, plug, passage in float chamber	1	All			3
14-039		Washer, fibre, passage plug screw	1	All			1
4-043		Bolt, holding float chamber	1	350	3	0	
29-077		Bolt, holding float chamber	1	500	3	0	
4-053		Washer, fibre, chamber holding bolt	2	All			2
14-208		Top, (or cover), for float chamber	1	All	3	9	
14-021		Screw, locking float chamber top	1	All			4
14-015		Float, bare	1	All	3	9	
14-024		Needle, for float	1	All	1	6	
14-178		Nut, lock, float needle seat	1	All			4
14-175		Washer, fibre, float needle seat	1	All			2
14-209		Tickler	1	All			10
14-210		Stop, for tickler	1	All			3
14-032		Spring, for tickler	1	All			2
14-289		Cotter, for tickler	1	All			1
14-014		Spring, bow, for float	1	All			4
MIXING BODY.							
76-014		Body, mixing, bare	1	350	14	0	
89-403		Body, mixing, bare	1	500	16	0	
6-062		Nut, union, mixing body base	1	350	2	3	
29-072		Nut, union, mixing body base	1	500	3	0	
6-040		Washer, fibre, body union nut	1	350			2
29-050		Washer, fibre, body union nut	1	500			2
6-032-B		Top, for mixing chamber	1	350	2	6	
29-042		Top, for mixing chamber	1	500	3	3	
6-031		Ring, fixing top to mixing body	1	350	2	6	
29-041		Ring, fixing top to mixing body	1	500	3	0	
4-235		Clip, locking top fixing ring	1	350			9
29-201		Clip, locking top fixing ring	1	500			9
4-241		Screw, securing locking clip to body top	1	All			2
4-035		Adjuster, for control cable, throttle or air	2	All			6
206-038-R		Intake, air	1	350	3	0	
29-048		Intake, air	1	500	3	6	
JETS							
6-058		Choke, or jet barrel	1	350	7	6	
29-068		Choke, or jet barrel	1	500	10	0	
4-061		Needle jet	1	350	2	6	
29-076		Needle jet	1	500	2	6	
4-042-150		Jet, main, size 150 (no air cleaner fitted)	1	350			8
4-042-180		Jet, main, size 180 (no air cleaner fitted)	1	500			0
6-065		Needle, taper, for needle jet	1	350	2	3	
29-075		Needle, taper, for needle jet	1	500	2	0	
4-230		Clip, for jet taper needle	1	All			6
4-060		Pin, split, locating taper needle clip	1	All			1
13-129		Screw, for pilot jet air adjustment	1	All			9
4-206		Nut, lock, for pilot jet air screw	1	All			2
<i>We can also supply the following alternative jets.</i>							
4-042-130		Jet, main, size 130	1	All			
4-042-140		Jet, main, size 140	1	All			
4-042-160		Jet, main, size 160	1	All			
4-042-170		Jet, main, size 170	1	All			

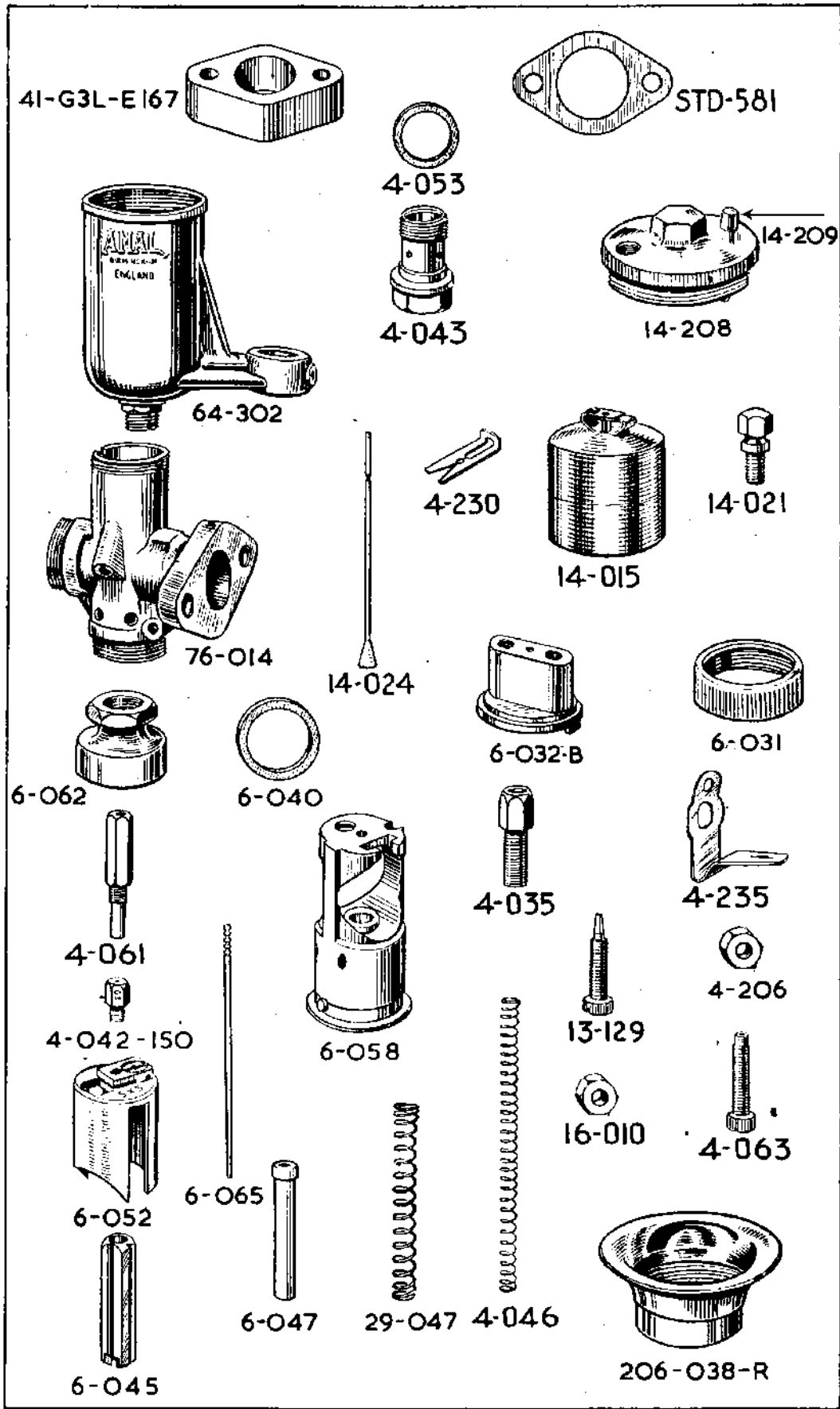

This scan is explicit for non-commercial use and is not intended for financial or material gain by anyone

PART NUMBER.	DESCRIPTION.	QTY.	USED ON.	PRICE EACH	
				£	s. d.

VALVES (CARBURETTER).

OLD	NEW	DESCRIPTION.	QTY.	USED ON.	PRICE EACH
6-052	...	Valve, throttle, size 6 by 4.....	1	350	6 0
29-062	...	Valve, throttle, size 29 by 4.....	1	500	6 6
29-047	...	Spring, for throttle valve.....	1	350	4
4-263	...	Spring, for throttle valve.....	1	500	4
4-063	...	Screw, stop, for throttle valve.....	1	All	9
4-206	...	Nut, lock, for throttle stop screw.....	1	All	2
6-045	...	Valve, air.....	1	350	3 9
29-055	...	Valve, air.....	1	500	4 0
6-047	...	Guide, tubular, for air valve spring.....	1	350	1 0
29-057	...	Guide, tubular, for air valve spring.....	1	500	1 3
4-046	...	Spring, for air valve.....	1	All	4

AIR CLEANER (This is optional extra Equipment).

014583	...	Cleaner, air.....	1	All	16 0
014591	...	Adaptor, for air cleaner.....	1	350	1 6
014592	...	Adaptor, for air cleaner.....	1	500	1 6

When an AIR CLEANER is fitted it is essential to:—

- (a) Use an adaptor in order to fit the cleaner to carburetter intake. (014583 does not include the adaptor.)
- (b) Fit a smaller jet, viz : —
 for 350 c.c. use Jet 130 (Part No. 4-042-130.)
 for 500 c.c. use Jet 160 (Part No. 4-042-160.)
- (c) Discard the standard petrol tank fixing bolt in the rear, right position and one metal washer and the thin rubber pad and fit, in lieu, a special screw and spigot washer as detailed in "PETROL TANK" on page 35.

TRANSMISSION SECTION.

PART NUMBER.	DESCRIPTION.	QTY.	USED ON.	PRICE EACH	
				£	s. d.

ENGINE SPROCKET.

014018	...	Sprocket, engine, bare, 18 teeth.....	1	350	1 1 6
014021	...	Sprocket, engine, bare, 21 teeth.....	1	500	1 2 10
35-G3-E124	...	Spacer, collar, for engine sprocket.....	1	All	1 2
STD-830	...	Cam, engine, shock absorber.....	1	All	8 3
STD-702	...	Spring, engine shock absorber.....	1	350	2 0
STD-703	...	Spring, engine shock absorber.....	1	500	2 5
STD-831	...	Cap, engine shock absorber spring.....	1	All	1 1
STD-610	...	Nut, lock, engine shock absorber.....	1	All	10

We can also supply the following alternative engine sprockets.

014015	...	Sprocket, engine, bare, 15 teeth.....	1	All	0
014016	...	Sprocket, engine, bare, 16 teeth.....	1	All	0
014017	...	Sprocket, engine, bare, 17 teeth.....	1	All	1
014019	...	Sprocket, engine, bare, 19 teeth.....	1	All	1
014020	...	Sprocket, engine, bare, 20 teeth.....	1	All	1

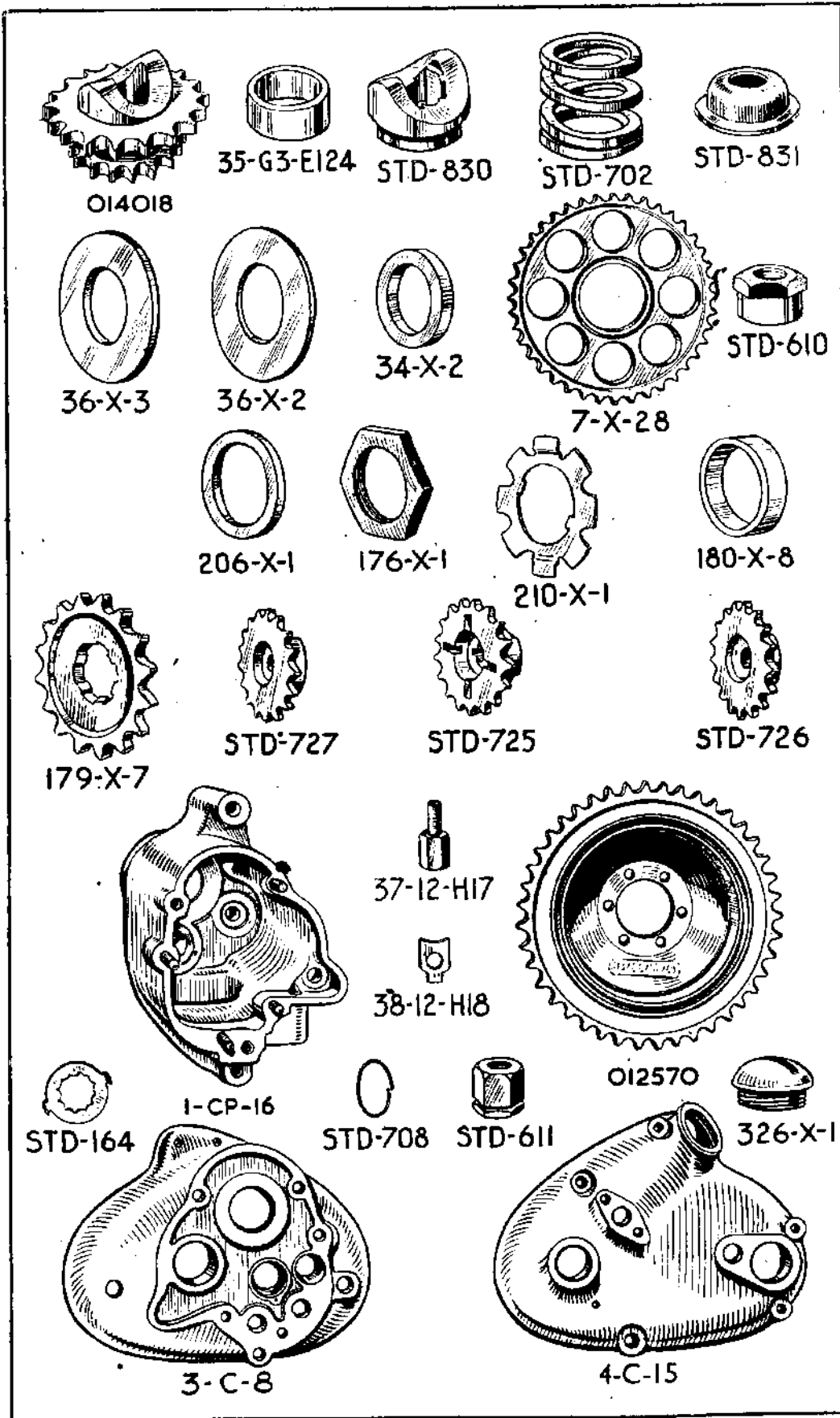

This scan is explicit for non-commercial use and is not intended for financial or material gain by anyone

PART NUMBER.	DESCRIPTION.	QTY.	USED ON.	PRICE EACH	
				OLD	NEW

CLUTCH SPROCKET.

7-X-28	Chainwheel, bare, 40 teeth (8)	1	All	10	0
34-X-2	Race, roller, clutch sprocket bearing	1	All	3	0
35-X	Rollers, clutch sprocket bearing, per set	24	All	5	3
36-X-2	Washer, thin, clutch sprocket bearing	1	All	1	1
36-X-3	Washer, thick, clutch sprocket bearing	1	All	1	1

NOTE 8.—For chainwheel, assembled with clutch case, see CLUTCH, Page 22.

GEAR BOX SMALL SPROCKET.

179-X-7	Sprocket, gear box, 16 teeth	1	All	2	6
180-X-8	Collar, spacing, gear box sprocket, $\frac{3}{8}$ in. thick	1	All	1	6
176-X-1	Nut, fixing gear box sprocket to main gear	1	All	2	7
206-X-1	Collar, spacing, under gear box sprocket, $\frac{3}{8}$ in. thick	1	All		6
210-X-1	Washer, lock, gear box sprocket nut	1	All		6

REAR WHEEL SPROCKET.

012570	Sprocket and brake drum, rear wheel, 42 teeth	1	All	15	0
37-12-H17	Bolt, retaining sprocket to rear hub	6	All		4
38-12-H18	Washer, lock, sprocket retaining nut	6	All		1
STD-11	Washer, plain, sprocket retaining bolt	6	All		1
STD-74	Nut, rear wheel sprocket retaining bolt	6	All		3

MAGNETO DRIVING SPROCKETS.

STD-727	Sprocket, magneto, on engine camshaft	1	All	6	11
STD-11	Washer, plain, for camshaft sprocket	1	All		1
STD-4	Nut, retaining, for camshaft sprocket	1	All		3
STD-726	Sprocket, magneto, on armature shaft	1	All	6	11
140074	Washer, plain, armature sprocket	1	All		1
171284	Nut, retaining, armature shaft sprocket	1	All		3

DYNAMO SPROCKET.

STD-725	Sprocket, on dynamo shaft	1	All	5	9
STD-572	Key, for dynamo sprocket	1	All		3
STD-10	Washer, plain, dynamo sprocket nut	1	All		1
STD-164	Washer, lock, dynamo sprocket nut	1	All		3
STD-708	Ring, lock, dynamo sprocket nut	1	All		1
STD-611	Nut, retaining dynamo sprocket	1	All		10

CHAINS.

110046-66	Chain, front, 66 Links, $\frac{1}{2}$ in. by 305 in. (9)	1	350	14	10
110046-67	Chain, front, 67 Links, $\frac{1}{2}$ in. by 305 in. (9)	1	500	15	1
110056-94	Chain, rear, 94 Links, $\frac{3}{8}$ in. by 380 in. (9)	1	All	11	4
110038-46	Chain, magneto, 46 Links, $\frac{3}{8}$ in. by 225 in. (10)	1	All	6	1
110038-49	Chain, dynamo, 49 Links, $\frac{3}{8}$ in. by 225 in. (10)	1	All	6	6
110046-26	Link, connecting, for $\frac{1}{2}$ in. chains	-	All		5
110056-26	Link, connecting, for $\frac{3}{8}$ in. chains	-	All		7 $\frac{1}{2}$
110046-30	Link, cranked, for $\frac{1}{2}$ in. chains	-	All		9
110056-30	Link, cranked, for $\frac{3}{8}$ in. chains	-	All		1
110046-27	Clip, spring, for $\frac{1}{2}$ in. connecting links	-	All		1
110056-27	Clip, spring, for $\frac{3}{8}$ in. connecting links	-	All		1 $\frac{1}{2}$

NOTE 9.—The prices of front and rear chains include spring connecting links and these are also included in the number of links per chain. We do not sell odd lengths of chains.

NOTE 10.—Magneto and Dynamo chains are endless. We do not sell connecting and cranked links for same.

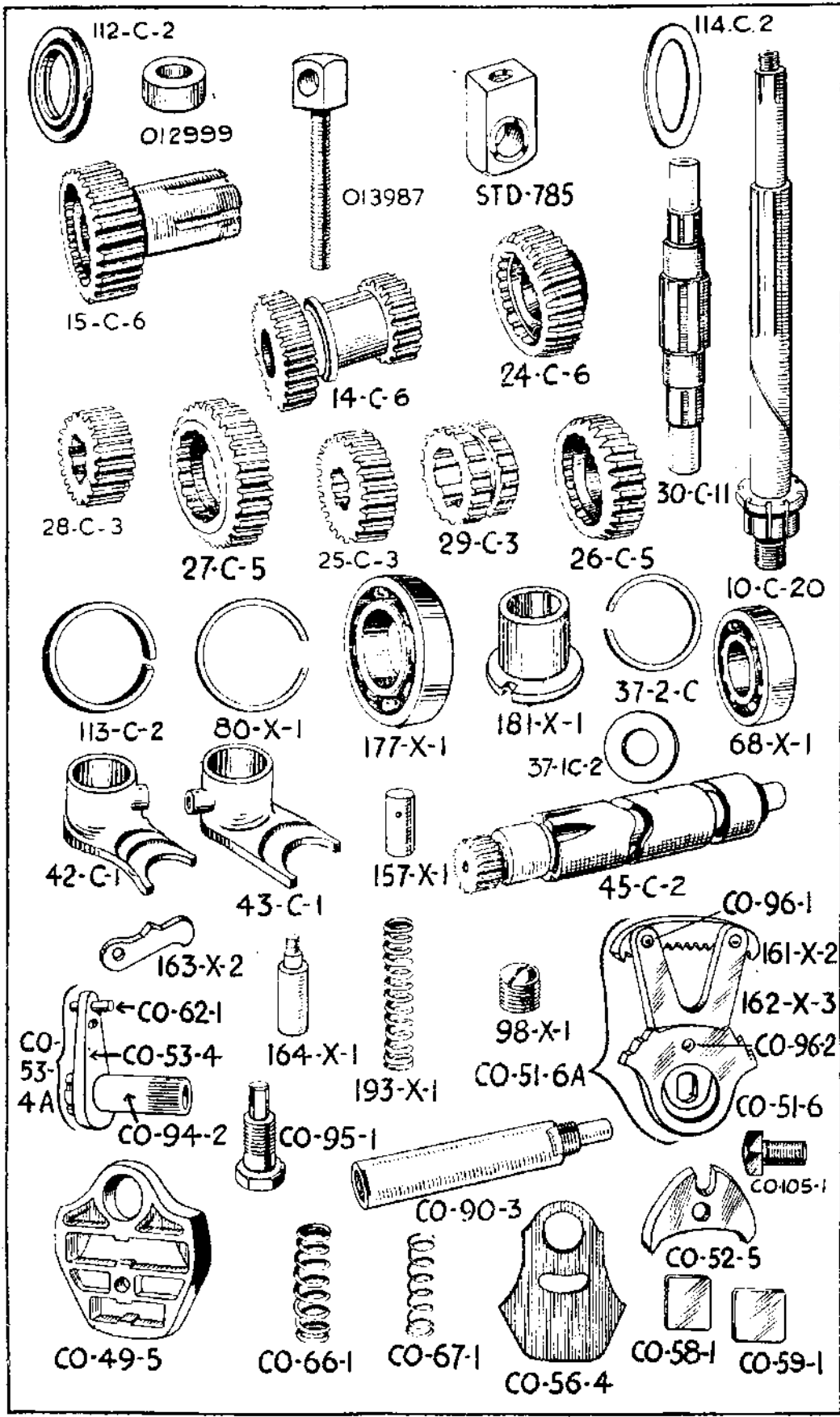

This scan is explicit for non-commercial use and is not intended for financial or material gain by anyone

PART NUMBER.	DESCRIPTION.	QTY.	USED ON.	PRICE		
				OLD	NEW	EACH £ s. d.

GEAR BOX SHELL.

1-CP-16	Shell gear box, bare	1	...	All	2	2	0
60-X-6	Stud, gear box shell, 1 $\frac{1}{8}$ in. by $\frac{1}{8}$ in.	2	...	All			9
60-X-9	Stud, gear box shell, 3 $\frac{1}{8}$ in. by $\frac{1}{8}$ in.	2	...	All			9
60-X-1	Stud, gear box shell, 1 in. by $\frac{1}{4}$ in.	2	...	All			9
152-X-1	Nut, for $\frac{3}{8}$ in. gear box shell stud	4	...	All			4
63-X-1	Nut, for $\frac{1}{2}$ in. gear box shell stud	2	...	All			3
348-X-1	Plug, drain, for gear box shell	1	...	All			9
356-X-1	Washer, drain plug	1	...	All			1
3-C-8	Case, kick-starter	1	...	All	1	2	6
2-1C-2	Washer, paper, for kick-starter case	1	...	All			1
286-X-1	Stud, kick-starter case, 2 $\frac{1}{2}$ in. by $\frac{1}{4}$ in.	3	...	All			9
63-X-1	Nut, for $\frac{1}{2}$ in. kick-starter case stud	3	...	All			3
4-C-15	Cover, for kick-starter case	1	...	All	1	2	6
4-1C-2	Washer, paper, for kick-starter case cover	1	...	All			1
326-X-1	Cap, filler, for kick-starter case cover	1	...	All	3		0
12-5-2	Cap, in K/S case, for sector spindle bore	1	...	All			3
291-X	Cap, in shell, covering bore of camshaft	1	...	All			3

GEAR BOX FIXING BOLTS.

39-G9-G59	010957	...	Bolt, gear box top fixing, 5 $\frac{1}{8}$ in. by $\frac{1}{8}$ in.	1	...	All	2		0
STD-313	Bolt, gear box bottom fixing, 4 $\frac{1}{8}$ in. by $\frac{1}{8}$ in.	1	...	All			10
012999	Spacer, on top bolt, outside, right	1	...	All			4
39-G9-G61	011086	...	Spacer, on top bolt, inside, left and right	2	...	All			4
39-G9-G61	011086	...	Spacer, on bottom bolt, inside, left and right	2	...	All			4
STD-2	Nut, gear box top fixing bolt	2	...	All			4
STD-2	Nut, gear box bottom fixing bolt	2	...	All			4
STD-9	Washer, plain, top fixing bolt, left side	1	...	All			1
013987	Eye-bolt, front chain adjustment	1	...	All	1		9
STD-215	Nut, front, chain adjustment eye-bolt	2	...	All			4
STD-785	Crosshead, front chain adjustment eye-bolt	1	...	All	1		0
STD-361	Bolt, fixing crosshead to engine plate	1	...	All			3
STD-11	Washer, plain, crosshead fixing bolt	1	...	All			1

SHAFTS AND GEARS.

10-C-20	Mainshaft, gear box, 10 $\frac{1}{2}$ in. overall length	1	...	All	1	18	3
15-C-6	Gear, driving, mainshaft, with bushes, 30 teeth	1	...	All	2	8	0
187-X-3	Bush, only, mainshaft driving gear	2	...	All			3
14-C-6	Gear, sliding, mainshaft, 18/23 teeth	1	...	All	2	5	0
24-C-6	Gear, third, on mainshaft, 27 teeth, with bush	1	...	All	1	1	0
357-X-1	Bush, for mainshaft third gear	1	...	All			2
30-C-11	Layshaft, gear box, with bushes	1	...	All	1	13	0
28-C-3	Gear, small, on layshaft, 20 teeth	1	...	All			15
27-C-5	Gear, first, on layshaft, 32 teeth	1	...	All			18
26-C-5	Gear, second, on layshaft, 27 teeth	1	...	All			18
25-C-3	Gear, third, on layshaft, 23 teeth	1	...	All			15
29-C-3	Clutch, sliding, on layshaft	1	...	All			15

GEAR BOX BEARINGS.

177-X-1	Ball bearing, driving gear (11)	1	...	All	1	2	6
112-C-2	Oil seal, main driving gear bearing, rubber	1	...	All			3
80-X-1	Ring, split, retaining bearing in shell	1	...	All			9
114-C-2	Washer, outer, driving gear bearing (12)	2	...	All			4
113-C-2	Ring, split, retaining bearing outer washer	1	...	All			6
68-X-1	Ball bearing, mainshaft, K-S end (13)	1	...	All	18		9
37-1-C-2	Washer, mainshaft ball bearing K-S end (14)	1	...	All			9
37-2-C	Ring, split, retaining mainshaft ball bearing K-S end	1	...	All			6
181-X-1	Bush, for layshaft	2	...	All			6
182-X-1	Cap, covering layshaft bush in gear box shell	1	...	All			3

NOTE 11.—Dimensions 1 $\frac{3}{8}$ in. by 62 mm. by 16 mm. (177-X-1).

NOTE 12.—Dimensions 1 $\frac{13}{16}$ in. by 2 $\frac{1}{16}$ in. (114-C-2).

NOTE 13.—Dimensions 12 mm. by 40 mm. by 17 mm. (68-X-1).

NOTE 14.—Dimensions 1 $\frac{1}{4}$ in. by 1 $\frac{1}{8}$ in. (37-1-C-2).

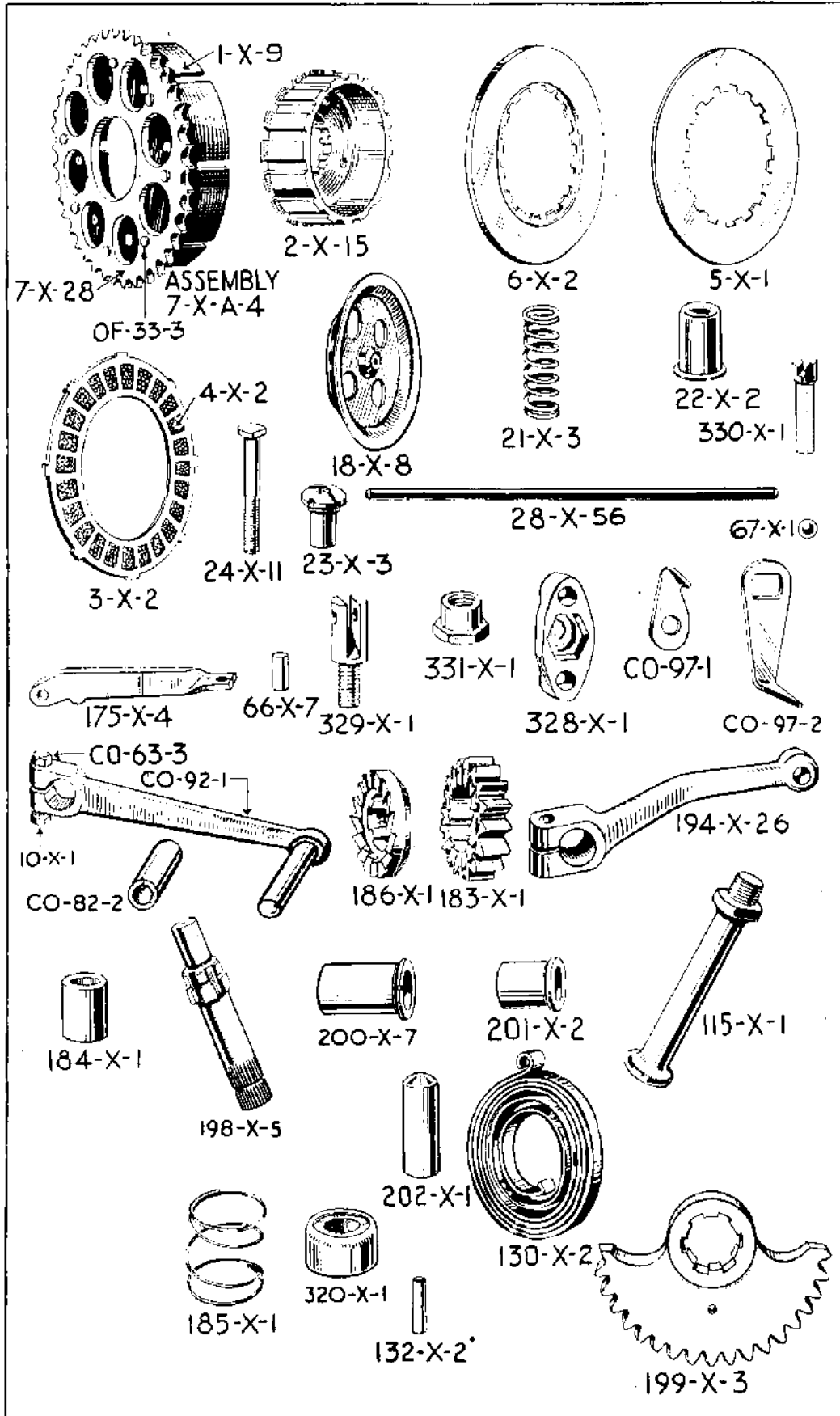

This scan is explicit for non-commercial use and is not intended for financial or material gain by anyone

PART NUMBER.	DESCRIPTION.	QTY.	USED ON.	PRICE EACH	
				OLD	NEW

GEAR OPERATING PARTS.

42-C-1	Fork, operating mainshaft sliding gear.....	1	All	12	0
43-C-1	Fork, operating layshaft sliding clutch.....	1	All	12	0
157-X-1	Peg, operating layshaft sliding clutch.....	2	All		9
158-X-1	Pin, split, operating fork peg.....	2	All		1
45-C-2	Camshaft, bare, for gear box.....	1	All	17	6
192-X-1	Rollers for camshaft (per set of).....	12	All	3	0
159-X-1	Bush, for camshaft, in gear box shell.....	1	All	3	0
163-X-2	Pawl, engages in gear box camshaft.....	1	All	3	0
164-X-1	Pin, bearing, for camshaft pawl.....	1	All	1	10
95-X-1	Nut, for camshaft pawl bearing pin.....	1	All		4
193-X-1	Spring, for camshaft pawl.....	1	All	1	1
98-X-1	Plug, screwed, retaining camshaft pawl spring.....	1	All	1	6
162-X-3	Quadrant, gear selection.....	1	All	5	3
161-X-2	Sector, gear selection, engages camshaft.....	1	All	6	0
CO-51-6	Ratchet, gear selection.....	1	All	5	3
CO-51-6-A	Quadrant, sector and ratchet, assembled.....	1	All	16	4
CO-96-1	Rivet, fixing camshaft sector to quadrant.....	2	All		1
CO-96-2	Rivet, fixing camshaft ratchet to quadrant.....	1	All		1
CO-90-3	Spindle, for gear selection quadrant.....	1	All	5	3
287-X-1	Nut (inside), gear selection quadrant spindle.....	1	All		3
CO-91-1	Bush, in kick-starter case, for control spindle.....	1	All	1	6
160-X-2	Bush, in kick-starter case, for camshaft.....	1	All	3	0
CO-53-4	Quadrant, for foot gear control.....	1	All	4	6
CO-94-2	Sleeve, for foot gear control quadrant.....	1	All	11	3
CO-62-1	Peg, for gear indexing pawl.....	2	All		4
CO-53-4-A	Quadrant, assembled with sleeve and peg.....	1	All	16	2
CO-54-14	Bush, for foot control quadrant sleeve.....	1	All	7	6
CO-95-1	Bolt, fixing quadrant sleeve bush in K-S cover.....	1	All	1	10
CO-52-5	Pawl, indexing, for foot gear control.....	1	All	2	3
CO-49-5	Box, spring, for foot gear control.....	1	All	7	6
CO-56-4	Plate, cover, for foot gear control spring box.....	1	All	1	6
CO-66-1	Spring, main, for control box (large spring).....	2	All		9
CO-67-1	Spring, pawl, for control box (small spring).....	2	All		9
CO-59-1	Plate, for control box main spring.....	2	All		3
CO-58-1	Plate, for control box pawl spring.....	2	All		3

GEAR CONTROL PARTS.

CO-97-1	Indicator, gear, fixed.....	1	All		4
CO-97-2	Indicator, gear, moving.....	1	All		9
CO-105-1	Bolt, retaining moving gear indicator.....	1	All		3
CO-92-1	Lever, foot, gear control.....	1	All	11	3
CO-63-3	Bolt, clamping gear foot lever to sleeve.....	1	All	1	1
10-X-1	Nut, for gear foot lever clamping bolt.....	1	All		3
OS-52-1	Washer, foot lever clamping bolt.....	1	All		1
CO-82-2	Pad rubber, foot control lever.....	1	All	1	3
CO-38-2	Pin fixing control lever rubber pad.....	1	All		1
27-7-2	Washer, felt, inserted in control spindle bush (15).....	1	All		4
27-8-3	Washer, felt, fits in recess in foot change lever (16).....	1	All		4

NOTE 15— $\frac{17}{32}$ in. inside diameter.
 $\frac{9}{16}$ in. outside diameter.
 $\frac{1}{8}$ in. thick.

NOTE 16— $\frac{13}{16}$ in. inside diameter.
 1 in. outside diameter.
 $\frac{1}{8}$ in. thick.

PART NUMBER.		DESCRIPTION.	QTY.	USED ON.	PRICE EACH	
OLD	NEW				£	s. d.
CLUTCH.						
1-X-9		Case, for clutch (for four plates)	1	350	18	0
1-X-10		Case, for clutch (for five plates)	1	500	18	0
OF-33-3		Rivet, for clutch case and chainwheel	8	All		1
7-X-A-4		Chainwheel and clutch case, assembled	1	350	2	9 0
7-X-A-5		Chainwheel and clutch case, assembled	1	500	2	9 0
<i>For the bare chainwheel and its roller bearing, see CLUTCH SPROCKET, in the transmission Section, page 17.</i>						
2-X-15		Centre, for four plate clutch	1	350	1	10 0
2-X-16		Centre, for five plate clutch	1	500	1	10 0
69-X-2		Nut, retaining centre to mainshaft	1	All		9
349-X-3		Washer, lock, for centre retaining nut	1	All		4
<i>The above nut and washer are fitted to late gear boxes and, together, can replace the nut and two washers below.</i>						
69-X-1		Nut, retaining centre to mainshaft	1	All		9
71-X		Washer, plain, for centre retaining nut	1	All		4
212-X		Washer, spring, for centre retaining nut	1	All		4
<i>The nut and washers, above, are only used on early gear boxes.</i>						
6-X-2		Plate, clutch, plain, steel, thick	1	All	3	9
5-X-1		Plate, clutch, plain, steel, thin	4	350	3	0
5-X-1		Plate, clutch, plain, steel, thin	5	500	3	0
3-X-2		Plate, clutch, friction, with inserts	4	350	7	6
3-X-2		Plate, clutch, friction, with inserts	5	500	7	6
4-X-2		Inserts, fabric, for friction plate, per dozen	96	350	1	1
4-X-2		Inserts, fabric, for friction plate, per dozen	120	500	1	1
18-X-8		Plate, spring pressure, for clutch	1	All	13	6
21-X-3		Spring, for clutch	4	All		9
22-X-2		Cup, for clutch spring	4	All		9
24-X-11		Stud, for clutch spring, four plate clutch	4	350		6
24-X-12		Stud, for clutch spring, five plate clutch	4	500		6
23-X-3		Nut, adjusting, for clutch spring	4	All		6
CLUTCH OPERATING PARTS.						
28-X-56		Rod, thrust, for four plate clutch, 9 $\frac{1}{2}$ in.	1	350	1	6
28-X-57		Rod, thrust, for five plate clutch, 10 $\frac{1}{2}$ in.	1	500	1	6
330-X-1		Plunger, clutch operating	1	All		9
67-X-1		Ball, steel, for clutch operating plunger	1	All		1
175-X-4		Lever, clutch operating	1	All	3	0
66-X-7		Pin, for clutch operating lever	1	All	1	1
329-X-1		Fork, for clutch operating lever	1	All	2	3
331-X-1		Sleeve, for clutch operating lever fork	1	All		9
328-X-1		Cap, covering clutch operating lever fork sleeve	1	All	2	3
64-X-1		Screw, fixing sleeve cap to kick-starter case cover	2	All		6
KICK-STARTER.						
186-X-1		Ratchet, driving, kick-starter	1	All	8	7
183-X-1		Pinion, ratchet, kick-starter	1	All	12	0
184-X-1		Bush, kick-starter ratchet pinion	1	All	3	9
185-X-1		Spring, kick-starter ratchet pinion	1	All	1	1
70-X-1		Nut, retaining driving ratchet to mainshaft	1	All		6
198-X-5		Spindle, for kick-starter quadrant and foot lever	1	All	11	3
201-X-2		Bush, in K-S case, for K-S quadrant spindle	1	All	3	0
200-X-7		Bush, in K-S case cover, for K-S quadrant spindle	1	All	3	0
199-X-3		Quadrant, for kick-starter spindle	1	All	15	9
199-X-3-A-49		Kick-starter quadrant and spindle, assembled	1	All	1	7 0
130-X-2		Spring, return, for kick-starter foot lever	1	All	4	0
132-X-2		Pin, anchor, for kick-starter return spring	1	All		4
320-X-1		Stop, rubber, and sleeve, for K-S quadrant	1	All		9
202-X-1		Peg, for K-S stop rubber and sleeve	1	All		9
194-X-26		Lever, foot, kick-starter, bare	1	All	15	9
115-X-1		Pin, pedal, for kick-starter foot lever	1	All	4	6
315-X-1		Bolt, clamping K-S foot lever to spindle	1	All	1	1
144-X-1		Nut, for K-S foot lever clamping bolt	1	All		9
12-4-1		Washer, spring, on K-S lever bolt	1	All		1
OF-42		Washer, felt, on K-S spindle	1	All		4
OF-73		Washer, plain, retains felt washer on K-S spindle	1	All		3

FRAME SECTION.

PART NUMBER.		DESCRIPTION.	QTY.	USED ON.	PRICE EACH
OLD	NEW				
FRAME.					
013772	...	Frame, front portion only, bare.....	1	All	5 7 3
013773	...	Frame, rear portion only, bare.....	1	All	6 10 0
STD-597	...	Bolt, for seat lug (below saddle).....	1	All	10
STD-15	...	Screw, securing earth wires (Screws into end of bolt STD-597).....	1	All	1
STD-185	...	Washer, plain, for earth wire screw.....	1	All	1
STD-8	...	Washer, plain, for seat lug bolt.....	2	All	1
STD-1	...	Nut, for seat lug bolt.....	2	All	4
STD-303	...	Bolt, for seat tube bottom lug.....	1	All	6
013826	...	Spacer, for seat tube bottom lug bolt, left.....	1	All	6
013827	...	Spacer, for seat tube bottom lug bolt, right.....	1	All	6
STD-3	...	Nut, for seat tube bottom lug bolt.....	2	All	3
011238	...	Bolt, uniting front and rear frame.....	1	All	6
STD-11	...	Washer, plain, for frame uniting bolt.....	2	All	1
STD-4	...	Nut, for frame uniting bolt.....	2	All	3
41-G3L-F32	...	Bolt, adjusting, rear chain.....	2	All	1 2
STD-5	...	Nut, for rear chain adjusting bolt.....	2	All	3
STD-51	...	Nipple, grease, for head lug.....	1	All	3
STD-806	...	Ball race, for frame head lug.....	2	All	3 10
STD-72	...	Balls, $\frac{3}{8}$ in. diameter, for steering head, per set.....	56	All	1 7
013677	...	Plate, engine, rear.....	2	All	9 10
010819	...	Plate, engine, front.....	2	All	3 3
010823	...	Bolt, fixing front plate to frame tube.....	1	All	6
STD-10	...	Washer, plain, for front engine plate bolt.....	2	All	1
STD-3	...	Nut, for bolt fixing front engine plate.....	2	All	3
014202	...	Cover, rear engine plate.....	1	All	1 9
STD-413	...	Bolt, for plate cover.....	1	All	6
STD-10	...	Washer, plain, cover bolt.....	1	All	1
014194	...	Bracket, long, for horn.....	1	All	1 3
014195	...	Bracket, short, for horn.....	1	All	5

FORK ASSEMBLIES.

014833	...	Front fork assembly, solo.....	1	All	16 16 0
014834	...	Front fork assembly, sidecar.....	1	All	16 16 0

A front fork assembly comprises all the parts listed in the FRONT FORK group on pages 23 and 25, except the speedometer head bracket with its two fixing washers and bolts.

For ease of servicing, the inner tube unit is listed, and supplied, as a separate assembly. These enable a complete assembly to be exchanged in minimum time. They are listed below.

013638	...	Front fork inner tube assembly, solo.....	2	All	2 14 9
014836	...	Front fork inner tube assembly, sidecar.....	2	All	2 14 9

The above assembly comprises all those parts in the FRONT FORK, page 25, that are marked A.

FRONT FORK.

013861	...	Crown assembly, comprising crown, stem and circlip.....	1	All	1 8 11
STD-805	...	Ball race, for fork crown.....	1	All	5 2
011755	...	Stud, pinch, for fork crown.....	2	All	10
STD-11	...	Washer, plain, for fork crown pinch stud.....	2	All	1
013631	...	Lug, for handlebar and steering head.....	1	All	2 4 0
011635	...	Nut, fork crown pinch stud.....	2	All	7

The above handlebar lug includes the handlebar half clip and its studs with washers and nuts. For the part numbers and prices of those items see HANDLEBAR, on page 27.

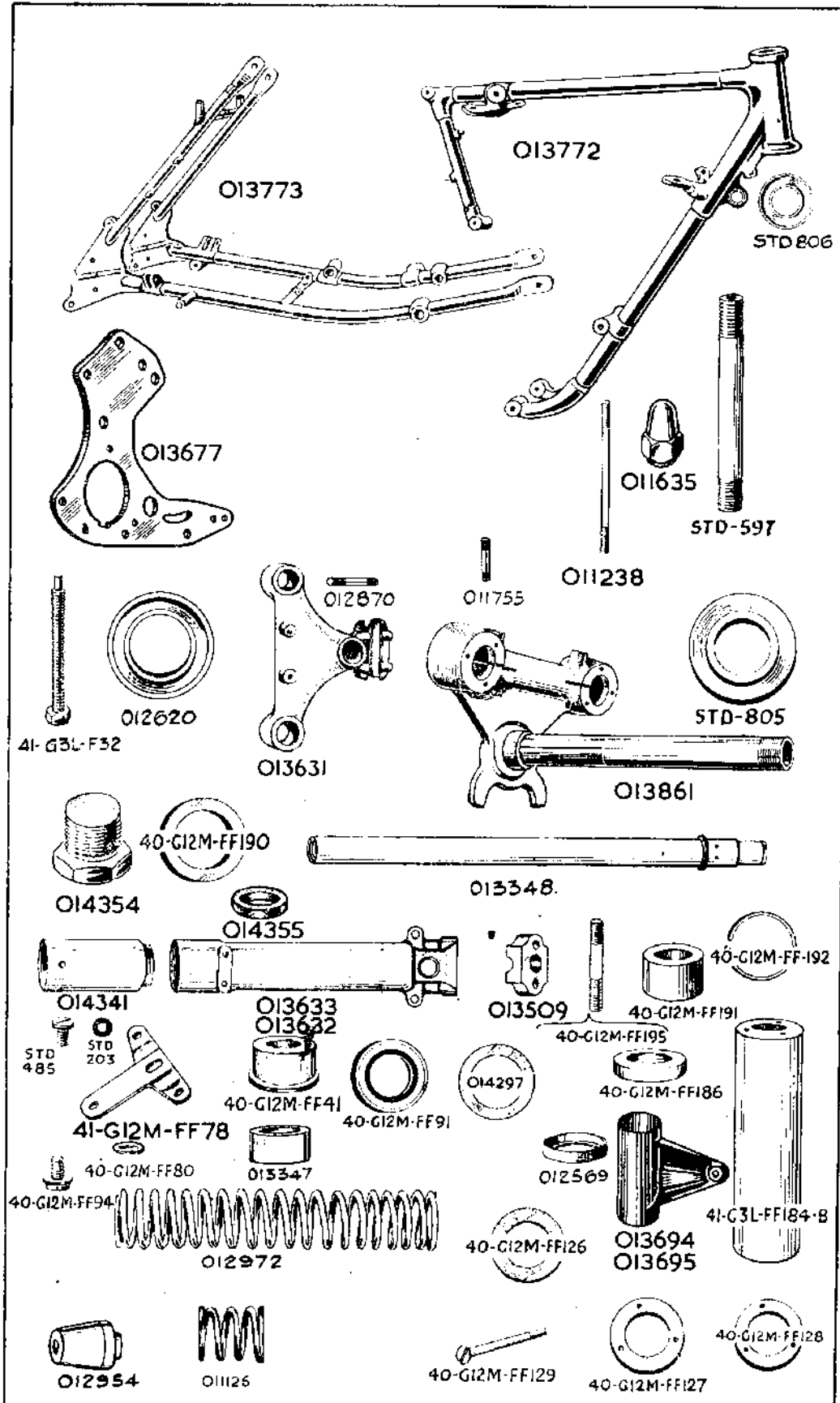

This scan is explicit for non-commercial use and is not intended for financial or material gain by anyone

PART NUMBER.	DESCRIPTION.	QTY.	USED ON.	PRICE EACH	
				£	s. d.
012620	Ball race, for handlebar lug.	1	All	3	10
STD-51	Nipple, grease, for handlebar lug.	1	All		3
STD-236	Nut, adjusting, for fork crown stem.	1	All	1	1
L4-FF46	Nut, lock (domed), for fork crown stem.	1	All	2	5
013348	Tube, fork inner	A 2	All	11	7
40-G12M-FF191	Bush, bottom, fork inner tube.	A 2	All	4	1
40-G12M-FF192	Circlip, fork inner tube bottom bush.	A 2	All		1
014354	Bolt, top, fork inner tube.	A 2	All	1	6
014355	Ring, sealing, for inner tube top bolt.	A 2	All		3
40-G12M-FF190	Washer, plain, fork inner tube top bolt.	A 2	All		4
013633	Slider, fork, left side, with cap, studs and nuts.	1	All	2	10
013632	Slider, fork, right side, with cap, studs and nuts.	1	All	18	0
013509	Cap, for slider, left or right.	2	All	4	1
014341	Extension, for fork slider.	A 2	All	7	5
40-G12M-FF41	Bush, bakelite, guide, fork inner tube.	A 2	All	2	2
40-G12M-FF91	Oil seal, for fork inner tube.	A 2	All	5	3
014297	Washer, composition, for inner tube oil seal.	A 2	All		2
012972	Spring, for front fork (main) solo.	A 2	All	6	6
41-G3L-FF32	Spring, for front fork (main) sidecar.	A 2	All	6	6
011126	Spring, for front fork (Buffer).	A 2	All		10
011862	Spacer, $\frac{3}{4}$ in. top, for sidecar main spring.	A 2	All	2	3
013868	Spacer, $\frac{1}{2}$ in. bottom, for sidecar main spring.	A 2	All		9
40-G12M-FF126	Washer, leather, fork spring seating.	A 4	All		3
013695	Tube, fork cover, top, left, with lamp lug.	1	All	8	6
013694	Tube, fork cover, top, right, with lamp lug.	1	All	8	6
40-G12M-FF186	Cap, for fork top cover tube (top).	2	All	1	2
012569	Cap, for fork top cover tube (bottom).	2	All		9
40-G12M-FF128	Plate, threaded, locating top cover tube.	2	All		6
41-G3L-FF184-B	Tube, fork cover, bottom.	2	All	3	3
40-G12M-FF127	Plate, plain, locating bottom cover tube.	2	All		3
40-G12M-FF129	Screw, retaining both locating plates.	6	All		3
STD-485	Screw, plug, oil drain, fork slider.	2	All		1
STD-203	Washer, fibre, fork slider oil level screw.	2	All		1
013347	Shuttle for damper.	A 2	All	1	5
012954	Cone for damper.	2	All		10
40-G12M-FF80	Washer, fibre, damper cone bolt.	2	All		1
40-G12M-FF94	Bolt, fixing damper cone to slider.	2	All		7
40-G12M-FF195	Stud, securing fork slider cap.	4	All		4
STD-4	Nut, fork slider cap securing stud.	4	All		3
STD-11	Washer, plain, fork slider cap securing stud.	4	All		1

STEERING DAMPER *(This is an optional extra).*

013458	Damper, steering, complete set of parts.	1	All	15	0
12361	Knob, steering damper.	1	All	3	6
STD-162	Washer, ratchet, steering damper knob.	1	All		3
STD-195	Washer, spring, steering damper knob.	1	All		4
010808	Cap, top of steering column.	1	All		6
010807	Drawbolt, for steering damper.	1	All	1	2
40-G12M-FF97A	Sleeve assembly, lower end of drawbolt.	1	All	5	9
STD-73	Nut, locking sleeve to drawbolt.	1	All		3
STD-70	Bolt, fixing sleeve assembly.	1	All		3
STD-191	Washer, spring, for sleeve assembly bolt.	1	All		1
STD-12	Washer, plain, for sleeve assembly bolt.	1	All		1
40-G12M-FF97	Plate, anchor, top position.	1	All		9
STD-70	Bolt, fixing top anchor plate.	1	All		3
STD-191	Washer, spring, top anchor plate.	1	All		1
STD-812	Washer, fibre, friction, for damper.	2	All		4
STD-236	Nut, lock, for fork crown stem (17).	1	All	1	1

NOTE 17.—Nut STD-236 replaces the domed lock nut L4-FF46 when a steering damper is fitted

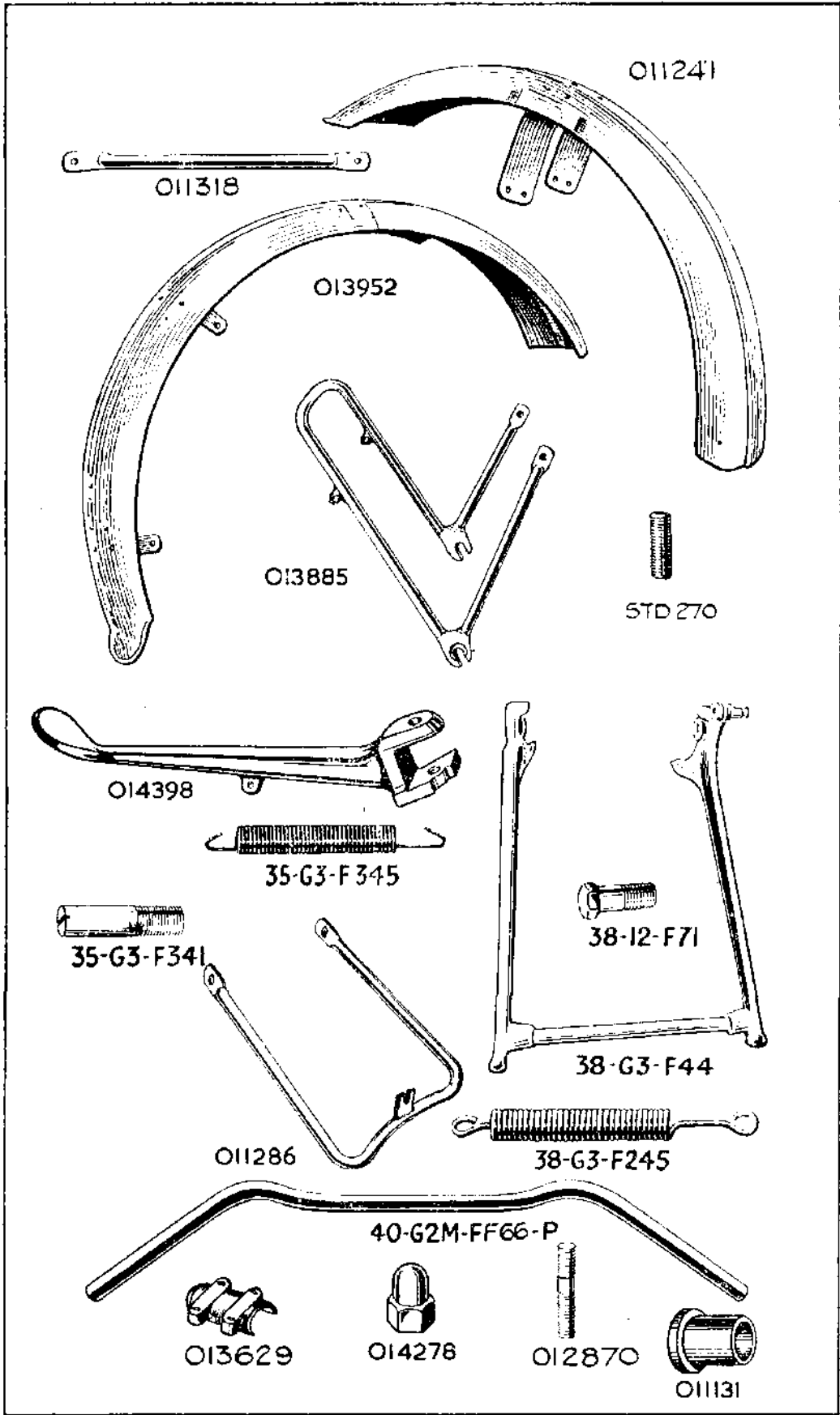

This scan is explicit for non-commercial use and is not intended for financial or material gain by anyone

PART NUMBER.		DESCRIPTION.	QTY.	USED ON.	PRICE EACH		
OLD	NEW				£	s.	d.
HANDLEBAR.							
40-G2M-FF66-P	...	Handlebar, bare (chrome plated)	1	All	1	6	3
011131	...	Plug, for ends of handlebar	2	All			9
013629	...	Clip, half only, for handlebar lug	1	All		6	6
012870	...	Stud, for handlebar clip	4	All			4
STD-12	...	Washer, plain, handlebar clip stud	4	All			1
014278	...	Nut, handlebar clip stud	4	All			6
FRONT STAND.							
011286	...	Stand, front, bare	1	All		8	3
41-G3L-FF422	...	Bolt, fixing stand to slider	2	All			10
HBD-52	...	Washer, spring, front stand fixing bolt	2	All			3
STD-14	...	Pin, split, front stand fixing bolt	2	All			1
STD-342	...	Bolt, fixing front stand to front guard	1	All			3
STD-5	...	Nut, front stand guard bolt, and stand fixing	1	All			3
014278	...	Nut (domed) front stand to guard bolt	1	All			6
STD-12	...	Washer, plain, front stand bolt	2	All			1
REAR STAND.							
38-G3-F44	...	Stand, rear, bare	1	All	1	12	2
38-12-F71	...	Bolt, fixing, stand to fork end	2	All			10
STD-8	...	Washer, plain, rear stand fixing bolt	2	All			1
STD-71	...	Nut, rear stand fixing bolt	2	All			4
38-G3-F245	...	Spring, return, rear stand	1	All		2	5
PROP STAND.							
014398	...	Stand, prop, bare	1	All		15	0
35-G3-F341	...	Bolt, hinge, prop stand leg	1	All			6
STD-49	...	Pin, split, prop stand hinge bolt	1	All			1
014139	...	Nut, prop stand hinge bolt	1	All			4
35-G3-F345	...	Spring, return, prop stand	1	All		1	4
FRONT MUDGUARD.							
011241	...	Mudguard, front, bare	1	All	1	0	7
41-G3L-M38	...	Bolt, fixing mudguard bracket to slider	4	All			4
STD-192	...	Washer, spring, mudguard bracket bolt	4	All			1
011318	...	Stay, front mudguard	2	All	1		1
41-G3L-M38	...	Bolt, fixing stay to fork slider	2	All			4
STD-192	...	Washer, spring, stay to fork slider bolt	2	All			1
STD-70	...	Bolt, fixing stay to front mudguard	2	All			3
STD-191	...	Washer, spring, stay to front mudguard bolt	2	All			1
STD-12	...	Washer, plain, stay to front mudguard bolt	2	All			1
STD-5	...	Nut, stay to front mudguard bolt	2	All			3
REAR MUDGUARD							
013952	...	Mudguard, rear, bare	1	All	1	13	0
<i>Although the above mudguard is made in two pieces the parts are not sold as separate spares.</i>							
STD-5	...	Nut, uniting halves of rear mudguard	2	All			3
STD-12	...	Washer, plain, for mudguard uniting bolt	2	All			1
STD-346	...	Bolt, fixing mudguard to frame bridges	2	All			4
STD-191	...	Washer, spring, mudguard bridge bolt	2	All			1
STD-5	...	Nut, rear mudguard bridge bolt	2	All			3
STD-342	...	Bolt, fixing guard to oil tank bracket	1	All			3
STD-172	...	Washer, plain, oil tank bracket bolt	1	All			1
STD-5	...	Nut, oil tank bracket bolt	1	All			3
013885	...	Arch, tubular, rear mudguard	1	All	1	5	0
STD-270	...	Stud, in fork end, for mudguard arch	2	All			3
STD-74	...	Nut, locking stud in fork end	2	All			3
STD-213	...	Nut, (with collar) locking rear mudguard arch to fork end stud	2	All			4
STD-368	...	Bolt, fixing mudguard to rear of arch	2	All			4
STD-363	...	Bolt, fixing mudguard to front of arch, left side	1	All			4
STD-363	...	Bolt, fixing mudguard to front of arch, right side, also secures tool box stay	1	All			4
STD-192	...	Washer, spring, mudguard arch bolt	4	All			1
STD-4	...	Nut, rear mudguard arch bolt	4	All			3

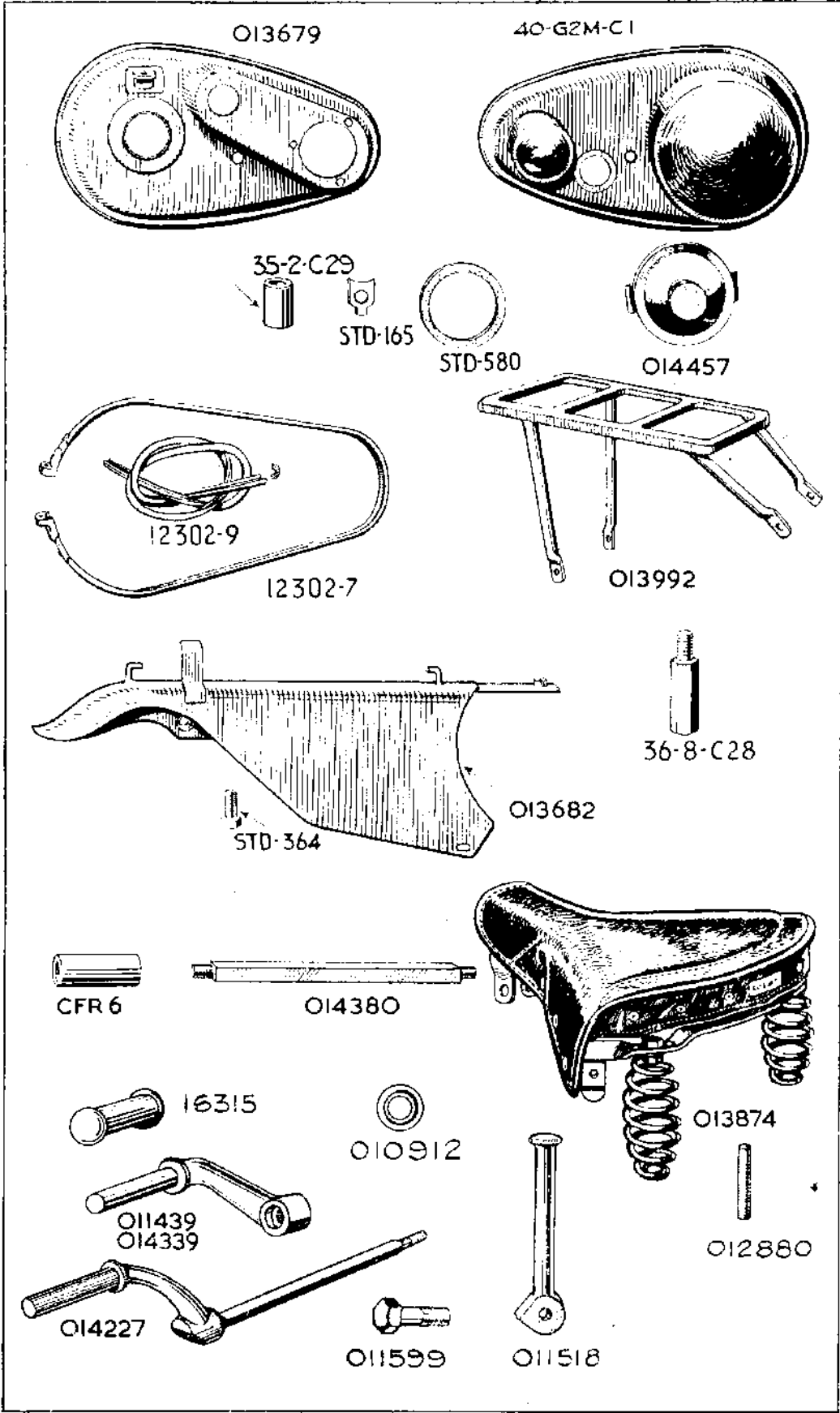

This scan is explicit for non-commercial use and is not intended for financial or material gain by anyone

PART NUMBER.	DESCRIPTION.	QTY.	USED ON.	PRICE EACH		
				£	s.	d.

REAR CARRIER (This is an optional extra).

013992	Carrier, rear, bare.....	1	All	1	2	3
STD-364	Mudguard arch bolt, front, right, replaces STD-363 when carrier is fitted.....	1	All			6

FRONT NUMBER PLATE.

011835	Plate, number, front.....	1	All	2	10	
011836	Stud, fixing front plate.....	2	All	1	0	
STD-5	Nut, front number plate stud.....	2	All			3
STD-12	Washer, plain, front number plate stud.....	2	All			1
011889	Fillet, rubber, front number plate.....	1	All			5
STD-861	Screw, fixing front plate to stud.....	2	All			1

REAR NUMBER PLATE.

014260	Plate, number, rear.....	1	All	8	8	
STD-363	Bolt, fixing rear number plate.....	2	All			4
STD-192	Washer, spring, number plate bolt.....	2	All			1
39-G3-EQ13	011094 Bush, rubber, rear lamp cable.....	1	All			4

FRONT CHAINCASE.

014534	Chaincase, complete (18).....	1	All	2	16	9
013679	Chaincase, back half, bare.....	1	All	1	0	7
40-G2M-C1	Chaincase, front half, bare.....	1	All	1	6	4
12302-7	Band, metal, for chaincase.....	1	All	8	3	
STD-453	Screw, clamping chaincase metal band.....	1	All			3
12302-9	Band, rubber, for chaincase.....	1	All			10
014457	Cap, assembly, chaincase inspection (19).....	1	All	2	2	
STD-580	Washer, cork, chaincase inspection cap.....	1	All			3
STD-440	Bolt, fixing chaincase to engine.....	3	All			3
STD-165	Washer, lock, chaincase engine bolt.....	3	All			1
STD-316	Bolt, fixing centre of chaincase (20).....	1	All	1	2	
39-G9-C27	010953 Spacer, centre bolt, between chaincase and engine plate 1 1/8 in.....	1	All			4
35-2-C29	Spacer, centre bolt, inside case 3/8 in.....	1	All			4
STD-9	Washer, plain, chaincase centre bolt.....	2	All			1
STD-166	Washer, plain (thin), chaincase bolt (outside case).....	1	All			1
STD-2	Nut, chaincase centre bolt.....	3	All			4

NOTE 18.—"Chaincase, complete" comprises, Back and front halves of chaincase, metal band with rubber band and clamping screw and complete inspection cap. NO FIXING BOLTS, SPACERS, WASHERS AND NUTS ARE INCLUDED.

NOTE 19.—A "Cap, assembly" comprises the cap with its central screw, back plate and cork washer. The cap, central screw and back plate are not sold as separate spares because the central screw is "burred" after assembly.

NOTE 20.—Also see crankcase bolts, page 9.

REAR CHAINGUARD.

013682	Chainguard, rear, bare.....	1	All	1	8	10
36-8-C28	Bolt, fixing top of chainguard in front.....	1	All			6
STD-70	Bolt, fixing bottom of chainguard in front.....	1	All			3
STD-12	Washer, plain, bottom front bolt.....	1	All			1
STD-5	Nut, bottom, front chainguard bolt.....	1	All			3
STD-364	Bolt, fixing rear of chainguard.....	1	All			6
STD-11	Washer, plain, for chainguard rear bolt.....	1	All			1
014584	Clip, for oil tank vent pipe.....	1	All			3

PART NUMBER.	DESCRIPTION.	QTY.	USED ON.	PRICE EACH	
				OLD	NEW

BATTERY CARRIER.

014835	Carrier, battery, complete (21), chrome front.....	1	All	17	0
013824	Carrier, battery, back portion only.....	1	All	11	6
012581	Carrier, battery, front portion only.....	1	All	7	6
X-E184	Pin, hinge, battery carrier front.....	1	All		3
012798	Bolt, clamping, battery carrier.....	1	All		6
A-E178	Seat, battery carrier clamping bolt.....	1	All		4
A-E177	Nut, battery carrier clamping bolt.....	1	All		7
STD-4	Nut, fixing carrier to main frame (22).....	2	All		3
STD-174	Washer, plain, carrier fixing nut (22).....	2	All		1
013840	Stay, battery carrier to chaincase.....	1	All		10
STD-40	Screw, fixing stay to battery carrier.....	1	All		1
STD-12	Washer, plain, battery stay screw.....	1	All		1

NOTE 21.—“Carrier, battery, complete,” includes front and back portions, hinge pin and clamping bolt with seat and nut.

NOTE 22.—Also serves to retain the oil tank to the main frame.

TOOL BOX.

011237	Box, tool, bare (23).....	1	All	1	0	7
37-8-F53	Screw, knurled, for tool box lid.....	1	All		1	7
STD-189	Washer, spring, tool box lid screw.....	1	All			1
STD-5	Nut, tool box lid screw.....	2	All			3
STD-342	Bolt, fixing tool box to seat stay.....	2	All			4
STD-639	Spacer, tool box seat stay bolt.....	2	All			3
STD-12	Washer, plain, tool box fixing bolt.....	4	All			1
STD-5	Nut, tool box fixing bolt.....	2	All			3
011738	Stay, for tool box.....	1	All			4
STD-361	Bolt, fixing stay to tool box.....	1	All			3
STD-11	Washer, plain, tool box stay bolt.....	1	All			1
STD-4	Nut, tool box stay bolt.....	1	All			3

NOTE 23.—Does not include the lid fixing screw assembly. That assembly (screw, spring washer and two nuts) is 2s. 2d. extra, making a total of £1 2s. 9d.

FOOT RESTS.

014227	Arm, footrest (with rod), left.....	1	All	11	8
014339	Arm, footrest, right.....	1	All	7	6
16315	010847 Pad, rubber, footrest arm.....	2	All	2	5
C-FR6	010924 Spacer, footrest rod, between plates.....	1	All	1	1
013837	Spacer, footrest rod, outside plates, right.....	1	All	1	1
010911	Spacer, footrest rod, outside plates, left.....	1	All		6
010912	Washer, spigot, footrest rod.....	1	All		2
STD-2	Nut, footrest rod.....	1	All		4

PILLION FOOT RESTS (These are optional extra equipment).

011267	Pair of pillion footrests, complete (24).....	1	All	12	3
011518	Spindle, bare, pillion footrest.....	2	All	3	3
011599	Bolt, hinge, pillion footrest spindle.....	2	All		6
STD-73	Nut, pillion footrest spindle hinge bolt.....	2	All		3
16315	010847 Pad, rubber, pillion footrest.....	2	All	2	5

NOTE 24.—“Pair of Pillion Footrests, complete,” comprises two spindles with two rubber pads and two hinge bolts and nuts.

PART NUMBER.	DESCRIPTION.	QTY.	USED ON.	PRICE EACH		
				OLD	NEW	£ s. d.

SADDLE.

013874	Saddle, with rear springs.....	1	...	All	...	3	1	5
013873	Saddle, less springs.....	1	...	All	...	2	11	5
38-G3-F60-T	Cover, saddle.....	1	...	All	...	19	9	
013993	Spring, saddle, rear.....	2	...	All	...	5	0	
STD-410	Bolt, saddle, front hinge.....	1	...	All	...		7	
STD-3	Nut, saddle hinge bolt.....	1	...	All	...		3	
012880	Stud, saddle spring (screws into frame).....	2	...	All	...		5	
STD-73	Nut, saddle spring stud.....	6	...	All	...		3	

PILLION SEAT *(This is optional extra equipment.)*

011291	Seat, pillion, with fixing bolts, washers and nuts.....	1	...	All	...	1	6	0
STD-70	Bolt, fixing pillion seat.....	4	...	All	...		3	
STD-191	Washer, spring, pillion seat bolt.....	4	...	All	...		1	
STD-12	Washer, plain, pillion seat bolt.....	4	...	All	...		1	
STD-5	Nut, pillion seat fixing bolt.....	4	...	All	...		3	

NAME TRANSFERS.

38-G3-F391	STD-9184	Transfer, for top of oil tank(Service instruction)	1	...	All	...	3			
38-G3-F392	STD-9183	Transfer, for side of oil tank(Oil level indicator)	1	...	All	...	3			
38-G3-F393	STD-9186	Transfer, for front chaincase(Oil level indicator)	1	...	All	...	3			
38-12-F383	010969	Transfer, for rear mudguard..... ("A.J.S.")	1	...	All	...	6			
STD-9185	...	Transfer, for tool box.....(Monogram)	1	...	All	...	4			
38-12-F383	010969	Transfer, for petrol tank..... ("A.J.S.")	2	...	All	...	6			
STD-9192	...	Transfer, for front forks.....(Patent)	1	...	All	...	6			
012973	...	Transfer, reserve, petrol tank.....(Reserve)	1	...	All	...	3			
014130	...	Set of Transfers, as above.....	1	...	All	...	3	4		

The lining on petrol tanks is applied by hand. Therefore transfers for that cannot be supplied.

CONTROL LEVER AND CABLE SECTION.

PART NUMBER.	DESCRIPTION.	QTY.	USED ON.	PRICE EACH		
				OLD	NEW	£ s. d.

TWIST GRIP.

16-117-CE	Twist grip, assembly.....	1	...	All	...	10	6	
16-070	Grip, rubber, for twist grip.....	1	...	All	...	1	0	
16-091	Rotor and sleeve, twist grip (25).....	1	...	All	...	3	6	
16-060	Body, twist grip, top.....	1	...	All	...	3	0	
16-061	Body, twist grip, bottom.....	1	...	All	...	3	0	
11-013	Screw, clamping, twist grip body.....	2	...	All	...		3	
16-008	Spring, friction, twist grip.....	1	...	All	...		9	
16-009	Screw, twist grip friction spring.....	1	...	All	...		6	
16-010	Nut, twist grip friction spring screw.....	1	...	All	...		2	
16-011	Stop, twist grip cable.....	1	...	All	...		6	

NOTE 25.—Does not include the rubber grip.

DUMMY GRIP.

16-069	Grip, rubber, dummy.....	1	...	All	...	1	6	
--------	-----	-----	--------------------------	---	-----	-----	-----	---	---	--

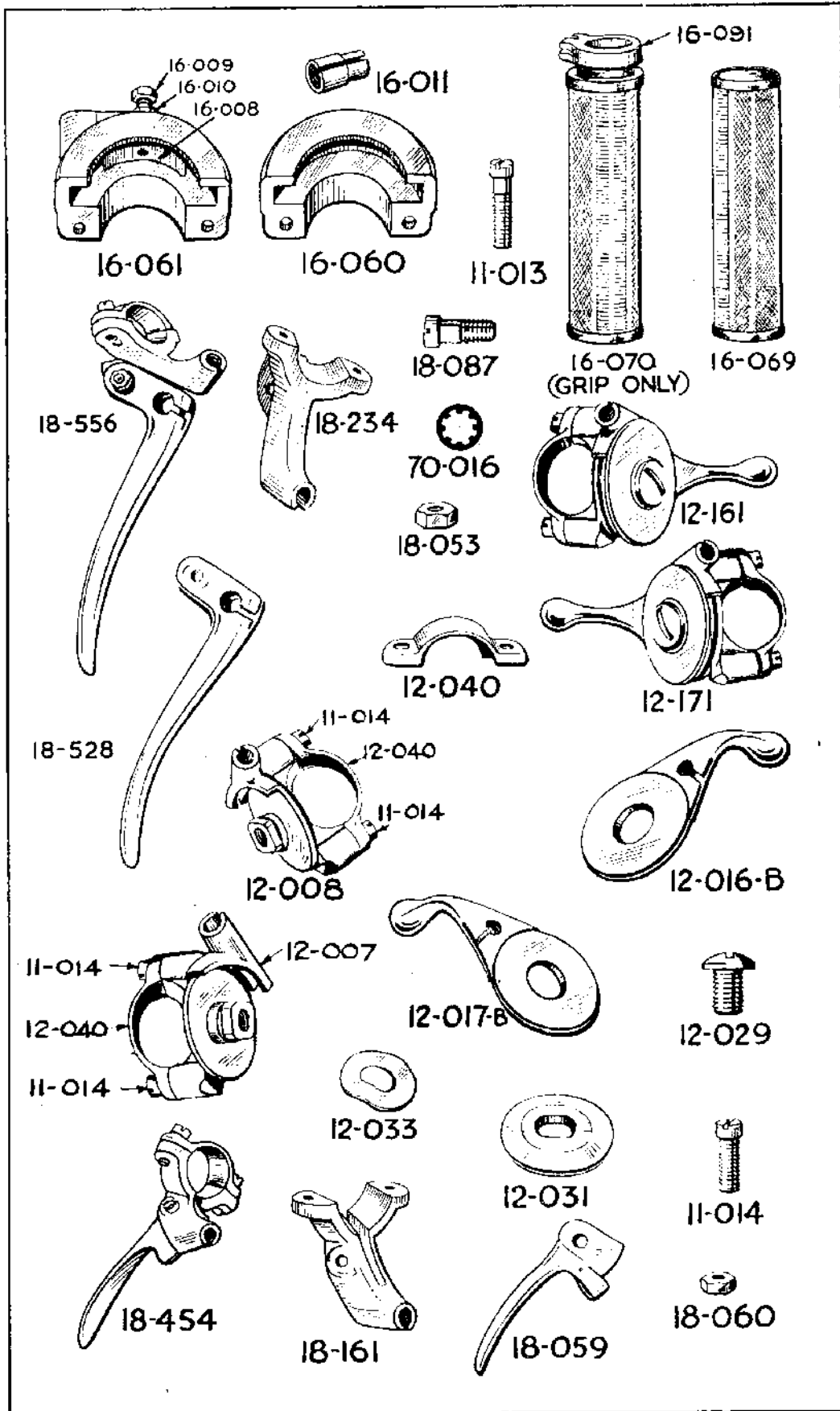

This scan is explicit for non-commercial use and is not intended for financial or material gain by anyone

PART NUMBER.	DESCRIPTION.	QTY.	USED ON.	PRICE EACH		
				OLD	NEW	£ s. d

CLUTCH CONTROL LEVER.

18-556	Lever, assembly, clutch.....	1	All	9	0
18-528	Lever, only, clutch.....	1	All	5	3
18-234	Bracket, clutch lever.....	1	All	5	3
12-040	Clamp, clutch lever bracket.....	1	All	9	
11-014	Screw, clutch lever bracket clamp.....	2	All	3	
18-087	Pin, fulcrum, clutch lever.....	1	All	3	
18-053	Nut, clutch lever fulcrum pin.....	1	All	3	
70-016	Washer, lock, clutch lever fulcrum pin nut.....	1	All	2	

FRONT BRAKE CONTROL LEVER.

18-557	Lever, assembly, brake.....	1	All	9	0
18-535	Lever, only, brake.....	1	All	5	3
18-234	Bracket, brake lever.....	1	All	5	3
12-040	Clamp, brake lever bracket.....	1	All	9	
11-014	Screw, brake lever bracket clamp.....	2	All	3	
18-087	Pin, fulcrum, brake lever.....	1	All	3	
18-053	Nut, brake lever fulcrum pin.....	1	All	3	
70-016	Washer, lock, brake lever fulcrum pin nut.....	1	All	2	

EXHAUST LIFTER CONTROL LEVER.

18-454	Lever, assembly, exhaust lifter.....	1	All	4	6
18-059	Lever, only, exhaust lifter.....	1	All	2	3
18-161	Bracket, exhaust lifter lever.....	1	All	1	9
12-040	Clamp, exhaust lifter lever bracket.....	1	All	9	
11-014	Screw, exhaust lifter lever bracket clamp.....	2	All	3	
11-014	Pin, fulcrum, exhaust lifter lever.....	1	All	3	
18-060	Nut, exhaust lifter lever fulcrum pin.....	1	All	3	

AIR CONTROL LEVER.

12-161	Lever, assembly, air.....	1	All	9	0
12-016-B	Lever, only, air.....	1	All	3	9
12-007	Bracket, air control lever.....	1	All	2	9

IGNITION CONTROL LEVER.

12-171	Lever, assembly, ignition.....	1	All	9	0
12-017-B	Lever, only, ignition.....	1	All	3	9
12-008	Bracket, ignition control lever.....	1	All	2	9

FITTINGS FOR AIR AND IGNITION CONTROL LEVERS.

12-040	Clamp, air or ignition lever bracket.....	2	All	9	
11-014	Screw, air or ignition lever bracket clamp.....	4	All	3	
12-029	Bolt, central, air or ignition lever.....	2	All	3	
12-031	Cap, air or ignition lever.....	2	All	8	
12-033	Washer, spring, air or ignition lever.....	2	All	2	

WHEN IN DOUBT REGARDING THE NAMES AND PART NUMBERS OF THE PARTS YOU REQUIRE, PLEASE SEND THE OLD PARTS TO SERVE AS PATTERNS.

THE COMPLETE CONTROL CABLES LISTED IN THE FOLLOWING SIX PARAGRAPHS INCLUDE ALL THE PARTS THAT MUST BE THREADED ON THE INNER CABLES BEFORE THE NIPPLES ARE FITTED. THEY ARE ASSEMBLED READY FOR USE.

THE INNER WIRES DO NOT INCLUDE THE NIPPLES AND THE OUTER CASINGS DO NOT INCLUDE THE END FERRULES.

PART NUMBER.	PART NUMBER.		DESCRIPTION.	QTY.	USED ON.	PRICE EACH	
	OLD	NEW				£	s. d.
FRONT BRAKE CABLE.							
013178	Cable, complete, assembled, front brake.....	1	All	6	3
011860	Wire, inner, front brake, finished length 40½ in.....	1	All		6
40-058	Nipple, brake end, brake inner wire.....	1	All		3
18-088	Nipple, handlebar end, brake inner wire.....	1	All		3
013177	Casing, outer, front brake.....	1	All	1	2
STD-531	Ferrule, front brake outer casing.....	2	All		1
011348	Adjuster, front brake cable.....	1	All	2	0
16363	Nut, lock, front brake cable adjuster.....	1	All		6
16482	End, yoke, front brake cable.....	1	All	1	4
STD-736	Pin, for yoke end, front brake cable.....	1	All		4
STD-14	Pin, split, brake, cable yoke end pin.....	1	All		1
012478	Sleeve, rubber, front brake cable.....	1	All		5
CLUTCH CABLE.							
41-C-2	Cable, complete, assembled, clutch.....	1	All	7	8
12-52	Wire, inner, clutch, finished length 50½ in.....	1	All	1	2
4	Nipple, gear box end, clutch inner wire.....	1	All		1
18-088	Nipple, handlebar, end clutch inner wire.....	1	All		3
12C-47	Casing, outer, clutch.....	1	All	3	3
STD-531	Ferrule, clutch outer casing.....	2	All		1
014225	Adjuster, clutch cable.....	1	All		7
STD-290	Nut, lock, clutch cable adjuster.....	1	All		3
VALVE LIFTER CABLE.							
014060	Cable, complete, assembled, exhaust lifter.....	1	All	5	5
12-25	Wire, inner, exhaust lifter, finished length 25 in.....	1	All		11
014061	Nipple, engine end, exhaust lifter inner wire.....	1	All		1
40-058	Nipple, handlebar end, exhaust lifter inner wire.....	1	All		3
12C-22½	Casing, outer, exhaust lifter.....	1	All	2	3
STD-531	Ferrule, exhaust lifter outer casing, H-Bar end.....	1	All		1
013998	Ferrule, lifter casing, engine end.....	1	All		3
014225	Adjuster, exhaust lifter cable.....	1	All		7
STD-290	Nut, lock, exhaust lifter cable adjuster.....	1	All		3
IGNITION CONTROL CABLE.							
45-I-1	Cable, complete, assembled, ignition.....	1	All	6	7
11-34	Wire, inner, ignition, finished length 34 in.....	1	All	1	1
MC-4	Nipple, magneto end, ignition inner wire.....	1	All		6
12-034	Nipple, handlebar end, ignition inner wire.....	1	All		2
11C-29	Casing, outer ignition.....	1	All	2	9
STD-528	Ferrule, ignition outer casing.....	2	All		1
MC-9	Cap, rubber, cable entry to magneto.....	1	All		3
MC-7	Adjuster, ignition cable.....	1	All		3
MC-8	Nut, lock, ignition cable adjuster.....	1	All		2
MC-6	Sleeve, ignition cable, screws into magneto.....	1	All		6
454969	Plunger, ignition cable.....	1	All		6
M3550-2	Washer, lock, ignition cable sleeve.....	1	All		2
MC-5	Spring, return, ignition cable.....	1	All		2

PART NUMBER.		DESCRIPTION.	QTY.	USED ON.	PRICE EACH
OLD	NEW				

THROTTLE CONTROL CABLE.

41-T-2		Cable, complete, assembled, throttle	1	350	5 3
45-T-2		Cable, complete, assembled, throttle	1	500	5 3
SW2-41		Wire, inner, throttle, finished length 39 $\frac{3}{4}$ in.	1	350	1 1
SW2-41 $\frac{1}{2}$		Wire, inner, throttle, finished length 40 $\frac{1}{2}$ in.	1	500	1 1
1482		Nipple, carburetter end, throttle inner wire	1	All	2
12-034		Nipple, handlebar end, throttle inner wire	1	All	2
11C-39		Casing, outer, throttle	1	All	2 5
STD-528		Ferrule, throttle outer casing	2	All	1

AIR CONTROL CABLE.

41-A-1		Cable, complete, assembled, air	1	350	5 3
45-A-1		Cable, complete, assembled, air	1	500	5 3
11-38		Wire, inner, air, finished length 37 in.	1	350	1 1
11-38 $\frac{1}{2}$		Wire, inner, air, finished length 37 $\frac{1}{2}$ in.	1	500	1 1
1482		Nipple, carburetter end, air inner wire	1	All	2
12-034		Nipple, handlebar end, air inner wire	1	All	2
11C-32		Casing, outer, air	1	All	2 0
STD-528		Ferrule, air outer casing	2	All	1

TANK SECTION.

PART NUMBER.		DESCRIPTION.	QTY.	USED ON.	PRICE EACH
OLD	NEW				

PETROL TANK.

014616		Tank, petrol, bare, chrome and panelled	1	All	10 4 0
014617		Tank, petrol, bare, enamelled and lined	1	All	7 14 0
38-G3-T15-A		Bolt, fixing tank (26)	4	All	10
38-G3-T15-A		Bolt, fixing tank (27) Air cleaner fitted	3	All	10
39-G3-T15		Bolt, fixing tank (27) Air cleaner fitted	1	All	3
16413		Pad, rubber, thick, tank fixing bolt (26) (27)	4	All	3
16414		Pad, rubber, thin, tank fixing bolt (26)	4	All	3
16414		Pad, rubber, thin, tank fixing bolt (27) Air cleaner fitted	3	All	3
STD-173		Washer, metal, plain, tank fixing bolt (26)	12	All	3
STD-173		Washer, metal, plain, tank fixing bolt (27) Air cleaner fitted	11	All	3
41-G3L-T68		Washer, metal, spigot, tank fixing bolt (27) Air cleaner fitted	1	All	10
41-G3L-T97		Wire, copper, 5 ft. by 20 S.W.G.	1	All	3

NOTE 26. Used in all four positions when an air cleaner is NOT fitted. See illustration 8 on page 24 of 1949 Maintenance Manual and Instruction Book for details of order of assembly.

NOTE 27. Used when an air cleaner is fitted. For the two front fixing bolts and the rear left bolt the order of assembly is as shown in illustration 8 on page 24 of the Manual but, on the bolt in the rear right position the lowermost metal washer (B) and the thin rubber pad (C) under it and the tank fixing bolt (D) are all discarded and one 41-G3L-T68 spigot washer and one 39-G3-T15 tank fixing bolt are used in lieu.

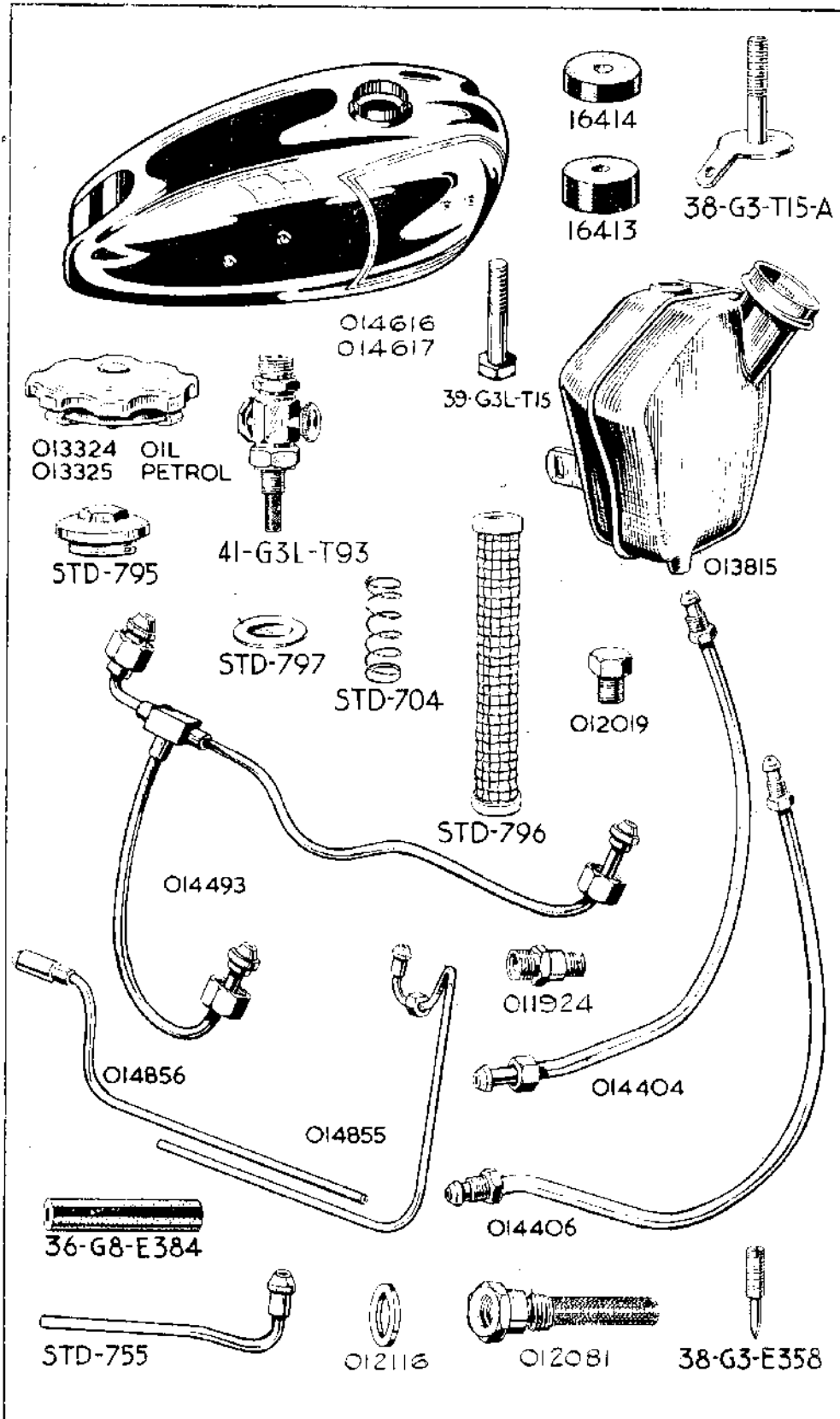

This scan is explicit for non-commercial use and is not intended for financial or material gain by anyone

PART NUMBER.	NEW		DESCRIPTION.	QTY.	USED ON.	PRICE EACH		
	OLD					£	s.	d.

PETROL TANK FITTINGS.

013325			Cap, filler, for petrol tank.....	1	All		6	6
41-G3L-T93			Tap, for petrol feed, with filter.....	2	All		4	11
STD-200			Washer, fibre, for petrol feed tap.....	2	All			3
37-8-T4-L		011006	Grip, knee, left hand side.....	1	All		4	1
37-8-T4-R		011005	Grip, knee, right hand side.....	1	All		4	1
37-8-T34-L		011008	Plate, for left hand knee grip.....	1	All			10
37-8-T34-R		011007	Plate, for right hand knee grip.....	1	All			10
STD-70			Bolt, fixing knee grip plate.....	4	All			3
STD-639			Spacer, knee grip plate bolt.....	4	All			3

OIL TANK.

013815			Tank, oil, bare.....	1	All	2	0	6
013324			Cap, filler, oil tank.....	1	All		6	6
012019			Plug, drain, for oil tank.....	1	All			4
STD-200			Washer, fibre, oil tank drain plug.....	1	All			3
STD-796			Filter, felt, for oil tank.....	1	All		4	1
STD-704			Spring, for oil tank felt filter.....	1	All			6
STD-797			Cap, metal, dished, for oil tank felt filter.....	1	All			4
STD-795			Cap, screwed, oil tank filter compartment.....	1	All		2	5
STD-583			Washer, cork, filter compartment cap.....	1	All			3

For the two nuts and washers that retain the oil tank (and the Battery carrier) to the main frame, see BATTERY CARRIER, page 30.

For the bolt, washer and nut, fixing the oil tank bracket to the rear mudguard, see REAR MUDGUARD, page 27.

PETROL PIPE.

014493			Pipe, assembly, petrol feed (28).....	1	All		9	1
--------	--	--	---------------------------------------	---	-----	--	---	---

OIL PIPES.

014404			Pipe, oil feed, assembly (28).....	1	All		7	3
014406			Pipe, oil return, assembly (28).....	1	All		6	9
014855			Pipe, rocker box oil feed, top half with union nut.....	1	All		3	5
014856			Pipe, rocker box oil feed, bottom half with union nut.....	1	All		5	0
014586			Pipe, vent (rubber), for oil tank.....	1	All		1	5
STD-755			Pipe, oil discharge, for release valve.....	1	All		1	7

NOTE 28.—The "nipples" on these pipes are formed integrally with the piping. Therefore union nuts cannot be removed or re-fitted.

OIL PIPE FITTINGS.

36-G8-E384			Connection, rubber, rocker oil feed pipe.....	1	All			10
STD-508			Union, oil, in rocker box.....	1	All			6
012081			Union, with filter, oil, feed from tank.....	1	All		2	2
011924			Union, oil feed pipe (engine end).....	1	All			0
012116			Washer, fibre, for oil feed union (Engine end).....	1	All			1
STD-504-N			Nut, union, top end rocker feed pipe.....	1	All			6
37-12-E385			Nut, union, bottom end rocker feed pipe.....	1	All		1	7
STD-504-N			Nut, union, oil discharge pipe.....	1	All			6
38-G3-E358			Screw, needle adjusting, valve feed (29).....	1	All			7
STD-290			Nut, lock, needle adjusting screw.....	1	All			3

NOTE 29.—This screws into the right-hand side of the cylinder head and regulates the oil feed to the inlet valve guide.

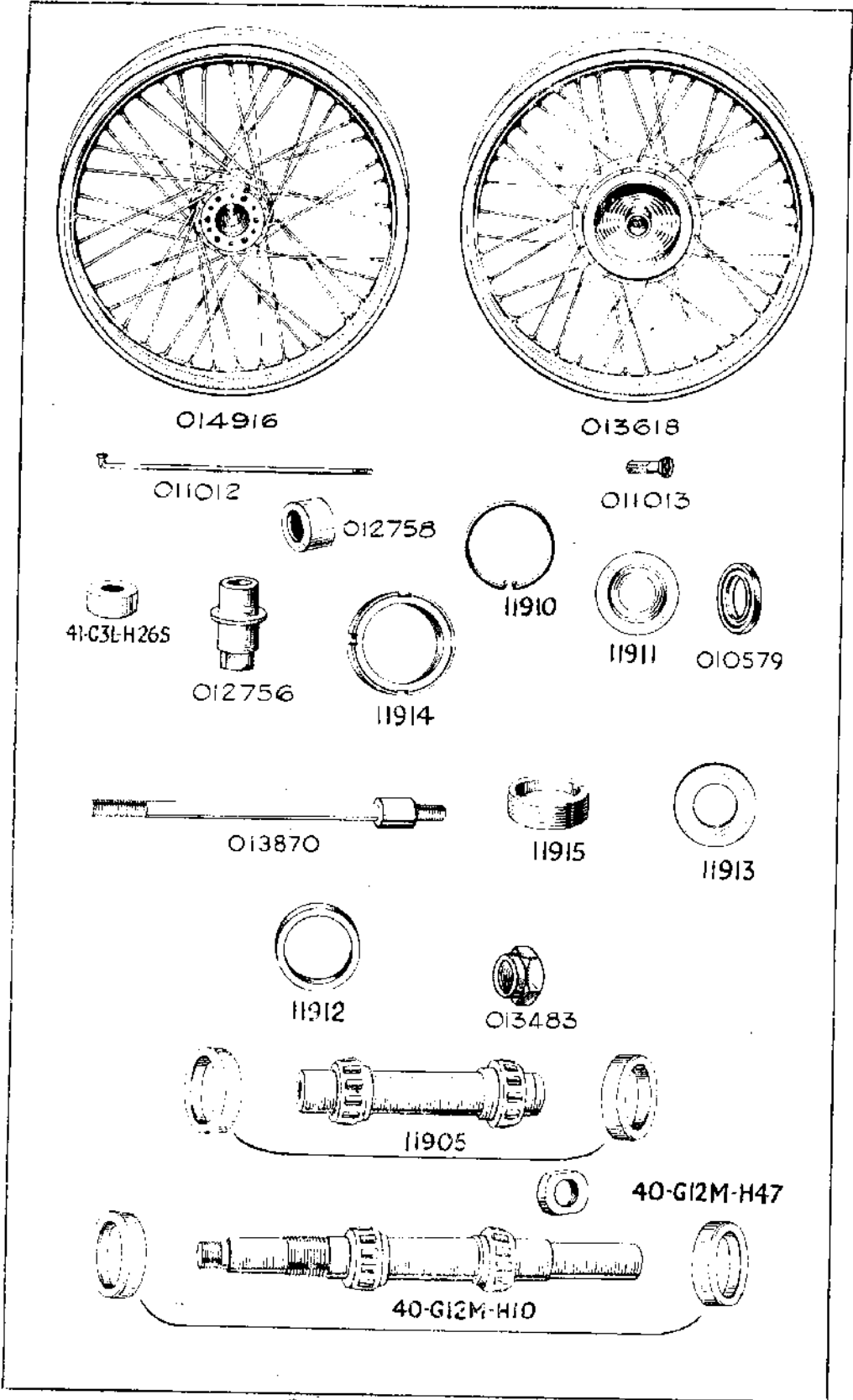

This scan is explicit for non-commercial use and is not intended for financial or material gain by anyone

WHEEL AND BRAKE SECTION.

PART NUMBER.	DESCRIPTION.	QTY.	USED ON.	PRICE EACH		
				£	s	d.
FRONT WHEEL.						
013608	Wheel, front, with all fittings (30).....	1	All	9	6	1
013618	Wheel, front, bare, less all fittings.....	1	All	5	0	2
012217	Rim, Front 19 in. by 2½ in.....	1	All	1	7	3
37-X-H51	011018 Spoke, front, left, 5¾ in. by 8G by 10G.....	20	All			3
12399	011014 Spoke, front, right, 8¾ in. by 9G by 11G.....	20	All			3
20680	011017 Nipple, front, left, 225 in. by 10G.....	20	All			1
20678	011016 Nipple, front, right, 225 in. by 11G.....	20	All			1
012575	Hub, front wheel, shell only, with brake drum.....	1	All	2	11	0
STD-51	Nipple, grease, for front wheel hub.....	1	All			3
011090	Tape, for 19 in. by 2½ in. rim.....	1	All			1 0

NOTE 30.—"Wheel, front, assembly, with all fittings" comprises: Rim, spokes, nipples, hub, all bearings and all brake parts including cover plate and expander lever, but does not include the tyre.

FRONT WHEEL BEARINGS.

40-G12M-H10	012825	Spindle, with roller bearings, front wheel.....	1	All	1	15	6
010579		Oil seal, for hub bearings.....	2	All			5
11910		Ring, spring, locating bearings in hub shell.....	1	All			3
11911		Cup, for hub bearing felt washer.....	1	All			4
11912		Ring, spacing, for hub bearing felt washer.....	1	All			6
11913		Ring, retaining felt washer.....	3	All			3
11914		Nut, lock, hub bearing adjusting ring.....	1	All		2	0
11915		Ring, adjusting, for hub bearing.....	1	All		2	5
40-G12M-H47		Nut, locating front brake cover plate.....	1	All			4
11913		Washer, locating front brake cover plate.....	1	All			3
013483		Nut, outside, securing front brake cover plate.....	1	All			8
STD-1		Nut, front wheel spindle, left side.....	1	All			4
STD-8		Washer, plain, front wheel spindle, left side.....	1	All			1

REAR WHEEL.

014915		Wheel, rear, with all fittings (31).....	1	All	6	7	9
014916		Wheel, rear, bare, less all fittings.....	1	All	3	19	0
012218		Rim, rear, 19 in. by 2½ in.....	1	All	1	7	3
39-8-H54	011012	Spoke, rear, left or right, 8¾ in. by 6G by 9G.....	40	All			3
12344	011013	Nipple, rear, left or right, 250 in. by 9G.....	40	All			1
41-G3L-H2		Hub, rear wheel, shell only.....	1	All	2	5	7
STD-51		Nipple, grease, for rear wheel hub.....	1	All			3
011090		Tape, for 19 in. by 2½ in. rim.....	1	All			1 0

NOTE 31.—"Wheel, rear, assembly, with all fittings" comprises: Rim, spokes, nipples, hub, all bearings, but does not include the centre solid spindle, washers, spacers, nuts, brake parts, sprocket and brake drum, speedometer drive and tyre.

REAR WHEEL BEARINGS.

11905	012837	Spindle, hollow, with roller bearings, rear wheel.....	1	All	1	8	10
010579		Oil seal, for hub bearings.....	2	All			5
11910		Ring, spring, locating bearings in hub shell.....	1	All			3
11911		Cup, for hub bearing felt washer.....	1	All			4
11912		Ring, spacing, for hub bearing felt washer.....	1	All			6
11913		Ring, retaining felt washer.....	3	All			3
11914		Nut, lock, hub bearing adjusting ring.....	1	All		2	0
11915		Ring, adjusting, for hub bearing.....	1	All		2	5
013870		Spindle, centre, solid, for rear wheel.....	1	All		4	1
012756		Spacer, rear solid spindle (next to cover plate).....	1	All		1	1
012758		Spacer, rear solid spindle (fits in fork end).....	1	All			9
41-G3L-H26-5		Spacer, rear solid spindle (for speedometer gear box).....	1	All			4
STD-2		Nut, rear solid spindle.....	2	All			4
STD-9		Washer, plain, rear solid spindle.....	2	All			1

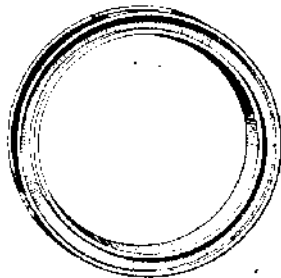

O10505



STD 372

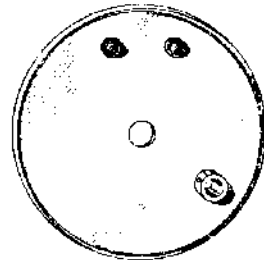

O12572

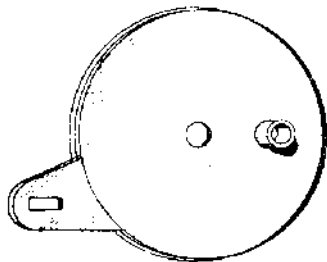

O12574



O13620

O13291

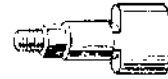

36-8-B51



16485



STD-51



O12576



O12577

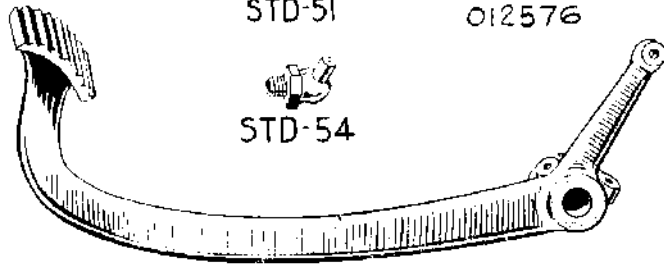

37-G3-B1



STD-54

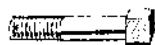

37-8-B7

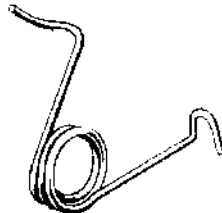

37-G3-B8

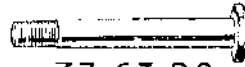

37-G3-B2

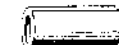

37-G3-B3



O11313



STD 736



STD-735



36-G3-B18



11772

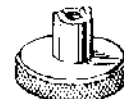

STD-615

PART NUMBER.	PART NUMBER.		DESCRIPTION.	QTY.	USED ON.	PRICE EACH		
	OLD	NEW				£	s.	d.

FRONT BRAKE.

010505	Drum, front brake, bare	1	...	All	...	17	11
STD-140	Screw, fixing front brake drum to hub shell.....	10	...	All	...		3
012572	Plate, cover, front brake	1	...	All	...	19	9
STD-372	Bolt, anchor, front brake cover plate.....	2	...	All	...		6
STD-11	Washer, plain, front brake anchor bolt.....	2	...	All	...		1
39-8-B71-A	013620	...	Shoes, pair of, for front brake, with brake linings and thrust pins—only supplied in pairs—per pair...	1	...	All	...	1	0 6
013291	Pin, thrust, brake expander adjusting.....	2	...	All	...		9
3836-2	010440	...	Linings, brake, per pair of, less rivets.....	1	...	All	...	4	0
STD-113	Rivets, for brake linings, per set of.....	12	...	All	...		2
16485	012892	...	Spring, for brake shoes.....	2	...	All	...		4
36-8-B51	012891	...	Expander, for brake shoes.....	1	...	All	...	4	1
012576	Lever, for front brake shoe expander.....	1	...	All	...	2	6
STD-51	Nipple, grease, for brake shoe expander.....	1	...	All	...		3
STD-174	Washer, plain, for brake shoe expander.....	1	...	All	...		1
STD-4	Nut, for brake shoe expander.....	1	...	All	...		3

REAR BRAKE.

012574	Plate, cover, rear brake.....	1	...	All	...	15	0
37-8-B7	Bolt, anchor, rear brake cover plate.....	1	...	All	...	1	3
STD-3	Nut, rear brake anchor bolt.....	1	...	All	...		3
STD-6	Pin, split, rear brake anchor bolt.....	1	...	All	...		1
39-8-B71-A	013620	...	Shoes, pair of, for rear brake, with brake linings and thrust pins—only supplied in pairs—per pair.....	1	...	All	...	1	0 6
013291	Pin, thrust, brake expander adjusting.....	2	...	All	...		9
3836-2	010440	...	Linings, brake, per pair of, less rivets.....	1	...	All	...	4	0
STD-113	Rivets, for brake linings, per set of.....	12	...	All	...		2
16485	012892	...	Spring, for brake shoes.....	2	...	All	...		4
36-8-B51	012891	...	Expander, for brake shoes.....	1	...	All	...	4	1
012577	Lever, for rear brake shoe expander.....	1	...	All	...	3	6
STD-51	Nipple, grease, for brake shoe expander.....	1	...	All	...		3
STD-174	Washer, plain, for brake shoe expander.....	1	...	All	...		1
STD-4	Nut, for brake shoe expander.....	1	...	All	...		3

REAR BRAKE OPERATING PARTS.

37-G3-B1	Pedal, rear, foot brake.....	1	...	All	...	12	4
37-G3-B3	Bush, rear brake foot pedal.....	1	...	All	...		10
STD-54	Nipple, grease, rear brake foot pedal.....	1	...	All	...		10
37-G3-B2	Spindle, rear brake foot pedal.....	1	...	All	...	1	2
STD-9	Washer, plain, rear brake pedal spindle.....	2	...	All	...		1
STD-194	Washer, spring, rear brake pedal spindle.....	1	...	All	...		1
STD-2	Nut, rear brake pedal spindle.....	1	...	All	...		4
37-G3-B8	Spring, return, rear brake foot pedal.....	1	...	All	...		10
STD-345	Bolt, adjusting, rear brake foot pedal.....	1	...	All	...		4
STD-5	Nut, lock, rear brake foot pedal adjusting bolt.....	1	...	All	...		3
011313	Rod, bare, rear brake.....	1	...	All	...	4	1
STD-735	End, yoke, front end of rear brake rod.....	1	...	All	...	1	4
STD-736	Pin, rear brake rod yoke end.....	1	...	All	...		4
STD-14	Pin, split, brake rod yoke end pin.....	1	...	All	...		1
36-G3-B18	Spring, rear brake rod.....	1	...	All	...		4
STD-178	Washer, plain, rear brake rod spring.....	1	...	All	...		1
11772	Clip, adjusting, rear end of rear brake rod.....	1	...	All	...	2	5
STD-736	Pin, rear brake rod adjusting clip.....	1	...	All	...		4
STD-14	Pin, split, brake rod adjusting clip pin.....	1	...	All	...		1
STD-615	Nut, knurled, adjusting, rear brake rod.....	1	...	All	...	2	10

ELECTRICAL SECTION.

PART NUMBER.		DESCRIPTION.	QTY.	USED ON.	PRICE EACH
OLD	NEW				
MAGNETO.					
42020-D		Magneto, type NI-3-A0.....	1	All	6 12 10
463066		Pick-up, with brush and spring.....	1	All	4 1
460061		Cover, contact breaker.....	1	All	1 2
460051		Contact breaker, complete.....	1	All	13 3
484098		Set of points, for contact breaker.....	1	All	5 2
464092		Tappet, for contact breaker.....	1	All	1 6
MAGNETO FIXING PARTS.					
010820		Platform, for magneto.....	1	All	7 5
STD-340		Bolt, fixing magneto, left, short.....	4	All	4
STD-12		Washer, plain, magneto fixing bolt.....	4	All	1
010824		Bolt, fixing platform at rear.....	1	All	8
010823		Bolt, fixing platform at front.....	1	All	10
010822		Spacer, platform rear fixing bolt.....	1	All	4
010821		Spacer, platform front fixing bolt.....	1	All	4
010817		Shield, for magneto.....	1	All	4 1
37-8-E291	010814	Clip, for magneto shield.....	2	All	10
010818		Plate, for magneto shield clip.....	2	All	6
STD-70		Bolt, fixing magneto shield.....	4	All	3
STD-12		Washer, plain, magneto shield bolt.....	8	All	1
STD-5		Nut, magneto shield bolt.....	4	All	3
DYNAMO.					
200430		Dynamo, type E3AR-A05-1.....	1	All	5 2 0
200290		Set of brushes, for dynamo.....	1	All	2 11
DYNAMO FIXING PARTS.					
39-G9-E275	010962	Strip, dynamo, locating.....	1	All	1 2
STD-44		Screw, fixing locating strip to dynamo.....	2	All	3
STD-25		Washer, plain, locating strip screw.....	2	All	1
F-E76		Strap, clamping dynamo.....	1	All	2 5
39-G9-E282	010963	Pin, hinge, dynamo clamping strap.....	1	All	6
35-G3-E277		Sleeve, threaded, eye of dynamo strap.....	1	All	7
41-G3L-E280		Bolt, tightening dynamo strap.....	1	All	1 1
39-8-E279	010926	Crossbar, square, dynamo clamping strap.....	1	All	2 0
VOLTAGE REGULATOR.					
35108-A		Regulator, complete Unic, Type MCR1-L31.....	1	All	1 17 5
STD-70		Bolt, fixing regulator to battery carrier.....	2	All	3
STD-12		Washer, plain, regulator fixing bolt.....	2	All	1
STD-5		Nut, regulator fixing bolt.....	2	All	3
BATTERY.					
PUW-7E	011255	Battery, with lid, dry and uncharged (32).....	1	All	1 15 4
PUW-7E (C)		Battery, with lid, filled and charged (33).....	1	All	1 17 7
S-2171		Cover, only, for battery, with rubber pads.....	1	All	2 0

NOTE 32.—This is a battery that has not been filled with electrolyte (acid) and is, of course, not charged. It requires no special packing and can safely be packed with other goods.

NOTE 33.—Filled with electrolyte and charged ready for use. Is only supplied to callers. In NO CIRCUMSTANCES do we pack and despatch this battery.

PART NUMBER.	DESCRIPTION.	QTY.	USED ON.	PRICE EACH		
				OLD	NEW	£ s. d.

HEAD LAMP.

50788-A	Headlamp w/ bulbs, ammeter and switch only.....	1	All	5	14	5
553428	Rim, bare, for head lamp.....	1	All		12	1
516364	Reflector, only, with glass.....	1	All		12	6
516368	Holder, for bulbs.....	1	All		8	8
112201	Bolt, fixing head lamp.....	2	All			7
137141	Washer, head lamp fixing bolt.....	2	All			5
106798	Screw, fixing panel.....	3	All			4
185026	Washer, panel fixing screw.....	3	All			1
516183	Fillet, rubber, for panel.....	1	All			3

REAR LAMP.

53139-A	Lamp, rear, complete w/ bulb.....	1	All	1	4	2
572611	Glass, red.....	1	All		6	11
572595	Gasket, for lamp base.....	1	All		1	2
572039	Gummet, for lamp wire.....	1	All			11
572040	Plug, rubber, for lamp base.....	1	All			11
572609	Frame, over red glass.....	1	All		11	6
572055	Screw, fixing glass frame.....	1	All			5
161385	Washer, for frame fixing screw.....	1	All			1
188818	Sleeve, for rear lamp wire.....	2	All			2
165310	Nut, rear lamp fixing screw.....	2	All			2

HORN.

069225	Horn, electric, with bracket only.....	1	All	1	18	6
STD-402	Bolt, fixing horn to engine plate.....	1	All			6
STD-10	Washer, plain, horn fixing bolt.....	1	All			1
STD-3	Nut, horn fixing bolt.....	1	All			3
701686	Bracket for horn.....	1	All		3	2

ELECTRICAL SUNDRIES.

364455	Ammeter, for head lamp panel.....	1	All		11	3
351551	Switch, main lighting, for head lamp panel.....	1	All		9	10
380521	Switch, dipping, for handlebar.....	1	All		6	1
762664	Switch, horn, for handlebar.....	1	All		5	2
351567	Handle, with screw, for main lighting switch.....	1	All		1	9
994001	Cable harness, main lighting (34) and Horn.....	1	All		13	7
858795	Cable harness, triple for dipping switch.....	1	All		4	0
989981	Cable Harness for Regulator.....	1	All		4	0
STD-543	Cable, high tension, for sparking plug, per foot.....	1	All			10
STD-541	Terminal, for high tension cable.....	1	All			3
STD-540	Terminal, for low tension earth wires.....	2	All			2
900269	Connector, for rear lamp cable.....	2	All		1	2
168	Bulb, head lamp, main, 6 volt, 24 by 24 watts.....	1	All		3	6
988	Bulb, head lamp, pilot, 6 volt, 3 watts.....	1	All			6
988	Bulb, rear lamp, 6 volt, 3 watts.....	1	All			6
H-14	Plug, sparking, Lodge type H-14.....	1	All		6	0

NOTE 34.—Does not include the triple wire from head lamp to handlebar dipping switch and the wires from Regulator.

CABLE CLIPS.

011907	Cable clip, 1½ in.	6	All			2
011908	Cable clip, 3 in.	5	All			2
011909	Cable clip, 4½ in.	4	All			2

ACCESSORY SECTION.

PART NUMBER.	DESCRIPTION.	QTY.	USED ON.	PRICE EACH	
				£	s. d.
SPEEDOMETER.					
011201	Speedometer, trip, 80 M.P.H., complete.....	1	350	4	0 0
011202	Speedometer, trip, 120 M.P.H. complete.....	1	500	4	0 0
011203	Speedometer, trip, 140 K.P.H., complete.....	1	350	4	0 0
011204	Speedometer, trip, 180 K.P.H., complete.....	1	500	4	0 0
S-433-1-L	Head, only, speedometer, trip, 80 M.P.H.....	1	350	2	10 0
S-433-5-L	Head, only, speedometer, trip, 140 K.P.H.....	1	350	2	10 0
S-480-3-L	Head, only, speedometer, trip 120 M.P.H.....	1	500	2	10 0
S-480-7-L	Head, only, speedometer, trip 180 K.P.H.....	1	500	2	10 0
53279-1	Set of bulb holding parts, for head.....	1	All	3	11
53205	Bulb, 6 volts, 1.8 watts, M.B.C. for head.....	1	All	1	6
N-1253	Nut, fixing speedometer head to bracket.....	2	All		2
STD-12	Washer, plain, spacing, for head.....	2	All		1
W-7216	Washer, spring, speedometer bracket nut.....	2	All		1
53395-1-54	Cable, speedometer drive, complete.....	1	All	1	0 0
52108-1-54	Cable, speedometer drive, inner only.....	1	All		10 0
53398-1-54	Cable, speedometer drive, outer only.....	1	All		10 0
41-G3L-F311	Clip, for speedometer drive cable.....	1	All		3
STD-450	Screw, fixing drive cable clip.....	1	All		1
STD-190	Washer, spring, drive cable clip screw.....	1	All		1
52283-2	Gear box, speedometer, complete.....	1	All	1	12 6
40-G12M-FF78	Bracket, for speedometer head.....	1	All		10
STD-341	Bolt, fixing speedometer bracket to forks.....	2	All		3
STD-12	Washer, plain, speedometer bracket bolt.....	2	All		1
COMPLETE TOOL KITS.					
014532	Tool kit, complete, with bag and tyre inflator.....	1	All	2	14 3
014533	Tool kit, complete, with bag but less tyre inflator .	1	All	2	6 9
TOOLS.					
The following comprise "1 Tool kit, complete, with bag and inflator" and is included as part of every new motor cycle.					
17520	Bag, for tools.....	1	All	4	1
L-TK13	Screwdriver.....	1	All	2	9
L-TK15	Pliers, sidecutting.....	1	All	3	10
11024	Pliers, for gudgeon pin circlips.....	1	All	1	7
L-TK20	Gun, grease.....	1	All	6	7
38-G3-EQ2	Inflator, tyre.....	1	All	7	6
40-G3-TK29	Lever, tyre.....	2	All	1	7
41-G3L-TK1	Spanner, double end, $\frac{3}{8}$ in. by $\frac{1}{2}$ in.....	2	All	2	5
41-G3L-TK2	Spanner, double end, $\frac{3}{8}$ in. by $\frac{3}{8}$ in.....	1	All	3	8
3263	Spanner, double end, $\frac{3}{8}$ inch. by .375 in. clutch cable adjustment.....	1	All	1	4
R-TK3	Spanner, triple end, .80 in. by 1.011 in. by 1.2 in.....	1	All	1	7
17634	Spanner, box, with tommy, sparking plug.....	1	All	1	7
R-TK1	Spanner, single end, dynamo chain adjustment.....	1	All		10
11914-S	Spanner, hook, for hub bearing lock nut.....	1	All	1	1
L-TK5	Spanner, double end, with gauge, contacts.....	1	All		10
L-TK12	Wrench, adjustable.....	1	All	9	0
SPECIAL TOOLS.					
11520-A	Holder, valve, for valve grinding.....			1	7
014605	Compressor, complete, for valve spring removal (35)	1	All	4	3
41-G3L-M38	Bolt, retaining compressor to head.....	2	All		4
014598	Disc, timing (See page 53 of Instruction book)	1	All	3	6
The above are NOT included as part of a new motor cycle.					
NOTE 35. Includes two 41-G3L-M38 bolts.					
VARIOUS.					
011957	Tekal, rust preventive, $\frac{1}{2}$ pint tin.....			2	0
011958	Tekal, rust preventive, 1 pint tin.....			2	6
B-A-H	Badge, Monogram, A.J.S., for button hole.....			1	6
B-A-T	Badge, Monogram, A.J.S., for tie.....			1	6
B-A-B	Badge, Monogram, A.J.S., brooch fixing.....			1	6

PARTS SPECIAL TO COMPETITION MODELS

This List only covers those parts which differ from Standard.

ENGINE SECTION

PART NUMBER.		DESCRIPTION.	QTY.	USED ON.	PRICE EACH
OLD	NEW				
CYLINDER					
013639	...	Plate, compression.....	1	350	2 10
011191	...	Plate, compression.....	1	500	2 10
39-B-E3	010927	Washer, paper, compression plate	2	All	3
<i>One Compression Plate is fitted to all Competition Models and one spare together with Paper Washer is provided in Tool Kit for use if desired to alter Compression Ratio.</i>					
PISTON					
011880	...	Piston, bare, H.C., 9-1 ratio.....	1	350	1 12 6
013705	...	Piston, complete, H.C., 9-1 ratio.....	1	350	2 3 6
011930	...	Piston, bare, H.C., 9-1 ratio.....	1	500	2 7 6
013706	...	Piston, complete, H.C., 9-1 ratio.....	1	500	3 0 0
PISTON .020 OVERSIZE					
013711	...	Piston, bare, H.C., 9-1 ratio.....	1	350	1 12 6
013712	...	Piston, complete, H.C., 9-1 ratio.....	1	350	2 3 6
013713	...	Piston, bare, H.C., 9-1 ratio.....	1	500	2 7 6
013714	...	Piston, complete, H.C., 9-1 ratio.....	1	500	3 0 0
PUSH ROD COVER TUBE					
38-G4-E379	...	Metal washer, top, used with no compression plate	2	350	4
38-G4-E379	...	Metal washer, top, used with one compression plate	4	350	4
38-G4-E379	...	Metal washer, top, used with two compression plates	6	350	4
38-G4-E379	...	Metal washer, top, used with no compression plate	2	500	4
014603	...	Metal washer, top, used with one compression plate	2	500	4
014603	...	Metal washer, top, used with two compression plates	4	500	4
GASKETS					
49-EQ-1C	...	Complete gasket set	1	350	8 1
49-EQ-2	...	Complete gasket set.....	1	500	8 1
49-EQ-3C	...	Decarbonizing gasket set	1	350	4 11
49-EQ-4	...	Decarbonizing gasket set.....	1	500	4 11

EXHAUST PIPE AND SILENCER SECTION

PART NUMBER.		DESCRIPTION.	QTY.	USED ON.	PRICE EACH
OLD	NEW				
EXHAUST PIPE					
011446	...	Pipe, exhaust.....	1	350	1 9 6
011449	...	Pipe, exhaust.....	1	500	1 16 9
014126	...	Pipe, exhaust, straight through.....	1	350	1 13 6
014128	...	Pipe, exhaust, straight through.....	1	500	2 0 0
014698	...	Stay, exhaust pipe.....	1	350	1 6
W41-G3L-E406	...	Stay, exhaust pipe.....	1	500	1 6
SILENCER					
011310	...	Silencer, bare.....	1	All	1 13 9
20470	...	Clip securing silencer to pipe.....	1	500	1 7
STD-367	...	Bolt, fixing silencer stay to frame.....	1	All	4
41-G3L-E567	...	Stay, for silencer.....	1	All	1 9

PART NUMBER	DESCRIPTION	QTY.	USED ON.	PRICE EACH	
				£	s. d.

OLD NEW

CARBURETTER SECTION

013927	Cover, for carburetter.....	1	...	All	...	5	5
--------	-----	-----	-----	-----------------------------	---	-----	-----	-----	---	---

TRANSMISSION SECTION

ENGINE SPROCKET

014016	Sprocket, engine, bare 16T.....	1	...	350	...	1	0	9
014018	Sprocket, engine, bare 18T.....	1	...	500	...	1	1	6

GEARBOX SECTION

SHAFTS AND GEARS

15-C-12	Gear, mainshaft driving, w/bushes 32T.....	1	...	All	...	2	8	0
24-C-4	Gear, third, on mainshaft 29T.....	1	...	All	...	18	9	
28-C-6	Gear, small, on layshaft 18T.....	1	...	All	...	15	0	
25-C-5	Gear, third, on layshaft 21T.....	1	...	All	...	15	0	

KICK STARTER

194-X-13	Lever, foot, kickstarter, bare.....	1	...	All	...	16	2	
115-X-2	Pin, pedal, kickstarter lever (hinged).....	1	...	All	...	6	11	
103-X-1	Nut, securing pedal pin to lever.....	1	...	All	...	9		
214-X-1	Washer, spring, for pedal pin nut.....	1	...	All	...	5		
147-X-1	Washer, plain, for pedal pin nut.....	1	...	All	...	5		

CHAINS

110046/65	Chain, front 65 links $\frac{1}{2}$ in. by .305 in.....	1	...	350	...	14	8	
110046/66	Chain, front 66 links $\frac{1}{2}$ in. by .305 in.....	1	...	500	...	14	10	

FRAME SECTION

FRAME

013916	Frame, rear portion only.....	1	...	All	...	6	10	0
STD-277	Stud, engine plate extension.....	1	...	All	...	6		
CF-147	Spacer, engine plate extension.....	1	...	All	...	8		
STD-4	Nut, engine plate extension stud.....	1	...	All	...	3		
010824	Bolt, uniting front and rear frames.....	1	...	All	...	6		
014483	Shield, for crankcase.....	1	...	All	...	6	3	
STD-277	Stud, engine plate clamping (36).....	1	...	All	...	6		
CF-147	Spacer, engine plate clamping stud (36).....	1	...	All	...	8		
STD-4	Nut, engine plate clamping stud (36).....	2	...	All	...	3		

NOTE 36. Not used if a dynamo is fitted

FRONT FORKS

41-G3L-FF184-T	Tube, cover, top (37).....	2	...	All	...	2	10	
----------------	-----	-----	-----	----------------------------	---	-----	-----	-----	---	----	--

NOTE 37. Not used when Dynamo is fitted

PROP STAND

011309	Stand, prop, bare.....	1	...	All	...	14	6	
--------	-----	-----	-----	------------------------	---	-----	-----	-----	----	---	--

PART NUMBER	DESCRIPTION	QTY.	USED ON	PRICE EACH	
				£	s. d.
FRONT MUDGUARD					
013947	Mudguard, front, bare.....	1	All	1	13 10
013928	Stay, front mudguard, front.....	1	All	11	2
013929	Stay, front mudguard, rear.....	1	All	11	10
012565	Bolt, front mudguard stay.....	8	All		3
STD-190	Washer, spring, front mudguard stay bolt.....	8	All		1
STD-143	Washer, plain, front mudguard stay bolt.....	8	All		1
STD-80	Nut, front mudguard stay bolt.....	8	All		1
41-G3L-M38	Bolt, front mudguard bridge.....	4	All		1
STD-192	Washer, spring, front mudguard bridge bolt.....	4	All		1
REAR MUDGUARD					
014220	Mudguard, rear, bare.....	1	All	2	12 10
013903	Stay, rear mudguard, front.....	1	All	11	9
013901	Stay, rear mudguard, rear.....	1	All	11	1
STD-343	Bolt, bottom, rear mudguard stay.....	2	All		4
STD-191	Washer, spring, stay bolt, bottom.....	2	All		1
STD-12	Washer, plain, stay bolt, bottom.....	2	All		1
STD-5	Nut, mudguard stay bolt, bottom.....	2	All		3
012565	Bolt, top, rear mudguard stay.....	8	All		3
STD-190	Washer, spring, stay bolt, top.....	8	All		1
STD-143	Washer, plain, stay bolt, top.....	8	All		1
STD-80	Nut, mudguard stay bolt, top.....	8	All		1
STD-345	Bolt, rear mudguard, top frame bridge.....	1	All		4
STD-346	Bolt, rear mudguard, bottom frame bridge.....	1	All		4
STD-5	Nut, mudguard, frame bridge, bolt.....	2	All		3
FRONT NUMBER PLATE					
011698	Plate, number, front.....	1	All	2	8
REAR NUMBER PLATE					
011533	Plate, number, rear.....	1	All	5	1
STD-70	Bolt, rear number plate.....	2	All		3
STD-12	Washer, plain, number plate bolt.....	4	All		1
STD-5	Nut, rear number plate bolt.....	2	All		3
STD-178	Spacer, rear number plate.....	1	All		1
FRONT CHAINCASE					
011312	Deflector, water, front chaincase.....	1	All	1	3
TOOL BOX					
STD-362	Bolt, fixing tool box to arch.....	1	All		4
STD-192	Washer, spring, box to arch bolt.....	1	All		1
STD-11	Washer, plain, box to arch bolt.....	1	All		1
STD-4	Nut, box to arch bolt.....	1	All		3
FOOT RESTS					
014380	Rod, footrest.....	1	All	2	3
STD-2	Nut, footrest rod.....	2	All		4
014484	Spacer, footrest rod, outside, right.....	1	All		8
011439	Arm, footrest.....	2	All	11	4
41-G3L-FR-25	Cap, end, footrest arm.....	2	All		8
STD-363	Bolt, fixing footrest arm cap.....	2	All		4
SADDLE					
014150	Saddle, with springs.....	1	All	3	1 8
013873	Saddle, less springs.....	1	All	2	11 8
014151	Spring, saddle.....	2	All	5	0
CONTROL CABLES					
41-C-2	Cable, clutch, complete.....	2	All	7	8
41-T-2	Cable, throttle complete.....	2	350	5	3
45-T-2	Cable, throttle, complete.....	2	500	5	3

The above are same as on Touring Models but a spare of each is secured to motor cycle available for instant use.

TANK SECTION.

PART NUMBER.		DESCRIPTION.	QTY.	USED ON.	PRICE EACH
OLD	NEW				

PETROL TANK FITTINGS

The bolts, and fittings on same, for the two front positions and the two rear positions are exactly the same as those detailed on page 35 for standard machines fitted with Air Cleaners.

OIL TANK

013925		Tank, oil, bare.....	1	All	1 17 6
--------	--	----------------------	---	-----	--------

OIL PIPES

014553		Pipe, oil feed.....	1	All	7 0
014551		Pipe, oil return.....	1	All	7 0

WHEEL AND BRAKE SECTION

PART NUMBER.		DESCRIPTION.	QTY.	USED ON.	PRICE EACH
OLD	NEW				

FRONT WHEEL

013609		Wheel, front, with all fittings.....	1	All	9 3 10
013627		Wheel, front, less all fittings.....	1	All	4 11 6
011694		Rim, wheel, front.....	1	All	1 3 7
38-18T-H51		Spoke, front wheel, long.....	20	All	4
012786		Spoke, front wheel, short.....	20	All	5
STD-143		Washer for spoke head (right side).....	20	All	1
013693		Tape only, front rim.....	1	All	1 0
011708		Bolt, security, front.....	1	All	4 0

REAR WHEEL

014877		Wheel, rear, with all fittings.....	1	All	6 19 10
014878		Wheel, rear, less all fittings.....	1	All	5 3 11
011693		Rim, rear wheel.....	1	All	1 4 9
36-2-H51		Spoke, rear wheel.....	40	All	6
012472		Nippie, rear wheel spoke.....	40	All	4
013690		Tape only, rear rim.....	1	All	1 0
011707		Bolt, security, rear.....	2	All	4 0

REAR WHEEL FITTINGS

014149		Spindle, centre, solid, rear wheel.....	1	All	5 7
STD-2		Nut, rear wheel spindle, left.....	1	All	4
12221		Nut, rear wheel spindle, right.....	1	All	9

ACCESSORIES

011907		Cable clip, 1½ in.....	6	All	2
011908		Cable clip, 3 in.....	5	All	2
011909		Cable clip, 4½ in.....	4	All	2

DETAILED INDEX

	Page		Page
Air Cleaner	15	Magneto	42
Axle, flywheel	7	Mudguards	27-47
Battery	42	Pipe, exhaust	12-45
Brakes, front and rear	41	Pipe, oil	37-48
Cable clips	43	Pipe, petrol	37
Cables, control	34-47	Piston	5-45
Carburetter	13-46	Plinger, oil pump	9
Carrier, battery	30	Re-boring	7
Carrier, rear	29	Regulator	42
Chains	17-46	Rests, foot, pillion	30
Chaincase	29-47	Rests, foot, rider's	30-47
Chainguard	29	Rockers	11
Clutch	22	Rod, connecting	7
Control levers	33	Rod, push	11
Crankcase	7	Saddle	31-47
Cylinder	5-45	Seat, pillion	31
Damper, fork	25	Shell, gear box	19
Dynamo	42	Silencer	12-45
Flywheel	7	Speedometer	44
Front fork	23-46	Sprockets	15-17-46
Frame	23-46	Stands	27-46
Gaskets	12-45	Steering Damper	25
Gears	19-46	Tank, oil	37-48
Grips, handlebar	31	Tank, petrol	35
Grips, knee	37	Timing gear	9
Guide, tappet	11	Tools	44
Guide, valve	5	Transfers	31
Handlebar	27	Valves, carburetter	15
Head, cylinder	5	Valves, engine	5
Horn	43	Valve, release	9
Kick-starter	22-46	Wheel, front	39-48
Lamp, head	43	Wheel, rear	39-48
Lamp, rear	43		