

&



FRAME - REAR
PARTS AND YEAR GUIDE

IDENTIFYING PARTS

12th September 2010

BY
John Ready

AJS & Matchless Restoration Guide

CONTENTS

1.1. ABBREVIATIONS	Error! Bookmark not defined.
1.2. DISCLAIMER	Error! Bookmark not defined.
1.3. COPYRIGHT STATEMENT	Error! Bookmark not defined.
1.4. Rear Frame	4
1.4.1. <i>Rigid Rear Ends</i>	4
1.4.2. <i>Spring Rear Ends</i>	10
2. WHEELS	ERROR! BOOKMARK NOT DEFINED.
2.1. Front Wheel	Error! Bookmark not defined.
2.1.1. <i>Front Hubs</i>	Error! Bookmark not defined.
2.2. Rear Wheel	Error! Bookmark not defined.
3. BRAKES	ERROR! BOOKMARK NOT DEFINED.
4. TANKS	ERROR! BOOKMARK NOT DEFINED.
4.1. Fuel Tanks	Error! Bookmark not defined.
4.2. Oil Tanks	Error! Bookmark not defined.
4.2.1. <i>1938</i>	Error! Bookmark not defined.
5. TOOL BOXES	ERROR! BOOKMARK NOT DEFINED.
6. ELECTRICAL	ERROR! BOOKMARK NOT DEFINED.
6.1. Brake Lights	Error! Bookmark not defined.

5.7. Introduction.

This guide is produced to allow the author to collate the information needed to identify parts that I continue to acquire. I hope that this information is of value to other collectors.

My interest is assembling bikes which are correct for the year and model. Whilst all the bikes are not necessarily “correct” I am always on the look out for the “correct” part. Like all addicts, I will never “be finished”.

All Chapters of this guide are “works in progress” and so will be updated as new information comes to hand and time allows. I invite others to provide additional information and corrections.

5.8. ABBREVIATIONS.

5.9. DISCLAIMER.

This Restoration Guide has been prepared solely for the use of John Ready. Use by any other party is completely at the risk of that party.

John Ready neither undertakes or accepts any liability in any way whatsoever to other any, in respect of the data herein contained including any errors or omissions however caused.

5.1. COPYRIGHT STATEMENT.

All rights reserved. The copyright of this Restoration Guide is the property of John Ready. Neither the Restoration Guide nor any part of it may be used or reproduced by any method whatsoever or incorporated by reference or in any manner whatsoever in any other document without the prior written consent of John Ready.

AJS & Matchless Restoration Guide

Many images are those of other people from the internet. Unfortunately I cannot acknowledge these parties as I do not know who they are. Most are from the various Spare Parts Manuals produced by A.J. Stevens, Matchless and later by AMC. My thanks to those whose images allow this guide to function.

As the copyright, if any, cannot be identified, this publication is not for commercial gain but is designed to assist AJS and Matchless fanatics to sort their parts and ease the sourcing of parts for particular models.

AJS & Matchless Restoration Guide

1. REAR FRAME

Frames over the years varied considerably with all sorts of layout tried, discarded, tried again and variations built by third party aftermarket suppliers.

Rigid frames were the most common until 1949 when “swing arm” rear suspension was introduced. An exception to this was a canter lever system was introduced in 1930 for the Silver Hawk and Silver Arrow.

The main areas of differences between models include:

- The number of tubes incorporated in the rear frame. Many had a triangular frame made up of two tubes but some models also included a third horizontal tube. Models such the 1936 AJS 500cc models and some Matchless models used this frame style;
- Distance between rear forks at the axle. This varies from approximately 7” spacing to approximately 8” in 1947;
- Rear lug – sidecar mounting lug, on many models after 1935 have this forged in the axle lug;
- Rear lug – pillion foot pegs, some models have the bolting directly onto the axle lug;
- Rear lug – rear stand, was introduced on some AJS and =M= models from 1937;
- Rear brake torque mounting bracket. Early models had a slotted bracket which was replaced with round holed bracket and the slot for the chain adjustment was incorporated in the backing plate. This change happened in 1941;
- Rear brake torque mounting bracket – matchless models until 1939 had this bracket on the right hand side frame rail as the brake drum was mounted on the opposite side of the rear wheel hub from the sprocket;
- Location of prop stand on the left hand frame rail adjacent to the engine. Early machines had the cast bracket behind the foot peg mounts, after 1949 they were mounted in front of the foot peg mount. There were also different types of brackets;
- Tool box mounting brackets. These varied in style and location and were generally on the right hand side of the rear frame until the introduction of the swing arm models in 1949. At this point there two tool boxes available which mounted inside the rear frame loop close to the top shock absorber mount;
- Seat mounts. Up until 1948 the mounting lugs for the saddle springs were horizontal but in 1948 the lugs were vertical castings so that the stud could be used to adjust the height of the springs.
- Voltage regulator mounting brackets.

1949 was a watershed year with the introduction of swing-arm suspension for the rear, the introduction of the 500cc “Spring Twin” vertical 2 cylinder engine to supplement the singles. Also included in this year was a change to the layout of the rigid rear ends.

1.7.1. RIGID REAR ENDS

This saw the lug for the side stand moved from behind the foot peg to in front of the foot peg

Year	Common Part No.	Description (Common)	Brand	Model
1938	38-8-F24	Frame, rear portion only, bare	AJS	9
1939	39-12-F24	Frame, rear portion only, bare	AJS	12 12M 16

AJS & Matchless Restoration Guide

Year	Common Part No.	Description (Common)	Brand	Model 16M 22 22SS 22T 26 26SS 26T
	39-8-F24	Frame, rear portion only, bare	AJS	8 9 18 18SS 18T
1941	41-G3L-F24	Frame, rear portion only, bare	=M=	G3L
1946	41-G3L-F24	Frame, rear portion only, bare	AJS	18 16M
1947	41-G3L-F24	Frame, rear portion only, bare	=M=	G3L G80
			AJS	18 16M
1948	012890	Frame, rear portion only, bare	AJS	18 16M
1949	013773	Frame, rear portion only, bare	AJS	18 16M 16MC 18LC
1950	015106	Frame, rear portion only, bare	AJS	18 16M
	015146	Frame, rear portion only, bare	AJS	16MC 18C
1951	015583	Frame, rear portion only, bare	AJS	18 16M
	015788	Frame, rear portion only, bare	AJS	16MC 18C
1952	015583	Frame, rear portion only, bare	AJS	18 16M
	015788	Frame, rear portion only, bare	AJS	16MC 18C
1953	015583	Frame, rear portion only, bare	AJS	18 16M
	015788	Frame, rear portion only, bare	AJS	16MC 18C
1955	021049	Frame, rear portion only, bare	AJS	18 16M
	021050	Frame, rear portion only, bare	AJS	16MC 18C

Detail Point	Location	Year	Make	Model
Rear Frame				
Width of frame at axle mount				
3 spar rear end				
2 spar rear end				

AJS & Matchless Restoration Guide

Detail Point	Location	Year	Make	Model
Forged rear axle fork bracket				
Width of axle slot				
Rear stand mount included				
Slotted rear brake anchor	RH Side		Matchless	
		1936 onwards	Matchless	
	LH Side	1935	Matchless	

1934 – 193?

MATCHLESS

Main points;

- No sidecar mounts;
- Slotted bracket for rear brake torque mount – on RH side rail;
- Mounts for tool box on RH bottom rear rail;
- Tube mount for rear saddle springs;
- No sidecar lug in rear axle fork forging;
- No rear stand mount.

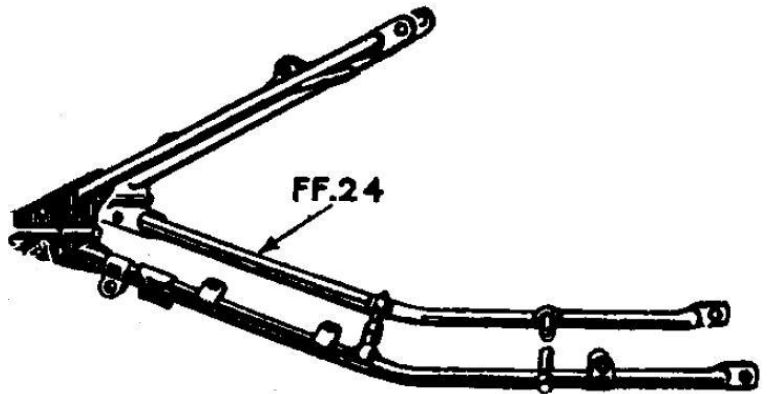

1935 – 193?

AJS

Main points:

- No rear stand mount;
- Horizontal lugs on saddle spring mounts;
- No side stand mount;
- Slotted bracket for rear brake torque mount – on LH side rail;
- Pillion footpegs bolt to frame at rear flange.

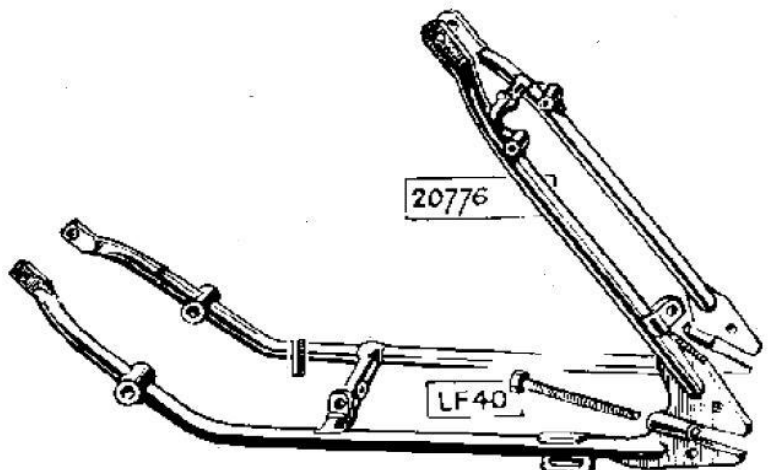

AJS & Matchless Restoration Guide

1937 –

AJS 37/2, and 37/2A

Main points:

- Rear stand mount;
- Horizontal lugs on saddle spring mounts;
- Short top tubes;
- Slotted bracket for rear brake torque mount – on LH side rail;
- Pillion footpegs bolt to frame at rear flange.
- Two cast brackets near rear wheel on top tube;
- No regulator brackets.

AJS 37/12, 37/22, 37/16 and 37/26

Main points:

- No rear stand mount;
- Horizontal lugs on saddle spring mounts;
- No side stand mount;
- Slotted bracket for rear brake torque mount – on LH side rail;
- Pillion footpegs bolt to frame at rear flange.
- Leather tool box mounted above lower rear frame rail;
- No regulator brackets.

AJS 37/8, 37/18, and 37/9

Main points:

- No rear stand mount;
- Horizontal lugs on saddle spring mounts;
- No side stand mount;
- Slotted bracket for rear brake torque mount – on LH side rail;
- Pillion footpegs bolt to frame at rear flange.

AJS 37/22T, 37/26T and 37/18T

Main points:

- Rear stand mount;
- Horizontal lugs on saddle spring mounts;
- No side stand mount;
- Slotted bracket for rear brake torque mount – on LH side rail;
- Pillion footpegs bolt to frame at rear flange.

AJS & Matchless Restoration Guide

1941 – 1947

- ½" Slot for rear axle;
- No sidecar mounts;
- Solid bracket for rear brake torque mount – on LH side rail;
- Mounts for tool box on RH side, bottom of top rear rail;
- Short horizontal tube mount for rear saddle springs;
- Mounts for regulator on crossbar for mudguard mount, below seat
- No sidecar lug in rear axle fork forging;
- Rear stand mount;
- Side stand mount bracket behind foot peg mount brackets;
- Pillion foot pegs have special brackets on bottom rails just forward of rear axle fork forging.

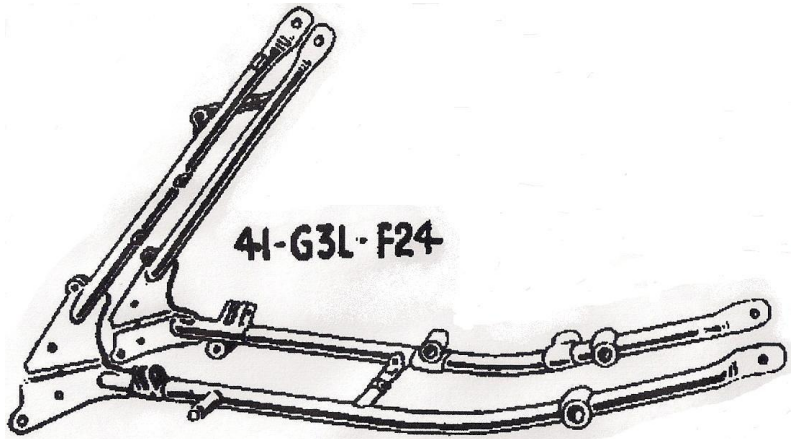

1948

- ½ Slot for rear axle;
- No sidecar mounts;
- Solid bracket for rear brake torque mount – on LH side rail;
- Mounts for tool box on RH side, top of top rear rail;
- Vertical tube / stud mount for rear saddle springs;
- No sidecar lug in rear axle fork forging;
- Rear stand mount;
- Side stand mount bracket behind foot peg mount brackets;
- Pillion footpegs have special brackets on bottom rails just forward of rear axle fork forging.

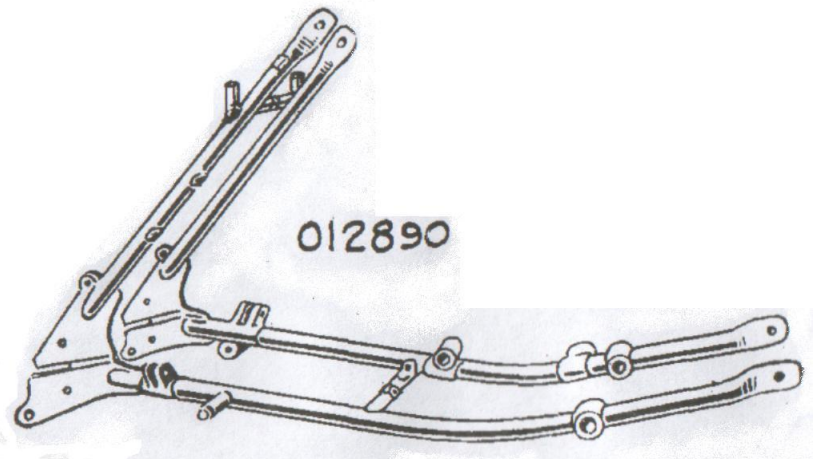

1949

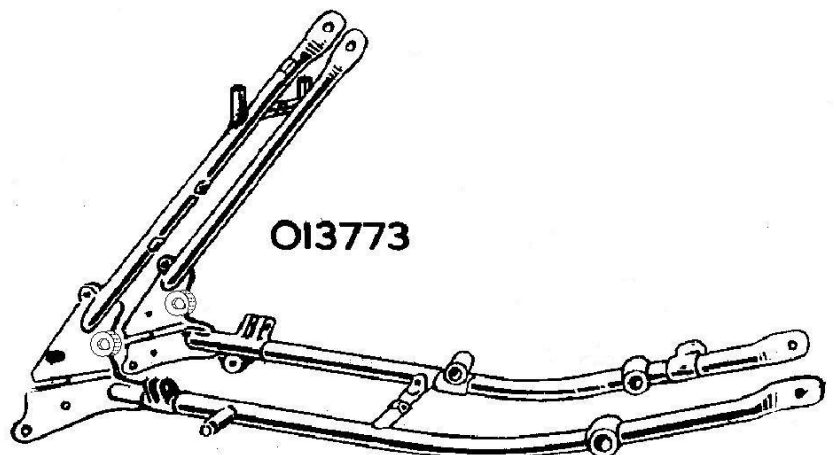

AJS & Matchless Restoration Guide

1950

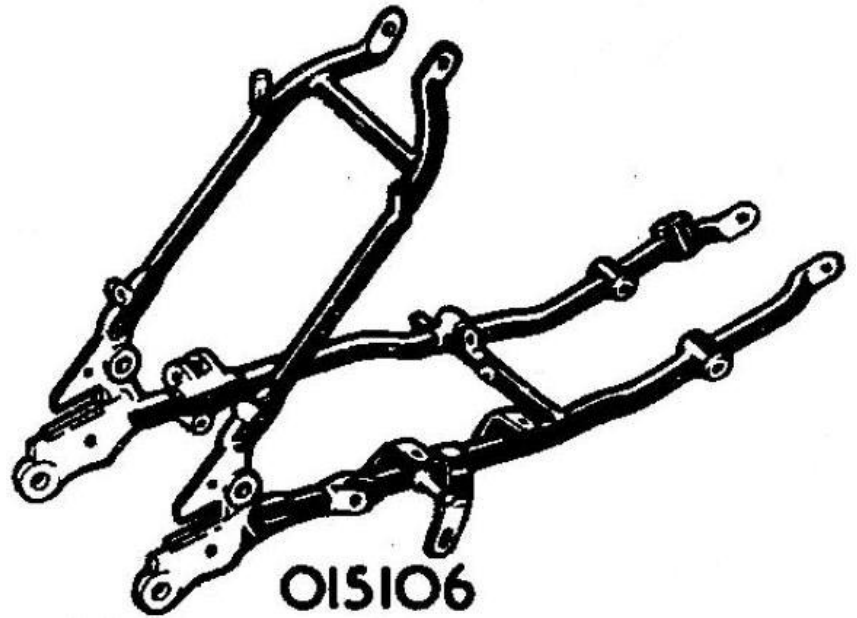

1951 - 1953

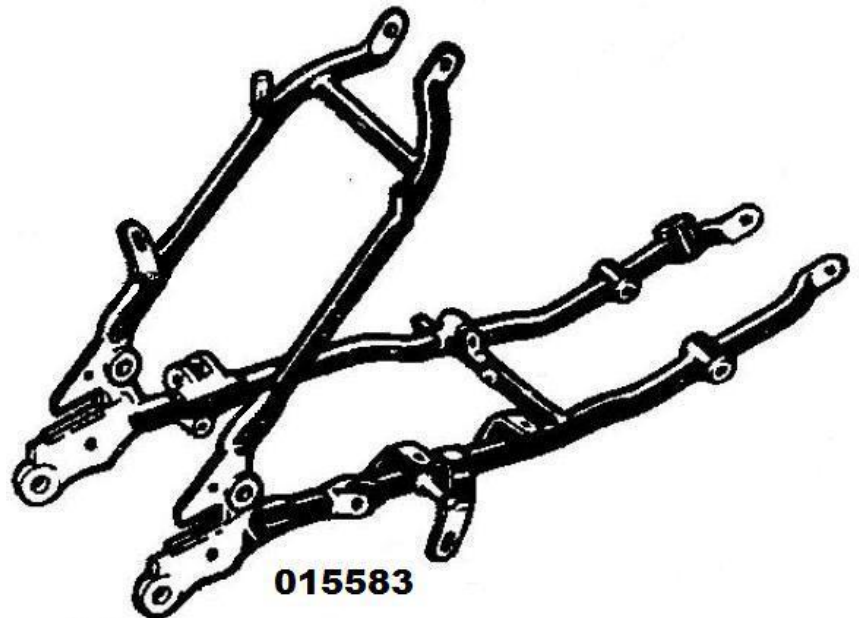

AJS & Matchless Restoration Guide

1954 - 1955

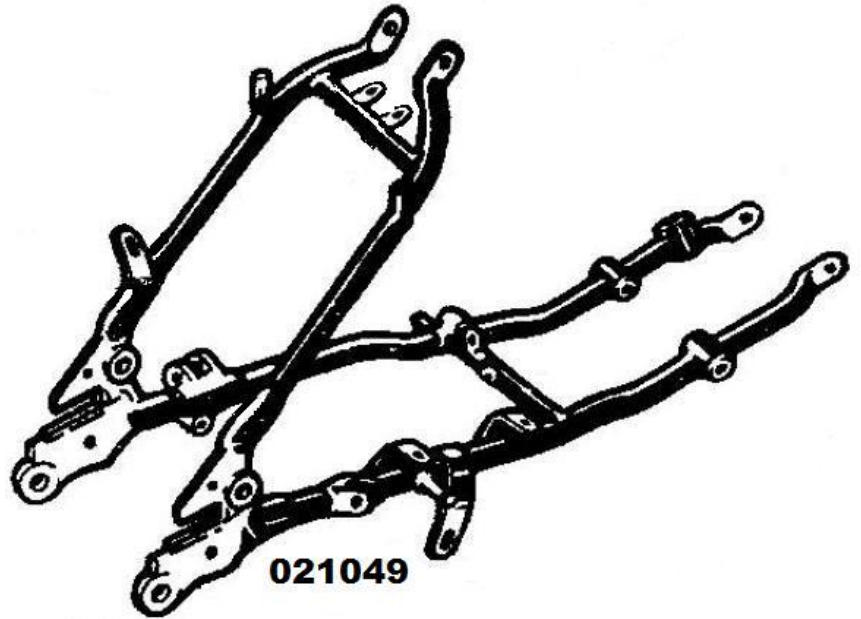

1.7.2. SPRING REAR ENDS
1949 - 1952

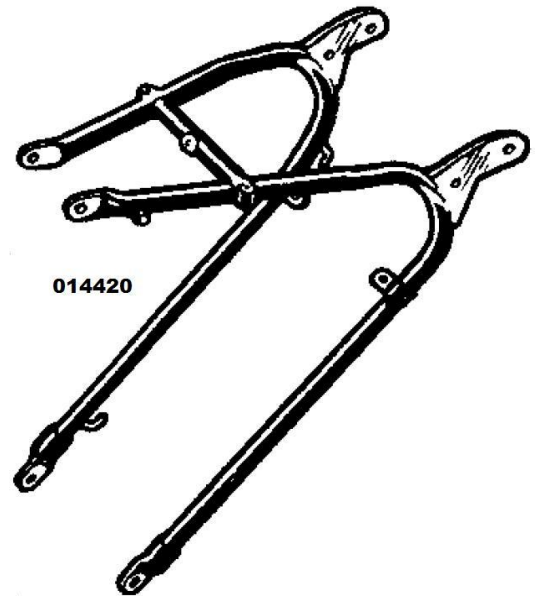

1953

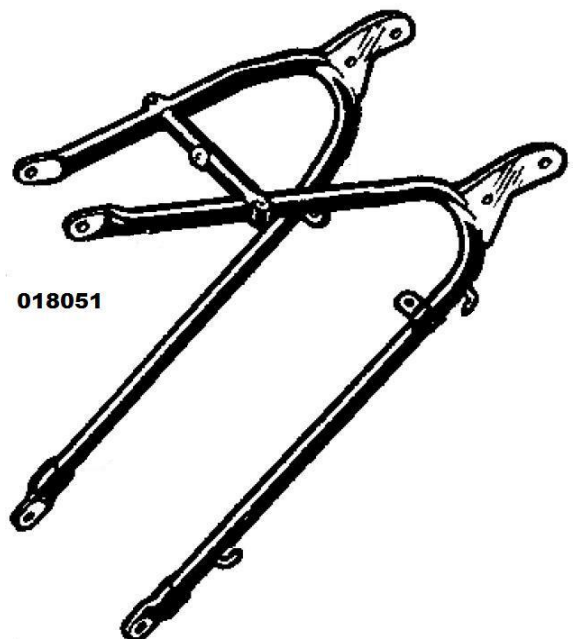

AJS & Matchless Restoration Guide

1954

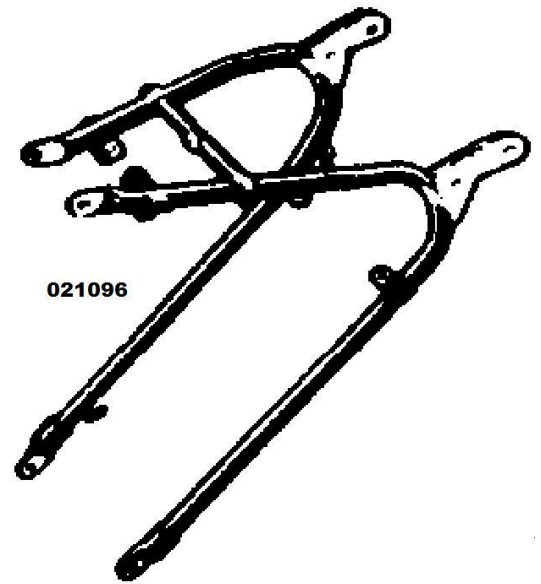

1955 – 195?

