

All about

CARBURETTORS

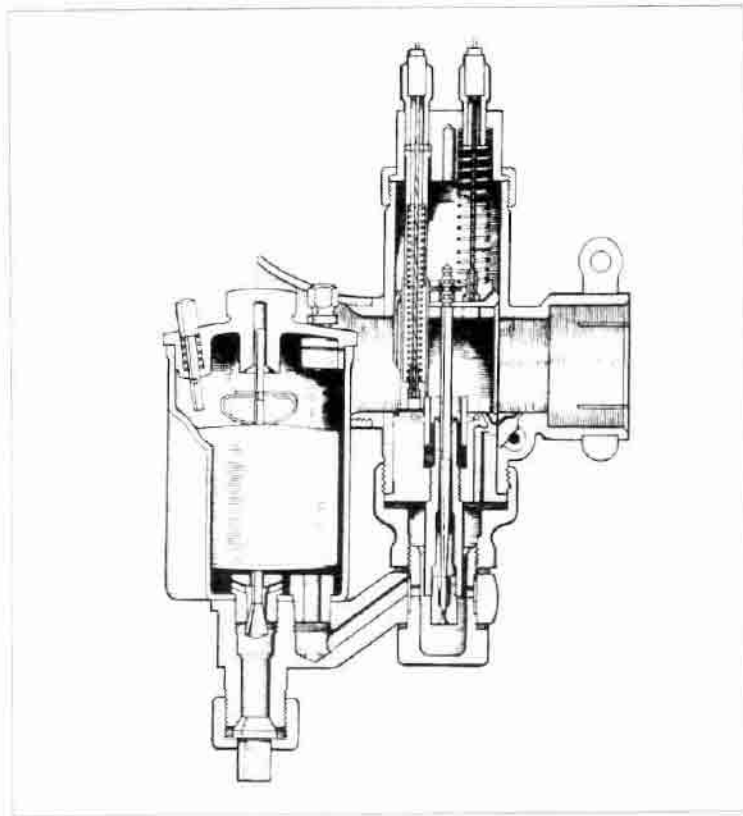

THE CLASSIC
MotorCycle

AMAL CARBURETTORS



mal carburetors are straightforward, workmanlike instruments

which can be readily adjusted to obtain fuel economy. Instructions for tuning the Type 276 also apply to the later Monobloc and Concentric. The basic difference between these three designs is the position of the float-chamber.

In normal circumstances it will be found that the best all-round settings for performance are those recommended by the manufacturers of a machine, with the idling individually adjusted to suit a particular engine by means of the pilot air screw and the throttle stop screw.

MIXTURE STRENGTH

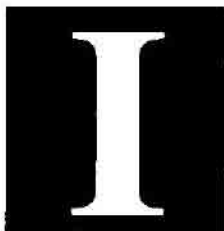

It is important to remember the influence that each variable has on

the mixture. If one has constantly in mind that (a) the

pilot air screw controls the mixture up to $\frac{1}{8}$ throttle opening, (b) the throttle cutaway from $\frac{1}{8}$ to $\frac{1}{4}$, (c) the throttle needle from $\frac{1}{4}$ to $\frac{3}{4}$, and (d) the main jet from $\frac{3}{4}$ to full throttle, the effect of changes from standard settings can be anticipated fairly accurately. Further, it is a simple matter to decide where to start in altering carburettor settings.

To take an extreme case for example, it is a waste of time fitting a smaller main jet if economy at 30 mph is required. At that speed, the throttle is less than a quarter open and the major influence on mixture strength comes from the throttle cutaway. It should not be inferred from the Amal instructions that mixture control by pilot air screw, throttle, valve cutaway, throttle needle position and main jet takes place in absolutely clear-cut stages. It does not. There is a certain amount of overlap, and it will be found, for instance, that an over-rich pilot air screw setting will cause a measure of heavy

fuel consumption though the machine may be driven for long periods on half throttle. However, these stages of mixture control are the key to the methods used in tuning.

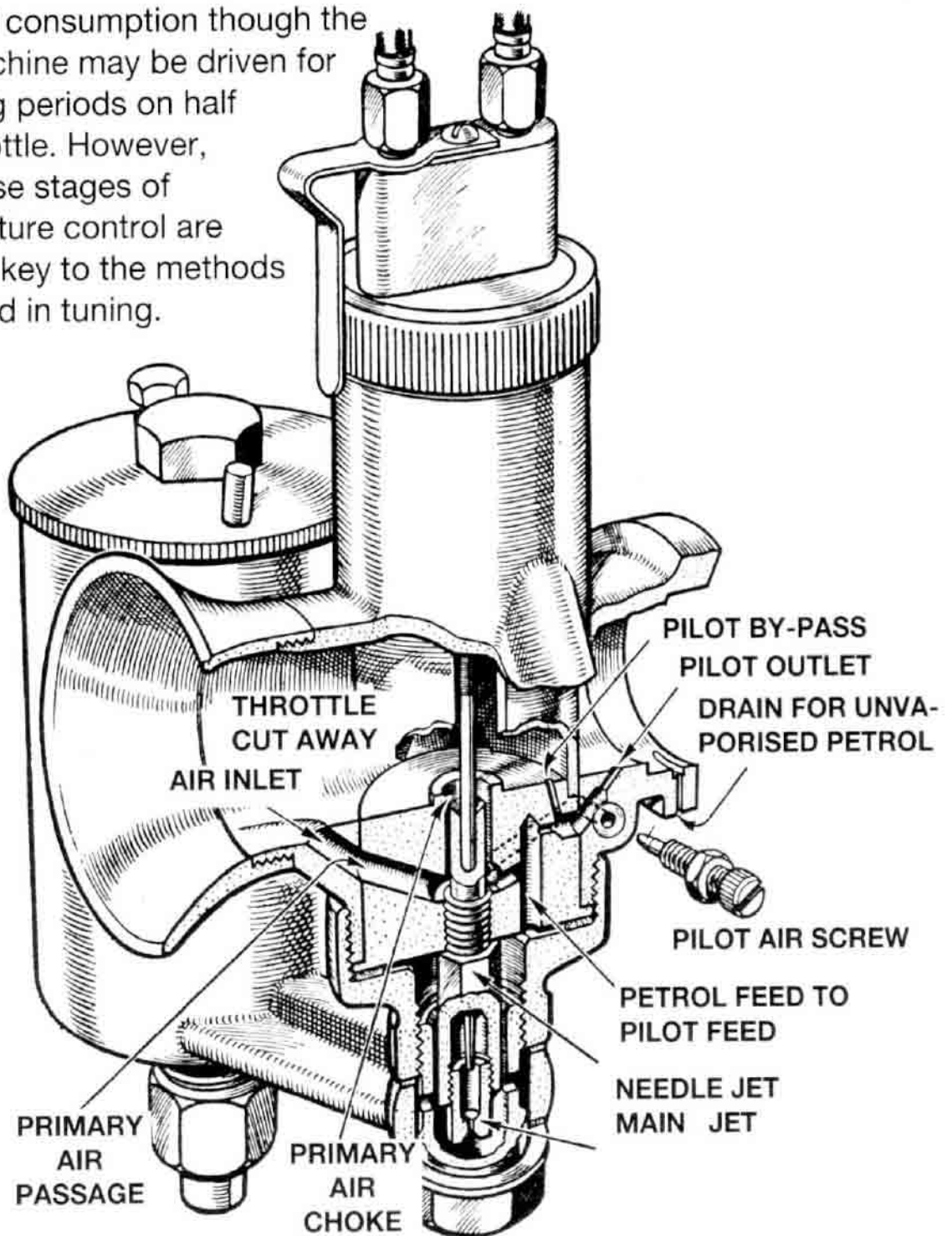

Amal Type 276 was a pre-war design with separate float chamber. The main jet screws into the bottom of the needle jet. It is calibrated to indicate the number of cubic centimetres of petrol that will flow through the orifice under given conditions in one minute; a jet stamped with the number 140 will pass 140cc, and it follows that the smaller the number the smaller the jet and vice versa.

SATISFACTORY IDLING

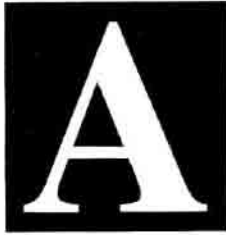

t its business end the pilot air screw is tapered.

Turning the screw clockwise brings the taper closer into the air orifice and gives a richer slow-running mixture; turning the screw in the other direction weakens the mixture, of course. When making this adjustment the best results are achieved by coordinating the throttle stop setting. The only point to watch is that there is enough slack in the cable to allow the throttle valve to seat on the head of the stop screw. Further, it must be remembered that satisfactory idling will never be obtained if there are air leaks between the carburettor and the combustion chamber or if there are ignition faults. Once the desired tickover has been obtained the slack in the cable can be taken up by means of the adjuster in the outer casing or at the top of the carburettor.

Throttle valves are identified by marking such as 6/5, 5/5

SEQUENCE OF TUNING

UP TO $\frac{1}{8}$
OPEN PILOT
AIR SCREW

$\frac{1}{8}$ TO $\frac{1}{4}$ OPEN
THROTTLE
CUT-AWAY

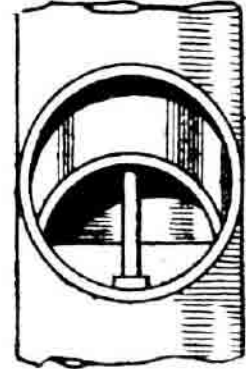
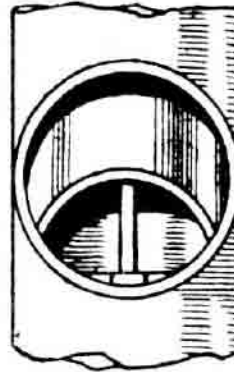

2nd & 5th

3rd

$\frac{1}{4}$ TO $\frac{3}{4}$ OPEN
NEEDLE
POSITION

$\frac{3}{4}$ TO FULL
OPEN MAIN
JET SIZE

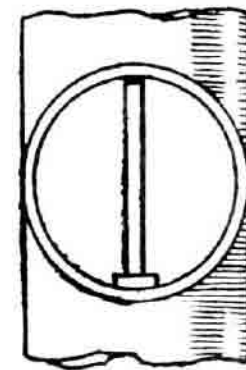
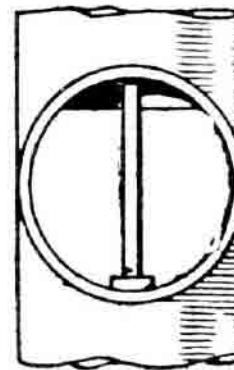

4th

1st

and so on. The first figure identifies the type of valve with its type of carburettor. The second figure gives the depth of the cutaway in $\frac{1}{16}$ ths of an inch; thus a 6/5 valve has a $\frac{6}{16}$ in cutaway, and a 6/4 valve has a $\frac{4}{16}$ in cutaway. The

deeper the cutaway the weaker will be the mixture.

WEAKER OR RICHER?

The final adjustment in the sequence is that of the throttle needle position. Needles are tapered and have five notches at the top end. The needle operates in the needle jet through which the fuel passes up into

the mixing chamber. A spring clip located in the notch selected attaches the needle to the throttle valve and the needle thus moves up and down with the throttle. Putting the clip in a notch nearer the top of the needle lowers the needle relative to the throttle and results in a weaker mixture; raising the needle has, of course, the reverse effect.

PILOT MIXTURE SUPPLY HOLE BETWEEN THROTTLE AND ENGINE

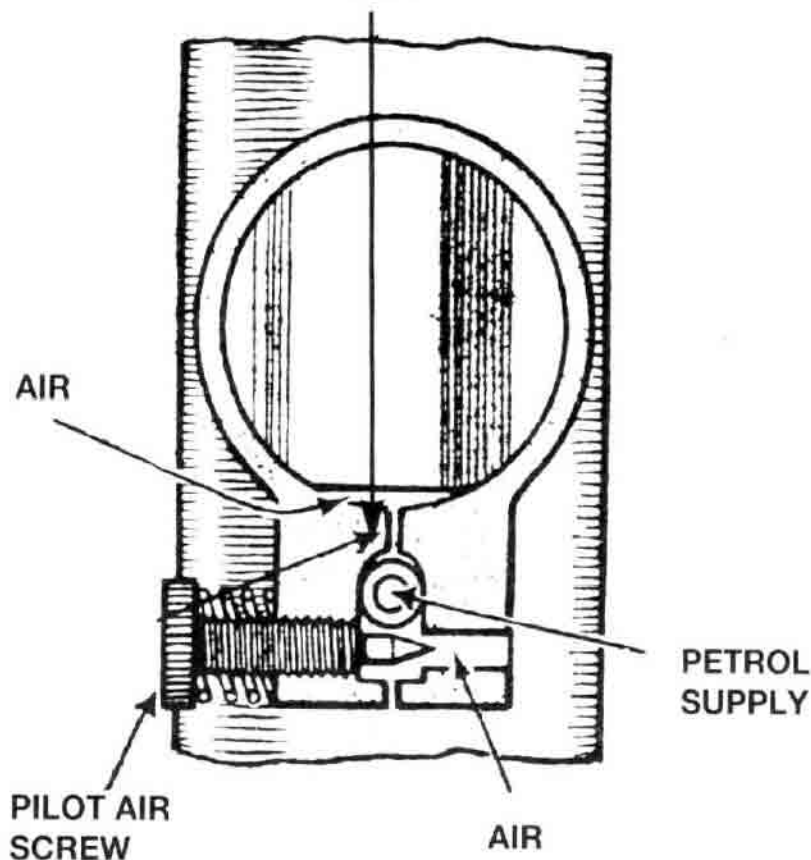

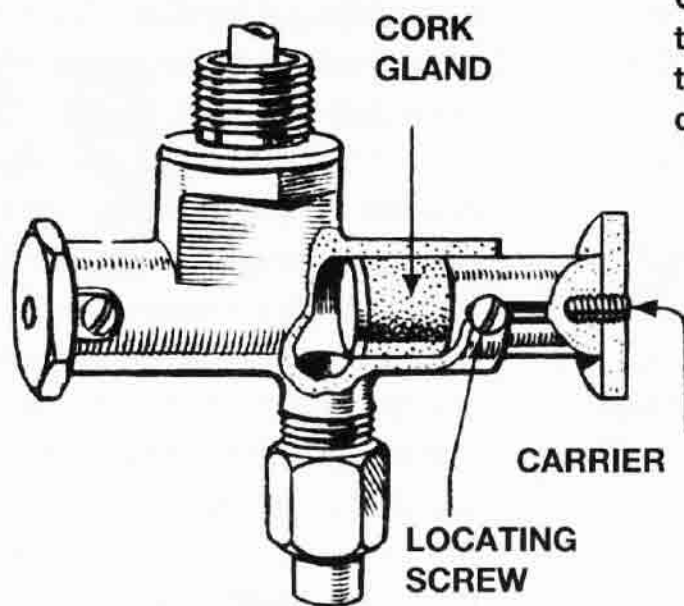

On some Ewarts taps the carrier is adjustable to compensate for wear on the gland.

LEAKING PETROL TAP

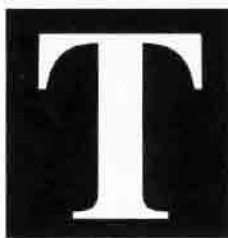

he Ewarts reserve tap is common to many machines and it relies on cork glands to prevent petrol leakage along the plungers. Each plunger is screwed into a carrier for the cork gland. The carrier is tightened to shorten the length of the gland and thus expand its diameter and make it a tighter fit in the tap body. Usually a turn or so of the carrier (when the plunger is withdrawn by slackening off the locating screw) will remedy a leak, but there is a limit to the range of adjustment. If necessary new cork glands can be obtained.

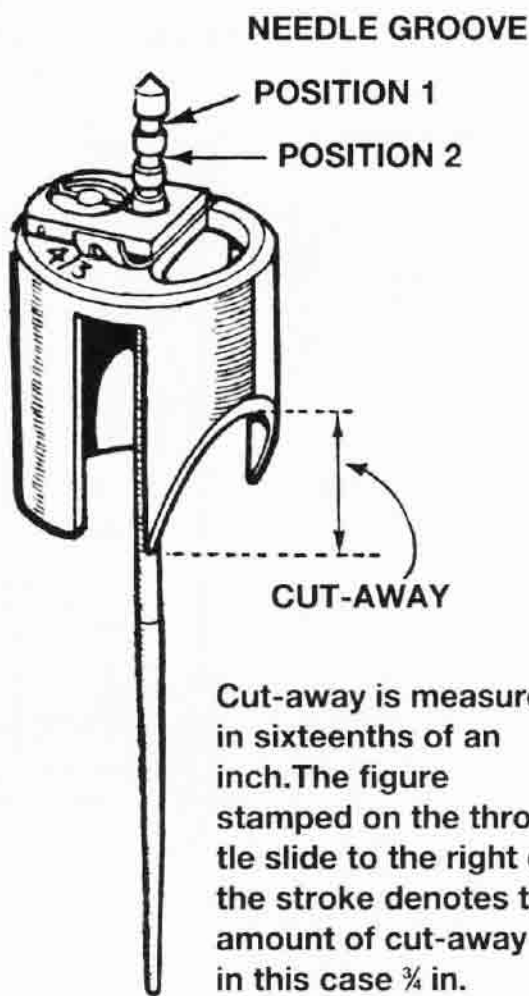

Cut-away is measured in sixteenths of an inch. The figure stamped on the throttle slide to the right of the stroke denotes the amount of cut-away — in this case $\frac{3}{4}$ in.

This drawing of the Amal Monobloc carburettor, introduced in 1955, clearly indicates the constructional features. The main and needle jets screw into the ends of the jet holder, the pilot jet is detachable and the throttle slide is guided internally on the jet block.

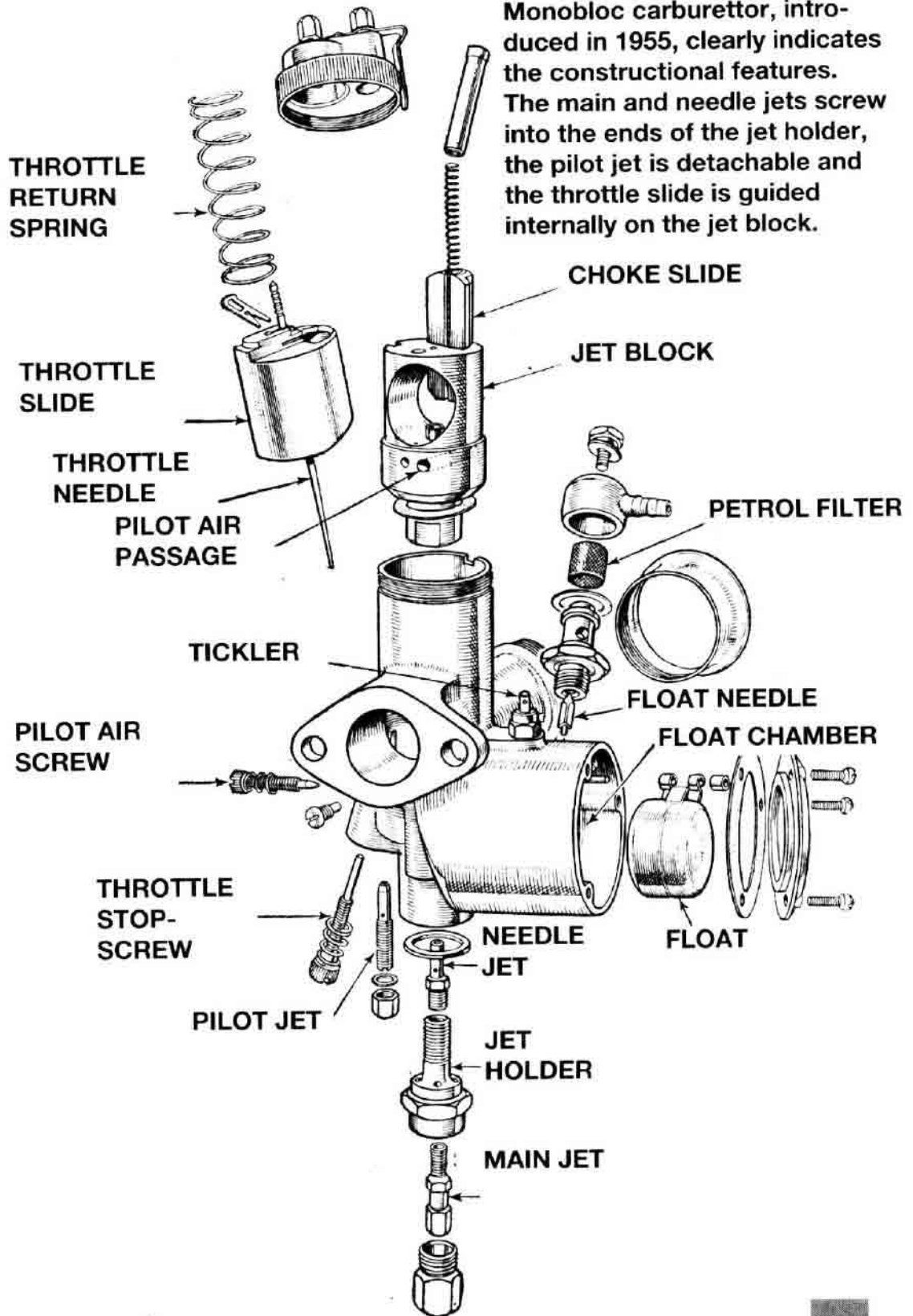

AMAL HINTS & TIPS

Starting from cold. Flood the carburettor by depressing the tickler sharply three or four times, and close the air valve: set the ignition say half retarded. Then shut the throttle and open it a little, about one-eighth open, then kickstart. If it is too much open starting will be difficult.

Starting, engine hot. Do not flood the carburettor but close the air lever. Set the ignition and close the throttle, then open the throttle about one-eighth of its travel and kickstart. If the carburettor has been flooded and won't start because the mixture is too rich — open the throttle wide and give the engine several turns to clear the richness, then start again with the throttle one-eighth open, and air lever wide open. Generally speaking it is not advisable to flood at all when an engine is hot.

Starting, general. By experiment, find out if and when it is necessary to flood, also note the best position for the air lever and the throttle for the easiest starting (some carburettors have the throttle stop fitted with a starting position on to which the throttle must be shut down).

Starting, single lever carburettors. Open the throttle very slightly from the idling position and flood the carburettor more or less according to the engine being cold or hot .

• **Cable controls.** See that there is a minimum of backlash when the controls are set back and that any movement of the handlebar does not cause the throttle to open; this is done by the adjusters on the top of the carburettor. See that the throttle shuts down freely.

• **Petrol feed, verification.** Detach petrol pipe union at the float chamber end; turn on petrol tap momentarily and see that fuel gushes out. Avoid petrol pipes with vertical loops as they cause air locks. Flooding may be due to a worn or bent needle or a leaky float, but nearly all flooding with newly restored machines is due to impurities (grit, fluff, etc.) in the tank — so clean out the float chamber periodically until the trouble ceases. If the trouble persists, the tank may be sealed with a chemical sealer. Note that if a carburettor, either vertical or horizontal, is flooding with the engine stopped, the overflow from the main jet will not run into the engine but out of the carburettor through a hole at the base of the mixing chamber.

• **Fixing air leaks.** Erratic slow running is often caused by air leaks, so verify there are none at the point of attachment to the cylinder or inlet pipe — check by squirting oil on to the suspect joint. If the engine smoothes out, eliminate by new washers and the equal tightening up of the flange nuts. In old

machines look out for air leaks caused by a worn throttle slide and carburettor body or worn inlet valve guides.

Banging in exhaust may be caused by too weak a pilot mixture when the throttle is closed or nearly closed — also it may be caused by too rich a pilot mixture and an air leak in the exhaust system; the reason in either case is that the mixture has not fired in the cylinder and has fired in the hot silencer. If the banging happens when the throttle is fairly wide open the trouble will be ignition — not carburation.

Bad petrol consumption may be due to flooding, caused by impurities from the petrol tank lodging on the float needle seat and so preventing its valve from closing. If the machine has had several years' use, flooding may be caused by a worn float needle valve.

Also bad petrol consumption will be apparent if the throttle needle jet has worn; it may be remedied or improved by lowering the needle in the throttle, but if it cannot be — then the only remedy is to get a new needle jet.

Air filters. These may affect the jet setting, so if one is fitted afterwards to the carburettor the main jet may have to be smaller. If a carburettor is set with an air filter and the engine is run without it, take care

not to overheat the engine due to too weak a mixture; testing with the air valve will indicate if a larger main jet and higher needle position are required.

HOW TO TRACE FAULTS

There are only two possible faults in carburation, either richness of mixture or weakness of mixture, so in case of trouble decide which is the cause, by:-

1. Examining the petrol feed.

Verify jets and passages are clear. Verify ample flow. Verify there is no flooding.

2. Looking for air leaks.

At the connection between carburettor and engine. Or due to leaky inlet valve stems.

3. Defective or worn parts.

Slack throttle.
Worn needle jet.
The mixing chamber union nut not tightened up on type 276, or loose jets.

4. Testing with the choke slide

to see if by richening the mixture, the results are better or worse.

INDICATIONS OF

Richness

Black smoke in exhaust
Petrol spraying out of carb
Four-strokes, eight-stroking
Two-strokes, four-stroking
Heavy, lumpy running
Heavy petrol consumption
? If the jet block is not
tightened up by washer and
nut, richness will be caused
through leakage of petrol
? Air-cleaner choked up
? Needle jet worn large
? Sparking plug sooty

Weakness

• Spitting in carburettor
• Erratic slow running
• Overheating
• Acceleration poor
• Engine goes better if:-
• Throttle not wide open or
• choke is partially closed
• ? Has air cleaner been
• removed
• ? Jets partially choked up
• *Removing the silencer or*
• *running with a racing silencer*
• *requires a richer setting and*
• *larger main jet.*

Note: Verify correctness of fuel feed, stop air leaks, check over ignition and valve operation and timing. Decide by test whether richness or weakness is the trouble and at what throttle position.

PROCEDURE

If at a particular throttle opening you partially close the choke and the engine goes better, weakness is indicated; if the running is worse, richness is indicated.

To cure richness

1st Fit smaller main jet
2nd Screw out pilot air screw
3rd Fit a throttle slide with
larger cut-away
4th Lower needle one or two
grooves

To cure weakness

• **1st** Fit larger main jet
• **2nd** Screw pilot air screw in
• **3rd** Fit a throttle slide with
smaller cut-away
• **4th** Raise needle one or two
grooves

Note: It is not correct to cure a rich mixture at half throttle by fitting a smaller main jet because the main jet may be correct for power at full throttle; the proper thing to do is to lower the needle.

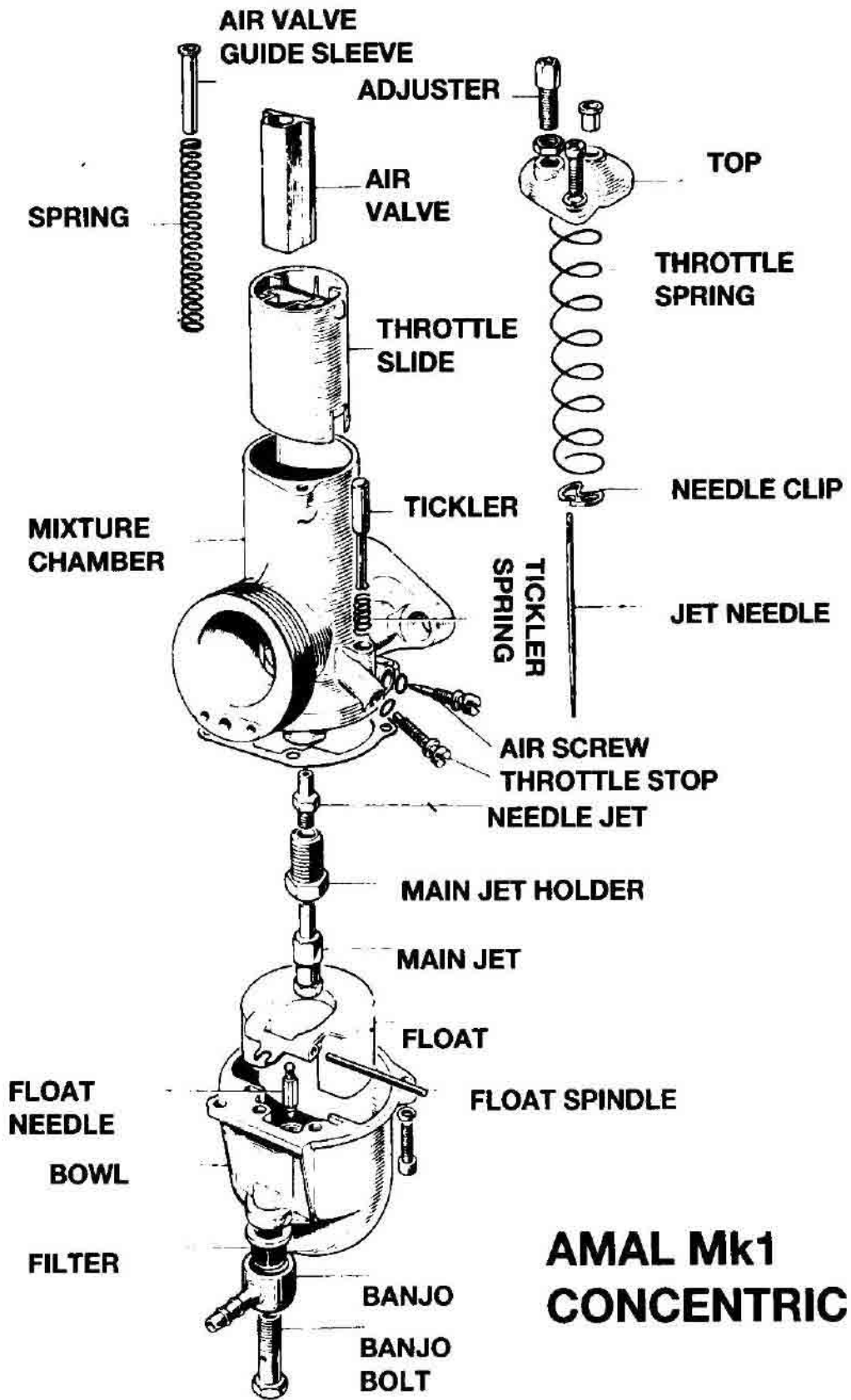

AMAL Mk1 CONCENTRIC

TUNING TWIN ENGINES WITH TWIN CARBURETTORS

F

irst of all, slacken the throttle stop screw valves and put the twistgrip into the shut off position to allow the throttle to shut off; there should be a slight backlash in the cables which can be obtained, if necessary, by screwing in the cable adjusting screws on the top of the carburettor. Then, with the handlebars in the normal position, and with the throttles closed, adjust the cable adjusting screws so that on the slightest opening of the twistgrip, both throttle valves begin to open simultaneously.

Main jet sizes are selected by checking the effect of the mixture on the sparking plugs after taking a run at full throttle over a straight piece of road; the smallest pair of jets that give the best maximum speed is usually correct provided that the plugs do not show any signs of excessive heat. It might be

that for really critical tuning, one carburettor might require a slightly different jet size from the other.

For slow running, set the twistgrip to make the engine run slowly but just faster than at tickover; then gently screw in the throttle stops to just hold the valves in that position, and return the twistgrip into the shut position, leaving the engine running on the throttle stops.

The next thing to do is to set each carburettor to obtain the idling by screwing down the throttle stop screws and adjusting the pilot air screws accordingly.

Regarding the setting of the pilot jets, a fairly satisfactory method is to detach one sparking plug lead, and set the pilot air adjusting screw on the other cylinder as a single unit, reversing the process for the other cylinder. It may be found that when both leads are connected to the sparking plugs, the engine runs slightly quicker than desirable, in which case, a slight readjustment of the throttle

stop screws will put this right. It is essential that the speed of idling on both cylinders is approximately the same, as this will either make or mar the smoothness of the get-away on the initial opening of the throttle.

It is essential with twin carburetors that the throttle slides are a good fit in the bodies, and also that there is no suspicion of air leaks at either of the flange attachments to the cylinder.

Regarding the lower end of the throttle range, which is always the more difficult to set, one can only take excessive pains to make quite sure that the control cables are perfectly adjusted, without any excessive backlash or difference in the amount of backlash between one carburetor and another; otherwise one throttle slide will be out of phase with the other, and so resulting in lumpy running.

To check the opening of the throttles simultaneously, shut the twistgrip back so that the throttles are resting on the throttle stop screws in their

final position of adjustment; then insert the fingers into the air intakes and press them on the throttles and with the other hand, gently open by the twistgrip and feel that the throttles lift off their stops at the same time.

VILLIERS CARBURETTORS



Villiers carburetors resemble Amal instruments in that they embody a

throttle slide and variable needle jet and operate on a multiphase principle.

However, Villiers employed an annular float surrounding the centre-piece or jet holder. The Junior carburetor fitted to 98cc engines is of simpler design than the larger types. Its main jet is simply a hole in the wall of the centre-piece and so cannot be varied, whereas on the remaining models it is separate and, except in the case of the S22, screws into the center-piece. The S22 — fitted to the 249cc twin and the 173cc 2L — has its jet in the bottom of the float bowl.

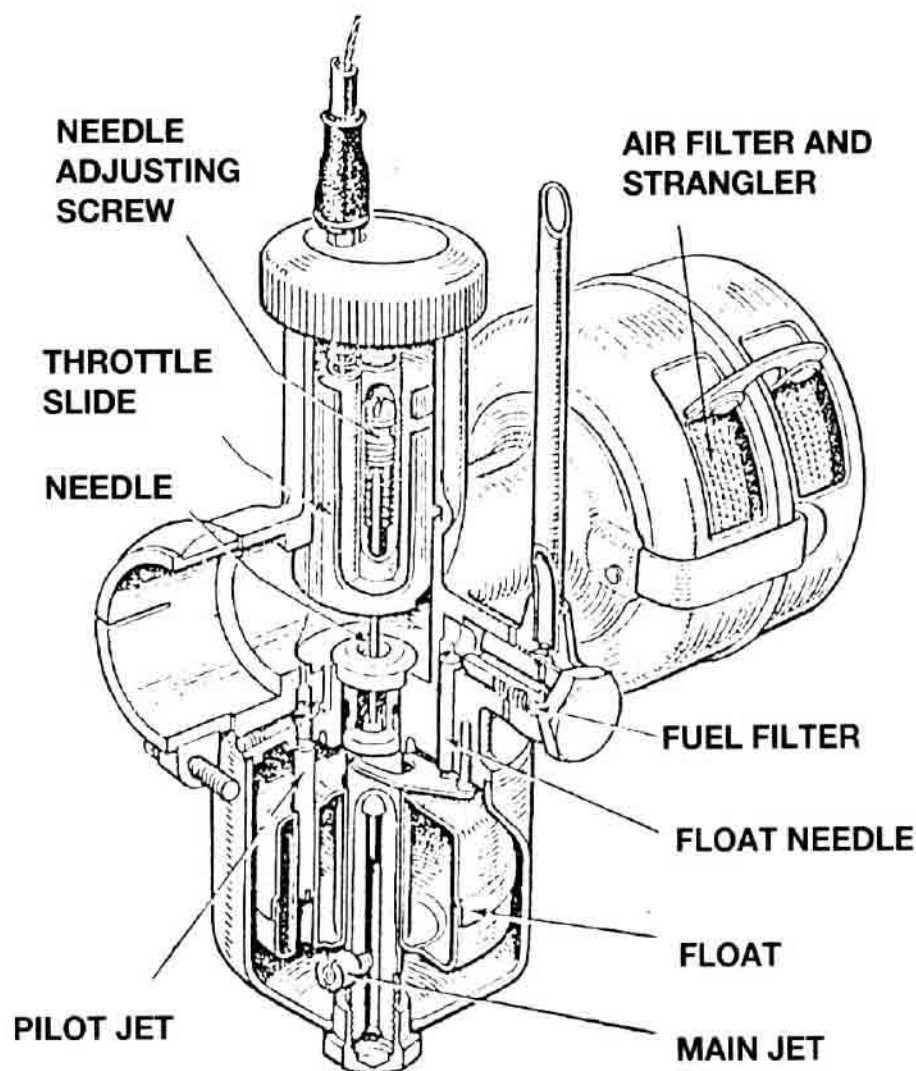

A typical Villiers carburettor is the S25 fitted to 8E, 9E, 1H and 2H engines as well as the earlier 29C. Disposition of float, jets and strangler is clearly visible.

Different main jets are available for the larger carburettors but nothing will be gained by fitting a smaller size unless the mixture is appreciably rich above three-quarter throttle — indicated by a tendency to four-

• stroking.

• On the Junior and on all
 • pre-1954 carburettors there
 • is no separate pilot system;
 • the slow-running supply is
 • drawn from the needle jet.
 • S19, 22 and 25 models have
 • a pilot jet which projects

downward from the body into the float chamber. The air metering screw, on the right of the carburettor, is turned counter-clockwise to weaken the mixture; it should be screwed out $\frac{1}{8}$ turn at a time when adjusting, as far as is compatible with good starting and idling.

The throttle slide governs the mixture strength from $\frac{1}{8}$ to $\frac{3}{4}$ throttle and has a cut-away lower edge on the intake side. Cutaway height is stamped on the slide, the units being sixteenths of an inch. Experience indicates that, in general, a greater cutaway than standard as decided by the manufacturers is not practicable.

On all carburettors except the S22, the taper needle (which controls the mixture from $\frac{1}{4}$ to $\frac{3}{4}$ throttle) is held up by a light spring against an adjusting screw in the throttle slide. Clockwise rotation of the screw lowers the needle and so weakens the mixture. The thread has 32 tpi, so that one turn moves the needle $\frac{1}{32}$ in. Weakening can be taken as far as is possible without a

marked adverse effect on the performance, but a quarter-turn at a time is the maximum recommended.

A five-groove needle with wire-clip location is a feature of the S22 carburettor; the usual setting has the clip in the fourth groove from the top. Because of the intervals between the grooves it is unlikely that a weaker setting than normal will be found practicable.

Some earlier carburettors are of the two-lever pattern on which the needle is raised by a second handlebar control to richen the mixture for starting. This scheme was superseded by an air slide or a shutter-type strangler embodied in the air filter.

A final word of warning: with petroil lubrication, a weaker mixture means less oil drawn into the engine. It is unlikely that the engine will run satisfactorily on a mixture lean enough to affect lubrication but, if in doubt, increase the oil content in the petroil mixture slightly — from the standard 1 in 20 to, say, 1 in 16.

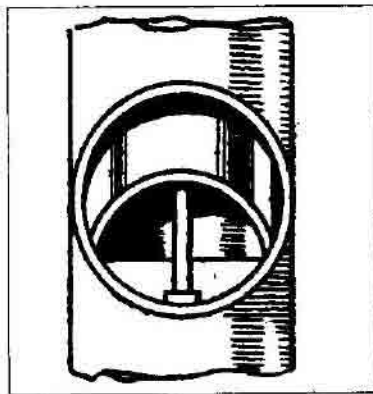

This booklet is presented free with

**THE CLASSIC
Motorcycle**