

Do not take the Throttle Stop Screw out completely.

Failure to secure good "idling" will probably be traced to one of the following causes:—

Air leaks at the Junction of the Carburetter and Engine, or due to worn inlet valve stem and guide.

Faulty Inlet and Exhaust Valve seatings.

Sparkling Plug. Points too close. Try a gap .025 in.

Sparkling Plug oily.

Too much Ignition Advance.

Magneto. Contacts dirty or too close.

Examine Contact Breaker.

Examine Slip Ring for oil.

Examine for Carbon Brush jamming in holder, or glazed on contact face.

Examine for fractured Brush Holder.

Examine for High Tension Cables for shorting.

Magneto Insulation may be broken down, or the interior mechanism wet.

3. **Throttle Valve Cut-away.** (see diagram on page 4). Given satisfactory "idling," set the Magneto Control at half-advance. Air Lever fully open.

Very slowly open the Throttle Valve, when, if the Engine responds regularly up to one-quarter throttle, the Valve Cut-away is correct.

A *weak mixture* is indicated by spitting back through the Air Intake with blue flames, hesitation in picking up, which disappears when the Air Lever is closed down, and this can be remedied by fitting a Throttle Valve with less cut-away.

A *rich mixture* is shown by black smoke from the exhaust. Engine stops, or nearly stops, when the Air Valve is closed. The remedy for this is a Throttle Valve with more cut-away.

Each AMAL Valve is stamped with two numbers, the first indicating the Type No. of the Carburetter, and the second figure the amount of cut-away on the intake side of the Valve in sixteenths of an inch.

Thus 6/4 is a Type 6 Valve with 4/16 in. or 1/4 in. cut-away. The standard valve for Single Cylinder Engines is No. 5, and for Multi-cylinder Engines, No. 4.

#### 4. Needle Position.

Needle positions are counted from the top of the needle, and the groove nearest the needle top is No. 1.

With air full open.

Open the Throttle half-way.

Note if the Exhaust is crisp and the engine lively.

Close Air Valve slightly below throttle, exhaust Note and Engine Speed should then remain practically unaltered.

*Weak mixture.* Raise Needle in Throttle Valve, IF—Popping back and spitting occur with blue flames from Carburetter intake.

Test by lowering Air Valve gently. Engine revolutions will rise when Air Valve is lowered slightly below the Throttle Valve.

*Rich mixture.* Lower Needle in throttle valve, IF—Engine speed does not increase progressively as the throttle is raised; Smoky Exhaust and heavy laboured running; on closing Air Valve slightly below throttle valve, tendency to miss-fire and eight-stroke is present.

The normal needle setting is with the Needle Clip in No. 3 groove.

Having found the correct Needle position, the carburetter setting is now complete, and it will be found that the driving is practically automatic once the Engine is warmed up.

**For a Semi-automatic Setting,** where extreme economy is desired, lower the Needle one groove further after carrying out this range of tests.

For **Speed Work** the Main Jet may be increased by 10%, when the Air Lever should be fully open when on full throttle.

"*Rich mixture.*"—General indications are—heavy thumpy running, emission of black smoke from the exhaust, the inside of the carburetter becomes blackened, and as the throttle is opened, heavy "blowback" of fuel is observed from the carburetter air intake.

"*Weak mixture.*"—Difficult starting, tendency for the engine to fire back through the carburetter, indicated by blue flames from the carburetter air intake. Carburetter becomes sensitive to "drive," and constant use has to be made of the air lever, engine knocks readily and runs hot, with loss of power. The electrode of the sparking plugs shows indications of intense heat, and the mica insulation becomes white, polished exhaust pipes become rapidly blued.

#### TUNING THE AMAL ACCELERATION PUMP CARBURETTER

Due to the simplicity and automatic action of the pump tuning is unnecessary, but it must be remembered that the controlling factor of the pump stroke is the needle position, and this must, of course, be determined in the normal way, as explained earlier in this leaflet, but it is probable that the needle position can be lower than in a carburetter without the pump.

All other means of tuning should be carried out on the Pump type Carburetter in exactly the same way as for the Non-Pump type, but the Main Jet should be approximately 15% larger in the Pump Carburetter than in a carburetter without pump, for example, main jet 150 without pump would mean main jet 170 with pump.

**Important Note.** To start from cold, turn on petrol tap and first open the throttle wide twice and then close to the best starting position. This primes the carburetter better than flooding. Do not open and shut the throttle unnecessarily when the machine is not running, otherwise you might over-prime the carburetter. If you do over-prime open the throttle wide and give a couple of kicks, then close down to the best starting position.

The pump action of the carburetter when the engine is running does NOT glut the engine with petrol.

If you remove the Pump Piston see that you replace it the correct way up, that is, with the 4 holes at the top.

AMAL LTD.

**AMAL**  
LIMITED

LIST 294A

## Hints and Tips for 1929-1934 Carburetters

(Needle Jet and Acceleration Pump  
Carburetters).

#### MAINTENANCE OF THE AMAL CARBURETTER.

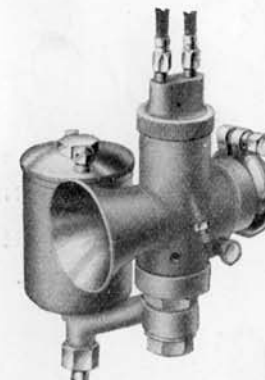

To maintain the efficiency of the Carburetter, you are strongly advised to clean it periodically. This is best done by entirely dismantling and washing each part in clean petrol, and in so doing the following points should be observed:—

If the Jet Block is tight, it should be tapped out by means of a wooden stump in the mixing chamber.

Renew any worn parts, as Needle Valve, if the head has a distinct ridge at the point of seating; Throttle Valve, if

excessive side play is present; Mixing Chamber Union Nut Washer, if worn or damaged; Taper Needle and Clip, if it is possible to rotate the Needle freely in the clip.

Be sure that all Pilot passages are clear, this is done best by inserting a fine bristle.

In re-assembling no brute force is necessary. Make sure that Taper Needle is refitted in correct groove and securely locked by clip: that it enters the central hole in top of Jet Block: that Needle Valve enters top of Float Chamber Cover easily: that Mixing Chamber is fitted vertical and pushed right home on engine stub: that Washer is good, if flange fitting to cylinder: that Needle Valve Clip V registers correctly in groove: it will, of course, be necessary to re-set Pilot Adjusting Screw.

You are strongly recommended to purchase from an Official Service Stockist who exhibits the sign shown here.



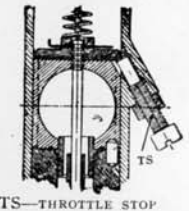

**AMAL**

The Carburetter of  
**RECORDS AND SUCCESSES,  
AND INTERNATIONAL FAME.**

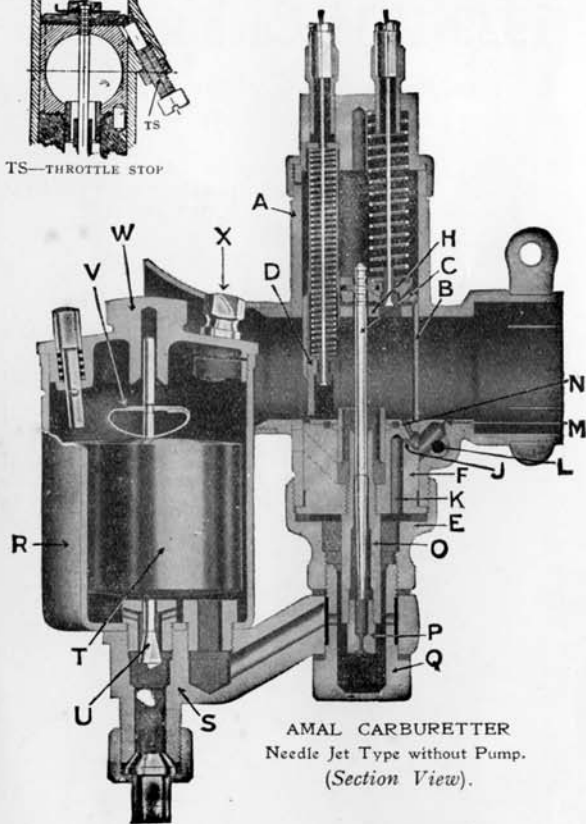

AMAL CARBURETTER  
Needle Jet Type without Pump.  
(Section View).

**AMAL LIMITED,**

Holford Works, Perry Barr, Birmingham 20,  
England  
Telegrams: Amalcarb, 'Phone, B'ham.  
Codes: ABC (5th & 6th Edition), Western  
Union, Bentleys,  
Telephones: BIRchfields 4571 (3 lines).

PRINTED IN ENGLAND.

**THE AMAL NEEDLE JET CARBURETTER. (How it Works).**

The Petrol Tap having been turned on petrol will flow past the Needle Valve U until the quantity of petrol in the Chamber R is sufficient to raise the Float T, when the Needle Valve U will prevent a further supply entering the Float Chamber.

The action of the Float can readily be understood, for, as the quantity of fuel in the Float Chamber is used, the Float T will drop, carrying with it the Needle U, and admitting a further supply. Thus, automatically, the petrol level is kept constant. No alteration should be made to our standard petrol level.

The Float Chamber having filled to its correct level, fuel passes along the passages, through the diagonal holes in the Jet Plug Q, when it will be in communication with the Main Jet P and the Pilot Feed Hole K; the level in these Jets being, obviously, the same as that maintained in the Float Chamber.

Imagine the Throttle Valve B very slightly open. As the piston descends, a partial vacuum is created in the Carburetter, causing a rush of air through the Pilot Air Hole L and drawing fuel from the Pilot Jet J.

The mixture of air and fuel is admitted to the Engine through the Pilot Outlet M.

The quantity of mixture capable of being passed by the Pilot Outlet M is insufficient to run the Engine. This mixture also carries excess of fuel. Consequently, before a combustible mixture is admitted, Throttle Valve B must be slightly raised, admitting a further supply of air from the main air intake.

The further the Throttle Valve is opened, the less will be the depression on the Outlet M, but, in turn, a higher depression will be created on the By-pass N, and the Pilot mixture will flow from this passage as well as from the Outlet M.

The mixture provided by the Pilot and By-pass system is supplemented at approximately 1/4th throttle by fuel from the Main Jet system, the Throttle Valve cut-away governing the mixture strength from here to 1/2 throttle. Proceeding up the throttle range, mixture control by the position of the needle takes place from 1/2 to 3/4 throttle, and thereafter the Main Jet is the only regulation.

The Air Valve D, which is cable-operated on the Two-Lever Carburetter and Hand-operated on the Single-Lever Carburetter, has the effect of obstructing the main through-way, and, in consequence, increasing the depression on the Main Jet, enriching the mixture.

**TUNING THE AMAL NEEDLE JET CARBURETTER.**

See additional instructions, page 6, for pump type carburetter.

There are four ways in which the quality of the mixture supplied by an AMAL Carburetter can be varied, and these are given hereunder, in the order in which the adjustments should be made.

1. Main Jet ( $\frac{3}{4}$  to full throttle).
2. Pilot Air Adjustment (closed to  $\frac{1}{8}$ th throttle).

3. Throttle Valve Cut-away on the air intake side ( $\frac{1}{2}$  to  $\frac{3}{4}$  throttle).
4. Needle position ( $\frac{1}{4}$  to  $\frac{3}{4}$  throttle).

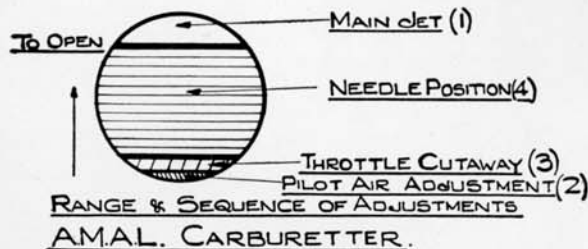

This diagram clearly indicates the part of the throttle range over which each adjustment is effective. The Carburetter having been carefully fitted, the general tuning can be carried out. The following sequence must be observed.

1. **Obtain Main Jet Size**, by selecting the smallest size Jet which gives the maximum speed. The air lever should be  $\frac{3}{4}$  open.

2. **Pilot Adjustment.**  
To weaken slow running mixture screw pilot air adjuster outwards.

To enrich slow running mixture screw pilot air adjuster inwards.

Screw pilot air adjuster home in a clockwise direction. Place gear lever in "neutral."

Slightly flood Float Chamber by gently depressing the Tickler until fuel can be observed overflowing from the Mixing Chamber.

Set Magneto half advance, Throttle approximately  $\frac{1}{2}$  open, close Air Lever, start the Engine and warm up.

After warming up, reduce the Engine revolutions by gently closing the Throttle. The slow running mixture will prove too rich unless air leaks are present.

Very gradually unscrew the Pilot Air Adjuster.

The engine speed will increase and must be again reduced by gently closing the Throttle until, by a combination of Throttle positions and Air adjustment, the desired "idling" is secured.

It is sometimes necessary to retard fully the Magneto before good "idling" results, particularly when the Magneto runs at engine speed, or when excessive valve overlap and very early ignition timing is employed.

**Throttle Stop.** If it is desired that the engine should continue "idling" with the Throttle Lever closed, the position of the Throttle Valve must be set by means of the Throttle Stop Screw, the Throttle Lever being in the "closed position" during this adjustment. Alternatively, if the screw is adjusted clear of the Throttle Valve, the engine will shut off in the normal way by the Control Lever.