

SPARE PARTS LIST

for Carburettors (Motor Cycle) Controls & Air Filters



When Requiring Spare Parts the best course to adopt is to get into touch with one of our AMAL Service Stockists, the addresses of whom are given in our leaflet No. 349. These Service Stockists always hold a wide range of Spares, and are thus in a position to supply promptly the requirements of any Owners or Dealers within their area; should, however, this be inconvenient, we shall be only too pleased to supply from our Chief Spares Dept., Holford Works, Perry Barr, Birmingham, 20.























AMAL
LIMITED

HOLFORD WORKS, :: PERRY BARR,
BIRMINGHAM, 20, : ENGLAND.

'Phone: BIRchfield 4571 (5 lines).

Telegrams: Amalcarb, 'Phone, Birmingham.

AMAL MIXING CHAMBER PARTS.

 4/060  4/052 5/052 6/052 29/062  4/037 29/047  4/046 6/046	 4/047 5/047 6/047 29/057  4/045 5/045 6/045 29/055  4/038 6/038 29/048  4/048 6/048 29/072  4/040 6/040 29/050	 46/031 4/031 6/031 29/041  4/049 5/050 6/051  4/048 6/048 29/072  4/040 6/040 29/050	 4/032 6/032 29/042  4/049 5/050 6/051  4/048 6/048 29/072  4/040 6/040 29/050	 6/132  4/035  4/041  4/061 29/076  4/043 29/077  4/042	<p>APPROX OVERALL LENGTH</p> <p>4/065 - 2 1/2" 5/065 - 2 7/8" 6/065 - 3 3/8" 29/075 - 3 3/8"</p> <p>47/032 48/032 49/032</p> <p>47/054 48/054 49/054</p> <p>47/059 49/059</p> <p>47/045 48/045 9/045</p> <p>7/047 9/047</p> <p>49/060</p> <p>47/034 48/034 49/034</p> <p>7/099</p> <p>7/073</p> <p>7/061</p> <p>7/062</p> <p>49/063</p>
---	---	---	---	---	---

PLAIN TYPE RIBBED TYPE

ACCORDING TO ENGINE

JET BLOCK
SEE PARTS LIST

PARTS SPECIAL for NON-NEEDLE TYPE CARBS TYPES - 46 47 48 49/

For Spare Parts List and Prices for above refer to page 3.

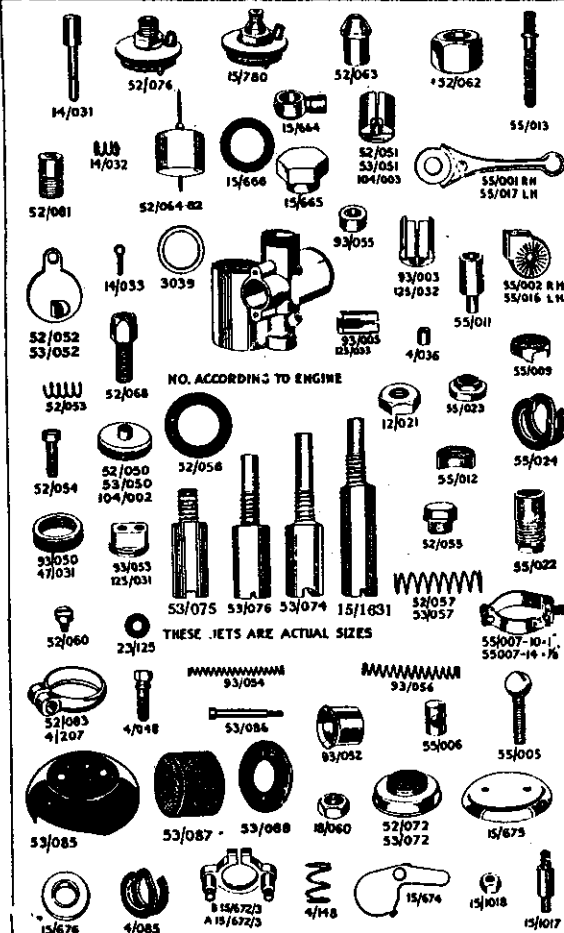

NO. ACCORDING TO ENGINE

THESE JETS ARE ACTUAL SIZES

36/004
36/011
36/009
36/010
36/007
36/008
36/001
36/002
36/003
36/006
36/005

LIGHTWEIGHT 2 JET CARB. WITH COMBINED FLOAT CHAMBER—For Spare Part prices see p. 5

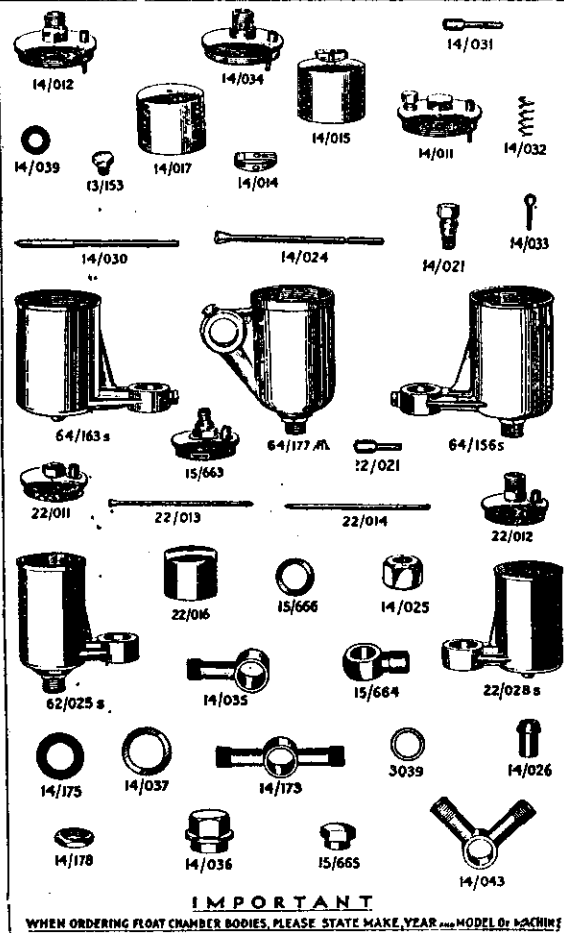

IMPORTANT
WHEN ORDERING FLOAT CHAMBER BODIES, PLEASE STATE MAKE, YEAR AND MODEL BY BACKING

For Spare Part prices see page 4.

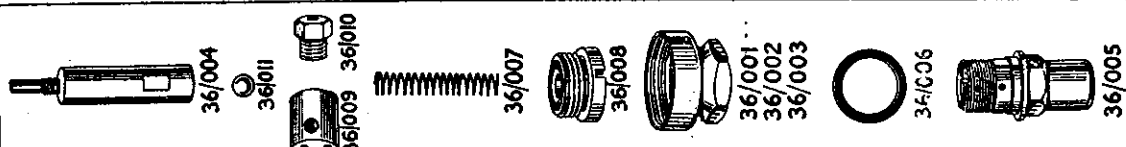

36/004
36/011
36/009
36/010
36/007
36/008
36/001
36/002
36/003
36/006
36/005

PUMP PARTS—For Spare Part prices see page 4.

MIXING CHAMBER PARTS FOR AMAL NEEDLE AND NON-NEEDLE (BINKS) TYPE CARBURETTERS.

Component	NEEDLE TYPE								Price s. d.
	Amal Carburetters				Binks or Non-Needle Type Carburetters				
	Type 4/ & 74/	Type 5/ & 75/	Type 6/ & 76/	Type 29/ & 89/	Type 46/	Type 47/	Type 48/	Type 49/	
Mixing Chamber	According to Engine	—	—	—	According to Engine	According to Engine	—	—	8 0
Ditto	According to Engine	—	—	—	—	—	—	—	10 0
Ditto	According to Engine	According to Engine	—	—	—	—	—	—	12 0
Ditto	—	—	According to Engine	According to Engine	—	—	According to Engine	According to Engine	14 0
Jet Block and Barrel	—	—	—	—	—	—	—	—	—
complete, size 17	4/057	—	—	—	—	—	—	—	5 0
Ditto	4/058	—	—	—	—	—	—	—	5 0
Ditto	4/059	—	—	—	—	—	—	—	5 0
Ditto	—	5/057	—	—	—	—	—	—	5 0
Ditto	—	5/058	—	—	—	—	—	—	5 0
Ditto	—	—	6/057	—	—	—	—	—	5 0
Ditto	—	—	6/058	—	—	—	—	—	5 0
Ditto	—	—	6/059	—	—	—	—	—	5 0
Ditto	—	—	—	29/068	—	—	—	—	6 6
Ditto	—	—	—	29/069	—	—	—	—	6 6
Ditto	—	—	—	29/070	—	—	—	—	6 6
Ditto	—	—	—	29/071	—	—	—	—	6 6
Mixing Chamber Union Nut	4/062	4/062	6/062	—	—	47/033	4/062	6/062	1 6
Ditto	—	—	—	29/072	—	—	—	—	1 11
Mixing Chamber Cap	4/031	4/031	6/031	—	—	47/031	4/031	6/031	1 9
Ditto Ditto	—	—	—	29/041	—	—	—	—	2 0
Ditto Ditto	—	—	—	—	46/031	—	—	—	1 6
Mixing Chamber Top	4/032	4/032	6/032	—	—	47/032	48/032	49/032	1 9
Ditto Ditto	—	—	—	29/042	—	—	—	—	2 2
Cable, per length complete	—	—	—	—	—	—	—	—	2 3
Midway Cable Adjusters	—	—	—	—	—	—	—	—	1 0
Cable Stop, top hat shape	6/132	6/132	6/132	—	—	6/132	6/132	6/132	2 2
Cable Adjuster	4/035	4/035	4/035	4/035	4/035	4/035	4/035	4/035	4 4
Cable Nipples	1482	1482	1482	1482	1482	1482	1482	1482	2 2
Throttle Valve Spring	4/037	4/037	4/037	29/047	4/037	4/046	4/046	6/046	3 3
Air Funnel	4/038	4/038	6/038	—	—	4/038	4/038	6/038	2 6
Ditto	—	—	—	29/048	—	—	—	—	3 0
Washer for Jet Block	4/040	4/040	6/040	29/050	—	47/040	4/040	6/040	2 2
Spring Clip for Needle	4/041	4/041	4/041	4/041	—	—	—	—	4 4
Holding Bolt	4/043	4/043	4/043	29/077	4/043	4/043	4/043	4/043	2 0
Air Valve	4/045	5/045	6/045	—	—	47/045	48/045	9/045	2 6
Ditto	—	—	—	29/055	—	—	—	—	2 9
Air Valve Spring	4/046	4/046	4/046	4/046	—	4/046	4/046	6/046	3 3
Air or Throttle Valve Guide	4/047	4/047	6/047	—	—	7/047	4/047	9/047	2 2
Ditto	—	—	—	29/057	—	—	—	—	4 4
Outlet Clip Screw	4/048	4/048	4/048	4/048	4/048	4/048	4/048	4/048	6 6
*Outlet Clip for 1-in. Outlet	4/049	4/049	4/049	—	—	4/049	4/049	—	1 9
* Ditto 1 1/2-in. ditto	—	5/050	5/050	—	—	—	5/050	5/050	1 9
* Ditto 1 1/4-in. ditto	—	—	—	27/058	—	—	—	—	2 3
* Ditto 1 1/2-in. ditto	—	—	6/051	6/051	—	—	—	6/051	1 9
* Ditto 1 1/4-in. ditto	—	—	—	27/059	—	—	—	—	2 0
* Ditto 1 1/2-in. ditto	—	—	—	—	46/040	—	—	—	1 4
* Ditto 1 1/4-in. ditto	—	—	—	—	46/041	—	—	—	1 4
Throttle Valve	4/052	5/052	6/052	—	—	47/054	48/054	49/054	3 10
Ditto	—	—	—	29/062	—	—	—	—	4 0
Ditto .35 bore	—	—	—	—	46/032	—	—	—	2 6
Ditto .41 bore	—	—	—	—	46/033	—	—	—	2 9
Throttle Valve .468 bore	—	—	—	—	46/034	—	—	—	3 0
Ditto .531 bore	—	—	—	—	46/035	—	—	—	3 0
Ditto .60 bore	—	—	—	—	46/036	—	—	—	3 0
Holding Bolt Washer	4/053	4/053	4/053	4/053	4/053	4/053	4/053	4/053	2 2
Needle Jet	4/061	4/061	4/061	29/076	—	—	—	—	1 9
Needle for Jet	4/065	5/065	6/065	29/075	—	—	—	—	1 3
Air Adjusting Screw	13/129	13/129	13/129	13/129	—	—	—	—	6 6
Spring for ditto	4/148	4/148	4/148	4/148	—	—	—	—	2 2
Filter	—	—	—	—	—	49/063	49/063	49/063	1 6
Filter complete	—	—	—	—	7/073	—	—	—	6 6
Jet Key	—	—	—	—	7/099	7/099	7/099	7/099	1 0
Main Jet	4/042	4/042	4/042	4/042	—	—	—	—	5 5
Ditto	—	—	—	—	7/062	7/062	7/062	7/062	5 5
Pilot Jet	—	—	—	—	7/061	7/061	7/061	7/061	5 5
Throttle Stop Screw	4/063	4/063	4/063	4/063	—	47/059	49/059	49/059	6 6
Ditto ditto Lock Nut	16/010	16/010	16/010	16/010	—	49/060	49/060	49/060	2 2
Split Cotter Pin for Throttle Valve	4/060	4/060	4/060	4/060	—	—	—	—	2 2
Strangler Thimble	—	—	—	—	46/037	—	—	—	1 0
Strangler Inner Sleeve	—	—	—	—	46/038	—	—	—	1 0
Strangler Lever	—	—	—	—	46/039	—	—	—	6 6
Valve Location Peg	—	—	—	—	49/086	—	—	—	3 3
Strangler Spring	—	—	—	—	46/042	—	—	—	3 3
Special Throttle Valve	—	—	—	—	—	47/055	—	—	3 10
Special Air Valve	—	—	—	—	—	47/056	—	—	2 0
Levis Throttle Valve	—	—	—	—	—	47/131	—	—	3 10
Jet Seat	—	—	—	—	—	47/034	48/034	49/034	1 0

Types 4/ 5/ 6/ and 29/ are Brass Mixing Chambers. Types 74/ 75/ 76/ and 89/ are Die-cast Mixing Chambers
 *Please State if Plain or Ridged Type. Pump Parts detailed on Page 4
 Letter P stamped after Carburettor Type denotes Carburettor is Pump Type.

DETAILS OF PUMP PARTS FOR NEEDLE TYPE STANDARD AMAL CARBURETTERS.

Component	Types 4/ & 74/	Types 5/ & 75/	Types 6/ & 76/	Types 29/ & 89/	Price s. d.
Mixing Chamber Union Nut	36/001	36/001	36/002	36/003	2 0
Needle Jet	36/004	36/004	36/004	36/004	2 6
Holding Bolt	36/005	36/005	36/005	36/005	2 6
Fibre Washer	36/006	36/006	36/006	36/006	2
Plunger Spring	36/007	36/007	36/007	36/007	3
Plug for Needle Jet	36/008	36/008	36/008	36/008	1 6
Pump Plunger	36/009	36/009	36/009	36/009	1 0
Ball Seating Plug	36/010	36/010	36/010	36/010	6
Steel Ball	36/011	36/011	36/011	36/011	1

FLOAT CHAMBER PARTS AND PRICES FOR TYPES FROM 1929 TO 1934.

Component	PART NUMBERS				Price s. d.
	Large Float Chamber		Small Float Chamber		
	Bottom Feed	Top Feed	Bottom Feed	Top Feed	
Float Chamber Complete, Twin Standard	14/076	14/096	—	—	33 0
Float Chamber Complete	64/079	64/099	—	—	18 0
Ditto ditto Single Standard	—	—	62/079	62/099	14 6
*Float Chamber Body	64/155SP	64/162SP	—	—	12 0
*Ditto ditto	64/155SBP	64/162SBP	—	—	12 0
*Ditto ditto	64/153LP	64/157LP	—	—	12 0
*Ditto ditto	64/153LBP	64/157LBP	—	—	12 0
*Ditto ditto	64/154L	64/161L	—	—	12 0
*Ditto ditto	64/154LB	64/161LB	—	—	12 0
*Ditto ditto	64/158S	64/163S	—	—	12 0
*Ditto ditto	64/158SB	64/163SB	—	—	12 0
*Ditto ditto	—	64/187 Bent	—	—	14 6
*Ditto ditto	—	—	62/025S	62/028S	8 6
*Ditto ditto (Horizontal)	64/177HZ	64/176HZ	22/001SP	22/002SP	8 6
*Ditto ditto ditto	—	—	22/005/15HZ	22/006/15HZ	8 6
*Ditto ditto	14/009 Twin	14/010 Twin	—	—	20 0
*Ditto ditto	14/009 Twin-P	14/010 Twin-P	—	—	20 0
Float Chamber Cover (Standard)	14/011	14/012	22/011	22/012	2 6
Float Chamber Cover (for Banjo fitting)	—	14/034	—	15/663	2 6
Float Chamber Cover Lock Screw	14/021	—	—	—	3
Float	14/015	14/017	22/016	22/016	2 6
Needle Valve	14/024	14/030	22/013	22/014	11
Float Chamber Needle Clip	—	161/054	—	—	4
Tickler	14/031	14/031	22/021	22/021	7
Tickler Spring	14/032	14/032	14/032	14/032	2
Tickler Cotter Pin	14/033	14/033	14/033	14/033	1
Petrol Union Nut	14/025	14/025	14/025	14/025	6
Petrol Union Nipple	14/026	14/026	14/026	14/026	3
Bow Spring for Float	14/014	—	—	—	3
Banjo Connection (Single)	14/035	14/035	—	—	2 0
Ditto ditto ditto direct pipe fitting	—	—	—	15/664	1 6
Ditto ditto (Twin 90°)	14/043	14/043	—	—	4 6
Ditto ditto (Twin 180°)	14/173	14/173	—	—	4 6
Banjo Connection Nut	14/036	14/036	—	15/665	6
Banjo Connection Nut Washer	14/037	14/037	—	—	2
Banjo Connection Copper Washer	—	—	—	3039	2
Banjo Connection Fibre Washer	—	—	—	15/666	1
Float Chamber Platform Plug Screw	13/153	13/153	—	—	2
Washer for above	14/039	14/039	—	—	1
Seating Locknut	14/178	—	14/178	—	3
Seating Washer	14/175	—	14/175	—	2
1/4" Lock Screw for Float Chamber Cover	3319	3319	—	—	2

Please SEND patterns when possible.
 *When ordering Float Chamber Bodies please state finish (Chromium or Black).
 EXTRA CHARGE is made for Float Chamber Bodies having twisted bases.
 *RE FLOAT CHAMBER SYMBOLS :—
 SP denotes Short Base—Pump type.
 SBP .. Short Base—Banjo Pump type.
 LP .. Long Base—Pump type.
 LBP .. Long Base—Banjo Pump type.
 L .. Long Base—Standard type.
 LB .. Long Base—Standard Banjo type.
 S .. Short Base—Standard type.
 SB .. Short Base—Standard Banjo type.
 HZ .. Type fitted to Horizontal Mixing Chamber Carburetters.

SPARES LIST FOR LIGHTWEIGHT 2 JET CARBS. WITH COMBINED FLOAT CHAMBER.

SINGLE LEVER CARBURETTORS TYPES 52/, 53/, 103/, 104/ and 115/.

DOUBLE LEVER CARBURETTORS TYPES 93/ and 125/

MIXING CHAMBER AND FLOAT CHAMBER SPARE PARTS AND PRICES.

Component	Type 52/	Type 53/	Type 93/	Type 103/	Types 104/ & 115/	Type 125/	Price s. d.
Mixing Chamber	*According to Engine	*According to Engine	*According to Engine	*According to Engine	*According to Engine	*According to Engine	12 6
Mixing Chamber Top	52/050	53/050	—	53/050	104/002	—	1 6
Mixing Chamber Ring	—	—	93/050	—	—	—	1 6
Mixing Chamber Ring	—	—	—	—	—	47/031	1 9
Mixing Chamber Top	—	—	93/053	—	—	125/031	1 9
Throttle Valve	52/051	53/051	93/003	53/051	104/003	125/032	2 6
Air Valve	—	—	93/005	—	—	125/033	1 6
Cable Adjuster	52/068	52/068	52/068	52/068	52/068	52/068	4
Cable Nipple (Air Cable)	4/036	4/036	4/036	4/036	4/036	4/036	2
Cable Nipple (Throttle Cable)	—	—	93/055	—	—	93/055	2
Strangler Lever	52/052	53/052	—	—	—	—	6
Strangler Spring	52/053	52/053	—	—	—	—	2
Strangler Screw	52/054	52/054	—	—	—	—	2
Air Tube	—	—	93/052	—	—	93/052	1 0
Jet Plug	52/055	52/055	52/055	52/055	52/055	52/055	1 0
Jet Plug Washer	52/056	52/056	52/056	52/056	52/056	52/056	2
Throttle Valve Spring	52/057	53/057	93/056	53/057	53/057	93/056	3
Air Valve Spring	—	—	93/054	—	—	93/054	3
Outlet Clip (see Note)	52/083	—	—	—	—	—	1 4
Ditto ditto (see Note)	—	4/207	4/207	4/207	4/207	4/207	1 9
Outlet Clip Screw	4/048	4/048	4/048	4/048	4/048	4/048	6
Pilot Jet	53/075	53/075	53/075	53/075	53/075	53/075	5
Main Jet (see Note)	53/076	53/076	53/076	53/076	53/076	15/1631	5
Float Chamber Plug Screw or Valve Locating Screw	52/060	52/060	52/060	52/060	52/060	52/060	2
Petrol Union Nut	52/062	52/062	52/062	52/062	52/062	—	6
Petrol Union Nipple	52/063	52/063	52/063	52/063	52/063	—	3
Float and Needle (Combined)	52/064/082	52/064/082	52/064/082	52/064/082	52/064/082	52/064/082	2 6
Float Chamber Plug Screw Washer	23/125	23/125	23/125	23/125	23/125	23/125	1
Gauze Air Intake, complete	52/072	53/072	53/072	53/072	53/072	53/072	1 6
Tickler	14/031	14/031	14/031	14/031	14/031	14/031	7
Tickler Spring	14/032	14/032	14/032	14/032	14/032	14/032	2
Tickler Cotter Pin	14/033	14/033	14/033	14/033	14/033	14/033	1
Tickler Bush	52/081	52/081	52/081	52/081	52/081	52/081	7
Float Chamber Cover complete with Tickler	52/076	52/076	52/076	52/076	52/076	52/076	2 6
Float Chamber Cover complete with Tickler, Banjo type	15/780	15/780	15/780	15/780	15/780	15/780	2 6
Banjo Connection	15/664	15/664	15/664	15/664	15/664	15/664	1 6
Banjo Connection Nut	15/665	15/665	15/665	15/665	15/665	15/665	6
Banjo Washer (Copper)	3039	3039	3039	3039	3039	3039	2
Banjo Washer (Fibre)	15/666	15/666	15/666	15/666	15/666	15/666	1
Strangler Body and Studs	B15/672/3	A15/672/3	A15/672/3	A15/672/3	A15/672/3	A15/672/3	1 6
Strangler Lever	15/674	15/674	15/674	15/674	15/674	15/674	1 0
Strangler Stud	15/1017	15/1017	15/1017	15/1017	15/1017	15/1017	3
Strangler Stud Nuts, Small	15/1018	15/1018	15/1018	15/1018	15/1018	15/1018	1
Strangler Stud Nuts, Large	18/060	18/060	18/060	18/060	18/060	18/060	2
Strangler Spring	4/148	4/148	4/148	4/148	4/148	4/148	2
Strangler Spring Washer	4/085	4/085	4/085	4/085	4/085	4/085	2
Strangler Cone Washer	15/676	15/676	15/676	15/676	15/676	15/676	3
Strangler Body Clip Pin	52/054	52/054	52/054	52/054	52/054	52/054	2
Strangler Cowl	15/675	15/675	15/675	15/675	15/675	15/675	9
Intake Gauze	—	53/087	53/087	53/087	53/087	53/087	6
Intake Gauze Cowl	—	53/085	53/085	53/085	53/085	53/085	1 0
Intake Gauze Back Plate	—	53/088	53/088	53/088	53/088	53/088	6
Intake Gauze Pins	—	53/086	53/086	53/086	53/086	53/086	4

*When ordering new Mixing Chamber, please state type required (this will be found stamped on the outlet of the old mixing chamber), motor-cycle it is to suit, also type of AIR INTAKE fitted to old Mixing Chamber, i.e., Screwed or Bolt Fixing.
 RE OUTLET CLIPS. Please send pattern when ordering; failing this, please state whether plain or ridged type is required.
 RE MAIN JET. Please send pattern when ordering; failing this, please state number of Jet and overall length.
 For Control details, see page 7. For Air Filter details, see page 8.

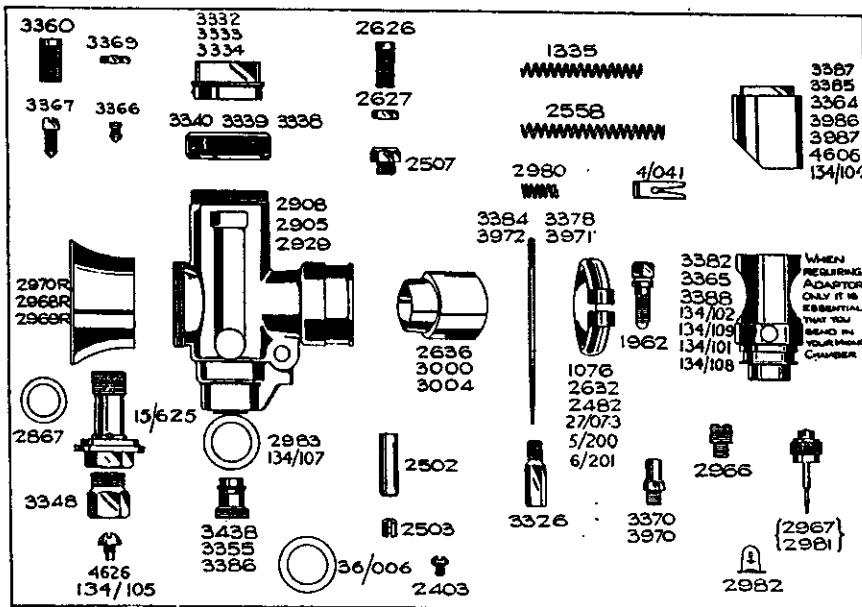

SPARE PARTS LIST FOR AMAL T.T.32 & T.T.34 CARBURETTER MIXING CHAMBERS.

Component	Type 25/	Type 15/	Price s. d.	Type 10/	Price s. d.
*Mixing Chamber only	According	to Engine	18 0	—	20 0
Mixing Chamber Top	3332	3333	1 9	3334	2 2
Mixing Chamber Cap	3340	3339	1 9	3338	2 2
Cable Adjuster (Air)	2626	2626	4	2626	4
Cable Adjuster Locknut	2627	2627	2	2627	2
Jet (State Fuel used)	3326	3326	1 0	3326	1 0
Jet Choke Tube	3438	3438	1 9	3438	1 9
Air Valve	2502	2502	1 0	2502	1 0
Air Valve Spring	2558	2558	3	2558	3
Throttle Valve	3986	3984	3 10	3987	4 3
Ditto TT34	—	4606	3 10	134/104	4 3
Throttle Valve Spring	2558	2558	3	2558	3
Air Barrel Top	2507	2507	7	2507	7
Carburettor Cable Nipple	2629	2629	2	2629	2
Outlet Liner	2636	3000	9	3004	1 9
Outlet Clip	1076	2632	1 9	2482	2 2
ditto TT34 1 1/2" outlet	—	5/200	1 9	—	—
ditto ditto 1 1/2" outlet	—	6/201	1 9	—	—
ditto ditto 1 1/2" outlet	—	—	—	27/073	2 0
ditto ditto 1 1/2" outlet	—	—	—	27/072	2 3
Outlet Clip Pin	1962	1962	6	1962	6
Adaptor Location Peg	4626	4626	3	4626	3
ditto ditto TT34	—	134/105	3	134/105	3
Air Barrel Plug	2633	3966	6	3969	6
Air Tube	2970R	2968R	2 6	2969R	3 0
Pilot Needle	2981	2981	1 0	2981	1 0
Pilot Needle Insert	2966	2966	1 0	2966	1 0
Pilot Needle Spring	2980	2980	2	2980	2
Pilot Needle Spring Catch	2982	2982	2	2982	2
Jet Holder	15/625	15/625	2 6	15/625	2 6
Adaptor Washer	2983	2983	2	2983	2
ditto TT34	—	134/107	2	134/107	2
Lock Plunger for M/C top	3366	3366	4	3366	4
Adjusting Screw for ditto	3367	3367	2	3367	2
Throttle Cable Adjuster	3360	3360	4	3360	4
T/C Adjuster Locknut	3369	3369	2	3369	2
Needle Jet	3970	3970	1 9	3970	1 9
Nipple Holder for Air Valve	2503	2503	2	2503	2
Jet Holder Washer	2867	2867	2	2867	2
Needle Clip	4/041	4/041	4	4/041	4
Locking Screw for Air Tube	3932	3932	2	3932	2
Small Plug Screw	2403	2403	2	2403	2
Float Chamber Lug Washer	36/006	36/006	2	36/006	2
Jet Holder Plug	3348	3348	6	3348	6
Needle	3972	3971	1 3	3971	1 3
*Choke Adaptor (State Fuel used)	3382	3365	5 0	3388	5 0
ditto TT34, 1" Bore	—	134/109	5 0	—	—
ditto TT34, 1 1/8" Bore	—	134/102	5 0	—	—
ditto TT34, 1 1/4" Bore	—	—	—	134/108	6 6
ditto TT34, 1 3/8" Bore	—	—	—	134/101	6 6
Gauze for Jet Holder	15/973	15/973	4	15/973	4

*Send Mixing Chamber for Adaptor to be fitted. For Float Chamber details refer to page 4.
 *These prices are for Brass Parts only. For parts in light metal (RR50) add 25% to list price.

AMAL RACING (BINKS) TWIST GRIP PARTS.

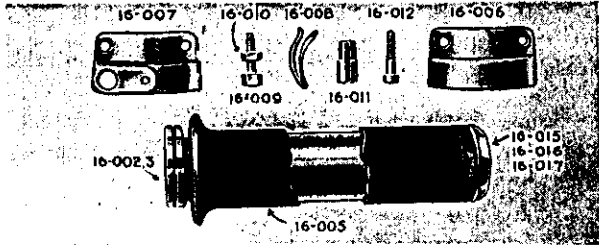

Component	Number	Price
Inner Sleeve and Rotor (long)	16/001-3	3 6
Inner Sleeve and Rotor (short)	16/002-3	3 0
Grip	(long 16/023)	1 0
	(short 16/024)	1 0
Body (top half) R.H.	16/006	3 0
Body (bottom half) R.H.	16/007	3 0
Friction Spring	16/008	6
Screw for Friction Spring	16/009	4
Locknut for ditto	16/010	2
Cable Stop	16/011	4
Screw for Body (2)	16/012	3
Liner for Long Twist Grip	16/013	1 6
Liner for Short Twist Grip	16/014	1 6
End Cap (1-in. bar)	16/015	4
End Cap (3/4-in. bar)	16/016	4
End Cap with closed end	16/017	4
Inner Wire, per foot	—	2
Outer Wire, per foot	—	6
1 length of Cable complete	—	2 3

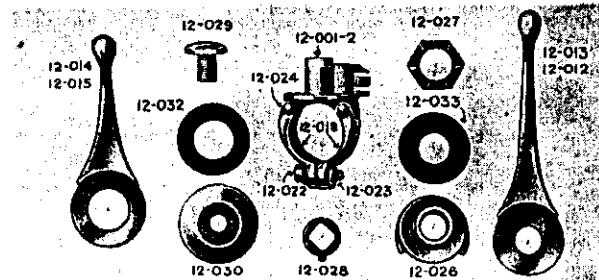

LEVER CONTROLS.

Component	AID	AOD	AIS	AOS	Price
Control Body	12/001	12/002	12/003	12/004	1 10
THROTTLE OR MA G. LEVER RS ONLY					
Lever 4 1/2 long O/A	12/012	12/013	—	—	2 6
.. 3 1/2 .. O/A	12/014	12/015	—	—	2 6
.. 3 1/4 .. O/A	12/016	12/017	—	—	2 6
AIR LEVERS ONLY					
Lever 4 1/2 long O/A	—	—	12/412	12/413	2 6
.. 3 1/2 .. O/A	—	—	12/414	12/415	2 6
.. 3 1/4 .. O/A	—	—	12/416	12/417	2 6
Handlebar Clip 1"	12/018	12/018	12/018	12/018	6
Handlebar Clip 3/4"	12/019	12/019	12/019	12/019	6
H'bar Clip Screw	12/022	12/022	12/022	12/022	3
Clip Screw Nut	12/023	12/023	12/023	12/023	3
H'bar Clip Rivet	12/024	12/024	12/024	12/024	2
Cable Ferrules	12/025	12/025	12/025	12/025	2
Division Plate	12/026	12/026	—	—	5
Adjusting Nut	12/027	12/027	—	—	6
Locking Washer	12/028	12/028	—	—	3
Control Bolt	12/029	12/029	12/029	12/029	3
Control Cap	12/030	12/030	12/031	12/031	5
Spring Washer ea.	12/032	12/032	12/033	12/033	2
Cable Nipple	12/034	12/034	12/034	12/034	2
Inner Wire, pr. ft.	—	—	—	—	2
Outer Cable, ..	—	—	—	—	6
1 length of Cable complete	—	—	—	—	2 3

AID.—Double Lever Control, open in on R.H. Bar.
AOD.—Double Lever Control, open out on R.H. Bar.
AIS.—Single Lever Control, open in on R.H. Bar.
AOS.—Single Lever Control, open out on R.H. Bar.

AMAL TWIST GRIP.

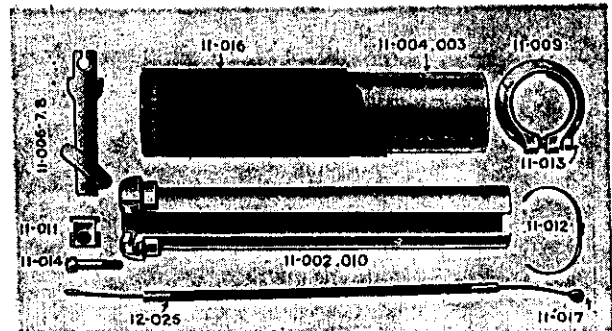

Component	Number	Price
Inner Sleeve and Front Clip	(long 11/001 and 010) (short 11/002 and 010)	3 3
Outer Sleeve complete	(long 11/004 and 003) (short 11/005)	3 3
*Slide Strip, R.H.	11/022R	1 0
*Slide Strip, L.H.	11/022L	1 0
Rear Clip	11/009	1 9
Cable Stop (Short)	11/011	9
Cable Stop (Long)	11/045	9
Spring	11/012	4
Pin for Rear Clip	11/013	3
Pin for Front Clip	11/014	3
Rubber Grip	(6-in. long 11/015) (4 1/2-in. short 11/016)	9
Cable Nipple	11/017	2
Liner for Twist Grip (3/4-in. bar only)	(long 11/018) (short 11/019)	1 6
Dummy Grip 3/4-in.	(6 1/2-in. long 11/030) (4 1/2-in. short 11/031)	1 6
Dummy Grip 1-in.	(6 1/2-in. long 11/033) (4 1/2-in. short 11/034)	1 6
Dummy Grip End Cap, 1-in. grip	11/032	4
Dummy Grip End Cap, 3/4-in. grip	11/035	4
Dummy Grip End Cap, closed end	11/036	4
Inner Wire, per foot	—	2
Outer Cable, per foot	—	6
1 length of Cable complete	—	2 3

*NOTE—The illustration No. for this part is shown as 11/006-7-8.

TYPE 55 CONTROL.

Component	Number	Price
Control Cap	55/023	9
Spring	55/024	2
Lever .. R.H.	55/001	1 6
.. L.H.	55/017	1 6
Body .. R.H.	55/002	1 0
.. L.H.	55/016	1 0
Base and Clip, 1-in.	55/007-10	1 6
Base and Clip, 3/4-in.	55/007-14	1 6
Body (Bracket fixing)	55/012	1 0
Body (Bracket fixing) Pin	55/013	3
Body (Bracket fixing) Pin Nut	12/021	2
Control Clip Screw	55/005	3
Control Clip Screw Nut	55/006	2
Cable Ferrule	55/011	4
Lever Bush	55/022	2
Clip Body	55/009	6

This scan is explicit for non-commercial use and is not intended for financial or material gain by anyone

AIR FILTER SPARES LIST (MOTOR CYCLE).

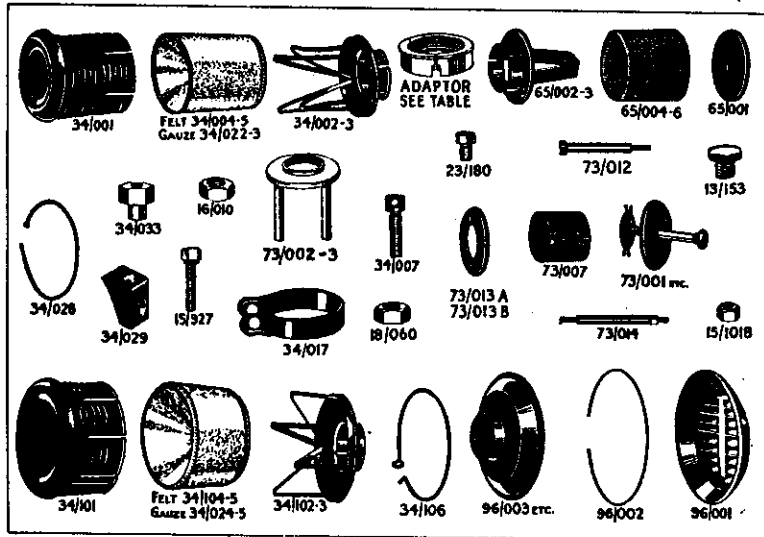

TYPE 34/101C & 34/001C SPARES.

Component	Felt Gauze Part No.	34/101C Part No.	34/001C Part No.	Price
Air Filter, Case and Cowl ..	34/101	34/001		1/6
Air Fil'r Case End S'dle Piece for felt ..	34/102	34/002		1/3
Felt Bag ..	34/103	34/003		9d.
Gauze Bag ..	34/104-5	34/004-5		1/0
Wire Clip ..	34/106	34/028		4d.
Clip Pin ..	34/007			3d.
Clip Lug ..		34/029		6d.
Clip Pin Nut ..	18/060	34/033		3d.
Outlet Clip ..	34/017	34/017		6d.
Outlet Clip Pin ..	15/927	15/927		3d.
Nut for ditto ..	16/010	16/010		2d.

TYPE 73 SPARES.

Component	73/100	73/101	73/102	73/103	73/104	Price
End Plate ..	—	—	73/001	73/001	—	s. d. 6
End Plate with Strangler Plate ..	73/001	73/001	—	—	73/001	} 1 6
Click Spring ..	30/064	30/064	—	—	30/064	
Operating Rod ..	73/015	73/015	—	—	73/015	} 1 6
Operating Rod Knob ..	73/006	73/006	—	—	73/006	
Gauze ..	73/007	73/007	73/007	73/007	73/007	6.
Outlet Plate, 3/8 bore ..	—	73/013A	73/013A	—	73/013A	6
Outlet Plate, 1/2 bore ..	—	73/013B	73/013B	—	73/013B	6
Outlet Plate, Screwed with Guide Rods ..	73/002	—	—	73/002	—	} 1 0
Guide Rods ..	73/003	—	—	73/003	—	
Guide Rod Screw ..	23/180	—	—	23/180	—	2
Guide Rod ..	—	73/012	73/012	—	73/014	3
Guide Rod Nut ..	—	—	—	—	15/1018	1
.. .. Knurled Nut ..	—	—	—	—	73/021	2

73/100=Screw on Intake. 73/102=As 73/101 Less Strangler.
 73/103=As 73/100 Less Strangler. 73/101=Bolt Fixing to Carb.
 73/104=Stud Fixing for 53/Carburettor.

ADAPTORS SUITABLE for this TYPE.

No. of Adaptor	Dia. of Carb. Intake and/or Elbow Dia. C.	Threads per in.
34/016	1 1/4" (29.75 m/m)	24
34/015	1 1/4" (31.74 m/m)	24
34/014	1 3/8" (30.15 m/m)	28
34/013	1 1/2" (31.74 m/m)	20
34/012	1 1/8" (36.5 m/m)	24
34/011	1 7/8" (36.5 m/m)	28
34/010	1 7/8" (36.5 m/m)	20
34/009	1 1/8" (26.97 m/m)	24

Price 1/- each.

TYPE 65/001C SPARES.

Component	Part No.	Price
End Plate ..	65/001	6
Outlet End Plate with Support ..	65/002	} 1 3
Gauze ..	65/003	
Outlet Clip ..	65/004-6	1 0
Outlet Clip Pin ..	34/017	6
Outlet Clip Pin ..	15/927	3
Nut for Ditto ..	16/010	2
Support Screw ..	13/153	3

Adaptors as above table in 34/101C and 34/001C Section.

TYPE 96/ SPARES.

Component	Part No.	Price
End Plate ..	96/001	1 6
Spring Clip ..	96/002	3
Outlet complete with Fine Mesh Gauze ..		} 4 0
Coarse Mesh Gauze ..		
For Adaptor see table below for Part No.		

No. of Adaptor	Diameter of Carburettor Intake	T/ths per in.	For Carb.
96/006	1 1/8" (26.97m/m)	24	47, 48, 74, 75
96/012	1 1/2" (31.74m/m)	24	49, 76
96/009	1 3/8" (36.5m/m)	24	29
96/007	"	20	
96/008	"	28	
96/009	"	24	} various old type carbs.
96/010	1 1/4" (31.74m/m)	20	
96/011	1 3/8" (30.15m/m)	28	
96/013	1.17" (29.72m/m)	24	
96/014	1 gas 1.04" dia. (26.5m/m)	14	

ELBOW ADAPTOR

Price 3/- each.

Angle of Elbow "B"	Number of Elbow	Dia. of Carb. Intake "A"	Threads per in. on Carb. Intake
30°	15/007	1 1/8" (26.97m/m)	24
30°	15/022	1 3/8" (36.5m/m)	24
30°	15/010	1 1/2" (31.74m/m)	24
30°	15/016	(1 1/4" (31.74m/m)	20
30°	15/025	1 3/8" (36.5m/m)	20
30°	15/017	1 3/8" (30.15m/m)	28
30°	15/024	1 3/8" (36.5m/m)	28
60°	15/004	1 1/8" (26.97m/m)	24
60°	15/008	1 3/8" (36.5m/m)	24
60°	15/003	1 1/2" (31.74m/m)	24
60°	15/012	1 1/4" (31.74m/m)	20
60°	15/011	1 3/8" (36.5m/m)	20
60°	15/013	1 3/8" (30.15m/m)	28
60°	15/009	1 3/8" (36.5m/m)	28
60°	15/019	Bell Mouth	—
90°	15/005	1 1/8" (26.97m/m)	24
90°	15/026	1 3/8" (36.5m/m)	24
90°	15/006	1 1/2" (31.74m/m)	24
90°	15/014	1 1/4" (31.74m/m)	20
90°	15/029	1 3/8" (36.5m/m)	20
90°	15/015	1 3/8" (30.15m/m)	28
90°	15/060	1 3/8" (36.5m/m)	28