



October, 1956.

LIST No. 340 (Issue No. 2)

CARBURETTERS

**For all Motor Cycles 175 to 1000 c.c. capacity
Carburetter Types 274, 275, 276 & 289.**

See page 2

**For Auto-cycles and Small Engines
Carburetter Types 359, 361 & 223.**

See page 3

**For Lightweights, Small Marine and Stationary
Engines, Carburetter Types 352 & 353.**

See page 4

HOW TO ORDER:—

Select a suitable type carburetter, for the machine by referring to pages 2, 3, and 4. Never select a carburetter just because it happens to fit the induction pipe or flange, note that carburetters of the same outward size may have different cross bores. The cross bore or choke size (as indicated by reference 2 in illustrations at top of pages 2, 3, and 4) are of vital importance to the engine and your attention is drawn to the guide tables on each page as to the correct size.

STANDARD MACHINES. If ordering a carburetter to suit a standard machine state :—year of manufacture, make of machine and model.

OTHER MACHINES. If ordering a carburetter to suit a machine which is not standard state :—Type, make and capacity of engine, two or four stroke, maximum revolutions, size of attachment pipe or flange, type of petrol connection, if top or bottom feed float chamber is required, position of float chamber, whether right or left hand, angle to vertical if carburetter is inclined, type of controls by which carburetter is to be operated, type of fitment on air intake, i.e., strangler, air filter, etc.

HANDLEBAR CONTROLS.

When ordering controls to operate the carburetter state :—Length of cables required, type of control required and the bar diameter which it is to fit. Twin carburetters can be controlled by a single twist grip for throttles, and single lever for air by means of junction boxes ; state their position in cable length. See appropriate lists describing " Amal Controls."

SERVICE.

Instructions are available for each type of Carburetter in pamphlets called " Hints and Tips," and replacement parts are numbered in official spares lists :—

For Carburetter type 274, 275, 276, 289	..	Hints and Tips List 294, and Spares List 351.
For Carburetter type 359	..	Hints and Tips List 420, and Spares List 464.
For Carburetter type 361	..	Hints and Tips List 420, and Spares List 465.
For Carburetter type 223	..	Hints and Tips List 420, and Spares List 453.
For Carburetter type 352 and 353	..	Hints and Tips List 420, and Spares List 351 for types 52 and 53.

For advice and spare parts first apply to our appointed Service Stockists. See List 349 for Gt. Britain and 354 overseas.

GUARANTEE.—The Company take all possible reasonable care in the manufacture and the quality of their products. Purchasers are informed that, any part proved to be defective in manufacture or quality, and returned to the works within six months of its purchase new, will be replaced. The Company must respectfully point out however, that its responsibility and that of its agents, stockists and dealers, is limited to this Guarantee, and that they cannot, under any circumstances, be held responsible for any loss or for any contingent or resulting liability arising through any defect. These conditions of sale and use also apply when the Company's products form part of the original equipment of machines purchased new.

2,000/10/56 W.

Printed in England.

**AMAL LTD., HOLDFORD ROAD, WITTON,
BIRMINGHAM 6, ENGLAND**

'Phone : Birmingham, BIRchfields 4571.
(P.B.X. 6 lines)

Telegrams : "AMALCARB, 'PHONE.
BIRMINGHAM."

TYPES 274, 275, 276 & 289.

Double Control Carburetters with Needle Jet and Pilot Jet

For all Motor Cycles 175 to 1000 c.c. capacity

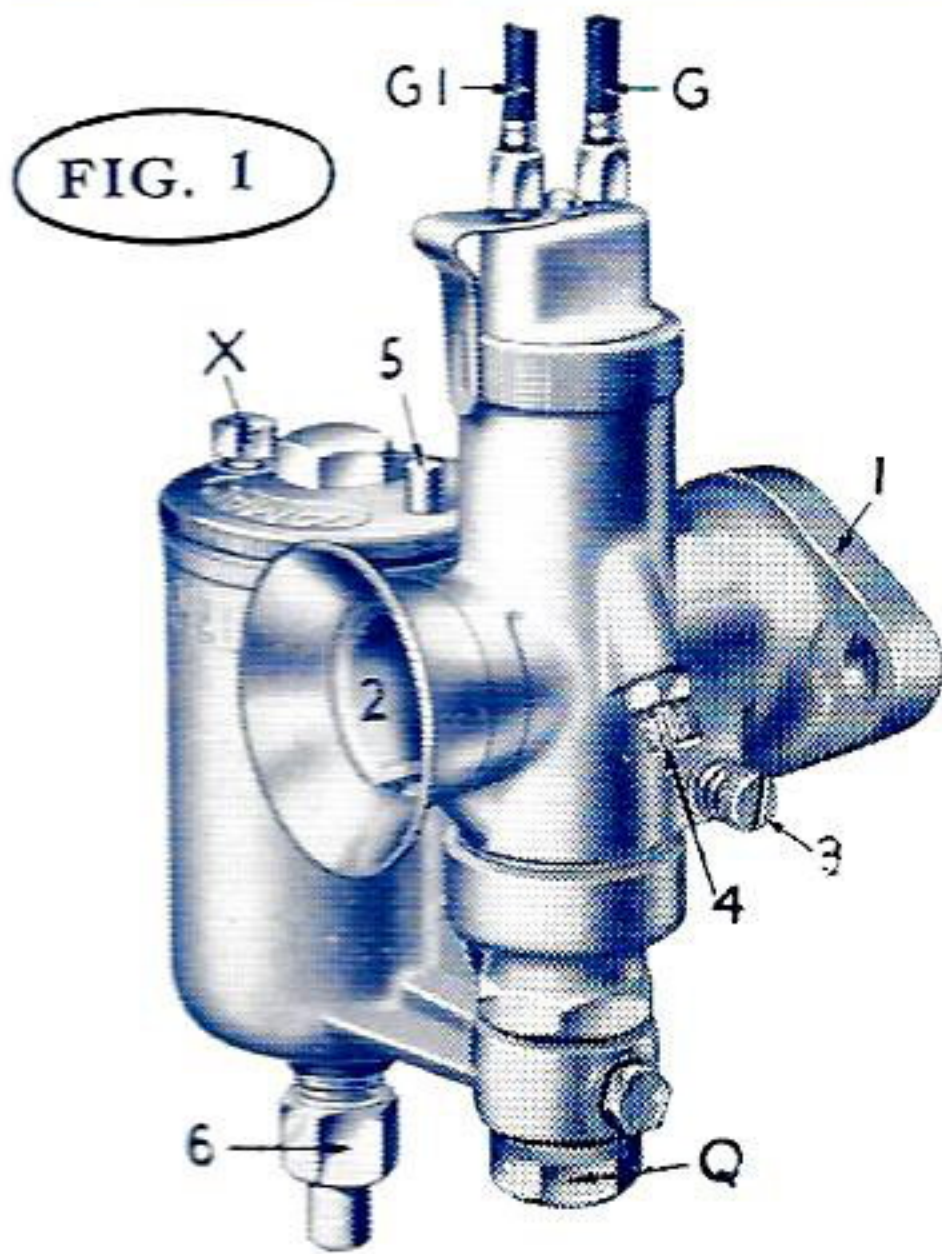

**Vertical Model.
Double Control from Handlebar.**

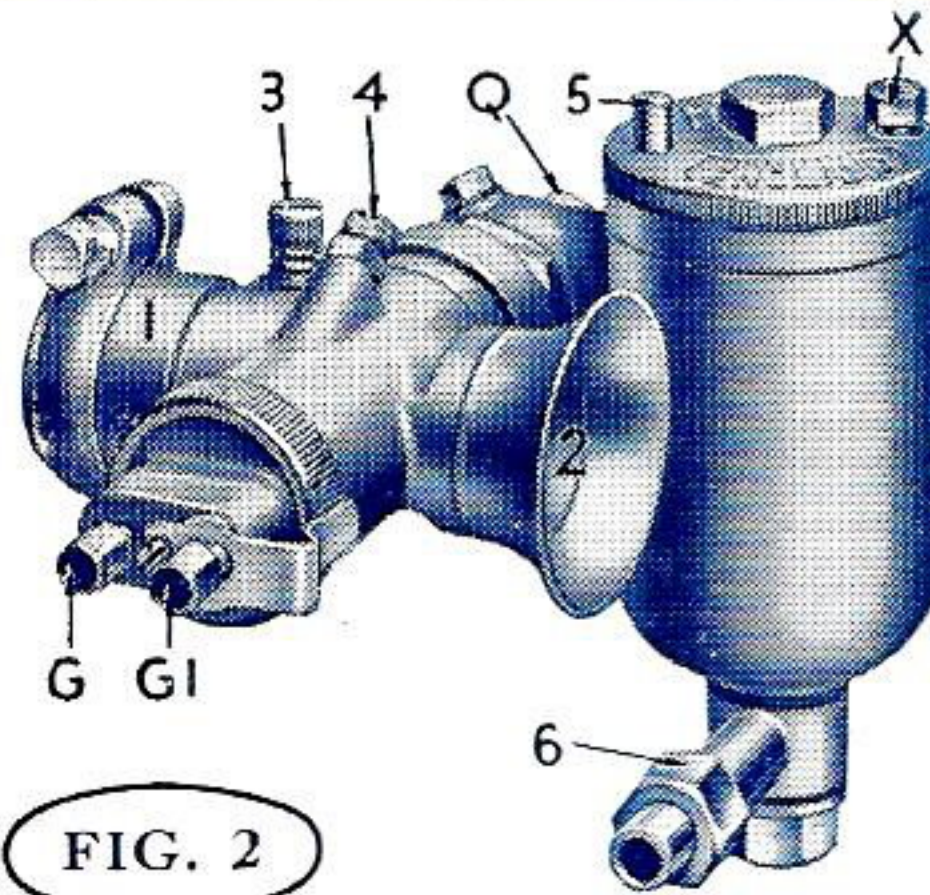

**Horizontal Model.
Double Control from Handlebar.**

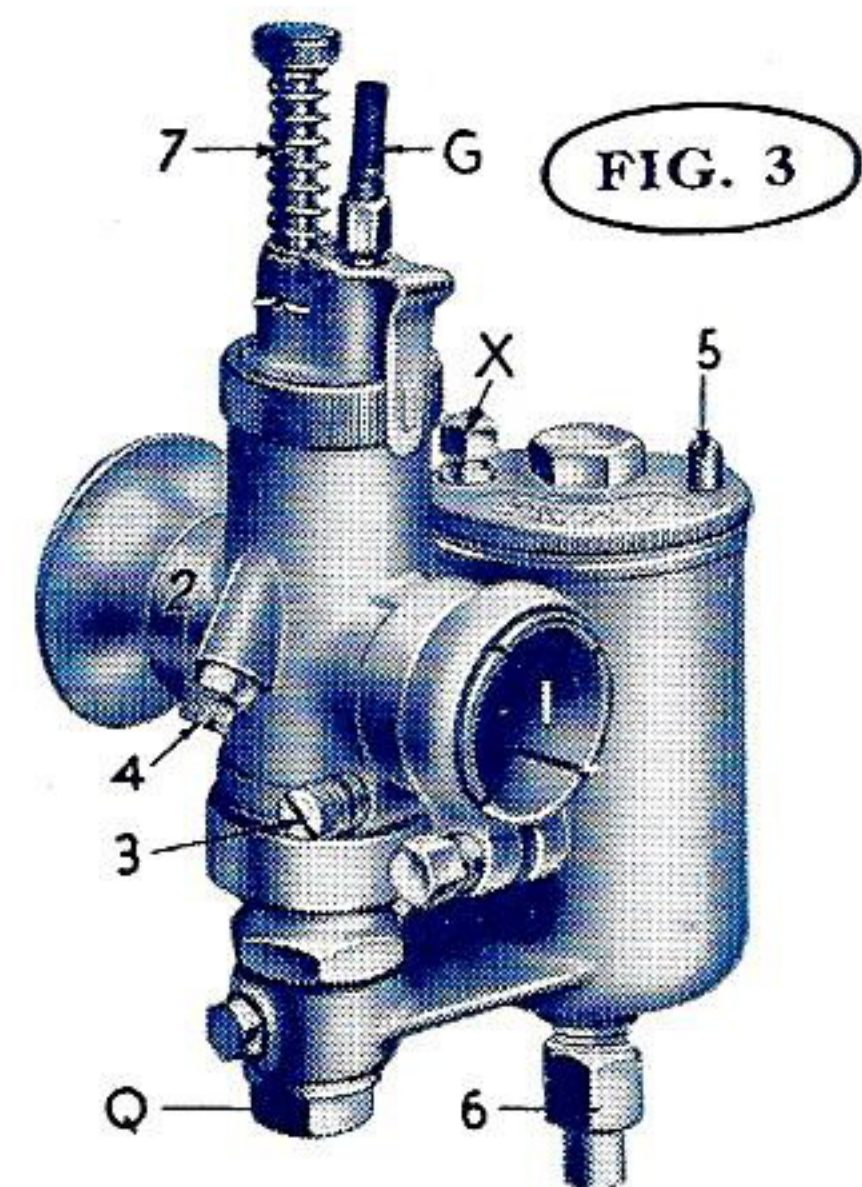

**Vertical Model.
Single Control from Handlebar and Rod Operated Air Valve.**

- Index to letters on illustrations.**
1. Connected to engine by flange or clip.
 2. Cross bore or choke to be suitable for engine (see guide tables).
 3. Pilot jet adjustment to give good tickover.
 4. Throttle stop screw to keep engine idling.
 5. Tickler in float chamber to facilitate cold starting.
 6. Petrol pipe connection direct or with banjo fitting.
 7. Air valve for easy starting from cold.
 - G. Throttle control cable.
 - G1. Air control cable.
 - X. Lock screw to prevent loss of float chamber lid.
 - Q. Holding bolt (The main jet is located beneath this).

CARBURETTER POSITIONS. Horizontal, Vertical, or Inclined (see Float Chamber Position).

FLOAT CHAMBER POSITIONS. These carburetters have detachable float chambers that can be placed on either side of the mixing chamber when vertical. Detachable float chambers can also be provided for "inclined" mixing chambers, set at angles of 3°, 7°, or 15° from the vertical when either right or left hand is specified.

PETROL FEED CONNECTIONS. Top or bottom feed to the float chamber with single banjo, double banjo or straight in nut and nipple petrol pipe connections.

AIR INTAKE FITTINGS. Plain funnel as illustrated, or 3-gauge intake or air filter (see list 325).

CONTROLS. Double Control from handlebar, rod operated air valve and single control from handlebar.

FIXINGS. Flange or clip fitting as follows:—

Type	Flange position	Flange bolt centres	Clip fitting to pipe	Type	Flange position	Flange bolt centres	Clip fitting to pipe
274 275	Hor. or Vert. Hor. or Vert.	2" or 40 mm. 2" centres.	1" and 7/8" outside dia. 1 1/4" and 1" outside dia.	276 289	Hor. or Vert. Hor. or Vert.	2" centres. 2" centres.	1 1/4" and 1 1/4" outside dia. 1 1/4" outside dia.

GUIDE TO CARBURETTER SELECTION FOR:—

SINGLE CYLINDER ENGINES		Carburettor		SINGLE CYLINDER ENGINES		Carburettor		TWIN CYLINDER ENGINES		Carburettor											
Type	Cross bore	Type	Cross bore	Type	Cross bore	Type	Cross bore	Type	Cross bore	Type	Cross bore										
No.	inch	No.	inch	No.	inch	No.	inch	No.	inch	No.	inch										
	m/m.		m/m.		m/m.		m/m.		m/m.		m/m.										
175 c.c.	TOURING 2-Stroke	274	21/32	16.7	350 c.c.	TOURING 2-Stroke	275	7/8	22.2	350 c.c.	TOURING S.V.	274	25/32	19.3							
	TOURING S.V.	274	25/32	16.7		TOURING S.V.	274	13/16	20.6		SPORTS O.H.V.	274	25/32	19.8							
	TOURING O.H.V.	274	25/32	18.3		SPORTS O.H.V.	276	1	25.4		TOURING S.V.	274	25/32	18.3							
	SPORTS O.H.V.	274	25/32	19.8		TOURING S.V.	276	15/16	23.8		TOURING O.H.V.	274	25/32	19.8							
250 c.c.	TOURING 2-Stroke	274	25/32	19.8	600 c.c.	TOURING O.H.V.	276	1 1/16	27	1000 c.c.	SPORTS O.H.V.	275	13/16	20.6							
	TOURING S.V.	274	25/32	18.3		SPORTS	289	1 3/32	27.8		SCOTT 2-Stroke 206/151R	1 1/16	27								
	TOURING O.H.V.	274	25/32	19.8		TOURING	276	1	25.4		TOURING S.V.	276	15/16	23.8							
	SPORTS O.H.V.	275	13/16	20.6		SEE SETTINGS LISTS 440 FOR PARTICULAR ENGINES.					TOURING O.H.V.	276	1 1/16	27							

HOW THE CARBURETTER WORKS.

The carburetter proportions and atomises the right amount of petrol with the air that is drawn in by the engine because of the correct proportions of jet sizes and the main choke or cross bore. The float chamber maintains a constant level of fuel at the jets and cuts off the supply when the engine stops. The throttle control from the handlebar controls the volume of mixture and therefore the power, and at all positions of the throttle the mixture is automatically correct. The opening of the throttle brings first into action the mixture supply from the pilot jet system for idling (M), then as it progressively opens, via the pilot by-pass (N), the mixture is augmented from the main jet (P), the earlier stages of which action is controlled by the needle (C) in the needle jet (O). The main jet does not spray directly into the mixing chamber, but discharges through the needle jet into the primary air chamber, and goes from there as a rich petrol-air mixture through the primary air choke into the main air choke or cross bore. This primary air choke has a compensating action. The carburetters usually have a separately-operated mixture control called an air valve (D), for use when starting from cold, and until the engine is warm; this control partially blocks the passage of air through the main choke or cross bore. This design of carburetter offers perfectly simple and effective tuning facilities.

INDEX TO ILLUSTRATION IN SECTION.

- | | | |
|-------------------------------|-----------------------------|-------------------------------------|
| A. Mixing Chamber. | L. Pilot Air Passage. | V. Float Needle Clip |
| B. Throttle Valve. | M. Pilot Mixture Outlet. | W. Float Chamber Cover. |
| C. Jet Needle and Clip above. | N. Pilot By-pass. | X. Float Chamber Lock |
| D. Air Valve. | O. Needle Jet. | Y. Mixing Chamber Top |
| E. Mixing Chamber Union Nut. | P. Main Jet. | Screw (Tickler to left of W). |
| F. Jet Block. | Q. Float Chamber Hold-Bolt. | Y. Mixing Chamber Top Cap. |
| G. Cable Adjusters. | R. Float Chamber. | Z. Mixing Chamber Lock Ring. |
| H. Jet Block Barrel. | S. Needle Seating. | Z1. Mixing Chamber Top Lock Spring. |
| J. Pilot Jet. | T. Float. | |
| K. Passage to Pilot. | U. Float Needle Valve. | |

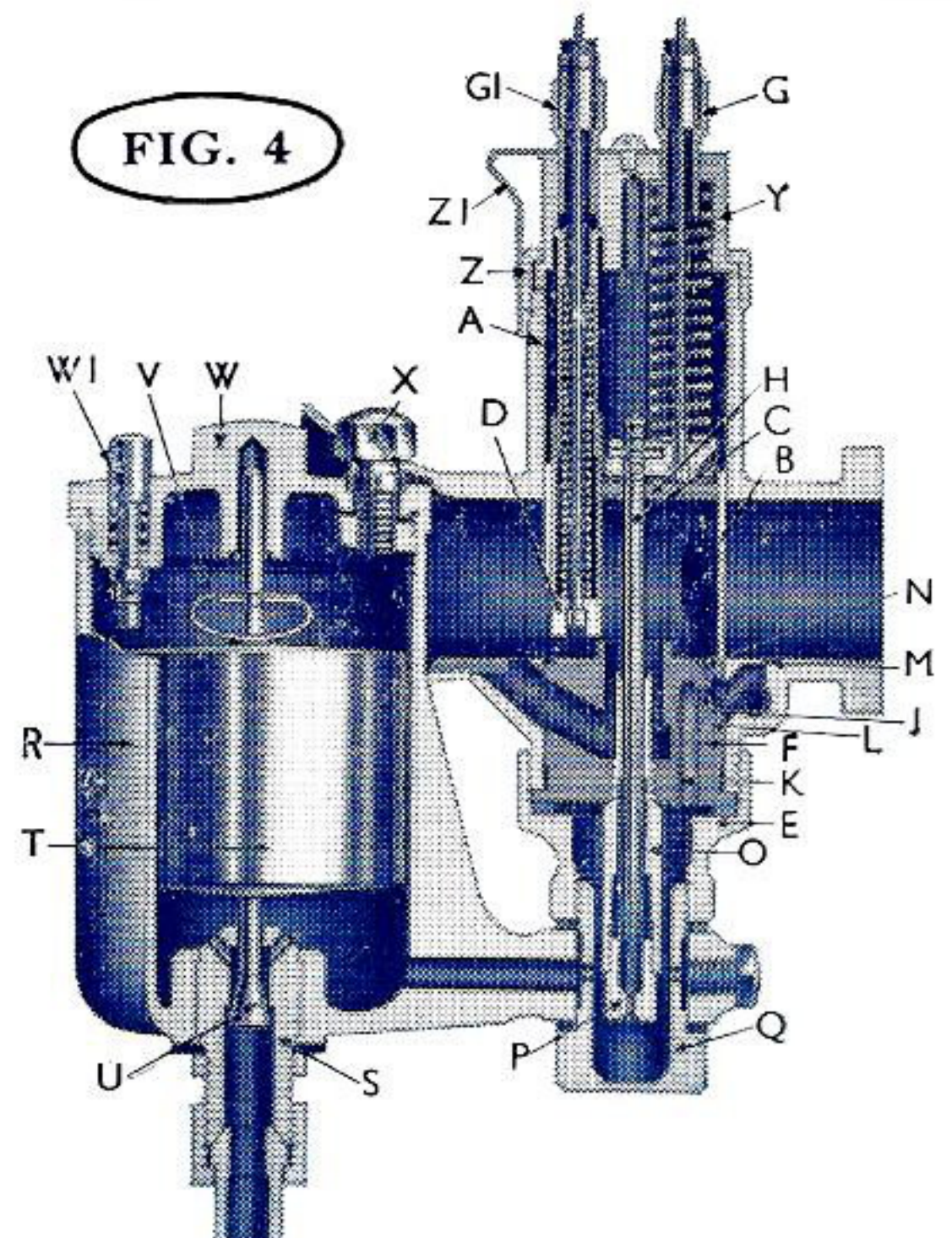

Single Control Carburetters with Needle Jet but WITHOUT Pilot Jet

For Auto-cycles & Small Engines

For Cycle Auxiliary Engines see List Nos. 456 and 515.

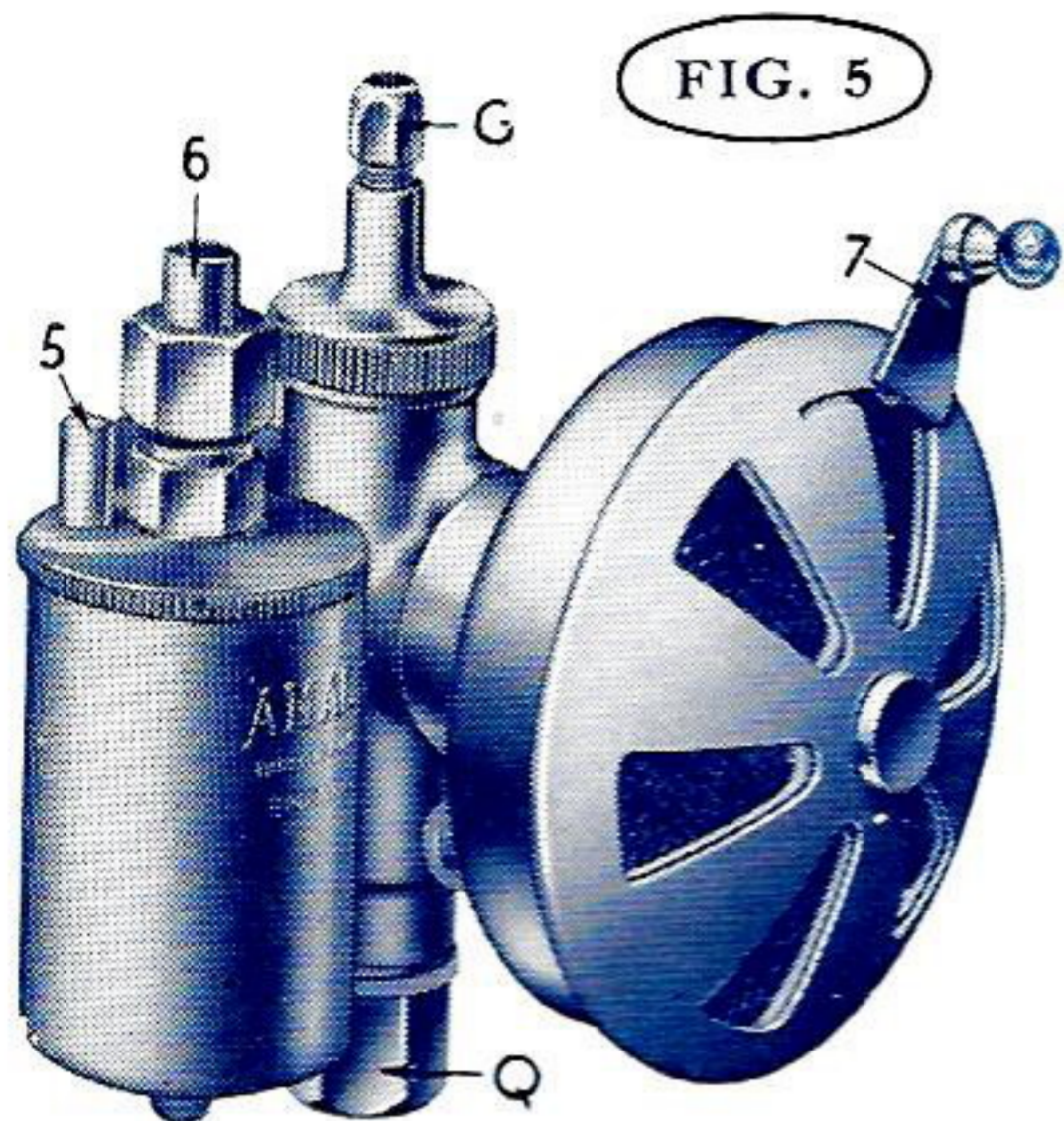

Model with air filter and strangler, and float chamber on left.

The latest float chamber lids are now secured by two screws (except type 223).

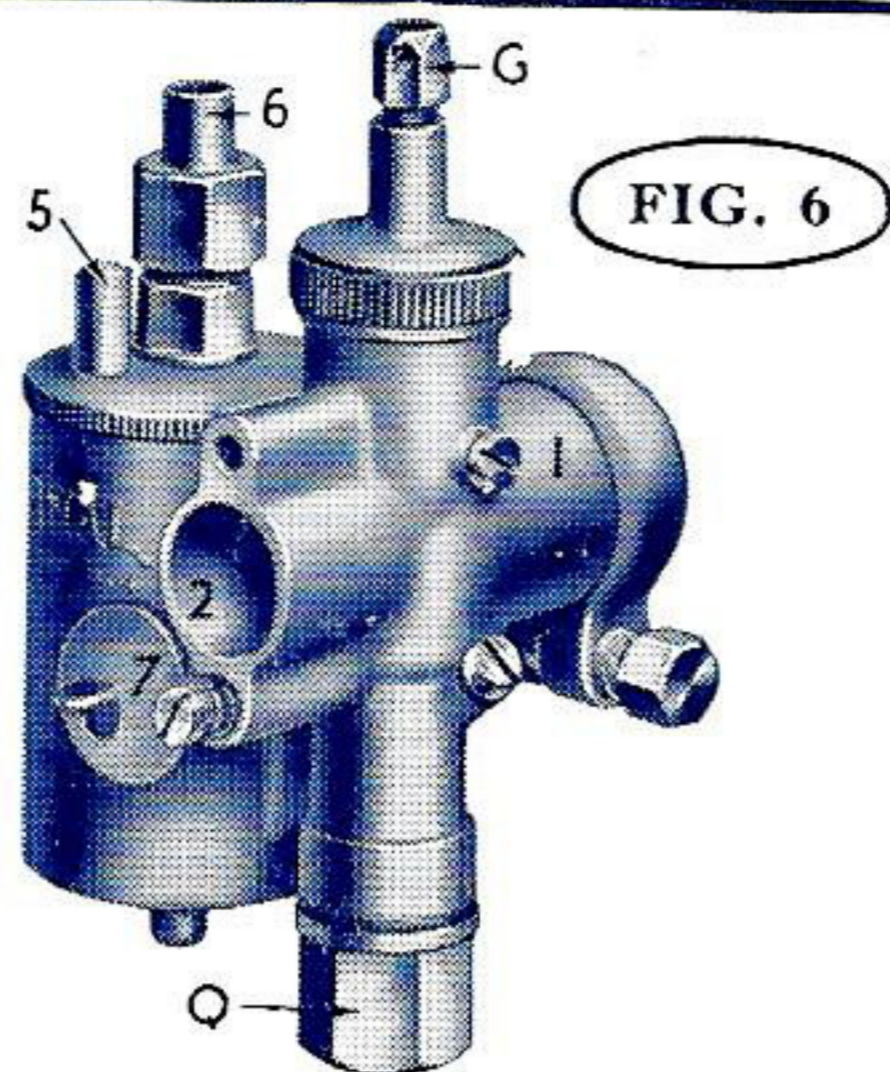

Model with strangler and float chamber on left.

- Index to letters on illustrations.**
1. Connected to engine by flange or clip.
 2. Cross bore or choke to be suitable for engine (see guide table).
 5. Tickler in float chamber to facilitate cold starting.
 6. Petrol pipe connection direct or with banjo fitting.
 7. Strangler for easy starting from cold.
 - G. Throttle control cable.
 - Q. Jet plug underneath, which the main jet is located.

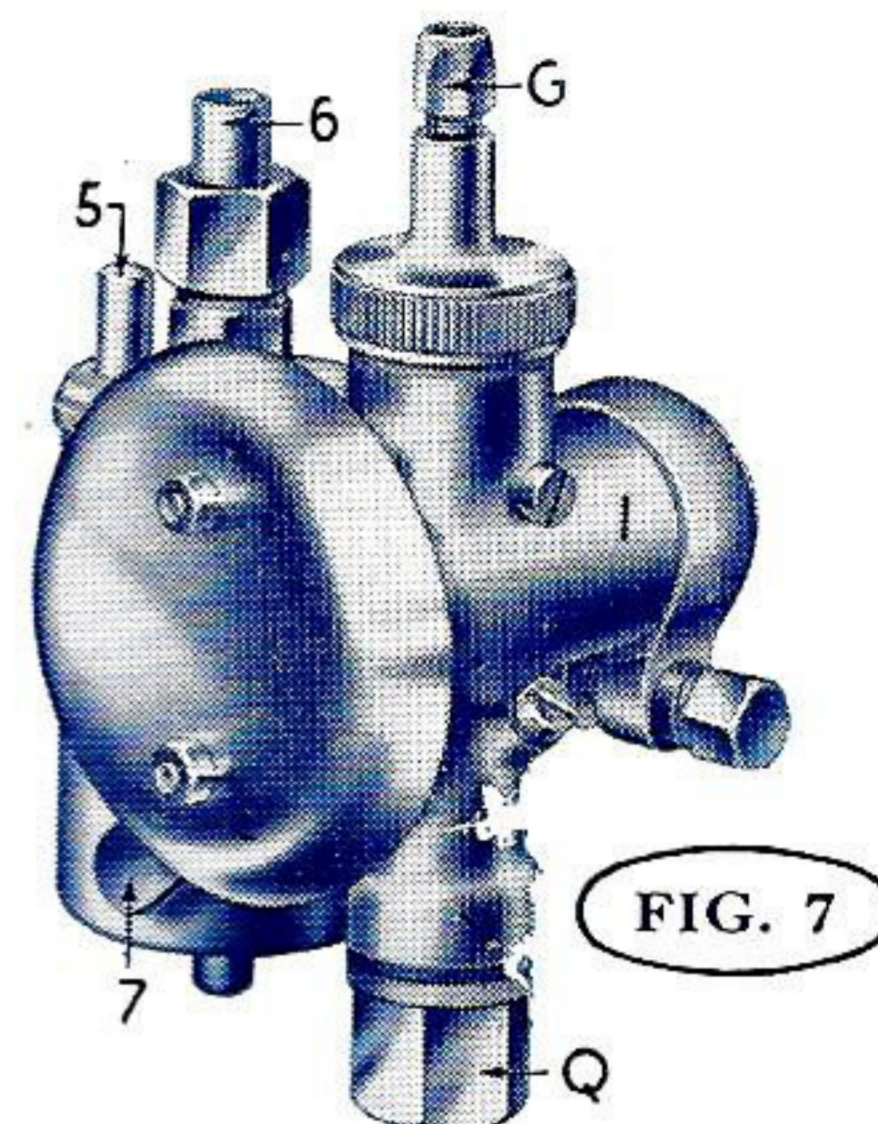

Model with blowback cap and air strangler and float chamber on left.

CARBURETTER POSITION. Vertical only, as illustrated.

FLOAT CHAMBER POSITIONS. Type 359 and 361 right or left hand (looking into intake). Type 223 left hand if clip fitting, right hand if flange fitting, see "Fixing", below.

PETROL FEED CONNECTIONS. Top feed to float chamber by horizontal banjo or straight-in nut and nipple petrol pipe connections.

AIR INTAKE FITTINGS. Type 359 and 361 can be supplied with a strangler (as fig. 6), or a gauze intake (not illustrated) with or without strangler, or a blowback plate (as fig. 7) with or without strangler, or an air filter and strangler (as fig. 5). Type 223 can be supplied with or without an air filter (as fig. 5) only.

CONTROLS. By single lever from handlebar.

FIXING. Type 359 is clip fitting suitable for a 3/4" outside diameter attachment pipe, and Type 361 for a 1" outside diameter attachment pipe. Type 223 can be had with a clip fitting suitable for a 1" outside diameter attachment pipe or a flange fitting to suit two 1/4" diameter studs at 1.574" centres. (See Float Chamber Positions, *re* Type 223, above).

GUIDE TO CARBURETTER SELECTION FOR:—

2-Stroke Engines : c.c. capacity of engine	55	40	90	70	150	100	150	100	140	225	170	250	175			
4-Stroke Engines : c.c. capacity of engine																
NOTE.—Engines that have a higher number than 3000 r.p.m. require larger cross bores than indicated. See page 2.	Cross Bore Illustration Ref. 2		inch m/m.		inch m/m.		inch m/m.		inch m/m.		inch m/m.		inch m/m.			
	3 7/8 10.7		1 5/8 11.9		1 7/8 13.5		1 7/8 13.5		5/8 15.9		3 1/2 16.7		1 1/8 17.5			
	Carburetter Type						359 to fit pipes 3/4" dia., 19 m/m.						361 to fit pipes 1" dia., 25.4 m/m.		223, 1" dia pipes	

HOW THE CARBURETTER WORKS. See Figure 8.

The carburetter is designed to suit small engines and to eliminate any difficulty arising out of the use of very small jets.

The carburetter atomises the correct amount of petrol with air which is drawn into the engine. A float chamber maintains a constant level of fuel at the jets and cuts off the fuel supply when the engine stops. The float chamber is fitted with a tickler (6) for depressing the float to give a greater supply of petrol for starting when the engine is cold. A strangler on the main air intake provides for air regulation when starting the engine from cold. A throttle valve (15) operated by a cable from the handlebar controls the volume of mixture and, therefore, the engine power. At all openings of the throttle the mixture is automatically correct.

Depression caused by movement of the engine piston causes, via the throttle opening, air to flow into the main air intake and fuel to flow through the needle jet (18) into the cross bore and mix with the incoming air forming a fuel air mixture.

Correct fuel/air proportions for various throttle openings are governed by: **The size of the main jet (21), the jet needle (19), which operating in the needle jet (18) controls the amount of fuel fed at lesser openings. The parallel portion of the jet needle (19) which, on entering the bore of the needle jet (18) and in conjunction with the amount of cutaway on the throttle valve controls the idling mixture.**

INDEX TO ILLUSTRATION OF CARBURETTER IN SECTION FIG. 8.

- | | | |
|------------------------------|------------------------------------|-----------------------|
| 1. Float Needle. | 9. Float Chamber Cover. | 16. Feed Hole Screw. |
| 2. Float. | 10. Cable Adjuster. | 17. Feed Hole Washer. |
| 3. Tickler Cotter. | 11. Mixing Chamber Top. | 18. Needle Jet. |
| 4. Tickler Bush. | 12. Throttle Spring. | 19. Jet Needle. |
| 5. Tickler Spring. | 13. Throttle Valve Location Screw. | 20. Jet Plug Washer. |
| 6. Tickler. | 14. Jet Needle Clip. | 21. Main Jet. |
| 7. Petrol Pipe Union Nipple. | 15. Throttle Valve. | 22. Jet Plug. |
| 8. Petrol Pipe Union Nut. | | 23. Float Chamber. |
- A. Petrol Feed Needle Seat.
 B. Air Vent Hole in Float Chamber Cover.
 C. Air Release Passage from Jet Chamber into Float Chamber.
 D. Petrol Feed Passage from Float Chamber to Main Jet (21).
 E. The illustration shows the float and needle as one piece, but if the needle is separate, the float has a spring bow at this point to hold the needle in a groove.
 F. The cross bore of the Carburetter, the size of which is specified according to engine size and maximum revs.
 G. Drain hole from mixing chamber to liberate any excess petrol due to flooding.
 K. Throttle Wire. K1. Wire Nipple. L. Throttle Wire Cable.

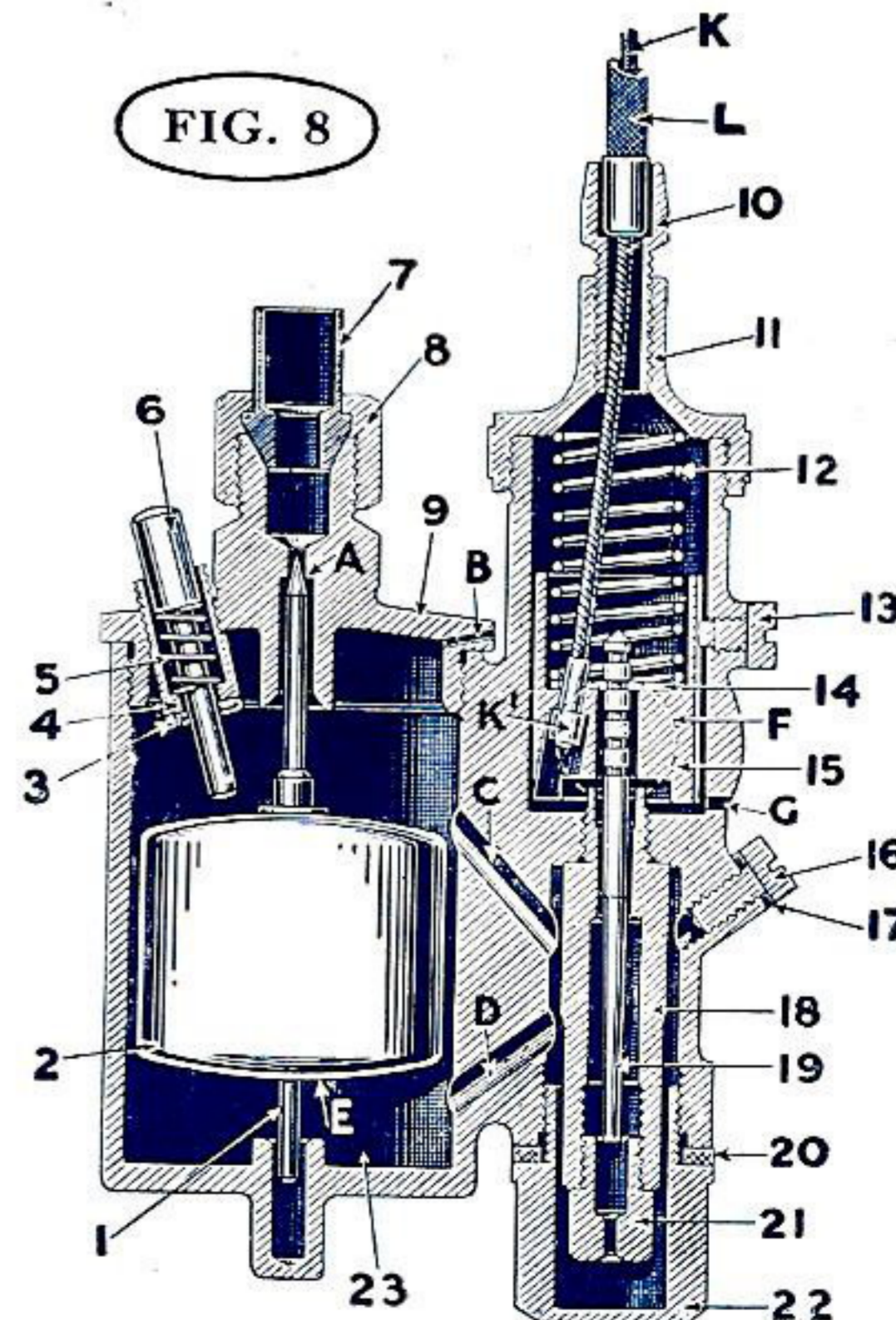

AMAL

PAGE 4

TYPES 352 and 353.

Non-Needle Type. 2-jet model main jet and pilot jet.

For Lightweights and small Marine and Stationary Engines.

FIG. 9

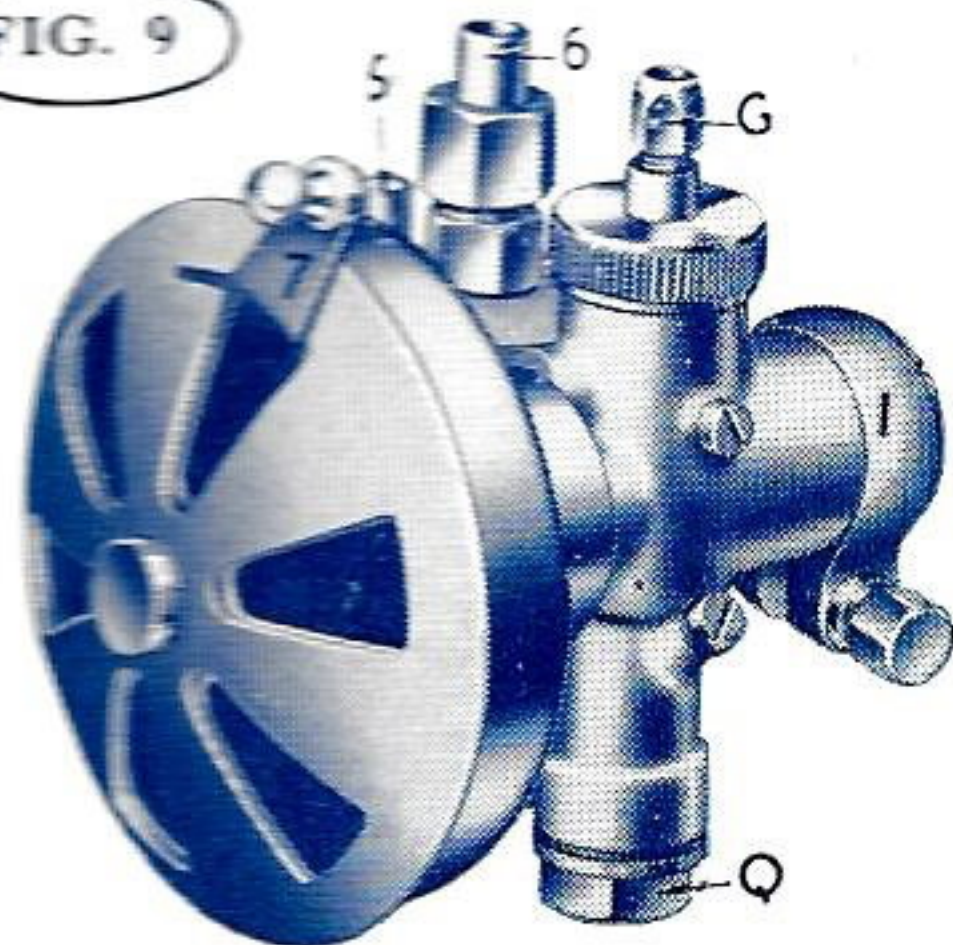

Model with air filter and strangler and float chamber on left.

The latest float chamber lids are now secured by two screws.

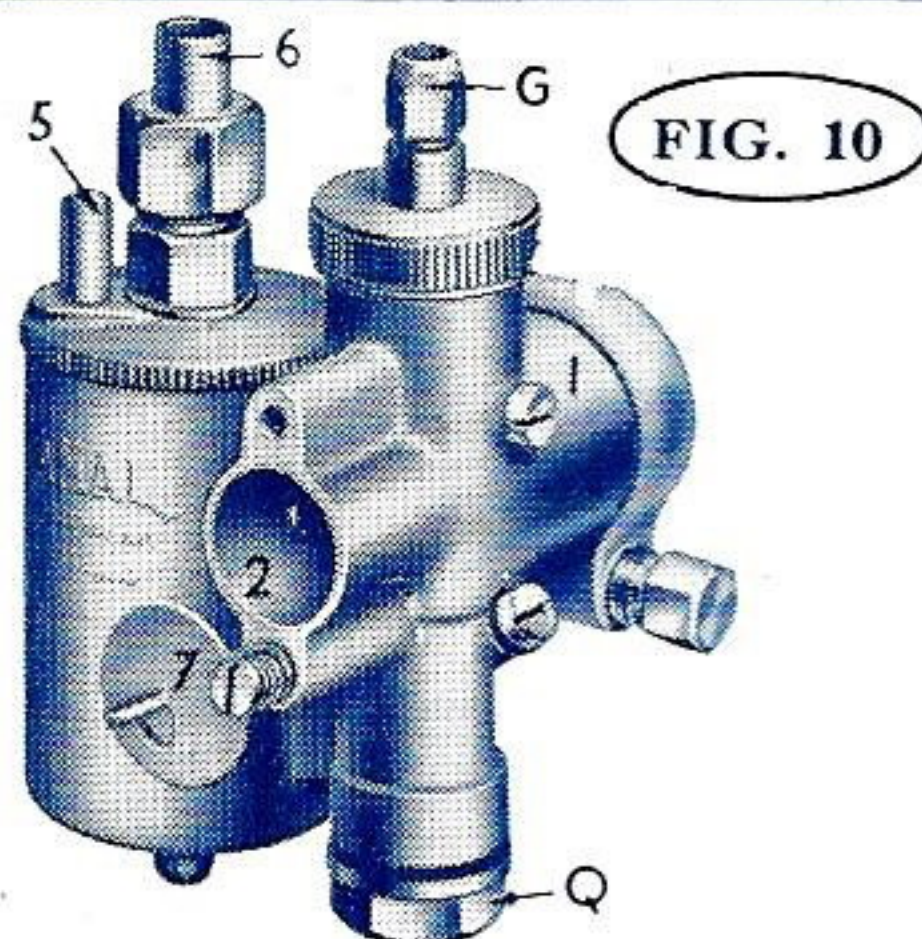

Model with strangler and float cham. on left.

Index to letters on illustrations.

1. Connected to engine by clip or flange.
2. Cross bore or choke to be suitable for engine (see guide table).
5. Tickler in float chamber to facilitate cold starting.
6. Petrol pipe connection direct or with banjo fittings.
7. Strangler for easy starting from cold.
- G. Throttle control cable.
- Q. Jet plug underneath which main jet is located.

FIG. 11

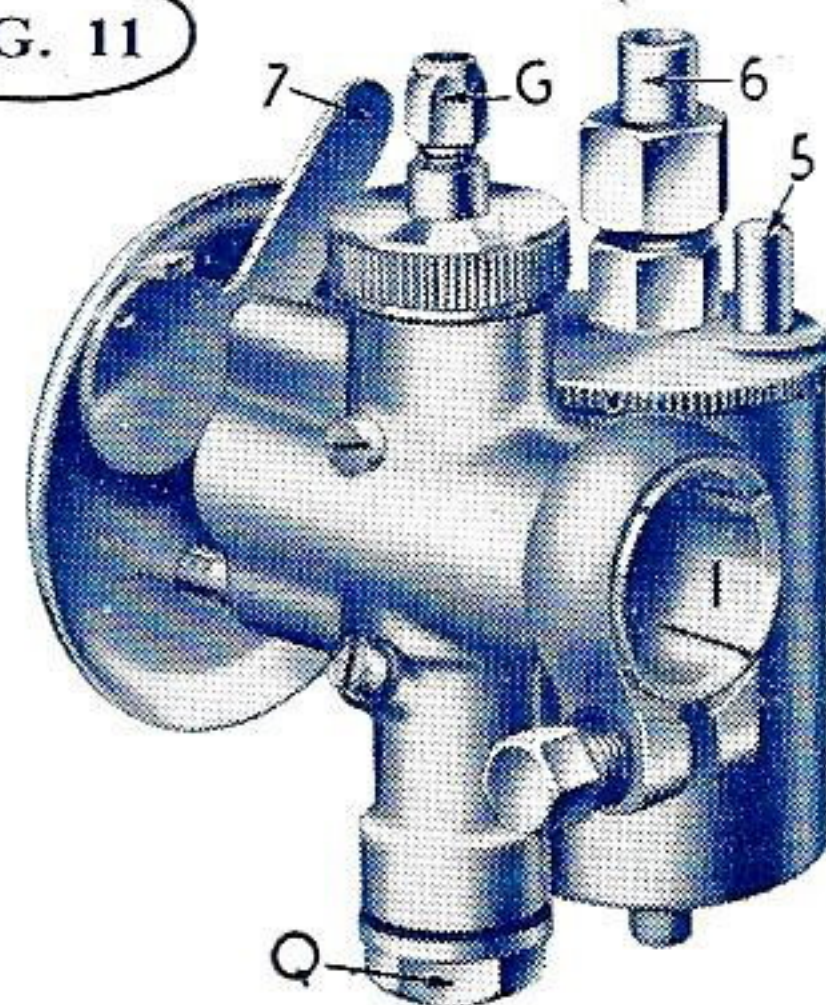

Model with blowback plate and strangler, and float chamber on left.

CARBURETTER POSITIONS. Vertical only, as illustrated.

FLOAT CHAMBER POSITIONS. Right or left hand (looking into air intake).

PETROL FEED CONNECTIONS. Top feed to float chamber by horizontal banjo or straight-in nut and nipple petrol pipe connections.

AIR INTAKE FITTINGS. Can be supplied with a strangler (as fig. 10), or a gauze intake (not illustrated) with or without strangler, or a blowback plate (as fig. 11) with or without strangler, or an air filter and strangler (as fig. 9).

CONTROLS. By single lever from handlebar.

FIXING. Clip fittings, Type 352, is suitable for $\frac{3}{4}$ " outside diameter attachment pipe, and Type 353 for a 1" outside diameter attachment pipe.

GUIDE TO CARBURETTER SELECTION FOR:—

2-Stroke Engines : c.c. capacity of engine	40	70	100	100	140	170	
4-Stroke Engines : c.c. capacity of engine	55	90	150	150	190	225	
NOTE.—Engines that have a higher number than 3000 r.p.m. require larger cross bores than indicated. See page 2.	Cross Bore Illustration Ref. 2	inch m/m. $\frac{27}{64}$ 10.7	inch m/m. $\frac{15}{32}$ 11.9	inch m/m. $\frac{17}{32}$ 13.5	inch m/m. $\frac{17}{32}$ 13.5	inch m/m. $\frac{5}{8}$ 15.9	inch m/m. $\frac{21}{32}$ 16.7
	Carburetter Type	352 to fit pipes $\frac{3}{4}$ " dia., 19 m/m.			353 to fit pipes 1" dia., 25.4 m/m.		

HOW THE CARBURETTER WORKS. See figure 12.

This simple type of two jet instrument meets the requirements of certain engines, for example : certain two stroke and small four stroke engines used on motor cycles and on small stationary and agricultural engines, and also out-board marine engines.

The following points are of note:—

The utmost simplicity in the design and the easy adjustment of two jets makes the carburetter ideal for many purposes. It is operated by a single cable (M).

The petrol feed is always to the top of the float chamber which, in its turn, feeds the jet chamber above cap (H) and maintains a constant level in the jets. The jets have fixed orifices and are numbered according to their flow.

Pilot jet "C" is selected to regulate the mixture strength for slow running and for small throttle openings. The longer jet, namely, the main jet "D" situated near the air intake, comes into action later when un-masked by throttle valve (K) as it is opened, and this jet controls the mixture strength at full throttle : At intermediate throttle positions, viz., between quarter and three-quarter throttle opening, the mixture is determined by the "cut-away" on the air-intake side of the throttle valve.

For starting from cold an air strangler is provided on the intake of the carburetter as (7) in figures 9, 10, 11, above, or described by letter "L" in the sectioned diagram fig. 12. A tickler is provided in the lid of the float chamber for flooding for cold starting.

INDEX FOR FIGURE 12.

- | | | | |
|---------------------|---------------------|-----------------------------|------------------------------------|
| A. Main Air Intake. | D. Main Jet. | K. Throttle. | M. Throttle Cable adjusting screw. |
| C. Pilot Jet. | H. Jet Chamber Cap. | L. Cold Starting Strangler. | |

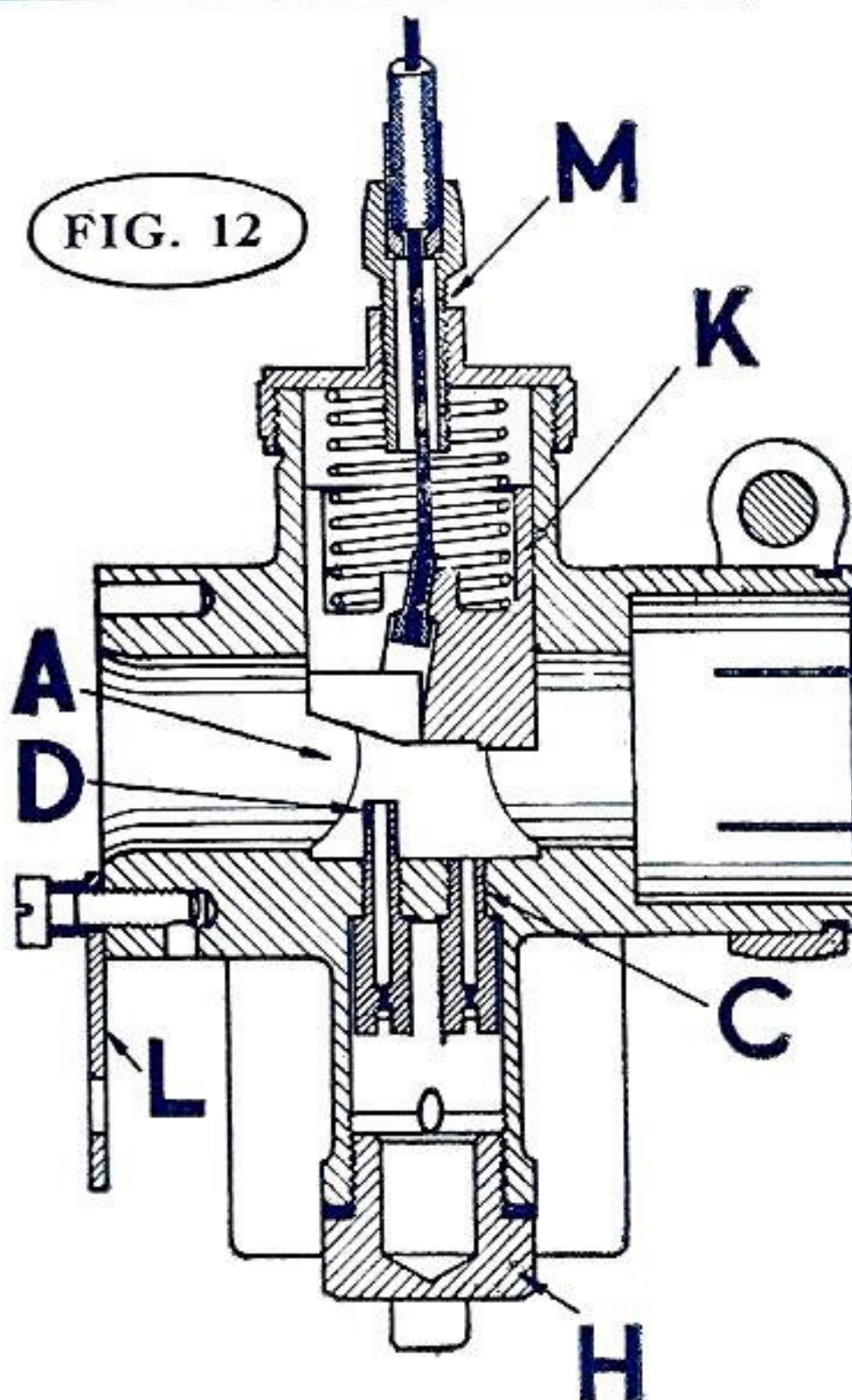

AMAL LTD., HOLDFORD ROAD, WITTON, BIRMINGHAM 6, ENGLAND

Phone : Birmingham, BIRchfields 4571.
(P.B.X. 6 lines)

Telegrams : "AMALCARB, 'PHONE, BIRMINGHAM."