



September, 1958.

LIST No. 560
(ISSUE No. 2)

Spare Parts List

for

Handlebars and Controls

**All illustrations full size
(except Handlebar Assemblies)**

For Prices refer to Supplementary List No. 561

For Twist Grip Parts refer to List No. 521

GUARANTEE.—The Company take all possible reasonable care in the manufacture and the quality of their products. Purchasers are informed that, any part proved to be defective in manufacture or quality, and returned to the works within six months of its purchase new, will be replaced. The Company must respectfully point out however, that its responsibility and that of its agents, stockists and dealers, is limited to this Guarantee, and that they cannot under any circumstances, be held responsible for any loss or for any contingent or resulting liability arising through any defect. These conditions of sale and use also apply when the Company's products form part of the original equipment of machines purchased new.

1000/9/58. W.

Printed in England

**AMAL LTD., HOLDFORD ROAD, WITTON,
BIRMINGHAM 6, ENGLAND**

'Phone : Birmingham, BIRchfields 4571.
(P.B.X. 6 lines)

Telegrams : "AMALCARB, 'PHONE,
BIRMINGHAM."

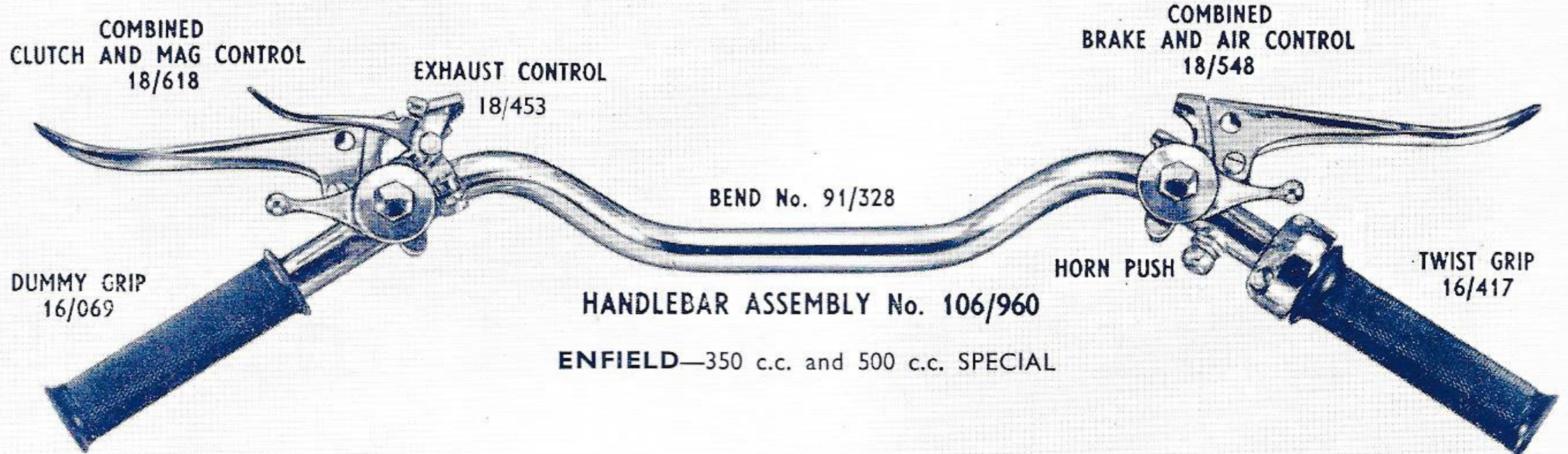
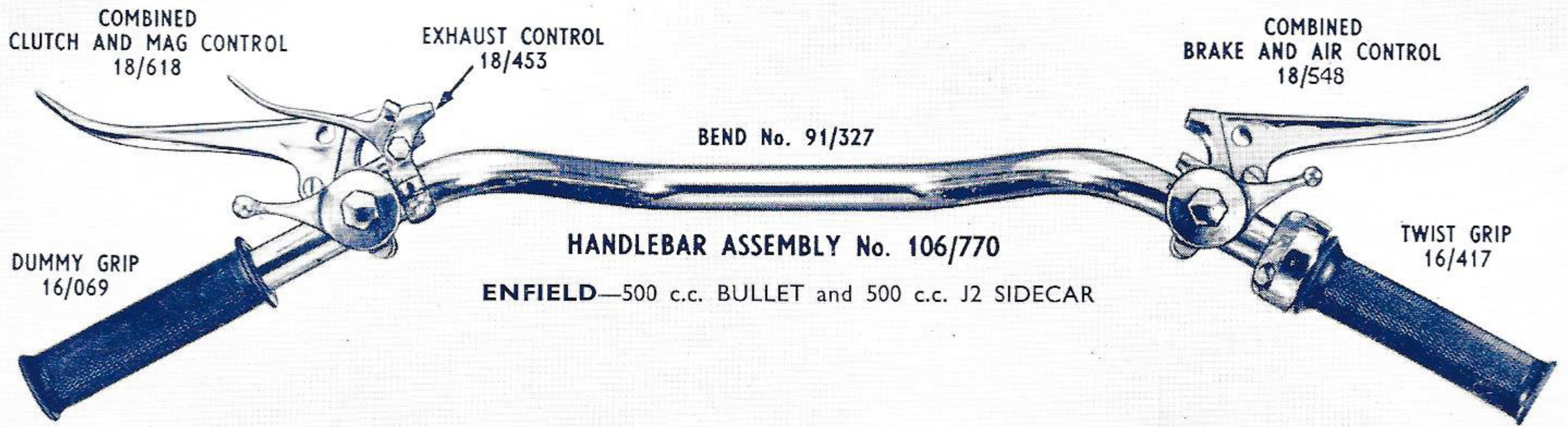

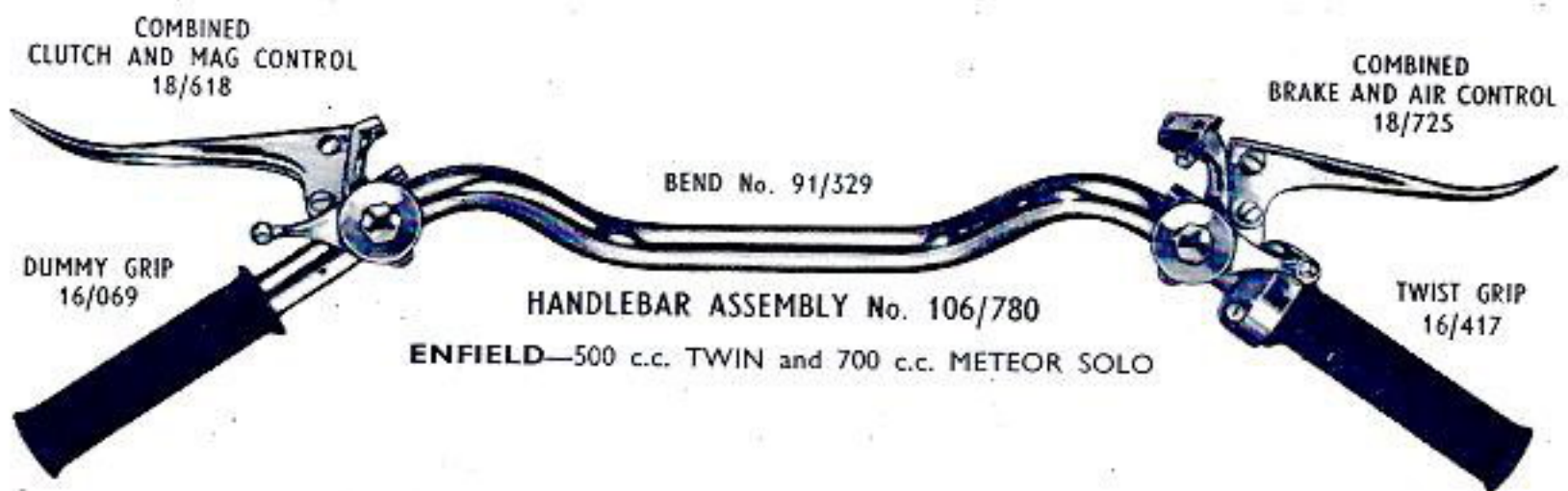
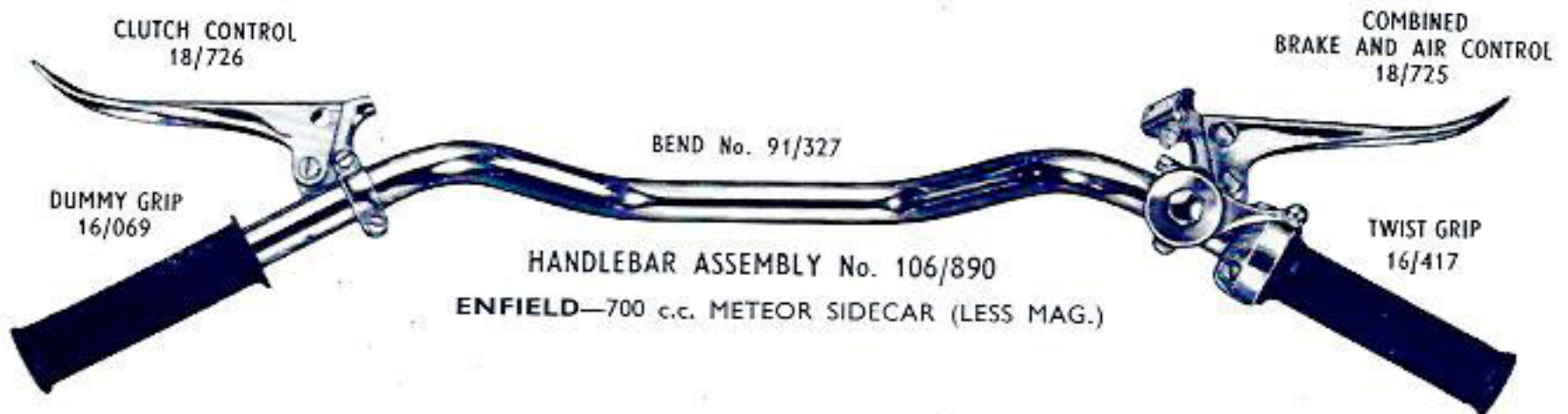

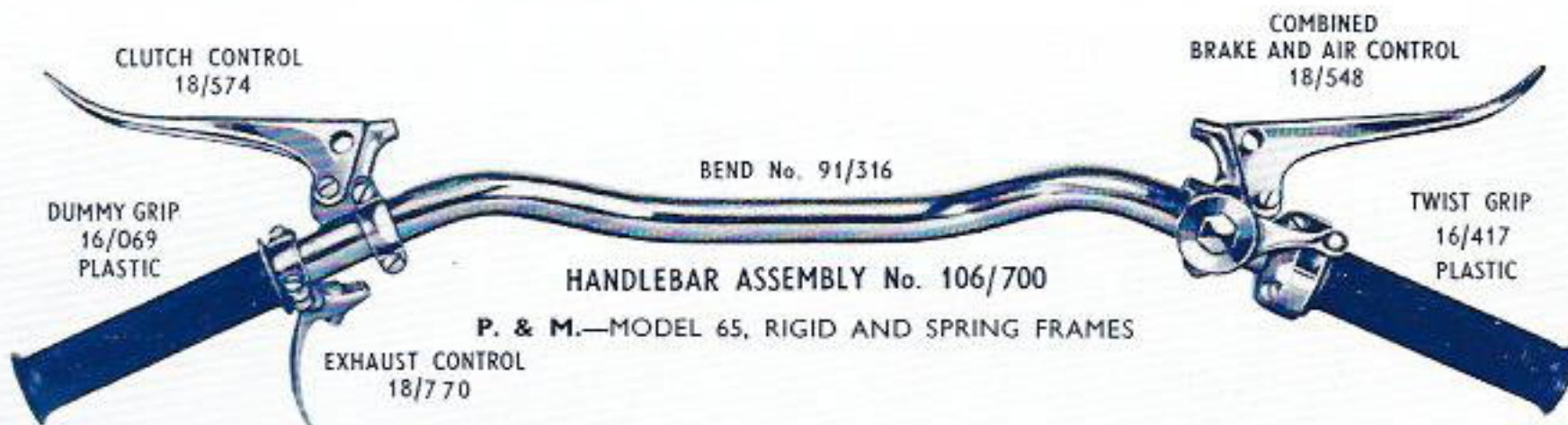
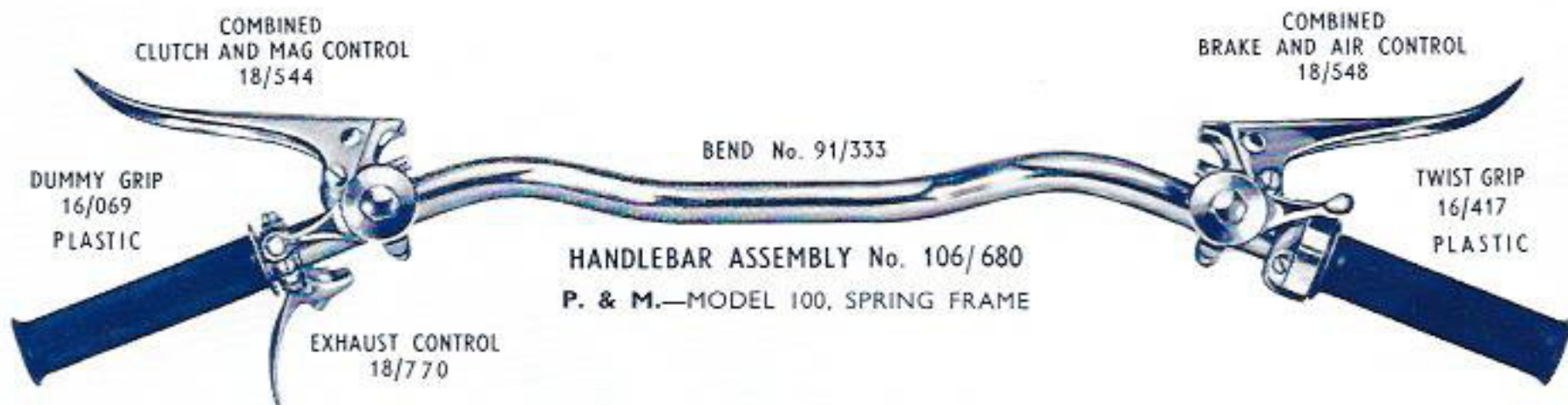
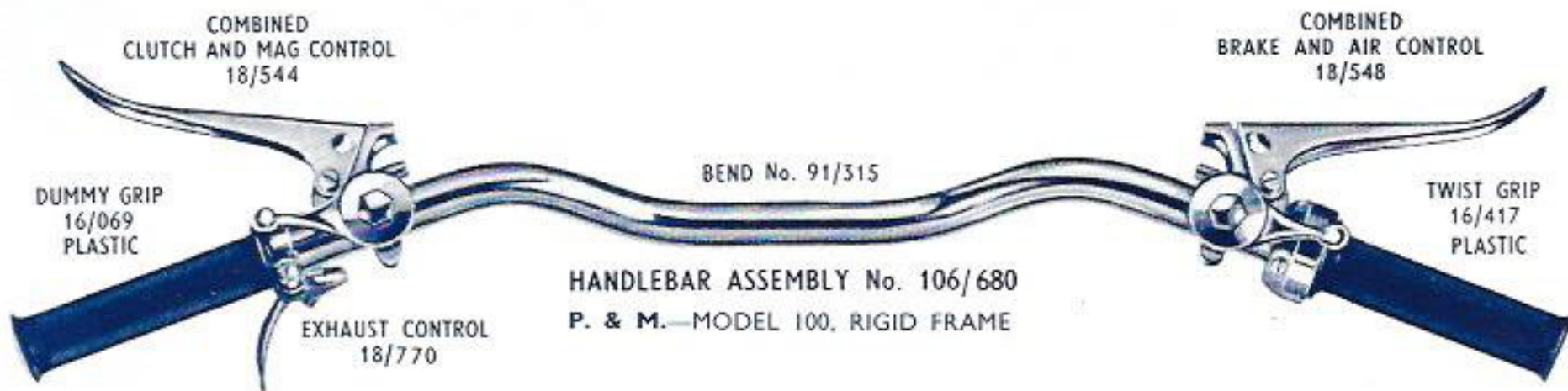
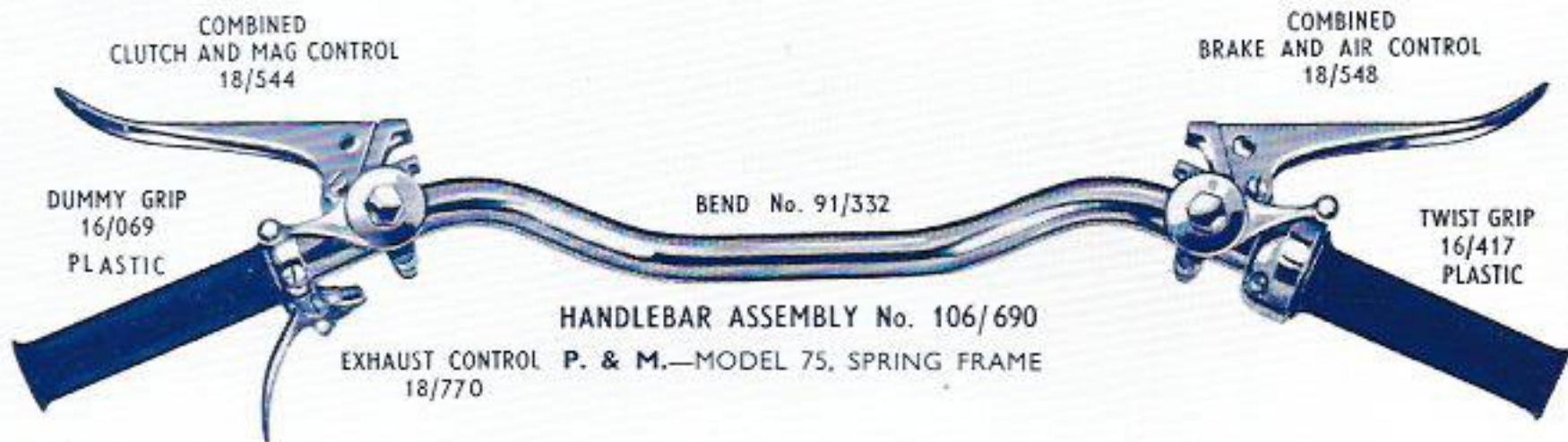

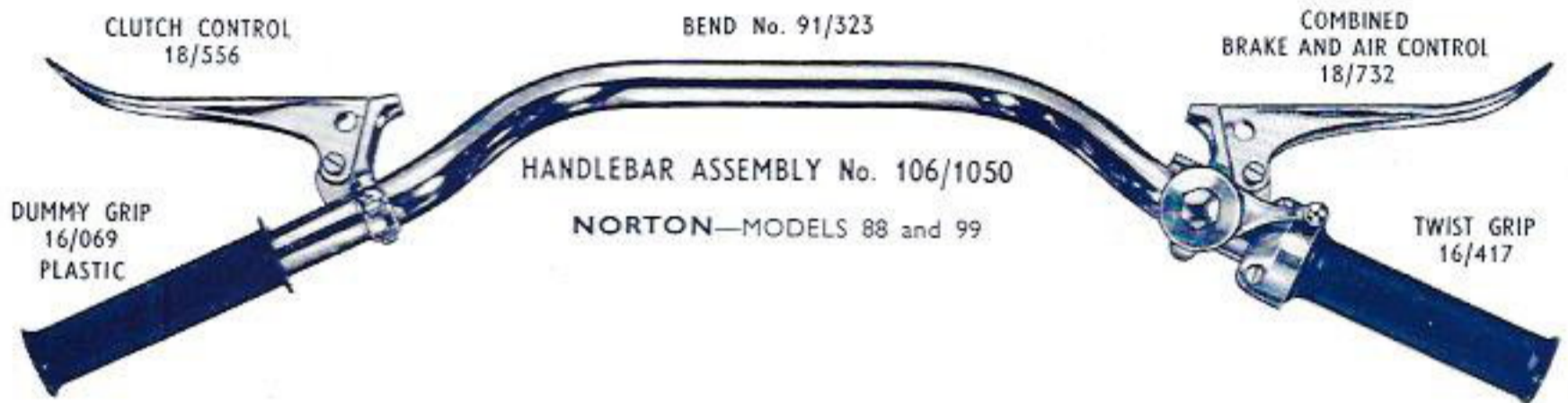

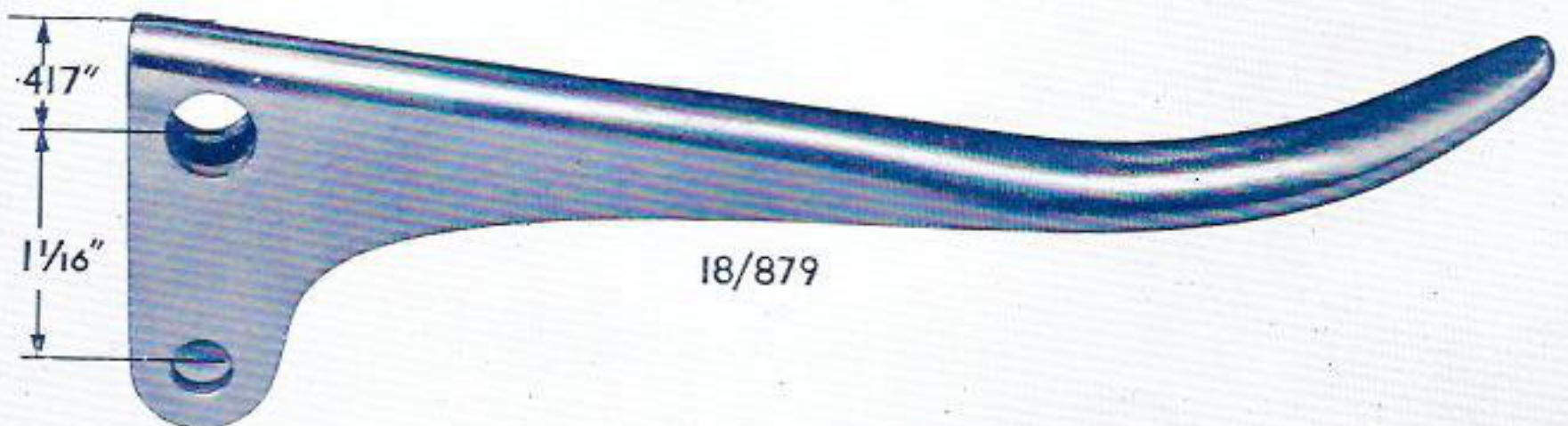
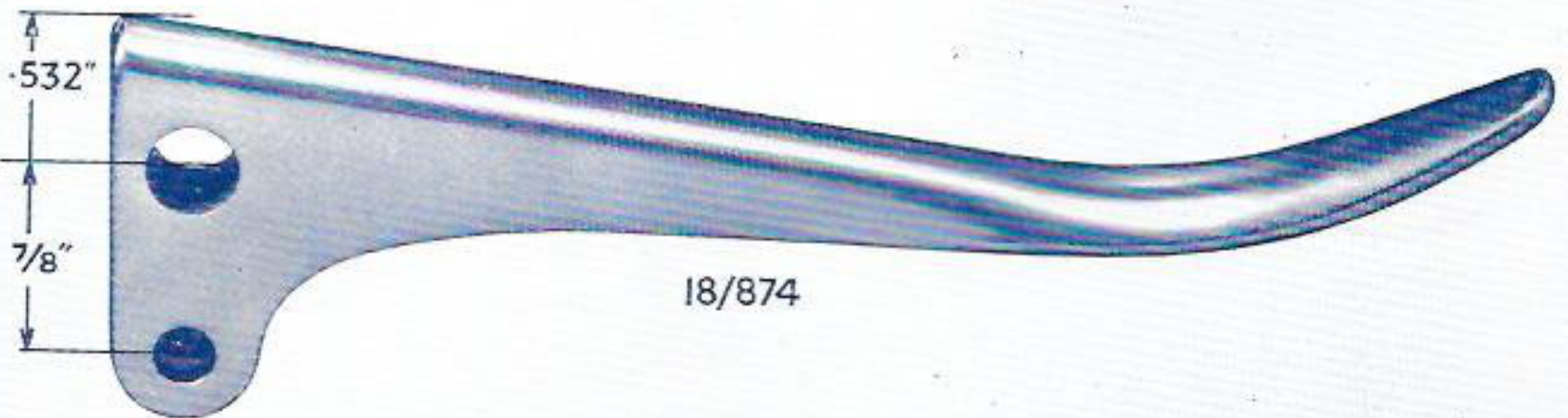

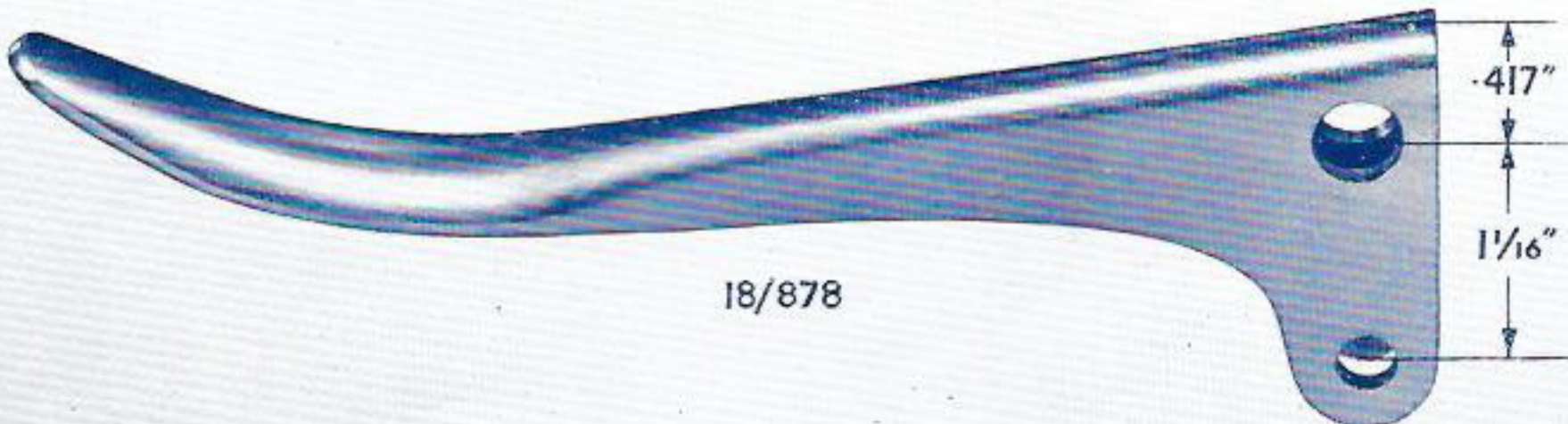
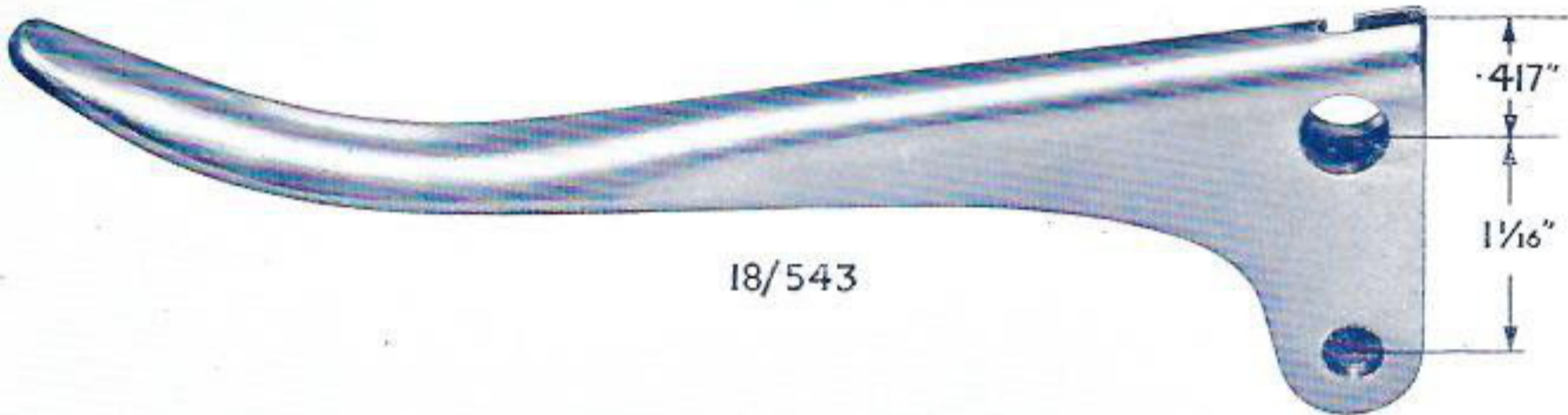
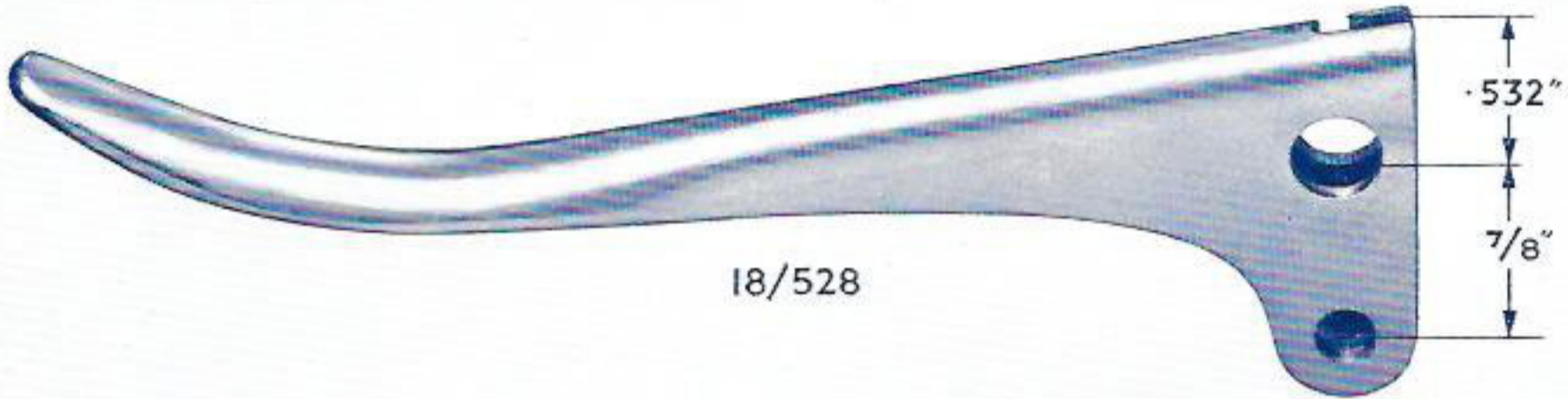
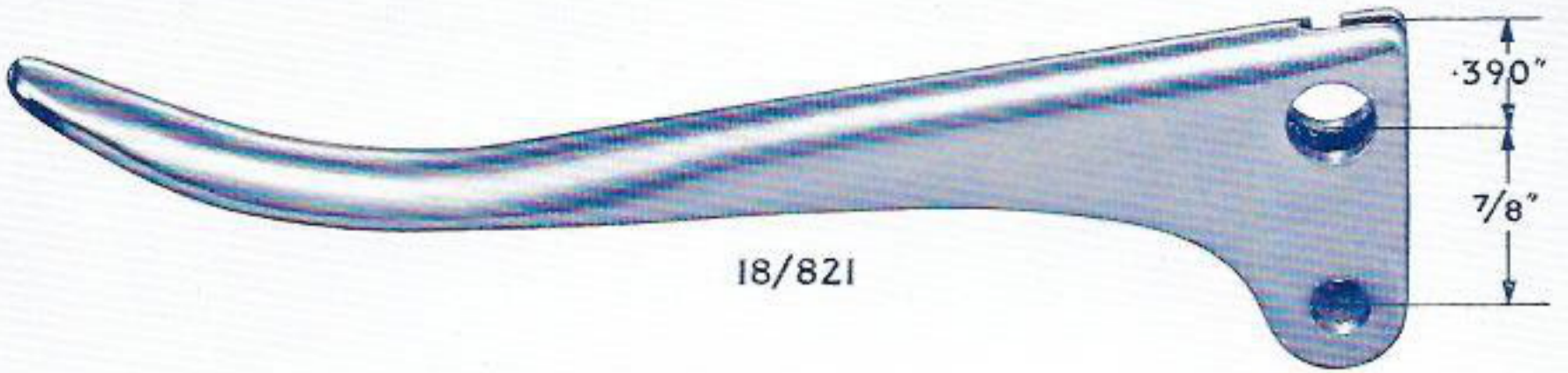

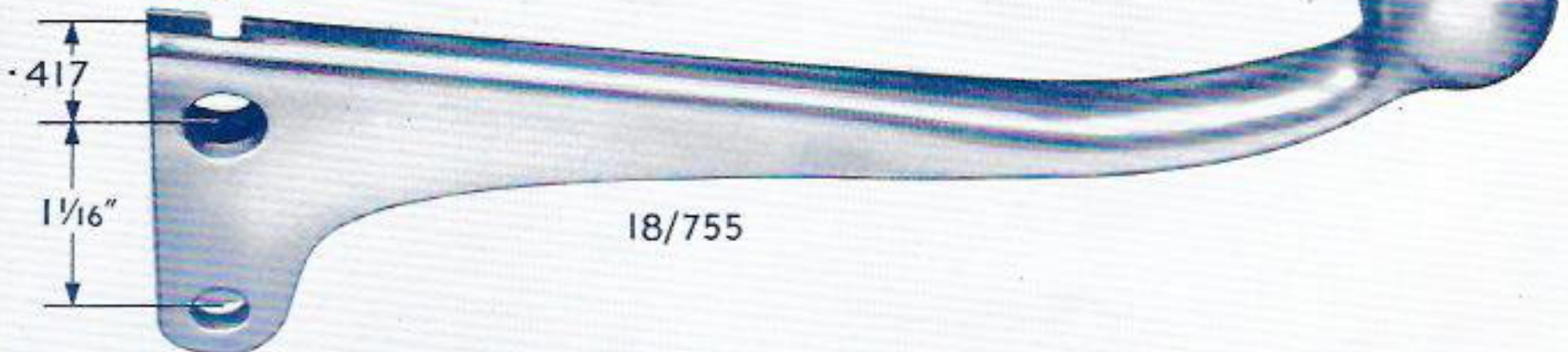
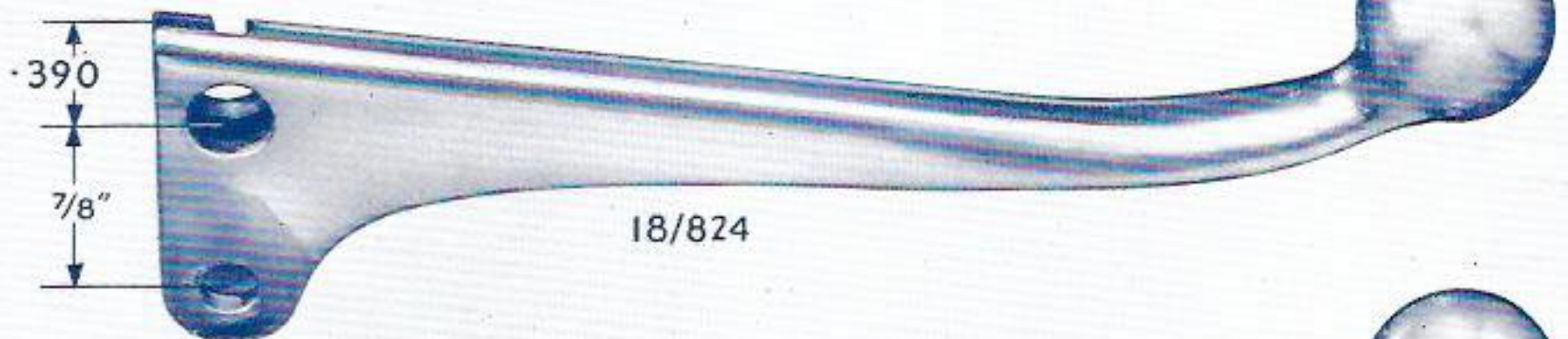
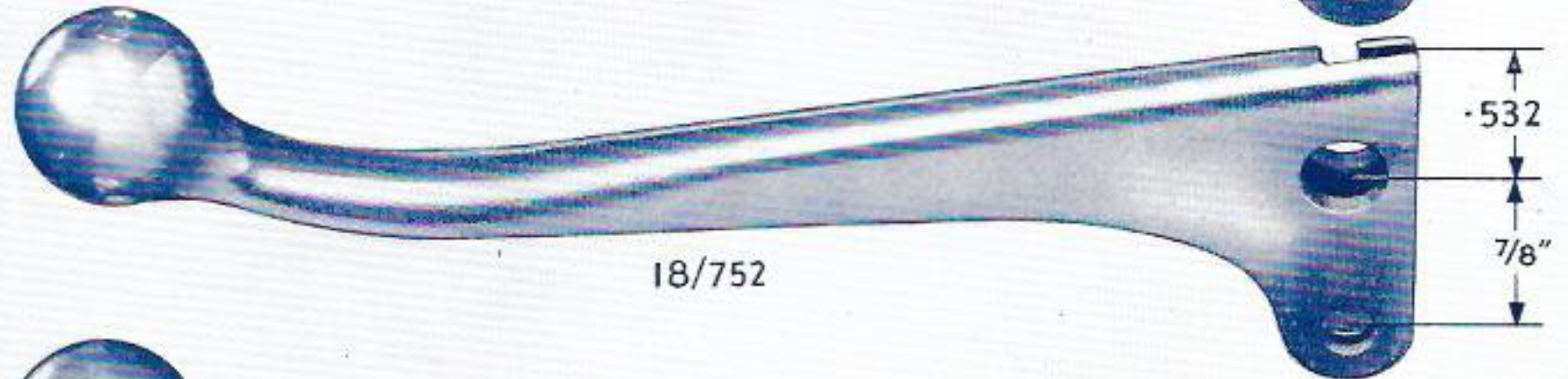
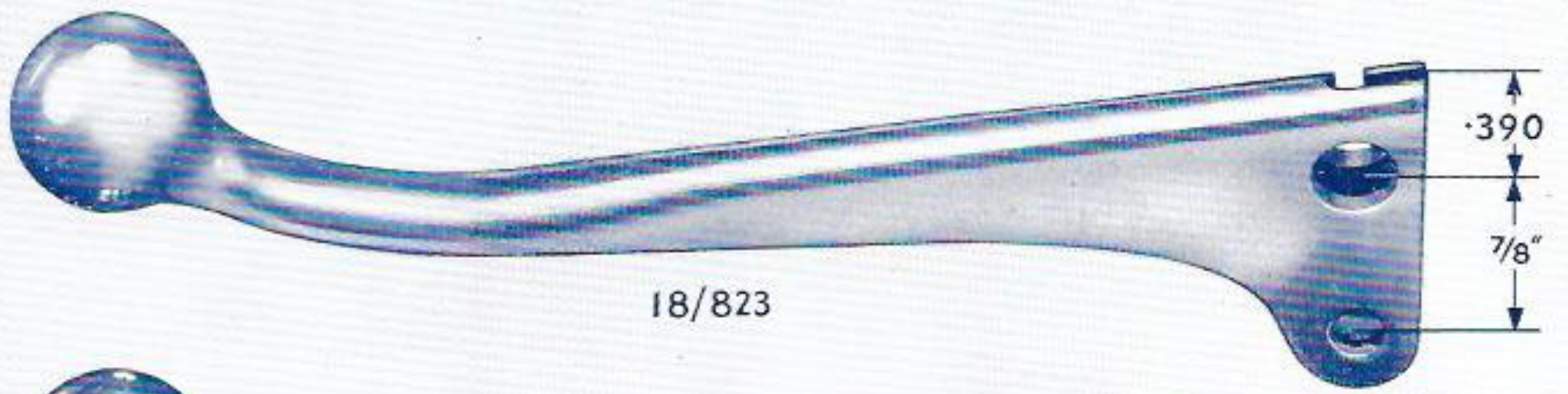

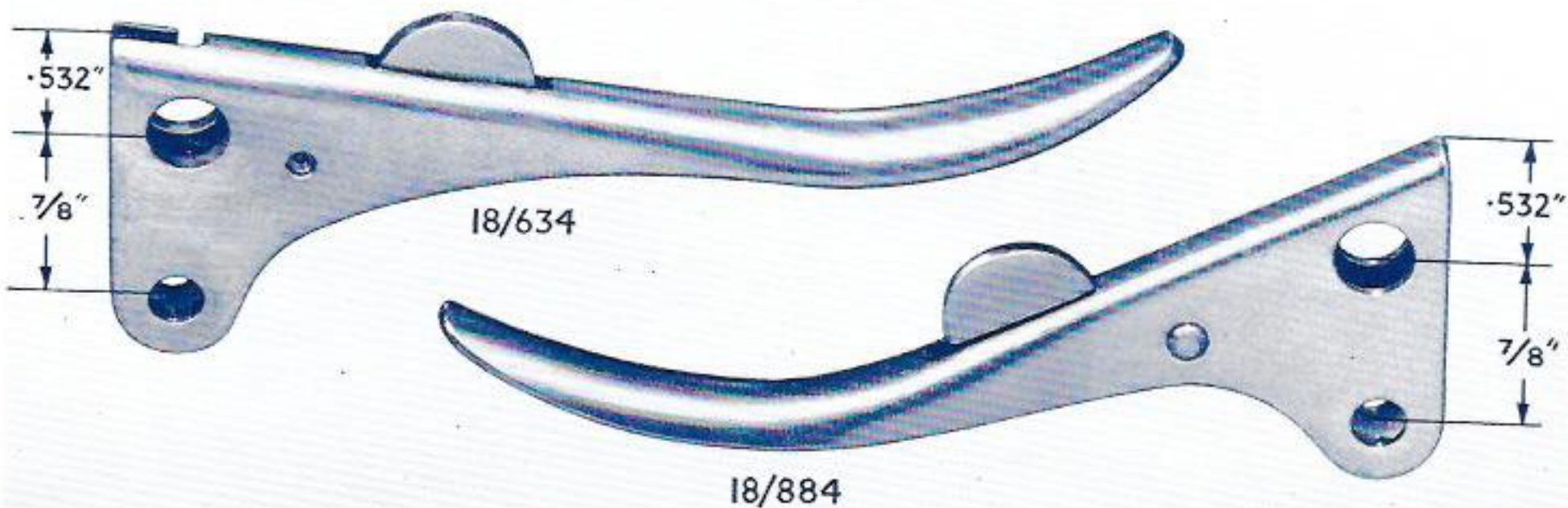
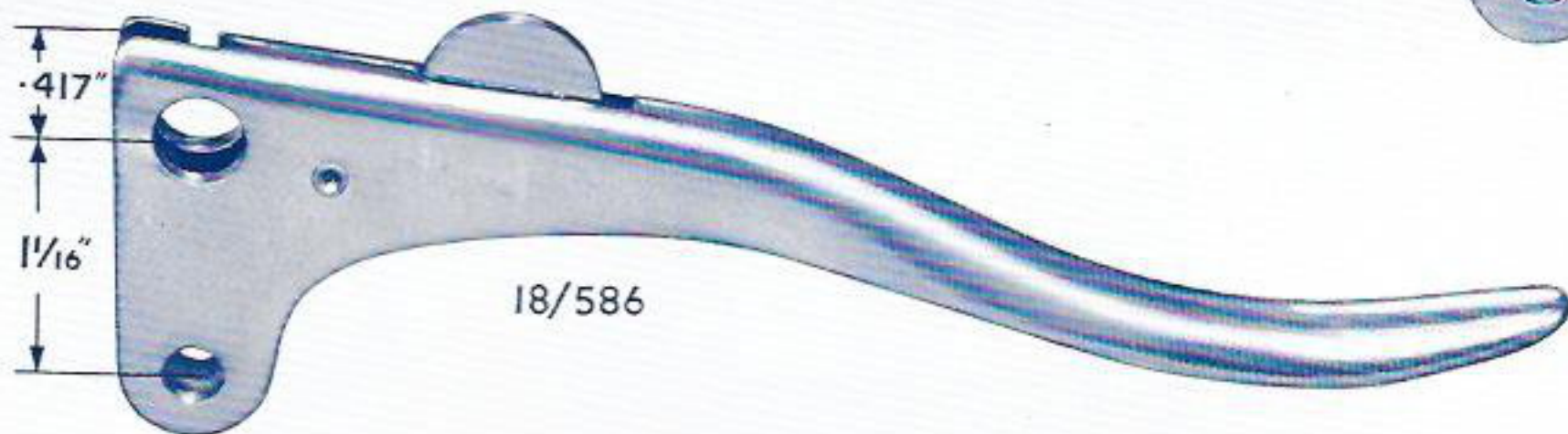

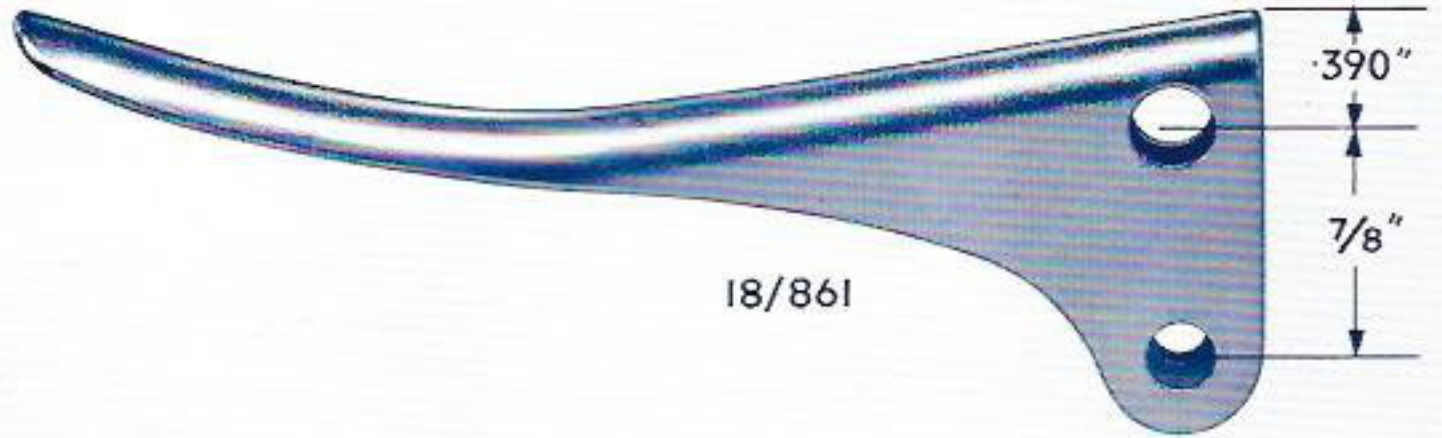
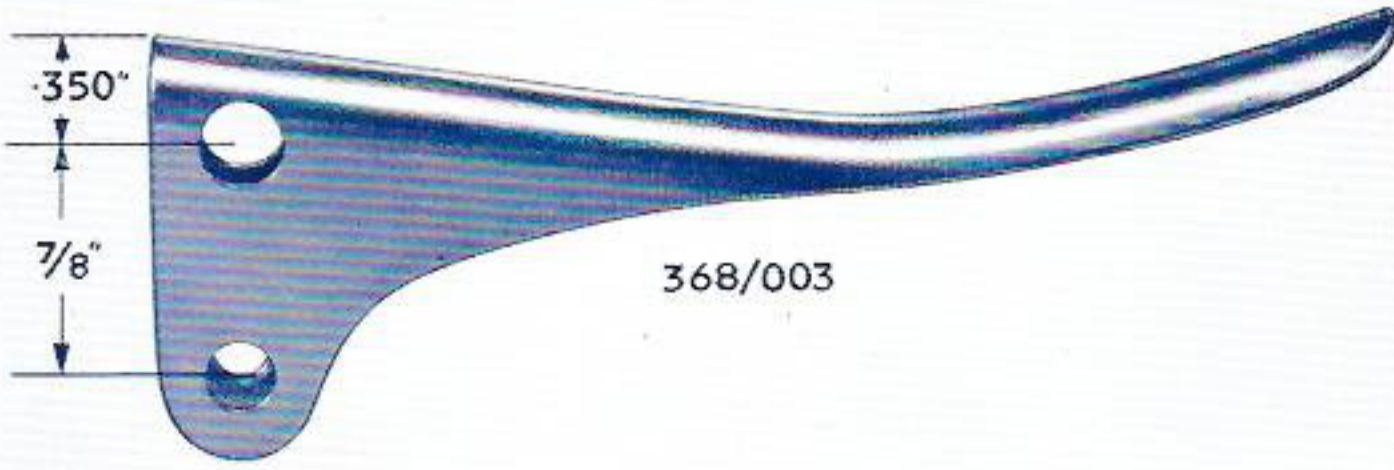



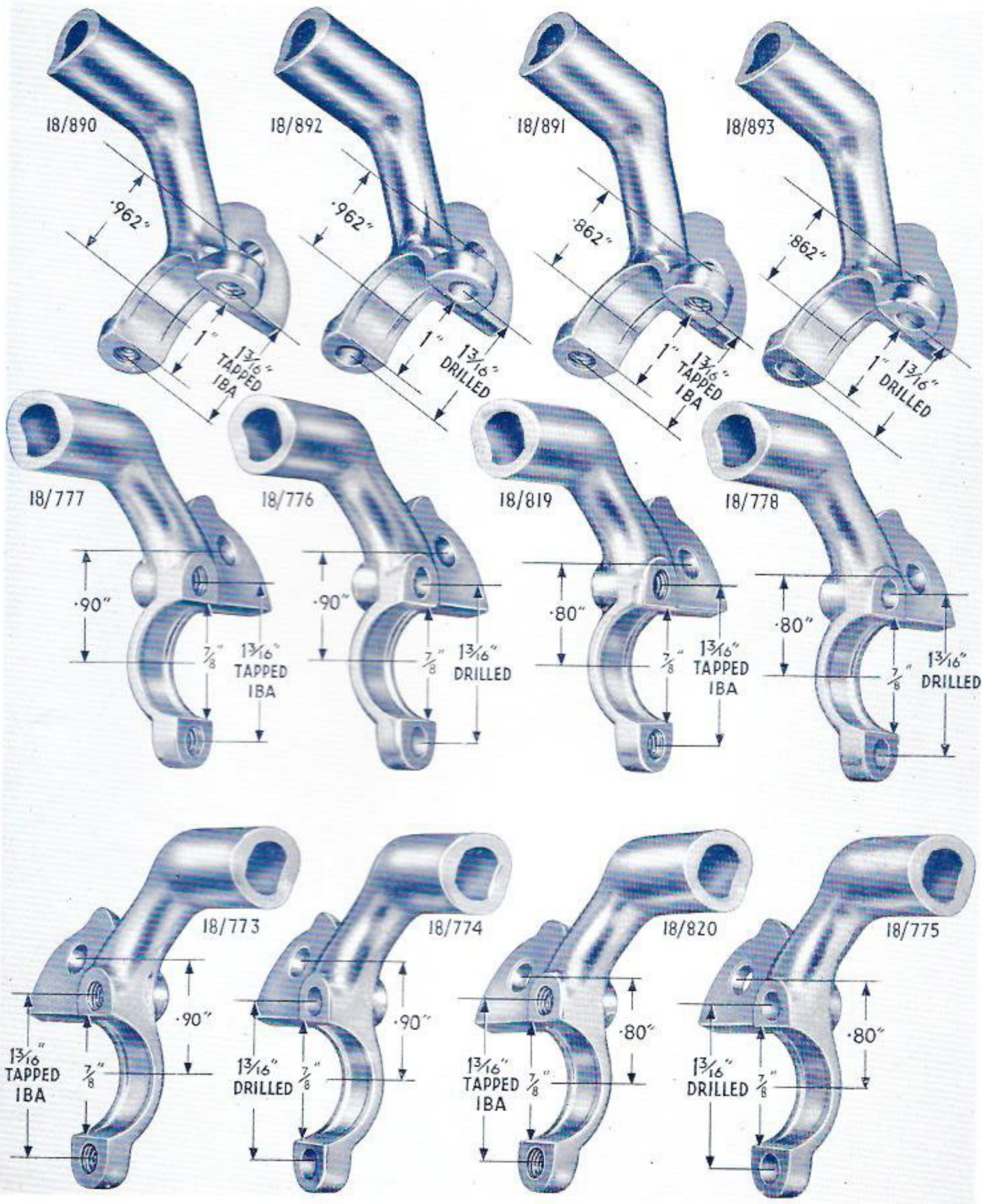

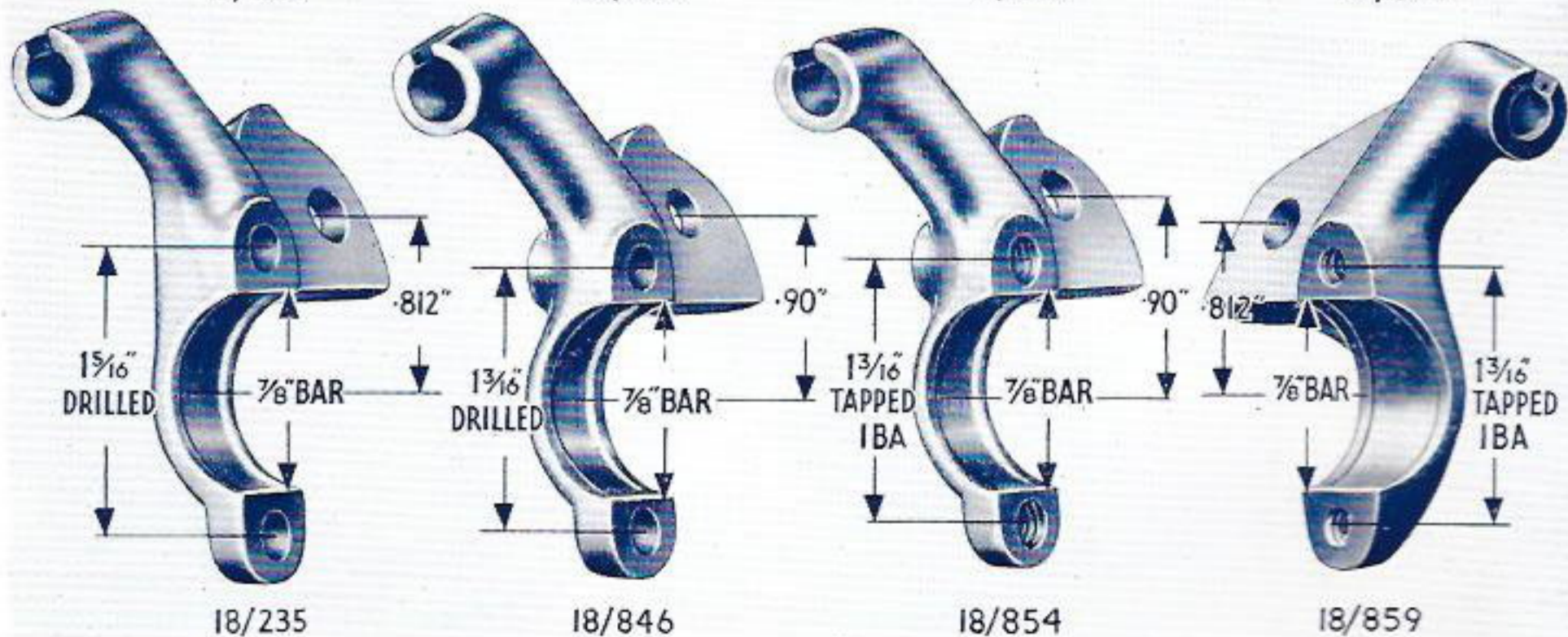
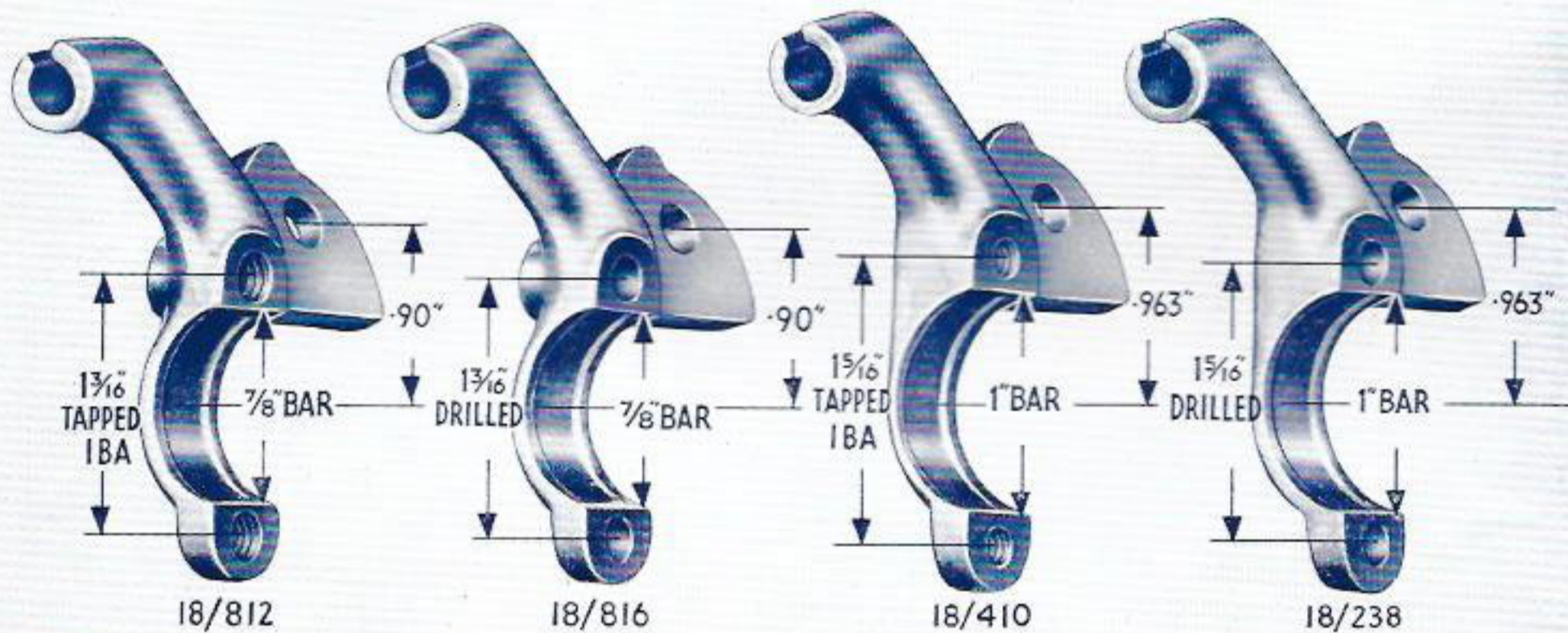
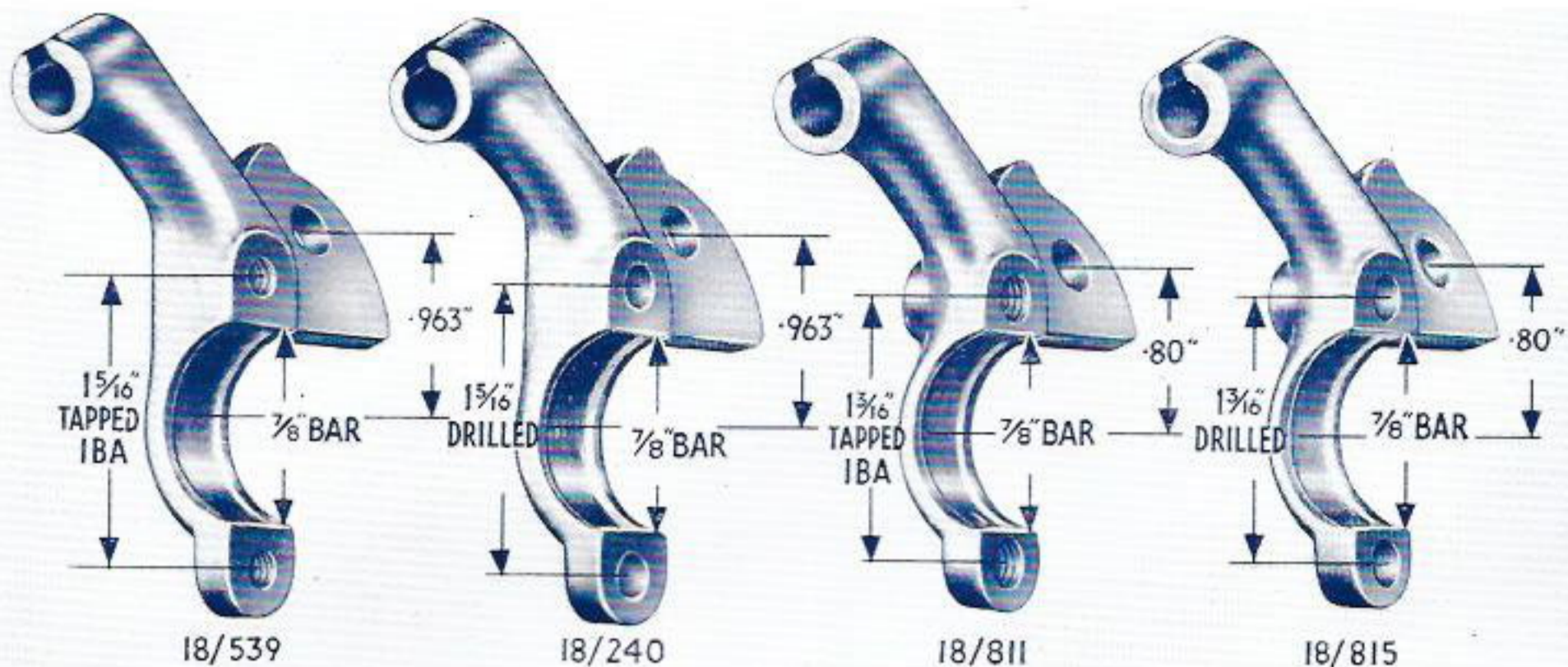

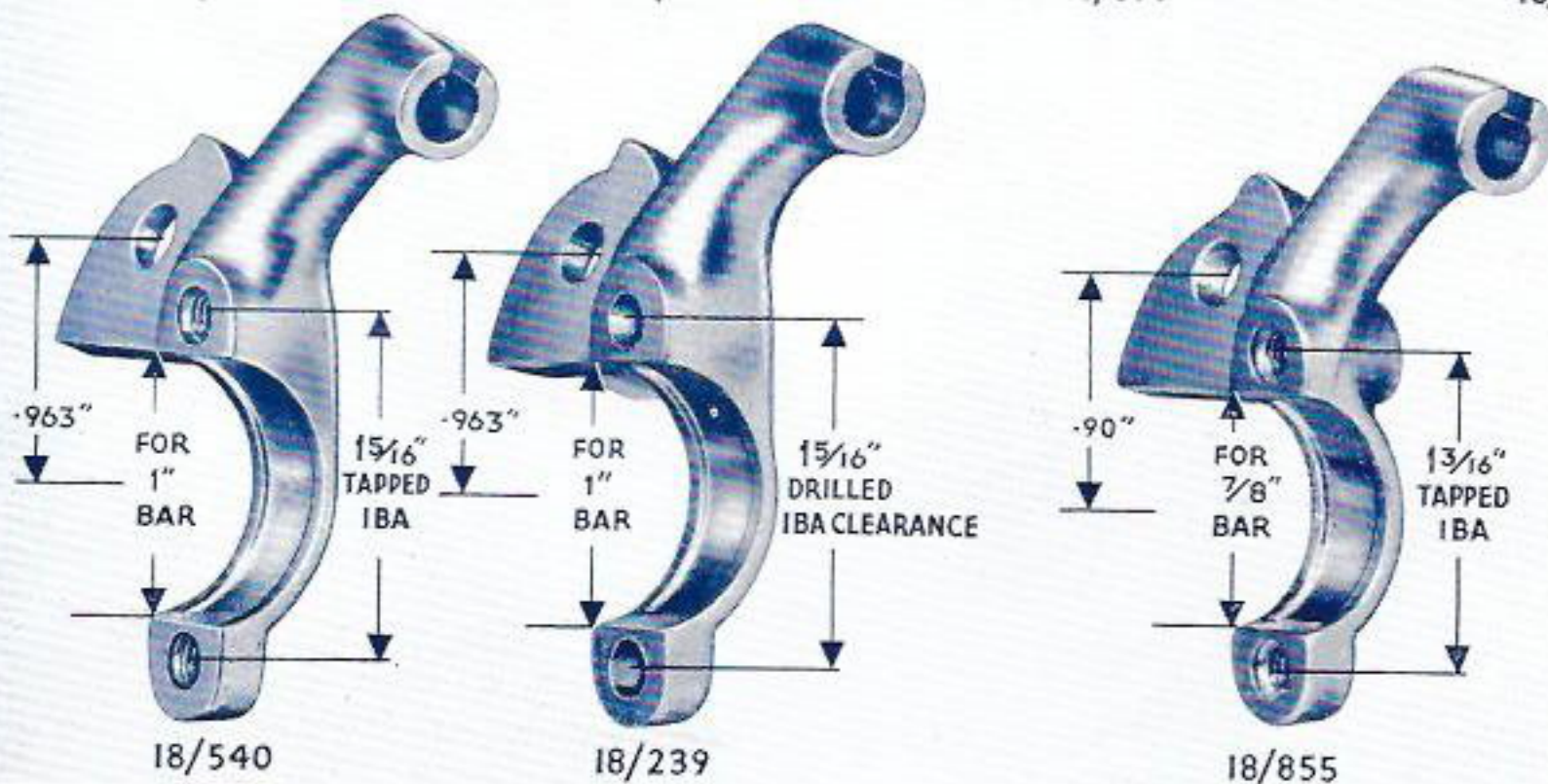
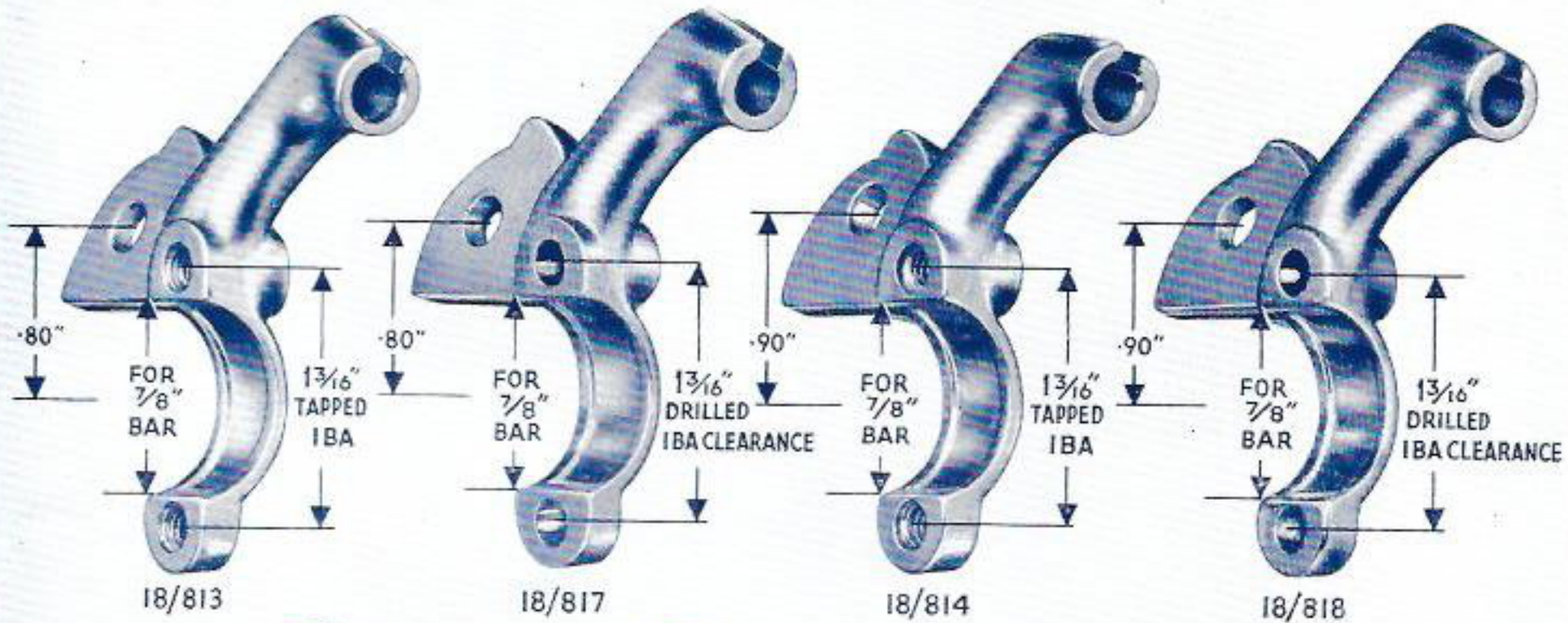
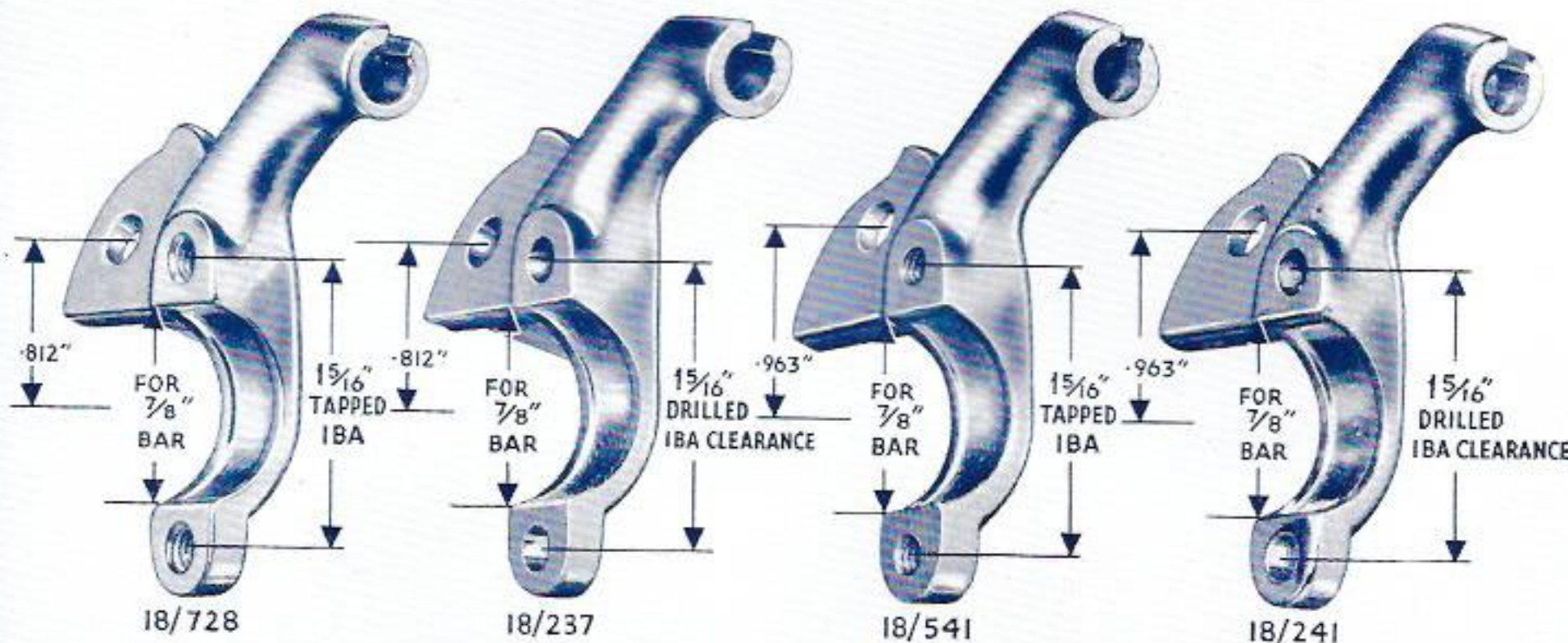

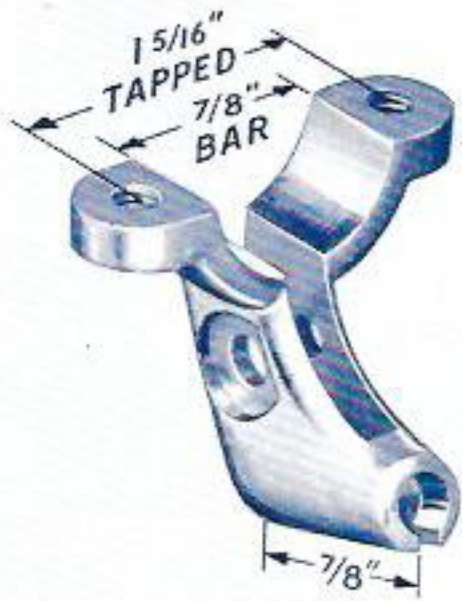

18/021



18/023

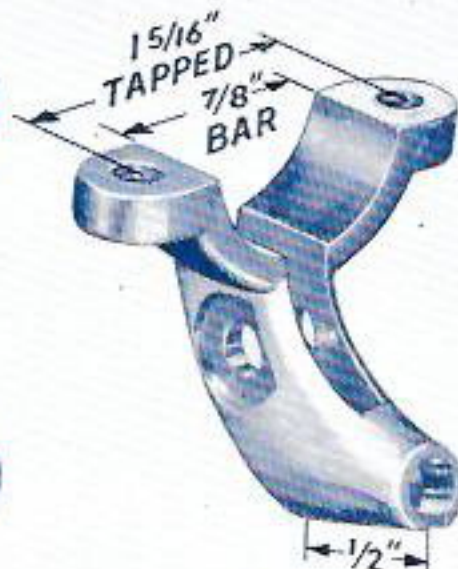

18/161



18/320



18/020

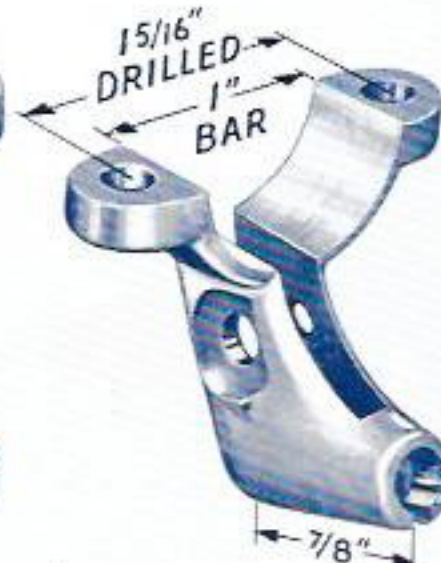

18/022

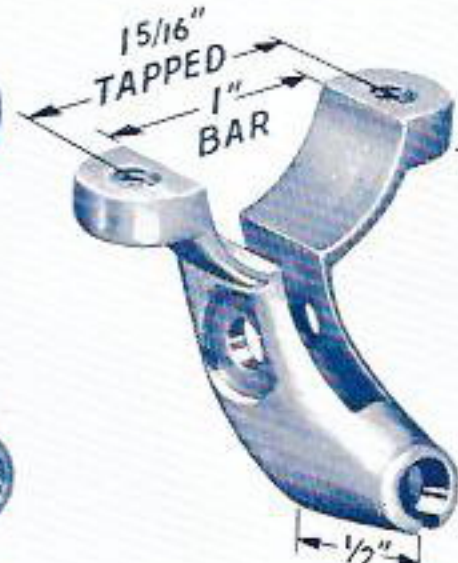

18/221



18/636

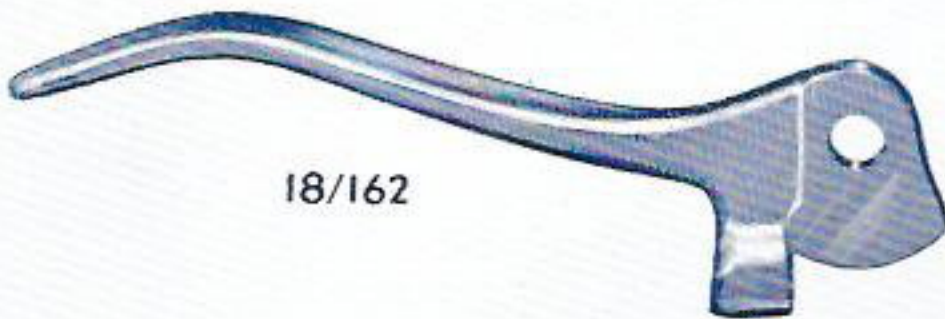

18/162



18/059

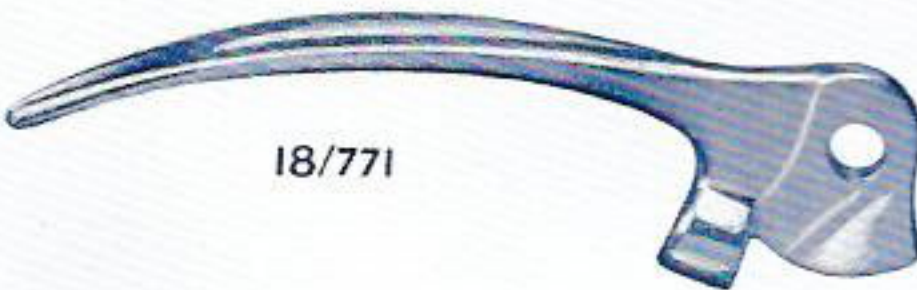

18/771



12/044



12/040



18/060

11/014

CLAMP SCREW & FULCRUM PIN



12/012



12/434



12/014



12/408



12/016



12/566



12/523



12/553



12/556



12/550



12/057

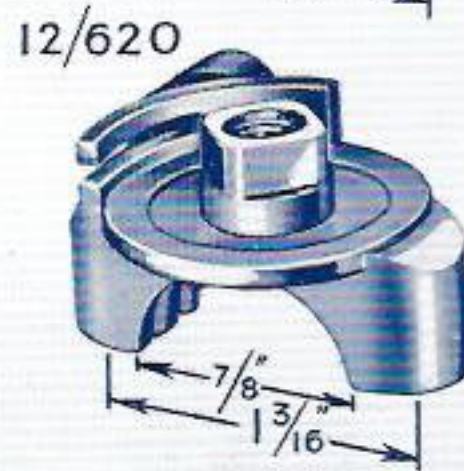
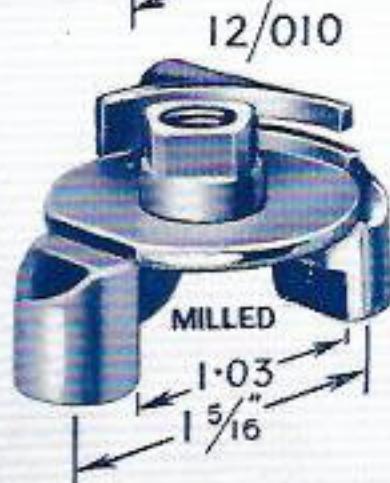
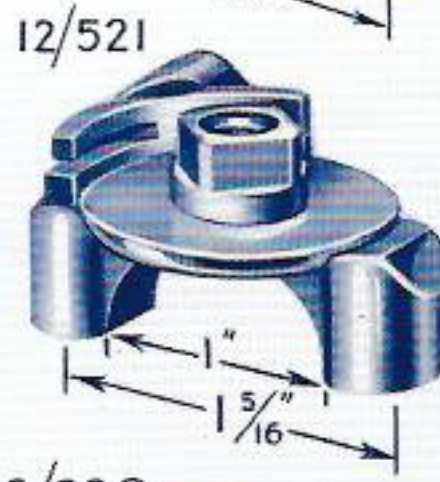
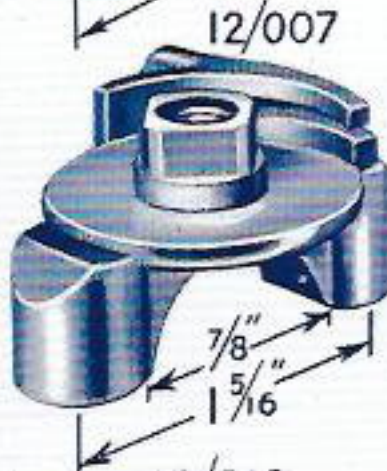
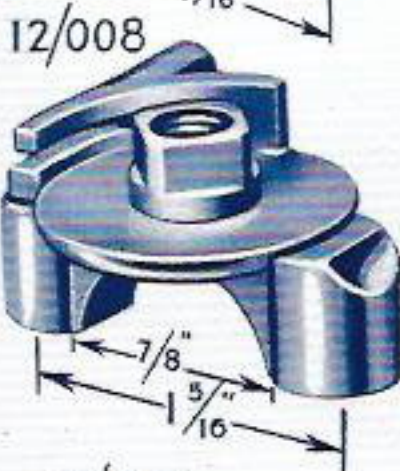
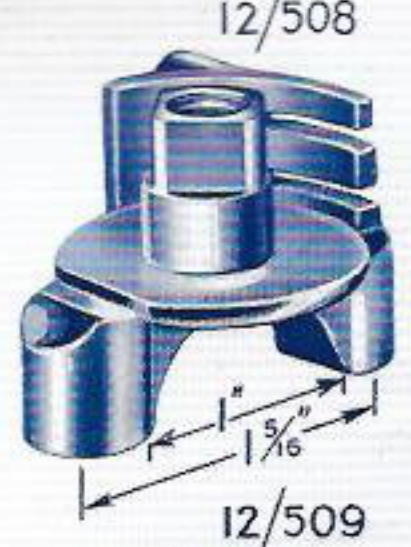
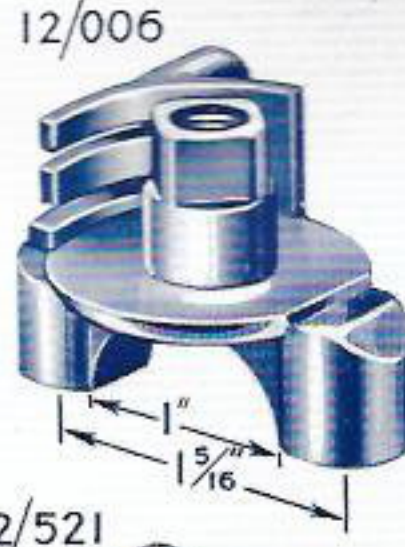
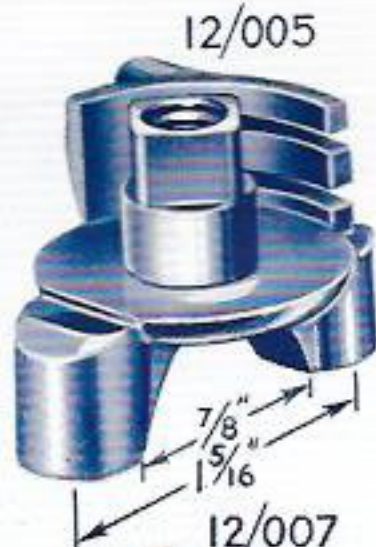
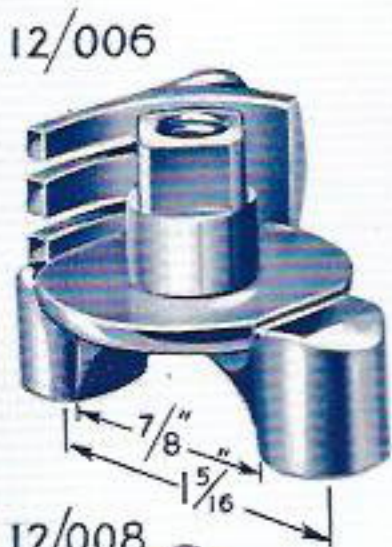
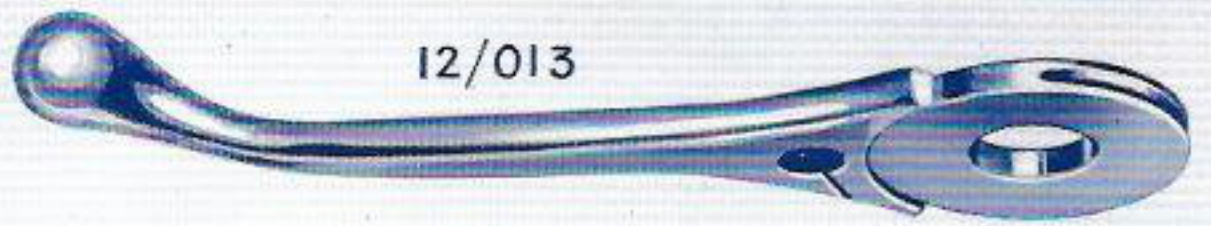



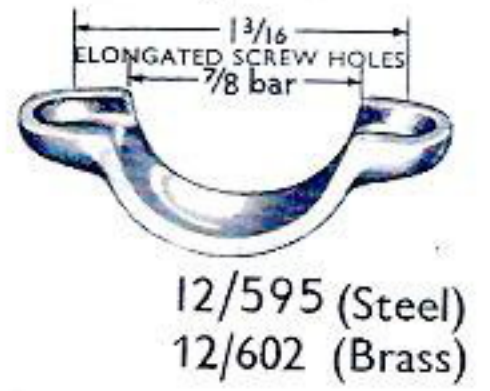
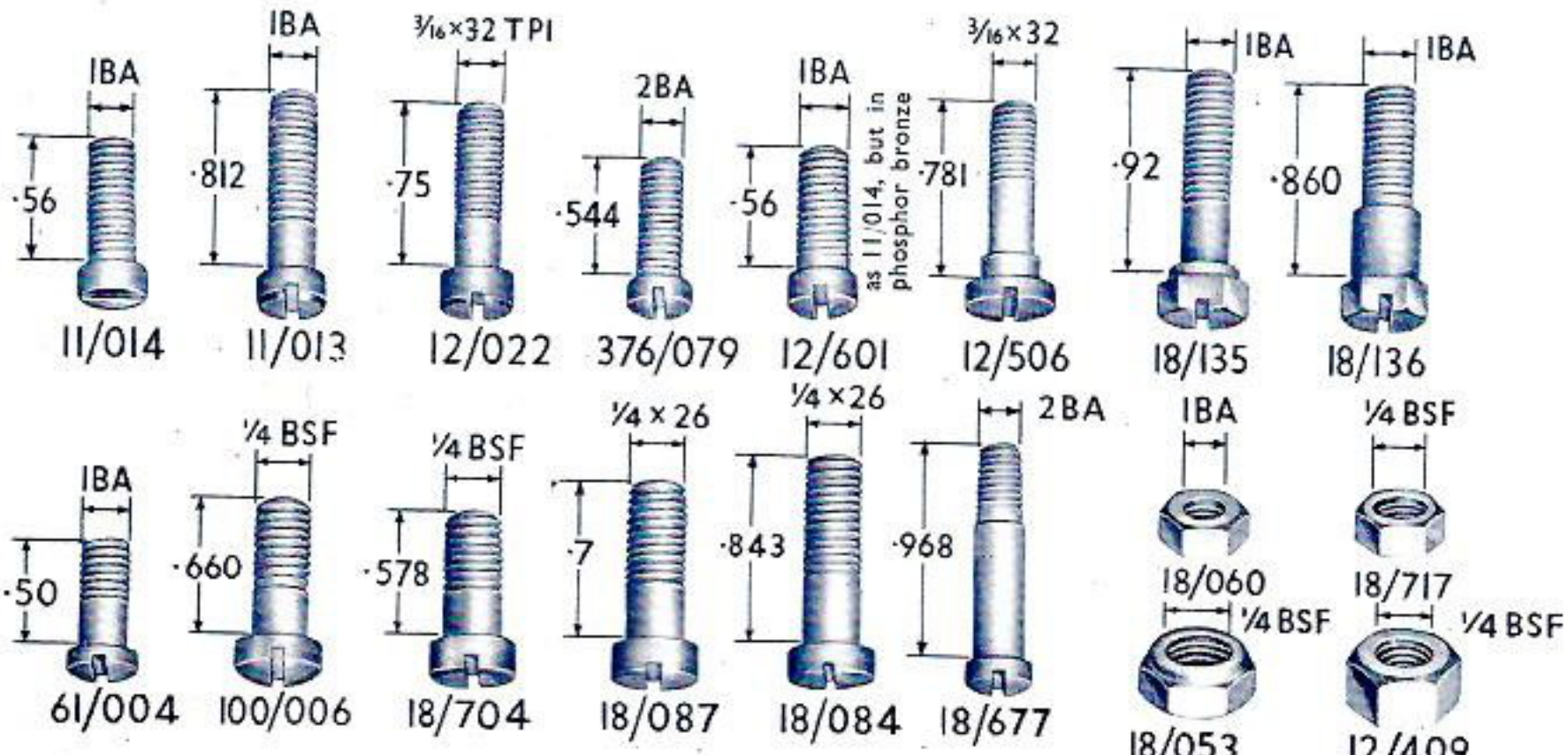

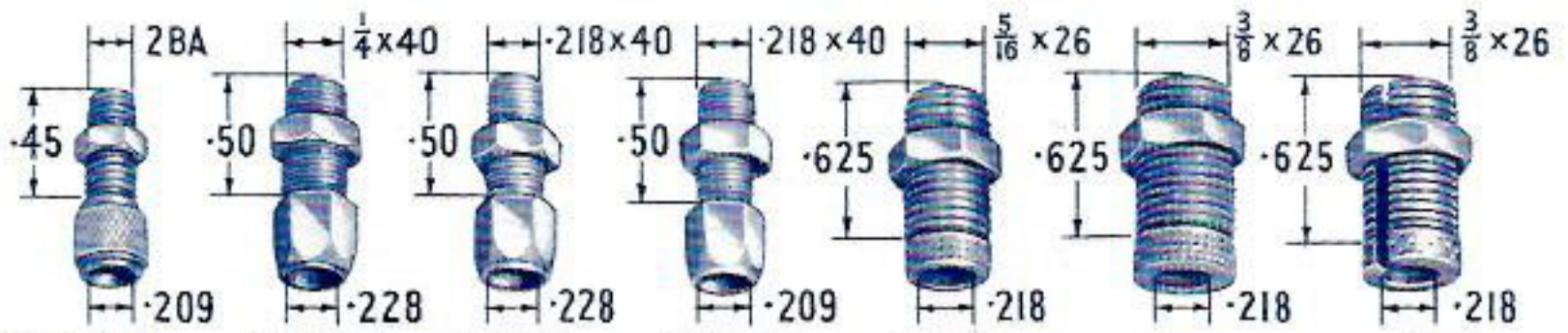

ADJUSTER 308/041 175/314 4/035 52/068 2626 3360 316/159
 NUT 308/042 175/315 5/077 52/077 2627 3369 3369

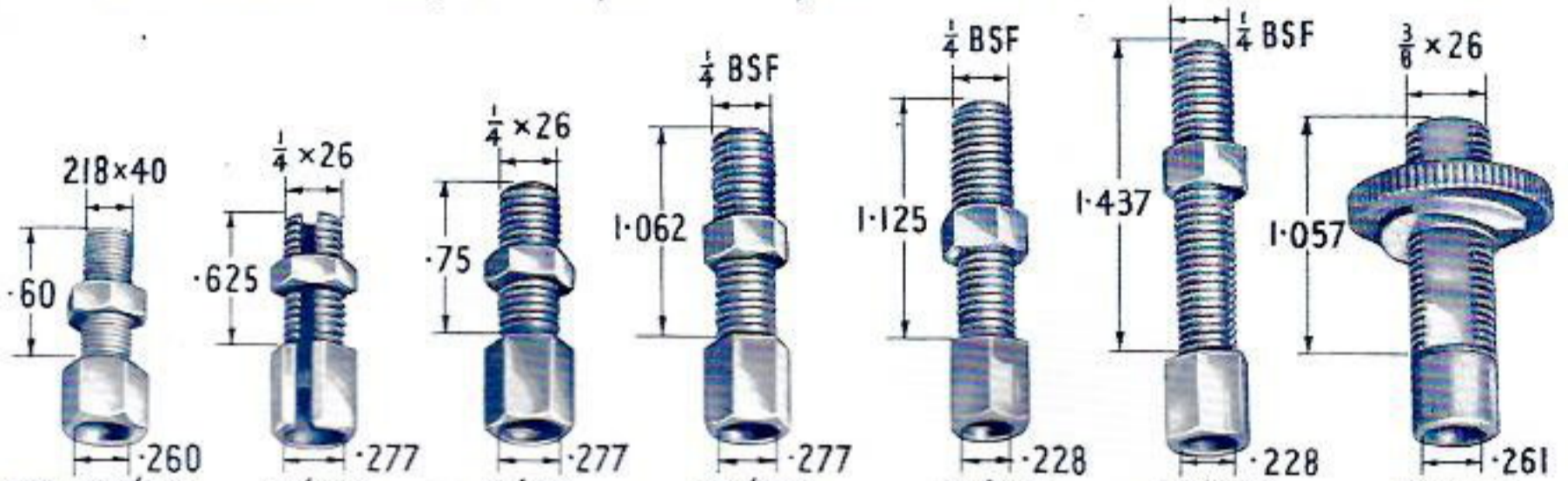

ADJUSTER 361/084 18/122 18/109 40/030 18/664 18/078 18/838
 NUT 5/077 3792 3792 40/031 40/031 40/031 18/839

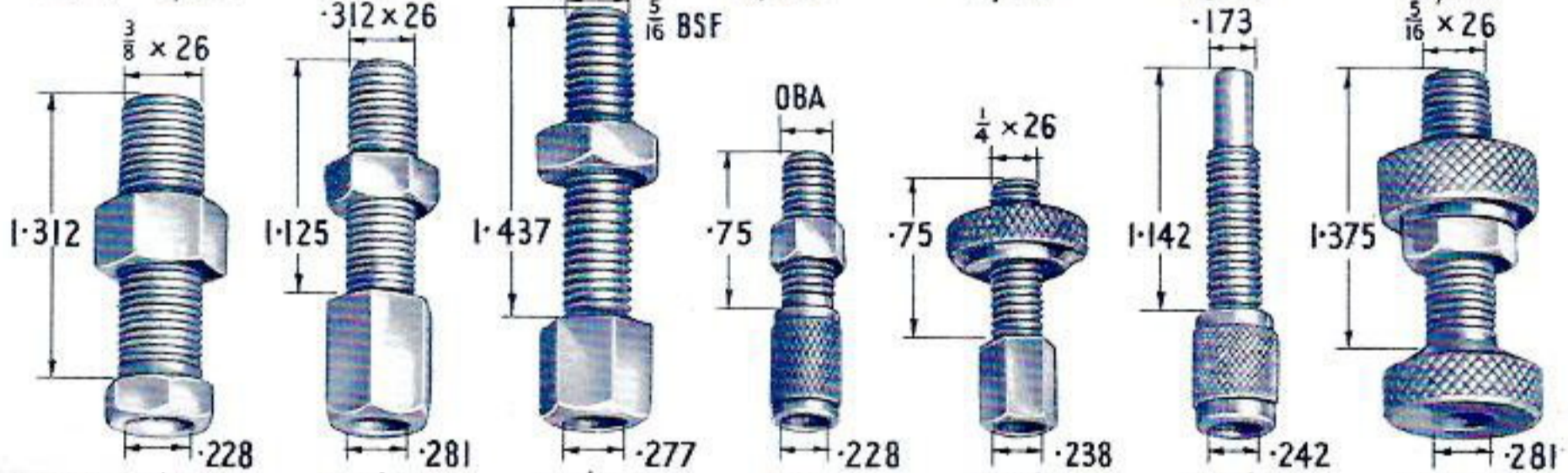

ADJUSTER 18/792 40/116 18/744 8145 244/934 244/391 18/736
 NUT 18/791 40/066 18/745 8146 244/935 244/391 18/737



18/676



18/679



18/690



18/880



18/606

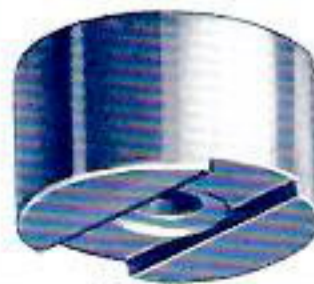

12/052

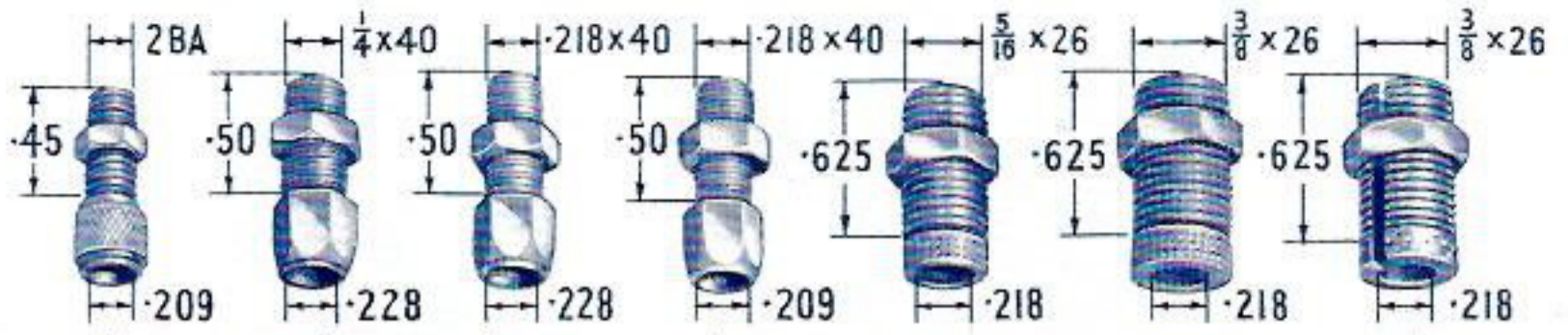

ADJUSTER 308/041 175/314 4/035 52/068 2626 3360 316/159
 NUT 308/042 175/315 5/077 52/077 2627 3369 3369

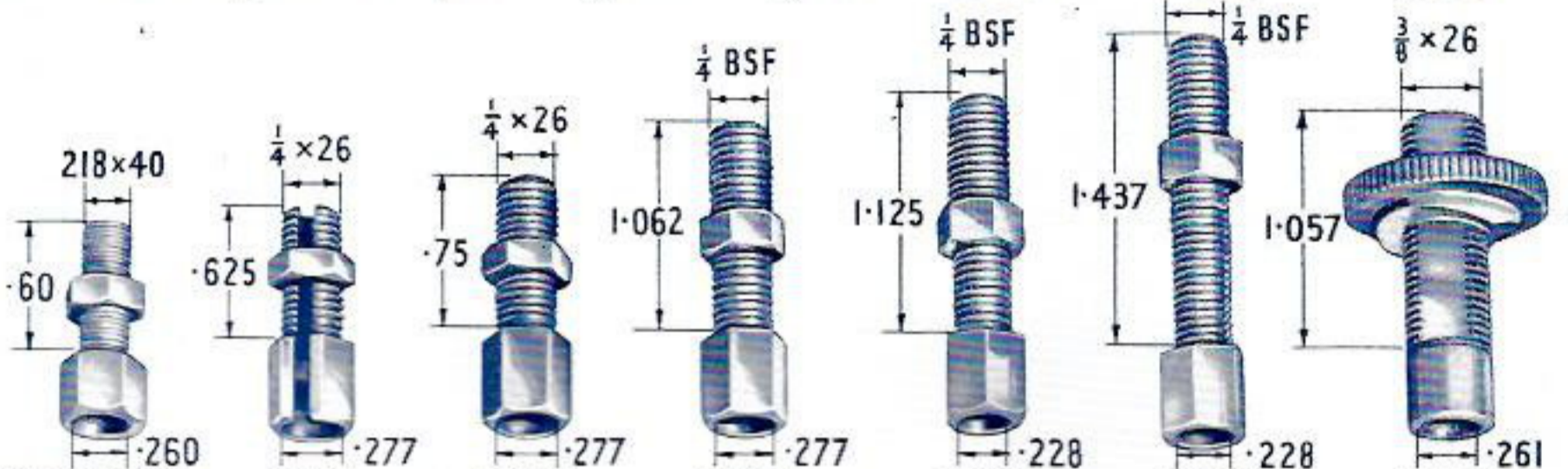

ADJUSTER 361/084 18/122 18/109 40/030 18/664 18/078 18/838
 NUT 5/077 3792 3792 40/031 40/031 40/031 18/839

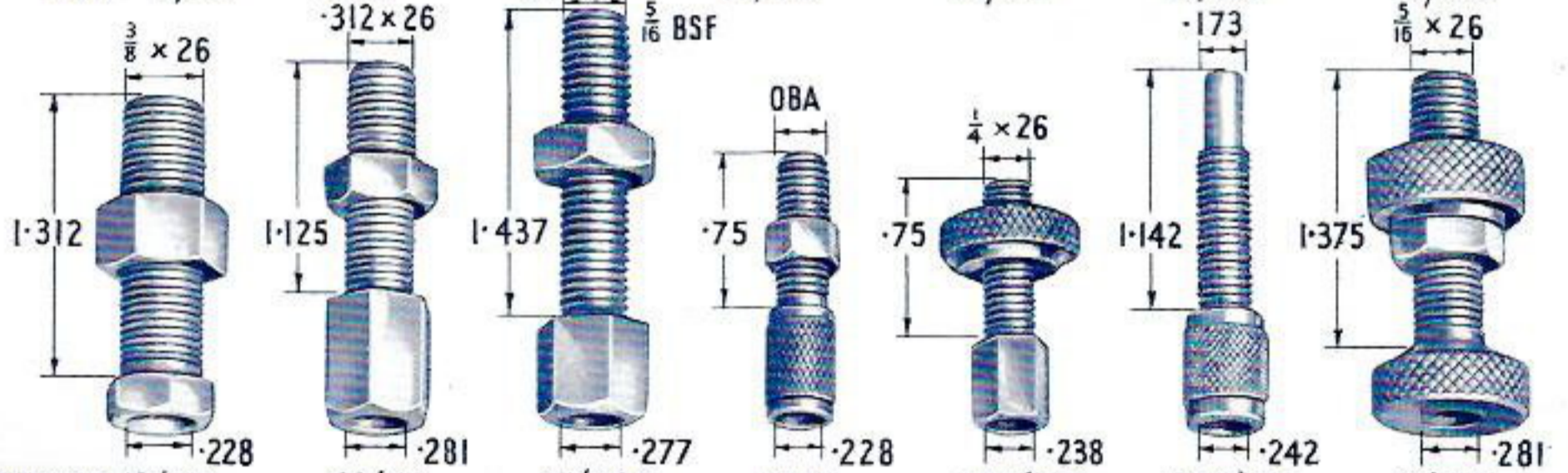

ADJUSTER 18/792 40/116 18/744 B145 244/934 244/391 18/736
 NUT 18/791 40/066 18/745 B146 244/935 244/391 18/737



18/676



18/679



18/690



18/880



18/606



12/052

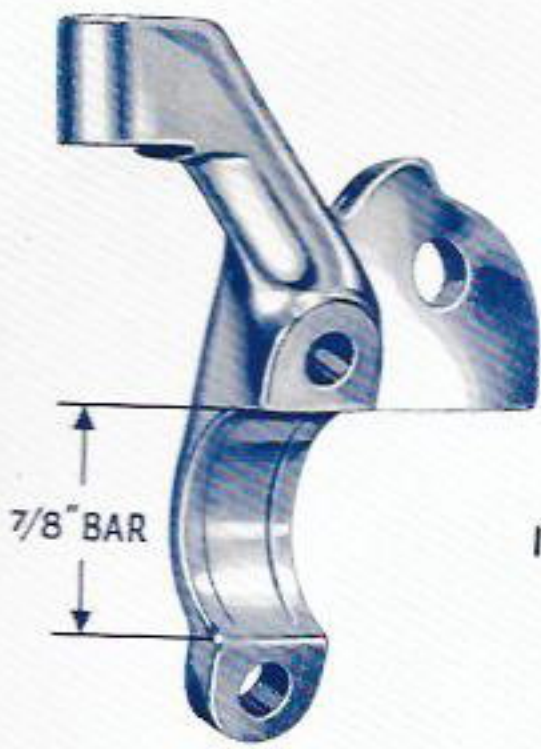

7/8" BAR

18/687

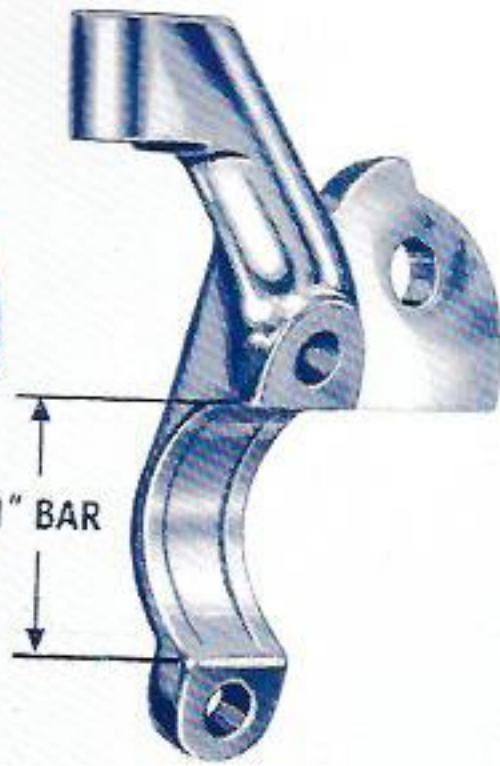

1" BAR

18/688



12/003



4/085



12/001



12/061



12/588



12/419



12/060



12/020



12/050



12/075



12/424



18/680



20/003



20/020



20/010



20/001



20/021



12/021



372/004



372/007

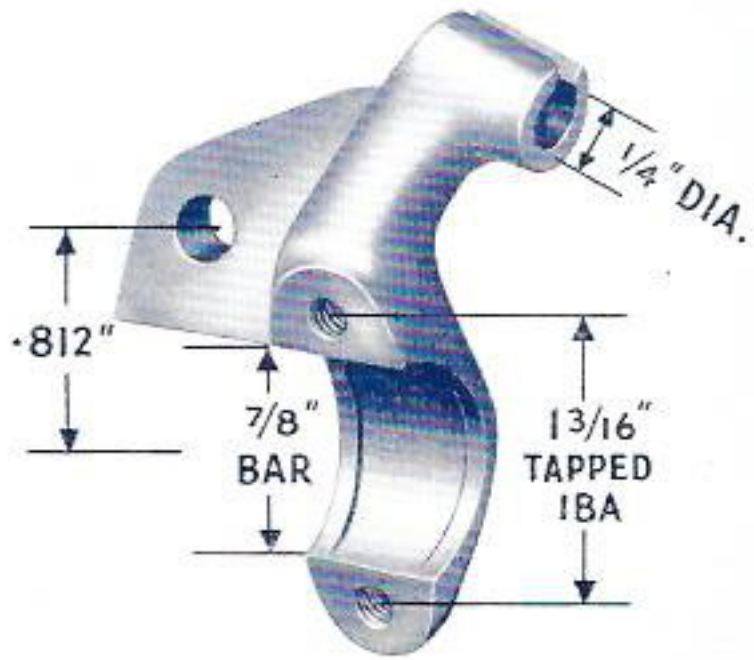

18/903



372/014



372/001

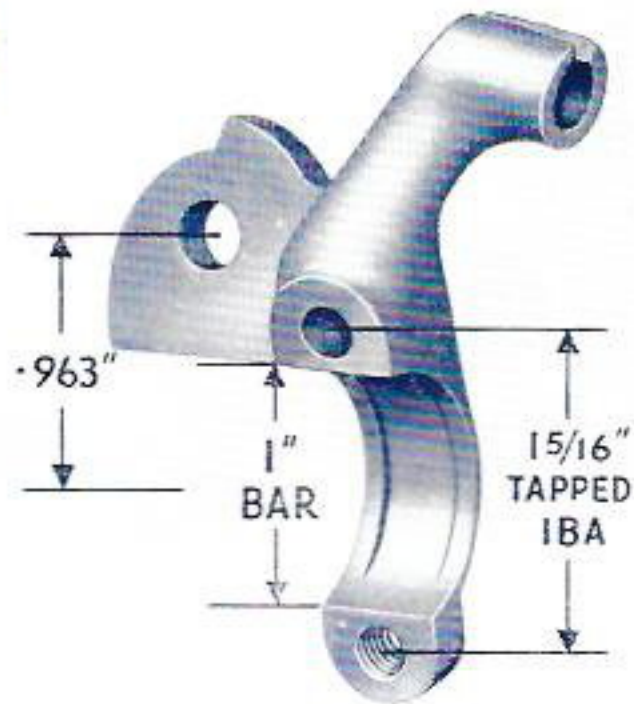

18/882



372/003
(3/4" BAR)



372/002
(7/8" BAR)



372/005



372/006



12/021



244/1348

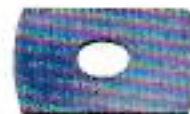

244/1349

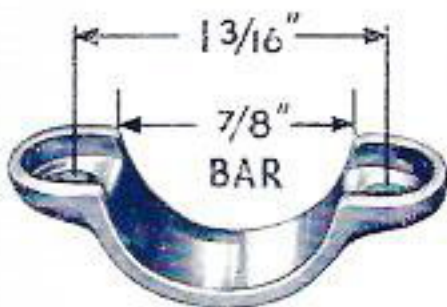

12/604



18/883