

Practical Aspects of Carburetion

A Discussion of some
of the Modern Carburetors
in General Use Today

Illustrations courtesy "The Motorcycle"

by Hank Elfrink

Technical Editor

NO ONE can deny that the modern carburetor is a complicated instrument with numerous correction devices to insure a good mixture for the considerable speed range of the modern high-performance engine.

Carburetor constructions in the pioneering days of motoring were primitive and crude, the earliest designs being so-called surface carburetors. Here the surface vapor of a large float bowl was drawn into the intake manifold by a draft passing over the gasoline surface. Later designs consisted simply of a float chamber and a single jet of fixed size. Those primitive carburetors could deliver a satisfactory mixture only at a predetermined rpm. and, strictly speaking, were suitable only for stationary engines. The reason behind this lies in the fact that the two components of a combustible mixture (gasoline and air) do not obey the same law with regard to rate of flow. The primitive single jet carburetor without correction devices would tend to deliver too rich a mixture at high rpm.

The reason these crude instruments still functioned fairly satisfactory lies in the fact that in the early days motorcycle and automobile engines operated through a narrow speed range, and change of speed was obtained by lifting the exhaust valve, slipping the clutch or drive belt rather than by operating a throttle valve.

Correction methods to make carburetors adaptable to a wide speed range are achieved mainly by the following methods: 1. extra air, 2. compensating jet, 3. variable jet and variable choke combined, and sometimes a combination of these methods. Apart from these differences, all carburetors consist essentially of two main parts: the float chamber and the mixing chamber.

Although there are constructional

differences, float chambers are virtually alike, consisting of a float and needle device to keep the fuel at a constant level.

The average combustible mixture consists of an approximate 15 to 1 air-gasoline weight ratio, in other words, 15 lb of air are required to completely burn 1 lb of gasoline.

The required air-fuel ratio is not the same along the speed range and it also depends on engine loading. In fact, the mixture ratio may vary between 12 to 1, a rich mixture for peak loads, to a weak mixture of approximately 16 to 1 for the lower speeds.

Amal Carburetor

The most widely used carburetor for British motorcycles is of course the famous Amal. This carburetor is a very efficient instrument manufactured to close tolerances and the correction methods are very ingenious.

The Amal carburetor could loosely be defined as a needle-jet type. Its mixture correction methods are by a variable jet orifice and variable venturi (choke) combined, but it also employs air bleed to a so-called primary choke. Another important feature of the Amal carburetor is the cut-away throttle slide. This throttle slide can be moved up and down and its position in the carburetor bore determines the size of the choke. Attached to the throttle-slide is the tapered needle to be seen in the illustration. Throttle-slide and taper needle operate in unison to maintain the correct mixture ratio according to engine speed and load.

There are two fuel jets, the pilot jet for idling and slow running, and the main jet for the high-power requirements. Both these jets are fed from the chamber to be seen at the base of the mixing chamber. The pilot jet terminates at the engine side of the throt-

tle-slide. Situated above the main jet surrounding the taper needle is the so-called needle-jet and, concentric with the latter, the primary air-choke.

Correct mixture strength is achieved as follows: For idling speeds and up to approximately one-eighth throttle opening, mixture ratio is governed by adjustment of the pilot air screw; from one-eighth to one-quarter throttle opening by the amount of cut-away on the throttle slide; from one-quarter to three-quarters opening by the position of the throttle needle; from three-quarters to full bore, by the size of the main jet. It must be realized that the duty of the taper needle and the needle jet is to govern the fuel flow through the main jet. Except for high loading and high speed conditions near the top end, the full flow capacity of the main jet is not used.

The pilot or idling jet has an air bleed adjustment screw; turning this screw in a clockwise direction enriches the idling mixture and vice versa. Very important is the cut-away at the leading edge of the throttle slide, and Amal throttle slides are available with different cut-aways to suit different machines. Lists are available with recommended throttle slides, jet sizes and needle positions. Every throttle slide is marked to indicate the extent of the cut-away. A larger cut-away weakens the mixture and vice versa, in the range from fast idling speeds until the speed range where the needle-jet takes over.

Mixture strength in the medium ranges can also be varied by altering the position of the needle in the throttle slide. A richer mixture is obtained when the needle is raised by placing the retaining clip in a lower groove. Conversely, the weakest mixture results by placing the clip in the end (no. 1) groove.

Some types of Amal carburetors are

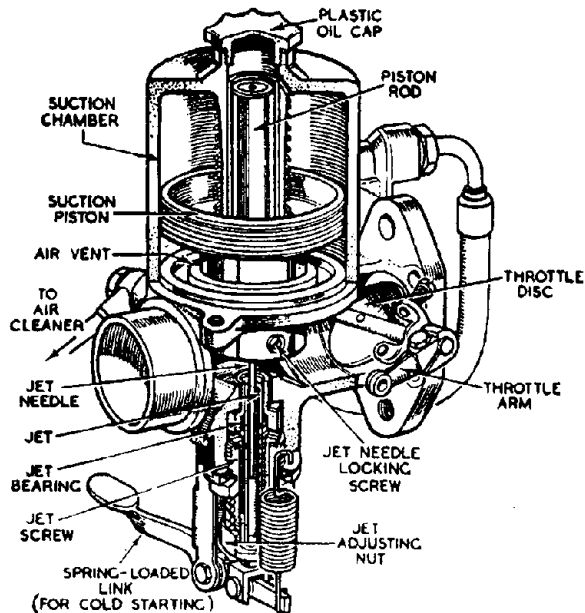

The constant vacuum type 5.U. carburetor. This design features only one fuel jet. Fuel flow through this jet is governed by the vacuum operated taper needle.

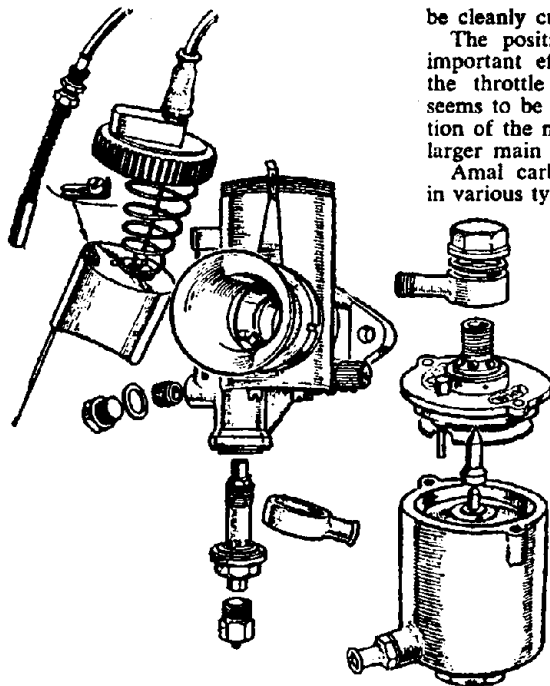

be cleanly cut and the plug examined. The position of the needle has an important effect in the upper end of the throttle range, so if the engine seems to be starving, try a higher position of the needle before deciding on a larger main jet. Amal carburetors are manufactured in various types. Although the principle

The Amal Grand Prix carburetor features an unobstructed choke on full throttle because of the metering needle not passing through the carburetor bore. Needle is fitted at the side of the throttle slide. The only restriction is the slight protrusion of the spray tube. For special purpose-tuning a different size air bleed jet (primary air) may be fitted.

larger jet has to be fitted (approximately 2.5 times as large, an increase of 150% on the basic jet size for 80 octane gasoline.) If a 300 jet is used for 80 octane gas, a 750 jet and the appropriate needle jet would be needed if the same motor were to run on methanol. This is the minimum requirement; there is a lot of latitude in running on alcohol and a large jet may be fitted in the interests of engine cooling to keep piston, valve and cylinderhead temperatures down.

Idling
If idling is erratic, the throttle cable adjustment should be checked to see if the throttle slide can be fully closed. Loosen the throttle stop until the engine begins to falter; then adjust the airscrew, which probably will make the engine run faster. Now again adjust the throttle slide stop and it may be possible to make a still finer adjustment on the air screw. If necessary go through this procedure a third time. When the right setting is arrived at, tighten the throttle screw lock nut securely, holding the screw firmly. Readjust the throttle cable to eliminate all slack. The throttle slide should move the instant the twist-grip is turned.

If, on road testing the machine, the carburetor spits back, indicating a weak mixture (assuming the ignition is not retarded), it may be necessary to enrichen the idling mixture by screwing the air screw in half a turn. If this does not help, a slide with a smaller cut-away may be in order.

Dirt in the carburetor can also upset the mixture greatly. Dirt on the float chamber needle or seat often is the cause of flooding. A blocked main jet causes insufficient pulling power at high loads. A blocked pilot jet makes the engine very difficult to start.

Talking about starting: a machine equipped with an Amal carburetor should be started on the pilot jet, in other words with the throttle on or near idling speeds. The nearly closed throttle slide causes a great air velocity and consequently a low depression near the pilot jet orifice.

The Amal Monobloc Carburetor

A new type Amal carburetor, the "Monobloc," has recently been introduced. As can be seen from the illustration, the float chamber is integral with the mixing chamber and a hinged float is used with a short nylon float needle. It has been found that this type of needle does not wear the seat and that it gives better sealing. Another good feature is the easily demountable jet holder which gives easy access to the main- and the needle-jet. The principle of operation is very similar to the conventional Amal design.

An advantage of the new construction is that the carburetor can be mounted at an angle, and, also, tilting of the machine on turns does not affect the consistency of the mixture. Cleaning of the float chamber is easy and it is not necessary to disassemble the carburetor.

fitted with an air valve (choke valve). This valve should only be used to start the engine from cold. A tickler to flood the carburetor is also provided.

Tuning the Amal carburetor is straightforward, assuming the machine to be in good condition and that the carburetor fitted is the correct type. All adjustments should be made with a thoroughly warmed up and normalized engine.

The Amal company recommends to start tuning procedures with a check on the main jet size. The smallest jet which gives the greatest maximum speed should be selected (with a small safety factor for cooling; cylinderhead temperature also has a pronounced influence on performance). The jet size marked on the side of the jet represents the flow in cc. per minute on a special Amal calibrating machine. Jets are made in 10 cc. increments. The spark plug is the guiding factor in evaluating mixture tests. After a full power test run for a few miles, the throttle should

of operation of nearly all Amal carburetors is alike, there are important detail differences. On the T.T. carburetor, for instance, the pilot jet adjustment regulates the fuel flow and not the air. The top feed of the float chamber is also slightly different. It is equipped with a handlebar operated air control at the side of the carburetor which affects the richness of the atomised mixture as it passes through the primary choke.

On the G.P. carburetor the metering needle is fitted at the side of the throttle-slide and does not pass through the choke of the carburetor, and except for the small protrusion of the spray tube there is no restriction in the carburetor throat when the throttle slide is fully open.

The Amal company also manufactures non-needle type carburetors which have two jets of a fixed size (a main jet and pilot jet) for small two-stroke and four-stroke engines.

For straight methanol running, a

New Subscription Order Form

CYCLE MAGAZINE

1268 So. Alvarado St., Los Angeles 6, Calif.

Enter my personal subscription to start with the next issue:

\$3.50 enclosed for one year Send Invoice

NAME.....

HOME ADDRESS.....

CITY..... ZONE..... STATE.....

COMPANY.....

POSITION.....

(Above rates good only in United States and Canada)

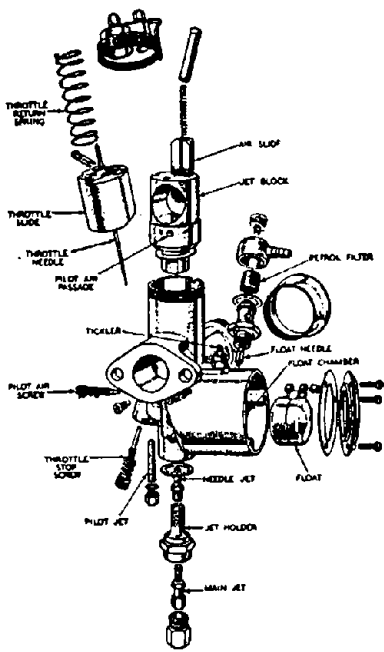

The new Monobloc carburetor features a float bowl and mixing chamber cast as one unit. A hinged float and nylon float needle are used.

around the needle jet is a well which contains gasoline when the throttle opening is small. This extra fuel momentarily enriches the mixture for snap acceleration when the throttle is opened wide; in fact it has an effect similar to

that of the accelerating pump on automobile carburetors.

The pilot jet is demountable for cleaning purposes and, when assembled in the carburetor body, is sealed by a cover nut.

The S.U. Carburetor

A very interesting carburetor is the S.U. carburetor. The S.U. is a widely known make and it practically dominates the British sports-and-racing car field.

After a long absence, the company is re-entering the motorcycle field (early Douglas machines were fitted with S.U. carburetors). The new 1955 Ariel Square Four is fitted with an S.U. carburetor.

The S.U. resembles the Amal design in that it also employs the needle jet principle and correction methods also are by variable jet orifice and variable choke. There are, however, very essential differences.

In the first place, the S.U. has only one fuel jet which takes care of the correct mixture from idling speeds to full bore, and there is no air bleed to a primary venturi.

Secondly, the movement of the taper needle in the S.U. instrument is not directly controlled by the throttle. It also has a separate butterfly throttle.

The essential part of this carburetor is the piston and suction disc body carrying the taper needle, which terminates in the single fuel jet. The piston movement to vary the choke diameter has

a function similar to that of the Amal throttle slide, but in the case of the S.U. the piston is vacuum operated. The suction disc is subjected to atmospheric pressure on the underside and the depression in the region of the jet is conveyed to the top side. A vertical passage in the piston connects the top side of the disc to the jet area.

The position of the piston and vacuum disc depends on three factors: throttle opening, engine speed and engine load.

At wide throttle openings when the depression in the jet area—and consequently on top of the disc—tends to be considerable, the suction disc will lift, withdrawing the needle from the jet, thus increasing the flow of fuel. Lifting of the piston has at the same time increased the choke diameter; the taper of the needle and varying choke diameter combining in such a way that a correct mixture is delivered through the speed range.

At idling speeds, the piston drops to a very low position and although the taper needle has sunk into the jet, almost closing the orifice, the small choke insures a high velocity of air near the jet; and this is the reason why a separate idling jet is not necessary. This piston action results in an approximate uniform degree of depression in the region of the fuel jet, and that is why the S.U. is called a constant vacuum carburetor.

An interesting feature is that the jet-

(Continued on page 38)

YOU can DO BEST on a MATCHLESS

AVERAGE RIDERS BECOME EXPERTS when they change to MATCHLESS

THEY GO BEST — HANDLE BEST — RIDE BEST

FRANK H. COOPER

COOPER MOTORS

WESTERN U.S.A. DISTRIBUTOR

EASTERN U.S.A. TEMPORARY DISTRIBUTOR

5832 So. Broadway, Los Angeles 3, Calif.

ADams 1-9115

960

If Harley-Davidson makes it,

WAGER & WALKER



WAGER & WALKER

FOR FRIENDLY HAR.-DAV. SERVICE
419 East 4th St., Santa Ana, Calif.

HARRY'S MOTORS

BSA — INDIAN

Parts, acc., new, used machines. Freight prepaid on all parts and machines anywhere in the world.

★ Phone ★ Wire ★ Write

J. P. TAGARIS & SON

965 Santa Fe Dr., Denver 4, Colo.
Alpine 9-9274

1 Day Mail Order Service

on Indian parts and accessories. Armature and generator exchange, motors reconditioned, cylinders rebored. Send for lists from the largest and most complete stock of Indian parts in the Middle West.

INDIAN MOTORCYCLE SALES CO.
2701 Truman Road Kansas City, Missouri

Al Lower Cycle Shop



- Sales
- Service
- Parts
- Speed Tuning

917 20th Street, Sacramento, Calif.

ATTENTION!

The most complete stock of Matchless, AJS and Lucas parts in the Midwest. Amal carburetor parts for most English models.

SHORES MOTORCYCLES

Joseph Schothofer, prop.

1983 E. Eight-Mile Rd., Hazel Park, Mich.
Stacum 7-9880

ATTENTION CATALINA RIDERS

PETE'S PRETTY PLATES

Check our advertisement on Page 44

MOTORCYCLE INSURANCE

All forms of insurance for Motorcycle Owners, Riders and Clubs

- Bodily Injury and Property Damage Liability
- Fire, Theft & Collision

No coverage in Canada or Bodily Injury & Property Damage Liability in Massachusetts or New York. No age restrictions. Excellent Claim and Underwriting service. Write for applications.

MOTORCYCLE UNDERWRITERS

111 W. Monroe St. • Suite 1308
Chicago 3, Illinois

CARBURETION

(Continued from page 35)

body can be lowered in relation to the needle—and also in relation to the fuel level in the floatbowl—so uncovering a larger part of the jet orifice.

The illustration shows the spring-loaded jet-lever used for lowering the jet-body for cold starting. There is no choke in the ordinary sense of the word. During the warming up period the jet-body is gradually raised to its

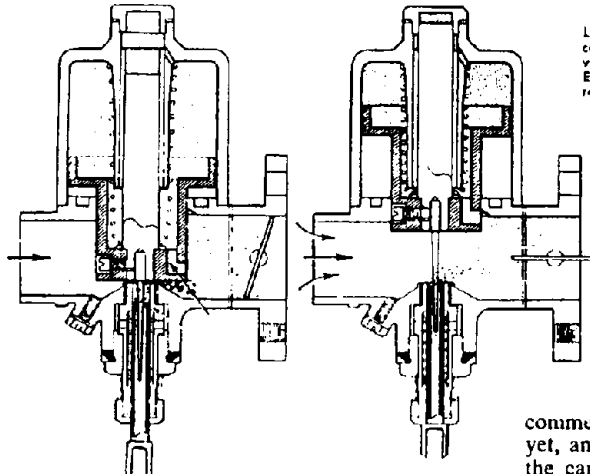

Left: Variable choke in S.U. carburetor maintains constant vacuum near jet area. Below: Exploded view of S.U. carburetor.

craft engines in the last war) and engines with direct injection can be had today, it is doubtful whether fuel injection for motorcycles would be a worthwhile

commercial proposition as yet, and it is safe to say that the carburetor will stay with

us for many years to come.—Hank Elfrink

abutment which should be the correct position for normal running. Tuning of the S.U. carburetor is simple. All jets are of standard size (for a given carburetor), and the only adjustment is the fitting of the correct needle with the jet adjusting nut—which determines the location of the abutment—set correctly for idling. When the carburetor is adjusted for correct idling, it will give a good mixture for the whole speed range. A larger needle will give a weaker and a smaller needle a richer mixture.

Mixture Adjustment

Tuning for mixture strength is achieved by raising or lowering the neutral position of the jet by turning the jet adjusting nut, which as we have seen forms the jet abutment. The illustration shows the compression spring which compresses the sealing glands to prevent fuel leakage.

A simple test for rich mixture is to lift the piston slightly; if the engine runs faster, the mixture is too rich. If the engine pulls better with the jet in a lower position, a smaller needle is required. A big advantage of the S.U. carburetor is that jet blockages are practically impossible on account of the big jet orifice.

All the moving parts in the S.U. carburetor are manufactured to extremely fine tolerances. The piston and suction-disc-body slides in the suction chamber with a very small clearance. The relative position of the needle in the piston body is extremely important, as the needle at its largest diameter is very nearly as large as the jet and yet must never touch it.

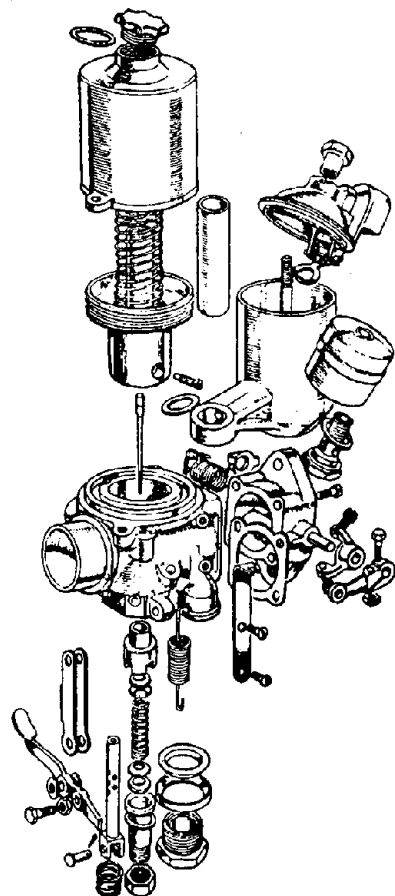

962