

LUCAS

♦ **MOTOR-** ♦
♦ **CYCLEALITIES** ♦

ELECTRICAL & NON-ELECTRICAL

1928



KING OF THE ROAD

LUCAS

MOTOR-CYCLE REALITIES

DESIGNED AND MANUFACTURED BY

JOSEPH LUCAS LIMITED

HEAD OFFICES AND WORKS:

GREAT KING STREET, BIRMINGHAM

TELEGRAMS & CABLES: "LUCAS, BIRMINGHAM." TELEPHONE: NORTHERN 2201 (10 LINES).
CODES USED: A B C (5TH AND 6TH EDITIONS) AND BENTLEYS

WHOLESALE DEPÔTS:

BELFAST—3-5, Calvin Street, Mountpottinger.

Telegrams: "SERVDEP, BELFAST."
Telephone: BELFAST 7017.

BRISTOL—25, Temple Street.

Telegrams: "KINGLY, BRISTOL."
Telephone: BRISTOL 8400 (3 lines).

CARDIFF (Opening shortly)—Penarth Road.

Telegrams:
Telephone:

DUBLIN—Taylor Bros., 41, Middle Abbey Street.

Telegrams: "AUTOLITE, DUBLIN."
Telephone: DUBLIN 653.

GLASGOW—227-229, St. George's Road.

Telegrams: "LUCAS, GLASGOW."
Telephone: DOUGLAS 3075 (3 lines).

LEEDS—64, Roseville Road.

Telegrams: "LUSERDEP, LEEDS."
Telephone: LEEDS 28591 (5 lines).

LONDON—224, Shaftesbury Avenue, W.C.2.

Telegrams: "GUIDEPOST, WESTCENT, LONDON."
Telephone: REGENT 8033 (3 lines).

MANCHESTER—291-293, Deansgate.

Telegrams: "LUMINOUS, MANCHESTER."
Telephone: CENTRAL 6420 (2 lines).

NEWCASTLE-ON-TYNE—64-66, St. Mary's Place.

Telegrams: "MOTOLITE, NEWCASTLE-ON-TYNE."
Telephone: CENTRAL 3571 (3 lines).

FOR LIST OF SERVICE DEPOTS SEE PAGE 60.

EXHIBITIONS.—The Goods listed herein are sold on the condition that they are not to be exhibited by any person, firm or company at any Exhibition in the United Kingdom of Great Britain and Ireland without our written authority.

WARRANTY.—We stand by all Goods of our manufacture. We spare no trouble or expense to ensure the quality of "LUCAS" Goods and are always ready to make good, by repair or replacement, any defect not caused by wear and tear, misuse, or negligence. This guarantee is in lieu of any guarantee implied by statute, and any damages for which we make ourselves responsible are limited to cost of repair or replacement by us or to our order.

LUCAS

"KING OF THE ROAD" PROJECTOR SET No. 472

No. 472 is a large Acetylene Projector Set giving a driving light which is extraordinarily powerful, the road being flooded with an even and penetrative light for a long distance ahead.

It is fitted with a **Mangin Lens Mirror**, is bold yet pleasing in appearance, and is built on similar lines to our Car Projectors. The finish is of the high class always associated with the name "Lucas."

The Generator is of the drip-feed type, has a two-way nipple, and the carbide container is fixed or unfixed by a slight turning movement. This fixing is a Lucas patent—therefore exclusive.

No.		CASH PRICE
472	COMPLETE SET —includes Projector No. 472, Generator No. 62, Double Bracket No. 61B for handle-bar, and Tubing. Ebony Black finish	£3 0 0

PROJECTOR ONLY—

No.	Height.	Weight.	Front.	Glass.	Burner.	Finish.	
472	7 $\frac{1}{4}$ in.	3 $\frac{3}{4}$ lb.	7 $\frac{1}{4}$ in.	6 $\frac{1}{4}$ in.	No. 52	Ebony Black	.. 2 0 0

GENERATOR ONLY—

62	Supplies gas for 4 $\frac{1}{2}$ hours. Ebony Black finish	15 0
----	--	------

Ebony Black is the standard finish, but Nickel Plated can be supplied if ordered.

POSTAGE EXTRA.

"KING OF THE ROAD"
SET NO. 472
(WITH DOUBLE BRACKET)

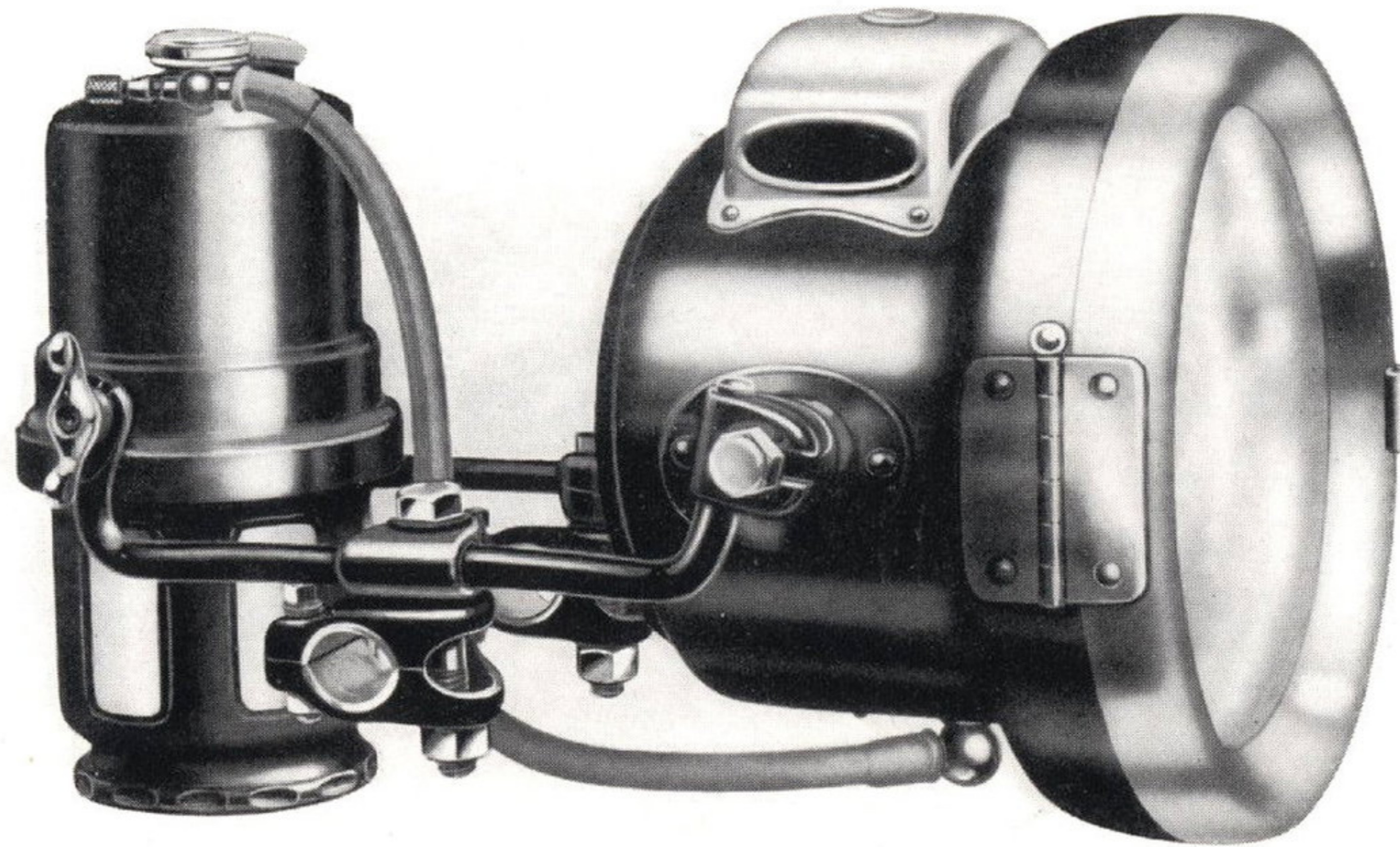

This Projector can be swung round for inspection purposes without being removed from Bracket.

LUCAS

"KING OF THE ROAD" PROJECTOR SET No. 472S

(SPORTS MODEL)

No. 472S is a Sports Model Projector Set. It is fitted with a genuine **Mangin Lens Mirror**, and the Projector is mounted well forward by means of our Girder Brackets No. 48, which are strong and rigid.

Its powerful, penetrative light is projected for a considerable distance ahead, enabling the rider to maintain a high average speed with safety.

The Generator can be fitted to bars or down tubes, as required, by its adjustable bracket, and the carbide container is attached by our patented quick-action fixing.

No.							CASH PRICE
472S	COMPLETE SET —includes Projector No. 472, Projector Girder Brackets (No. 48) for handle-bar, Generator No. 62 with Tubing and No. 37 Generator Bracket. Ebony Black finish ..						£3 0 0
	PROJECTOR ONLY—						
No.	Height.	Weight.	Front.	Glass.	Burner.	Finish.	
472	7 $\frac{1}{4}$ in.	3 $\frac{3}{4}$ lb.	7 $\frac{1}{4}$ in.	6 $\frac{1}{4}$ in.	No. 52	Ebony Black	2 0 0
	GENERATOR ONLY—						
62	Supplies gas for 4 $\frac{1}{2}$ hours. Ebony Black finish						15 0
37	GENERATOR BRACKET for No. 62 Generator						2 6

Ebony Black is the standard finish, but Nickel Plated can be supplied if ordered.

POSTAGE EXTRA.

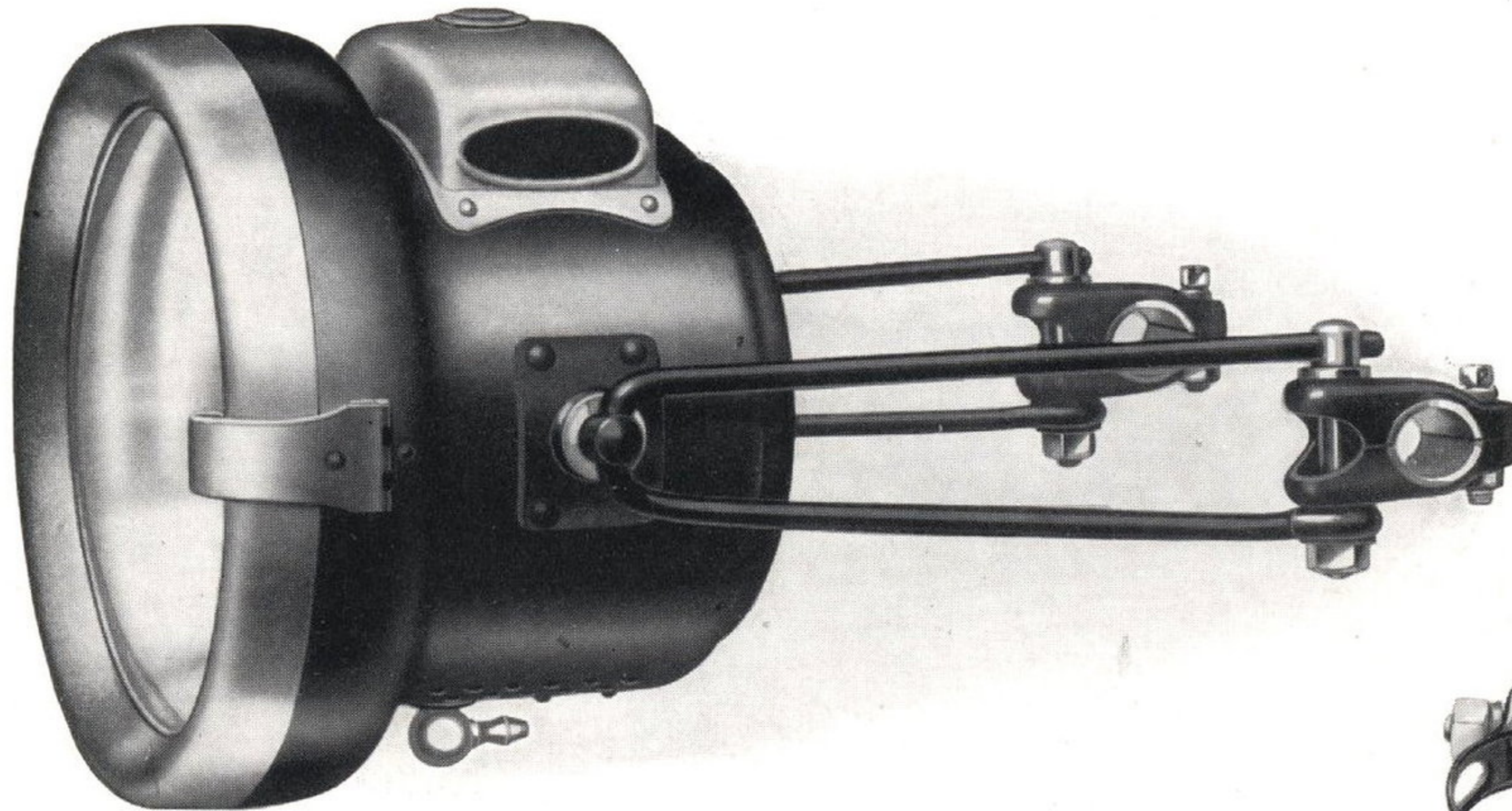

" KING OF THE ROAD "
SET No. 472S
(SPORTS MODEL)

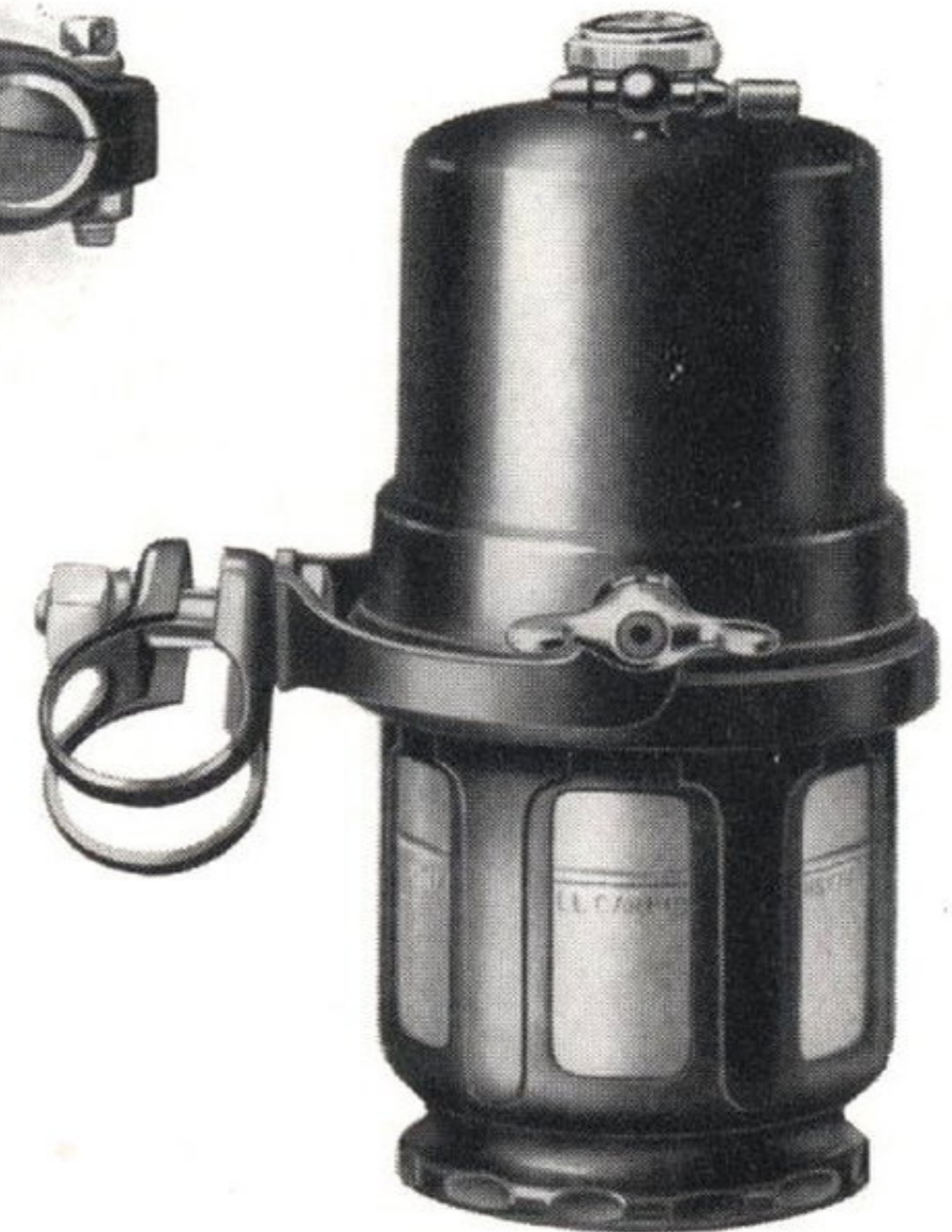

LUCAS

"KING ^{OF} THE ROAD" PROJECTOR SET No. 462

No. 462 is built on similar lines to our Motor-Car Projectors, with a special **Mangin Lens Mirror** and **Parabolic Reflector**, which project a powerful, penetrative light, enabling the rider to discern pedestrians, vehicles, or obstacles, at a considerable distance, while providing the necessary breadth of beam to illuminate the full width of the road near the rider. The flame is absolutely steady and unvarying, and is not affected by cross winds.

The Generator is of the drip-feed type, has a two-way nipple, and the fixing of the carbide container is effected by our patented method, which is the quickest imaginable. A slight turning movement serves to fix or unfix the container.

A Double Bracket, carrying the Projector and Generator on the handle-bar, is included in the price of the Set. It can be fixed to most standard machines, is adjustable for level, and will fit $\frac{7}{8}$ in. or 1 in. bars. All brackets are fitted with the new Lucas ball socket mounting, which enables the Projectors to be set correctly without strain either to the lamps or brackets.

No.							CASH PRICE
462	COMPLETE SET —includes Projector, Generator, Double Bracket (No. 61B) for handle-bar, and Tubing. Ebony Black finish						£2 10 0
	PROJECTOR ONLY —						
No.	Height.	Weight.	Front.	Glass.	Burner.	Finish.	
462	6½ in.	3 lb.	6½ in.	5 in.	No. 52	Ebony Black ..	1 10 6
	GENERATOR ONLY —						
62	Supplies gas for 4½ hours.		Ebony Black finish		15 0

Ebony Black is the standard finish, but Nickel Plated can be supplied if ordered.

POSTAGE EXTRA

"KING OF THE ROAD"
SET NO. 462
(WITH DOUBLE BRACKET)

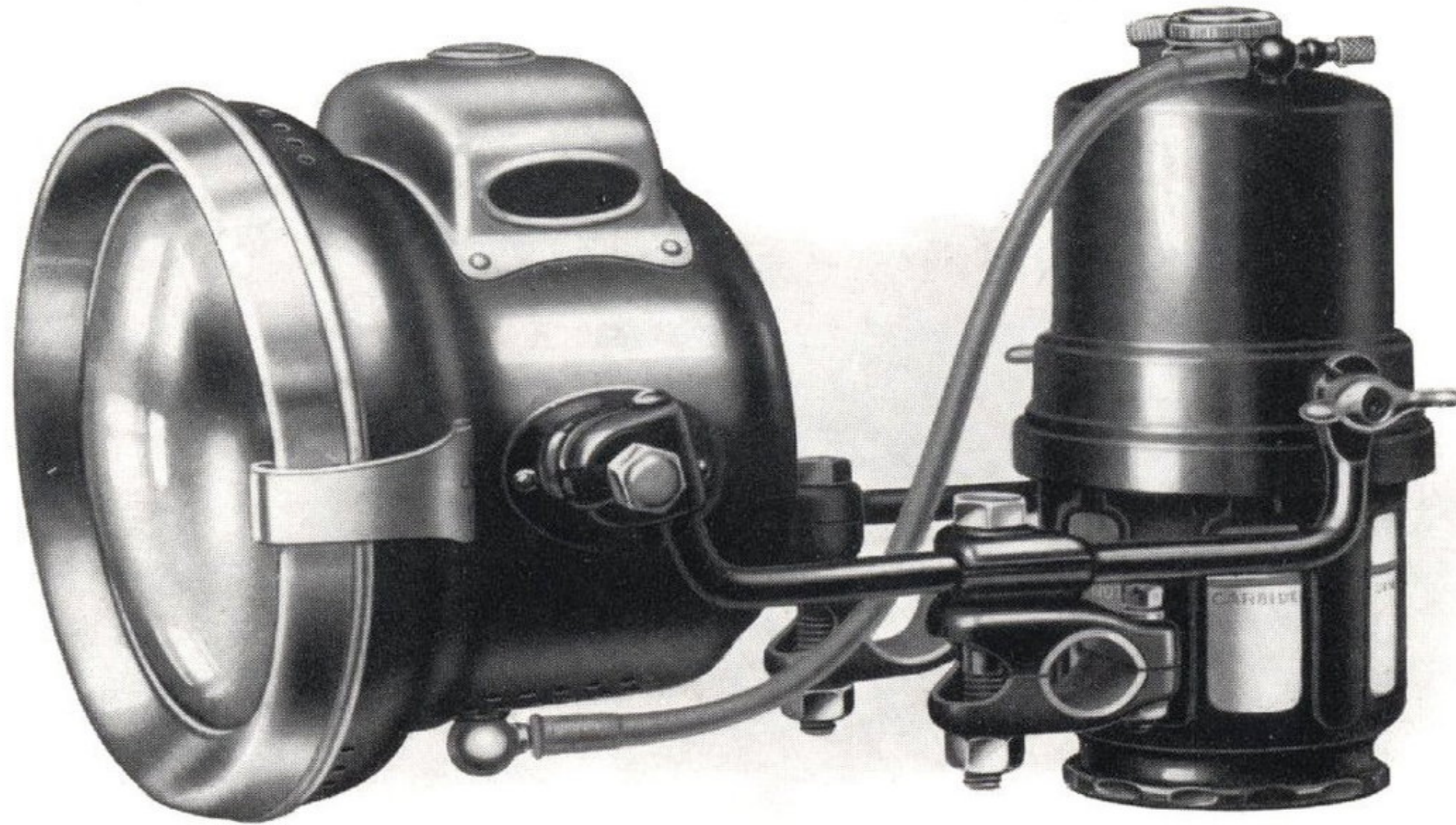
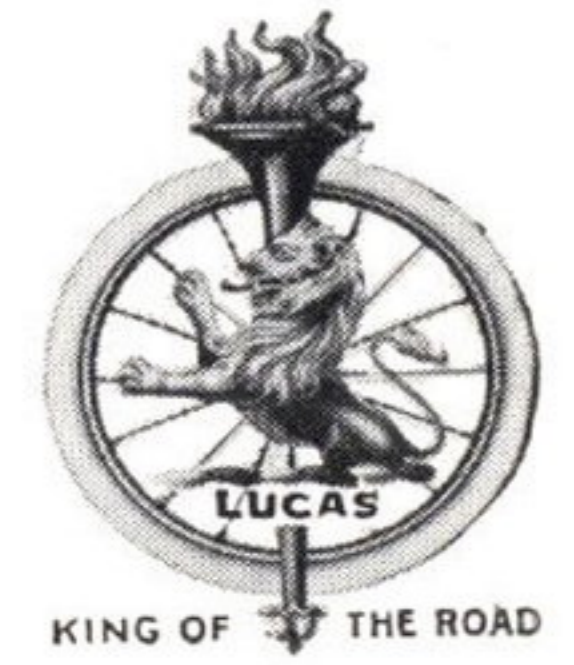

Patented side-sockets are fitted which permit the Projector to be swung round for inspection purposes without being removed from Bracket.

LUCAS "KING ^{OF} THE ROAD"

PROJECTOR SETS Nos. 462S AND 462FS

No. 462S Sports Model Projector Set (Acetylene) is fitted with a special **Mangin Lens Mirror** and **Parabolic Reflector**, which project a powerful, penetrative light for a considerable distance and give the necessary width of beam near the rider.

The Projector can be set well ahead of the handle-bars by means of our Girder Brackets No. 48, to complete the general outline of a Sports Machine.

The Generator is of the drip-feed type and is fitted with a special adjustable bracket which enables it to be fitted to the handle-bar, down tubes, etc., where required.

							CASH PRICE
No.							
462S	COMPLETE SET —includes Projector, Projector Girder Brackets (No. 48) for handle-bar, Generator (No. 62) with Tubing, and No. 37 Generator Bracket. Ebony Black finish						£2 10 0
	PROJECTOR ONLY —						
No.	Height.	Weight.	Front.	Glass.	Burner.	Finish.	
462S	6½ in.	3 lb.	6½ in.	5 in.	No. 52	Ebony Black ..	1 10 6
	GENERATOR ONLY —						
62	Supplies gas for 4½ hours. Ebony Black finish						15 0
37	GENERATOR BRACKET						2 6

This Projector can also be adapted for fitting to front forks, and is supplied as a complete Set (No. 462FS) with No. 39 Fork Brackets instead of No. 48 Girder Brackets ; otherwise the Set is similar to Nos. 462S detailed above. No. 39 Brackets are supplied to suit either $\frac{5}{8}$ in. or $\frac{3}{4}$ in. forks.

							CASH PRICE
No.							
462FS	COMPLETE SET. Finish Ebony Black						£2 10 0

Ebony Black is the standard finish, but Nickel Plated can be supplied if ordered.

POSTAGE EXTRA.

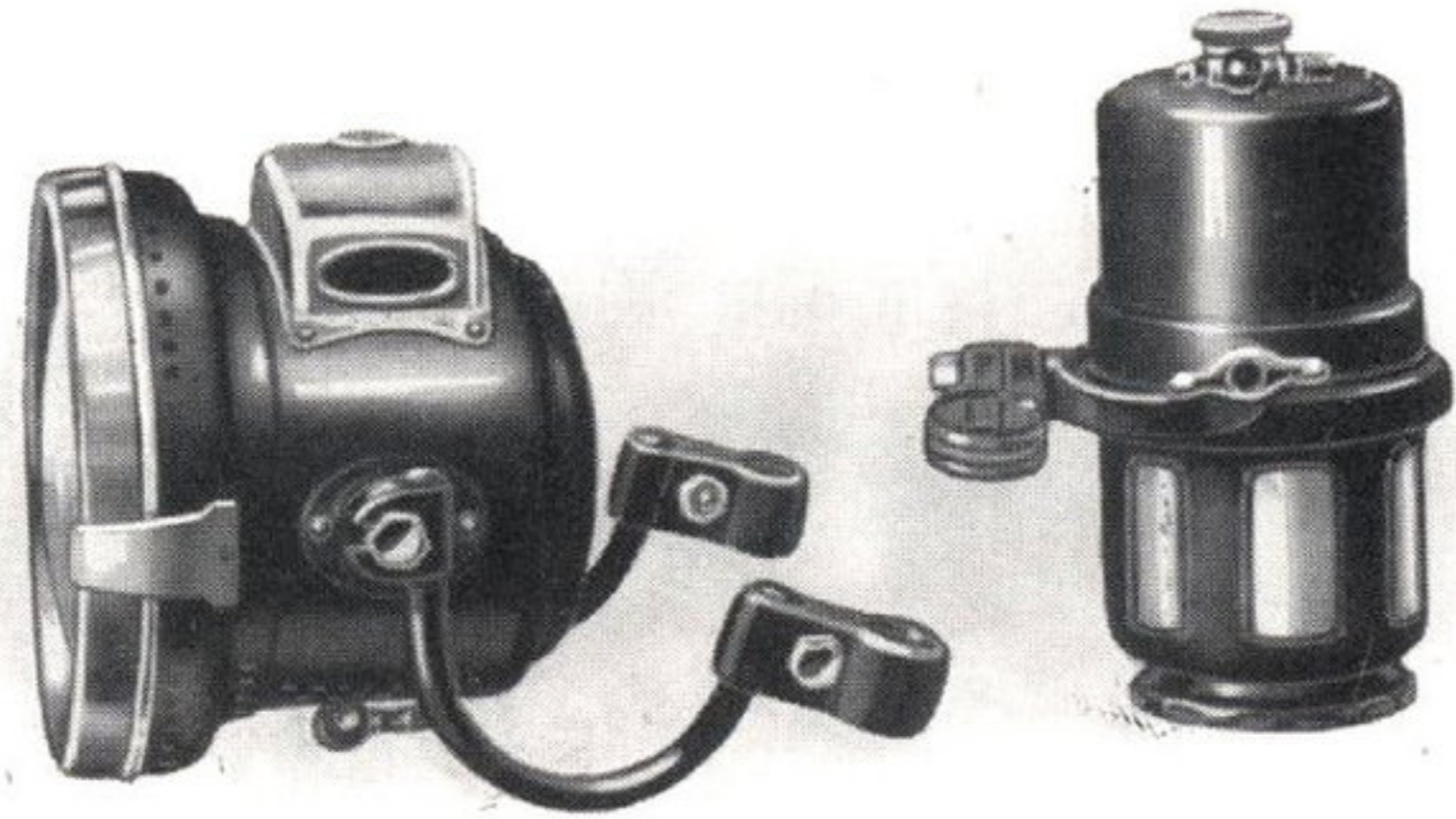

NO. 462FS SET
FOR FRONT FORKS

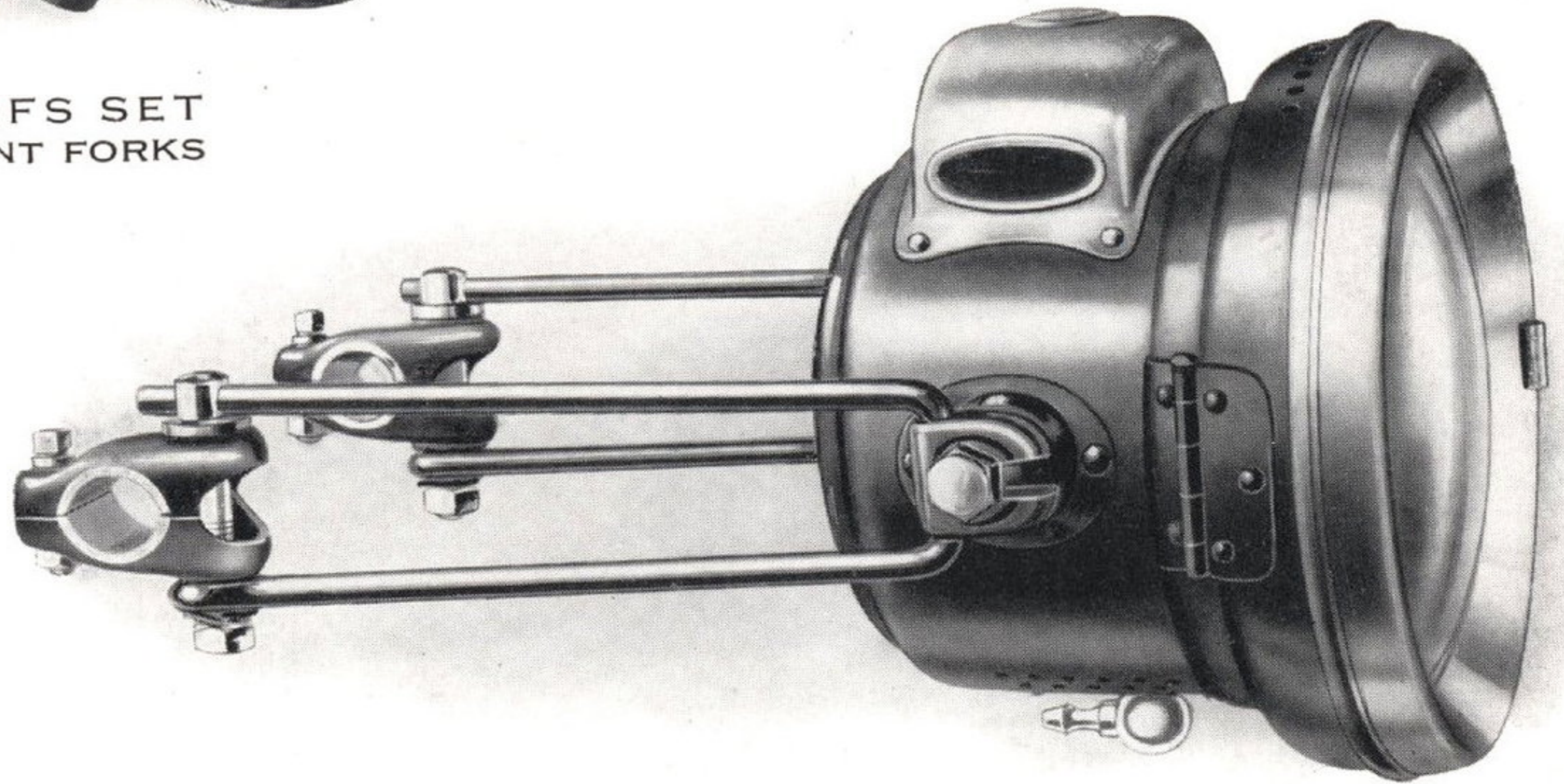

"KING OF THE ROAD"
SET No. 462S
(SPORTS MODEL)

LUCAS

"KING ^{OF} THE ROAD" PROJECTOR SET No. 420

No. 420, a new model for 1928, is a soundly constructed Projector Set, fitted with a **Silvered Mirror Reflector** optically designed to throw a steady, penetrative light a good way ahead, while at the same time the beam is sufficiently wide and divergent to light up the sides of the road. It is fitted with a **Reflector Extension**. The double bracket is adjustable to allow the lamp to be tilted to the desired angle for the best projection of the light. The Generator is of the drip-feed type, has a two-way nipple and our patented quick-action fixing.

No.		CASH PRICE
420	COMPLETE SET —includes Projector, Generator, Double Bracket No. 41B for handle-bar, and Tubing, Ebony Black finish	£1 11 0

PROJECTOR ONLY—

No.	Height.	Weight.	Front.	Glass.	Burner.	Finish.		
420	6½ in.	2¼ lb.	6½ in.	5 in.	No. 40	Ebony Black	..	18 6

GENERATOR ONLY—

42	Supplies gas for 4½ hours.	Ebony Black finish		10 0
-----------	----------------------------	--------------------	----	----	----	--	-------------

Ebony Black is the standard finish, but Nickel Plated can be supplied if ordered.

POSTAGE EXTRA.



"KING OF THE ROAD"
SET No. 420
(WITH DOUBLE BRACKETS)

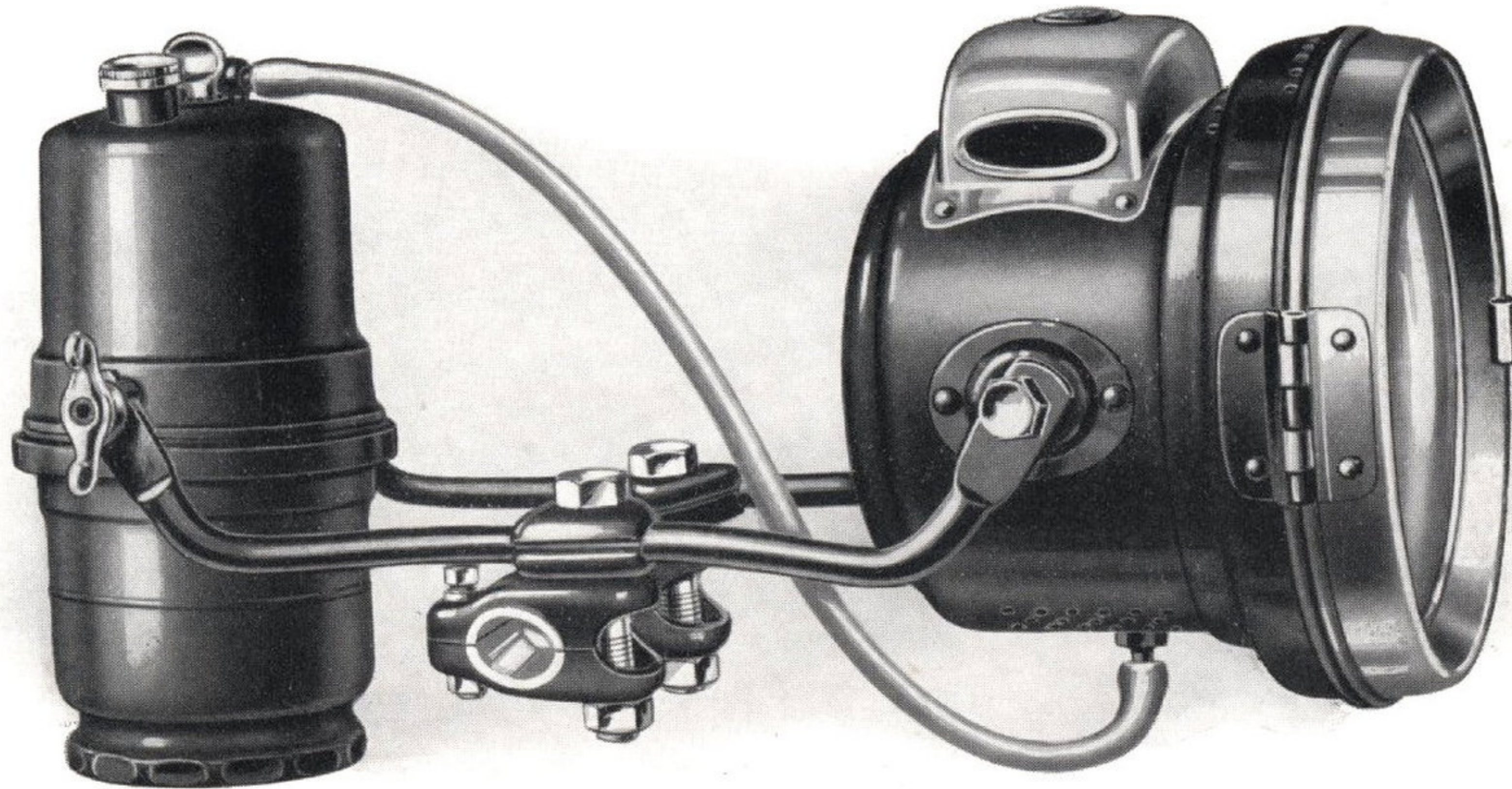

LUCAS "KING OF THE ROAD"

PROJECTOR SETS Nos. 420S AND 420FS

No. 420S, a new **Sports Model Projector Set**, is similar to the model described on pages 10-11, but is fitted with our Girder Brackets which enable the Projector to be mounted well forward, completing the appearance of a Sports Machine. The drip-feed Generator is of ample capacity, and is supplied with a stirrup bracket, making it suitable for fixing to down tubes, etc., where required.

No.							CASH PRICE
420S	COMPLETE SET —includes Projector, Projector Girder Brackets (No. 48) for handle-bar, Generator No. 42, with Tubing, and No. 37 Generator Bracket. Ebony Black finish						£1 12 6
PROJECTOR ONLY—							
No. 420	Height. 6½ in.	Weight. 2¼ lb.	Front. 6½ in.	Glass. 5 in.	Burner. No. 40	Finish. Ebony Black	.. 18 6
GENERATOR ONLY—							
42	Supplies gas for 4½ hours. Ebony Black finish					10 0
37	GENERATOR BRACKET	2 6

Projector No. 420S can also be adapted for fitting to front forks, and is supplied as a complete Set (**No. 420FS**) with No. 39 Fork Brackets instead of No. 48 Girder Brackets; otherwise the Set is similar to No. 420S detailed above. No. 39 Brackets are supplied to suit either $\frac{5}{8}$ in. or $\frac{3}{4}$ in. forks.

No.							CASH PRICE
420FS	COMPLETE SET. Ebony Black finish						£1 12 6

Ebony Black is the standard finish, but Nickel Plated can be supplied if ordered.

POSTAGE EXTRA

" KING OF THE ROAD "
SET NO. 420S
(SPORTS MODEL)

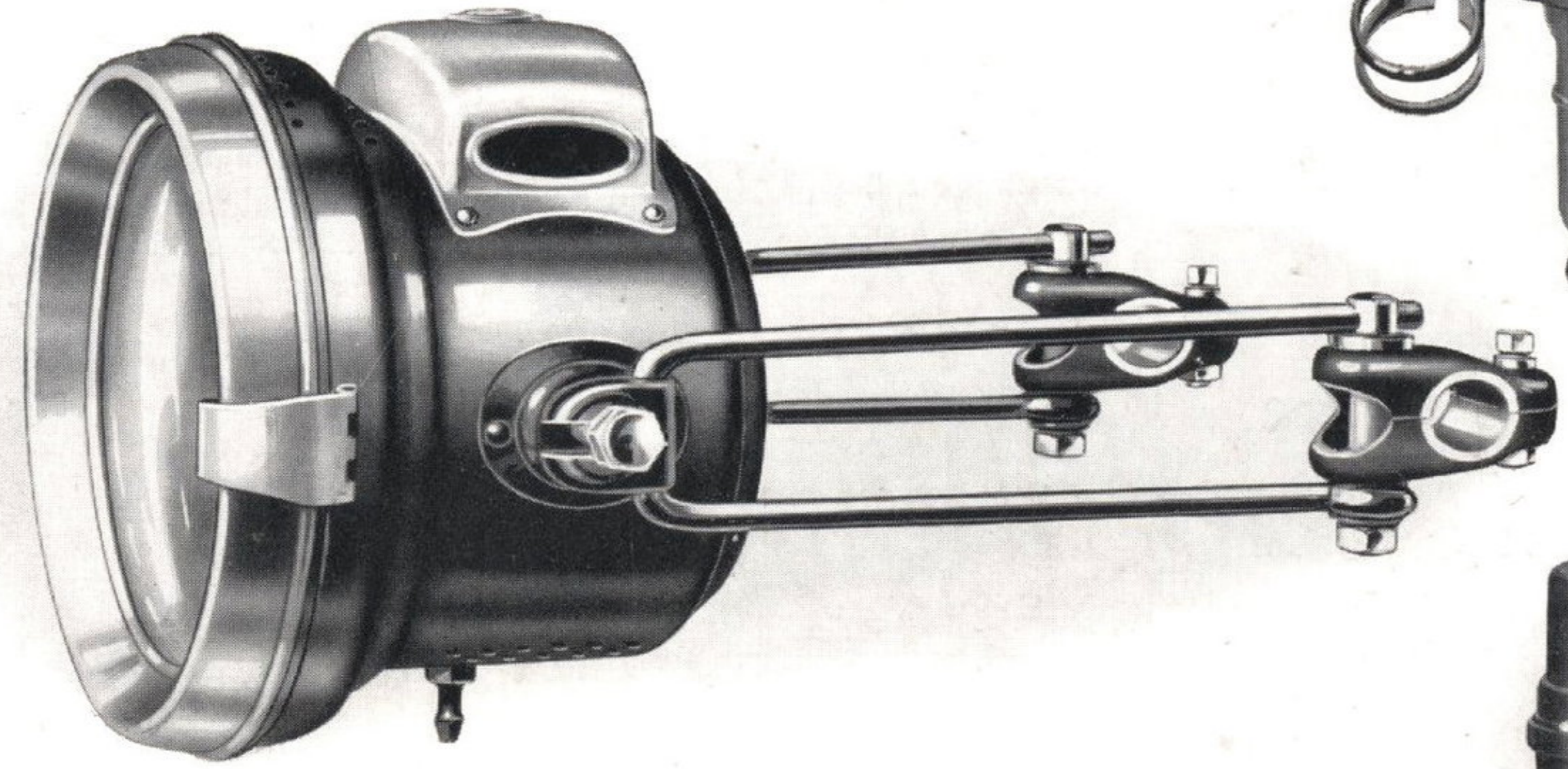

No. 420FS SET
FOR FRONT FORKS

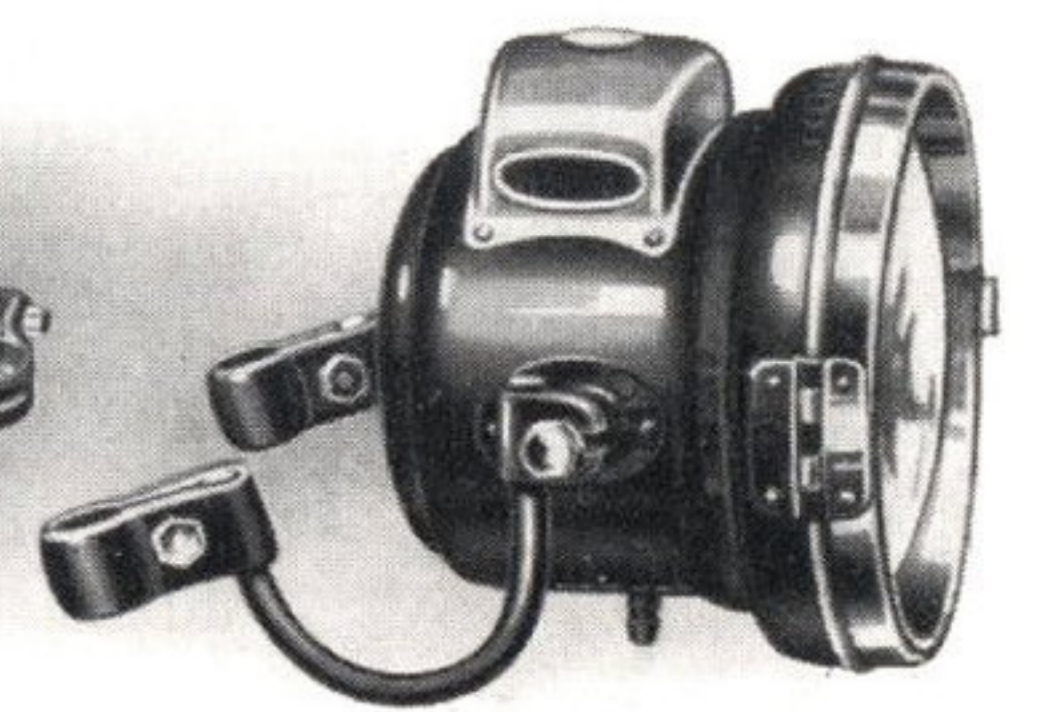

LUCAS

"KING OF THE ROAD" PROJECTOR SET No. 320

This new Acetylene Set has a Double Bracket, and is designed for fixing on the handle-bar.

The Projector is fitted with a **Silvered Mirror Reflector** and **Reflector Extension**, and can be readily adjusted to throw the light on the road where required.

The Generator is of ample capacity and has our patented fixing, a slight turning movement enabling it to be quickly fixed or unfixed. It is of the drip-feed type, giving a steady supply of gas and, therefore, even illumination. All brackets are fitted with the new Lucas ball socket mounting, which enables the Projectors to be set correctly without strain either to the lamps or brackets.

No.							CASH PRICE
320	COMPLETE SET —includes Projector, Generator No. 32, Double Bracket (No. 21B) for handle-bar, and Tubing. Ebony Black finish						£1 1 0
	PROJECTOR ONLY —						
No.	Height.	Weight.	Front.	Glass.	Burner.	Finish.	
320	6 in.	1 $\frac{3}{4}$ lb.	5 in.	4 $\frac{1}{4}$ in.	No. 40	Ebony Black ..	11 6
	GENERATOR ONLY —						
32	Supplies gas for 4 $\frac{1}{2}$ hours. Ebony Black finish						8 6

Ebony Black is the standard finish, but Nickel Plated can be supplied if ordered.

POSTAGE EXTRA.



“ KING OF THE ROAD ”
SET NO. 320
(WITH DOUBLE BRACKET)

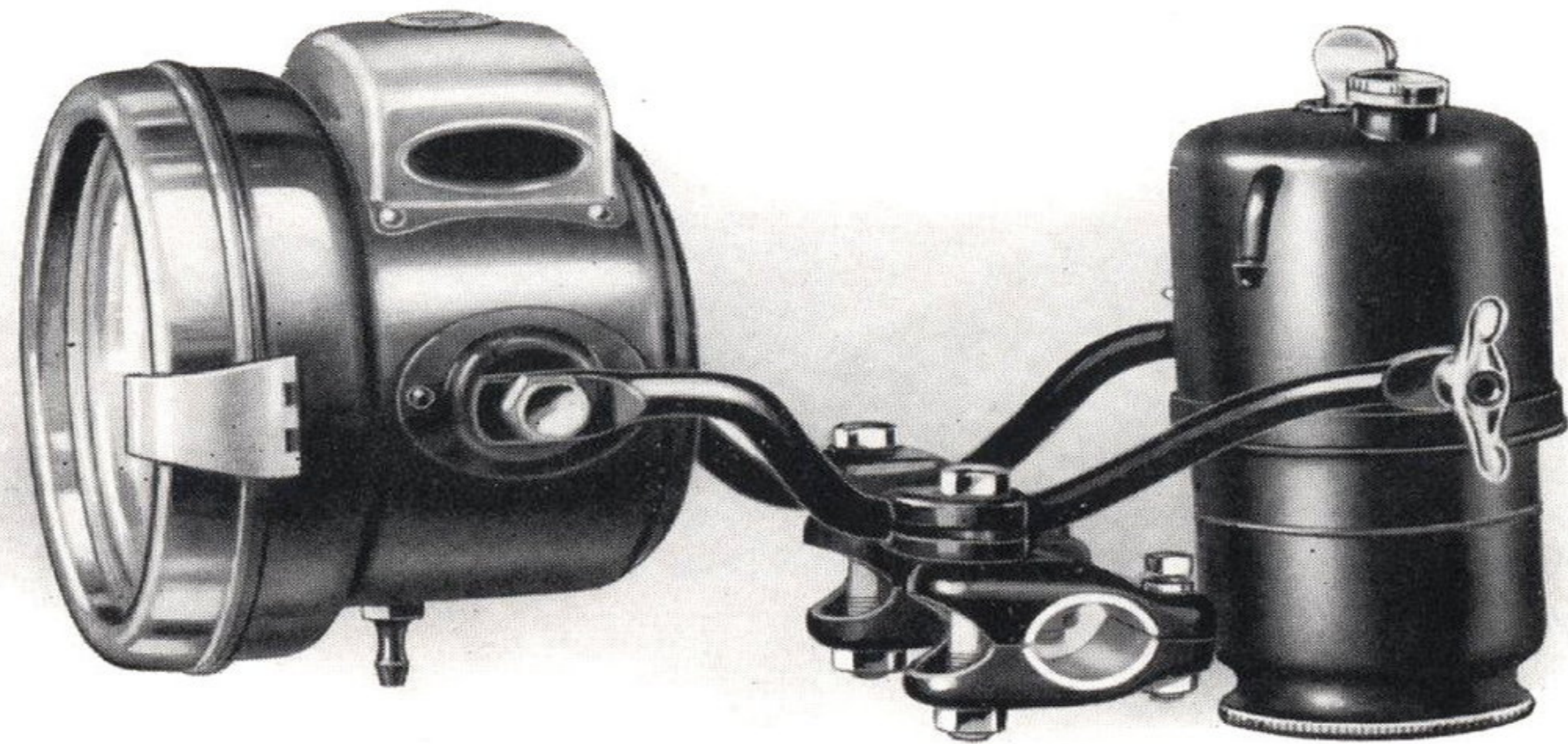

LUCAS "KING ^{OF} THE ROAD"

PROJECTOR SETS Nos. 320S AND 320FS

No. 320S Sports Model Projector Set (Acetylene) is fitted with a **Silvered Mirror Reflector** and **Reflector Extension**. It projects a powerful, penetrative light for a considerable distance, and gives the necessary width of beam near the rider.

Our Projector Girder Brackets, No. 48, enable the Projector to be set well ahead of the handle-bars, making it a very attractive Set for medium-weight Sports Machines.

The Generator No. 32, of the drip-feed type, is supplied with this Set, and is fitted with our special generator stirrup bracket No. 37. This adjustable bracket allows the Generator to be fitted to the handle-bars, down tubes, etc., where required.

No.							CASH PRICE
320S	COMPLETE SET —includes Projector, Projector Girder Brackets (No. 48) for handle-bar, Generator No. 32, with Tubing, and No. 37 Generator Bracket. Ebony Black finish						£1 2 6
	PROJECTOR ONLY —						
No.	Height.	Weight.	Front.	Glass.	Burner.	Finish.	
320	6 in.	1 $\frac{3}{4}$ lb.	5 in.	4 $\frac{1}{4}$ in.	No. 40	Ebony Black	11 6
32	GENERATOR ONLY —Supplies gas for 4 $\frac{1}{2}$ hours. Ebony Black finish ..						8 6
37	GENERATOR BRACKET						2 6

This Projector can also be adapted for fitting to front forks, and is supplied as a complete Set (**No. 320FS**) with No. 39 Fork Brackets instead of No. 48 Girder Brackets; otherwise the Set is similar to No. 320S detailed above. No. 39 Brackets are supplied to suit either $\frac{5}{8}$ in. or $\frac{3}{4}$ in. forks.

No.							CASH PRICE
320FS	COMPLETE SET. Ebony Black finish						£1 2 6

Ebony Black is the standard finish, but Nickel Plated can be supplied if ordered.

POSTAGE EXTRA.



"KING OF THE ROAD"
SET No. 320S
(SPORTS MODEL)

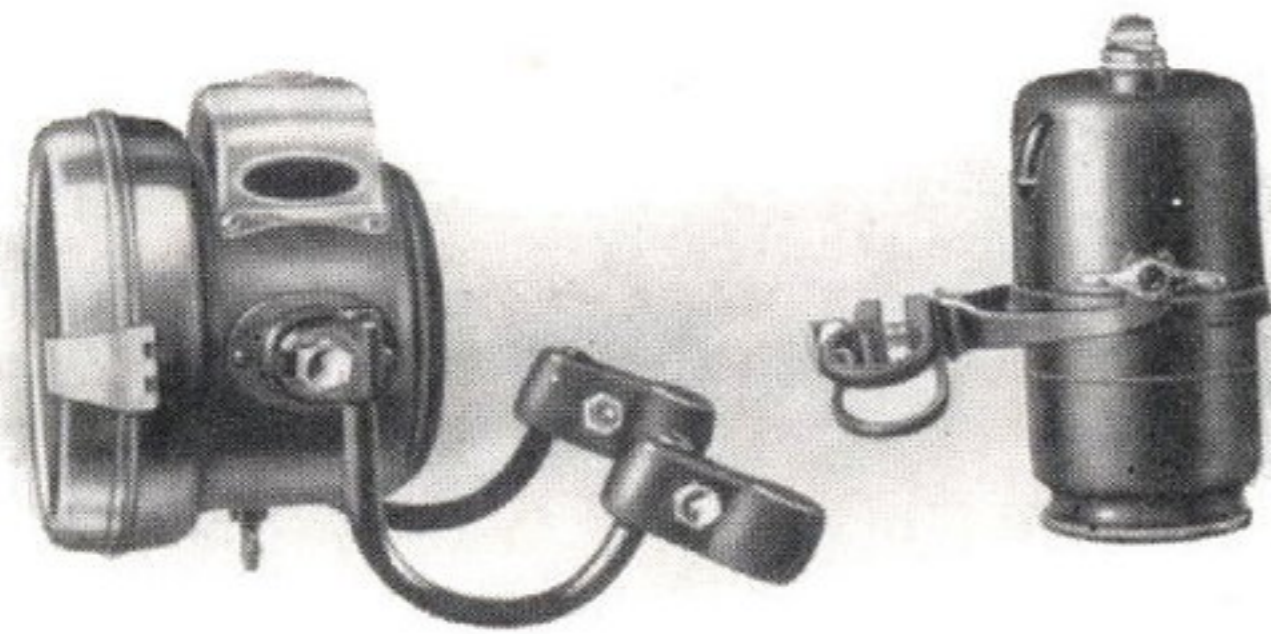
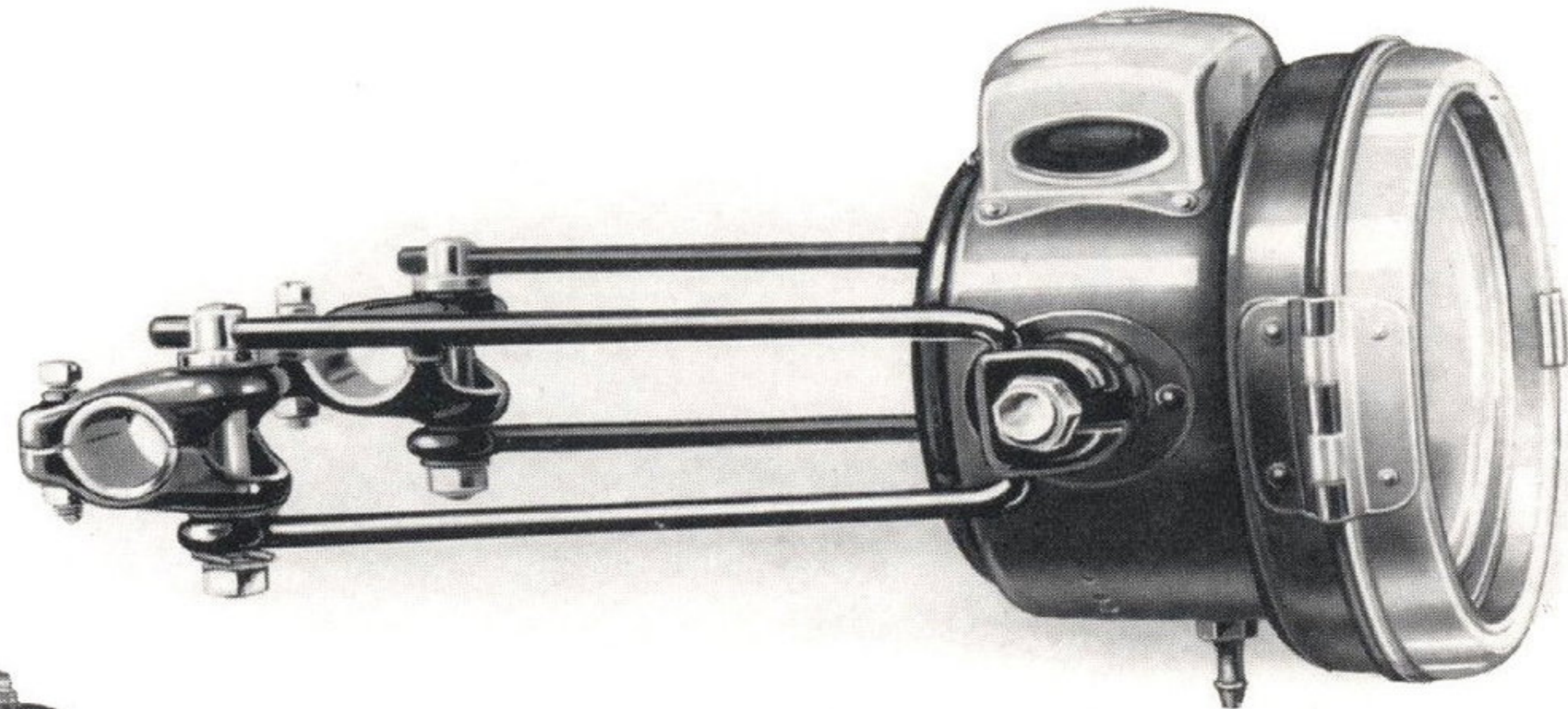

No. 320FS SET
FOR FRONT FORKS

LUCAS

SIDE-CAR LAMP WITH REAR-LIGHT No. 354

This is a popular Acetylene Lighting Set for use on Side-Cars, the Lamp being designed to throw a white light forward, and a red light to the rear by means of our **special** side reflector.

The Lamp has a back socket for a flat-tongue bracket, is fitted with a coin-slotted screw, and the Generator has a socket which fits the Lucas No. 53 Bracket, to suit $1\frac{1}{8}$ in. or $1\frac{1}{4}$ in. tubes.

A flat-tongue lamp bracket (No. 75) for fitting to the Side-Car can be supplied when required, but it is not included in the Standard Set.

No.								CASH PRICE			
354	STANDARD SET —includes Lamp, Generator, Tubing and Generator Bracket No. 53, to suit $1\frac{1}{8}$ in. or $1\frac{1}{4}$ in. tubes. Ebony Black finish							£1	2	6	
LAMP ONLY—											
No.	Height.	Weight.	Front.	Glass.	Burner.	Finish.					
354	$4\frac{1}{4}$ in.	14 oz.	$4\frac{1}{4}$ in.	$3\frac{1}{4}$ in.	No. 53	Ebony Black	12	0	
54	GENERATOR —Supplies gas for 3 hours. Ebony Black finish					8	6		
53	GENERATOR BRACKET , Ebony Black finish					2	6	
No.											
75	LAMP BRACKET , Ebony Black finish, for No. 354 Lamp							1	0

Ebony Black is the standard finish, but Nickel Plated can be supplied if ordered.

POSTAGE EXTRA.



LUCAS
SIDE-CAR
LAMPSET
No. 354

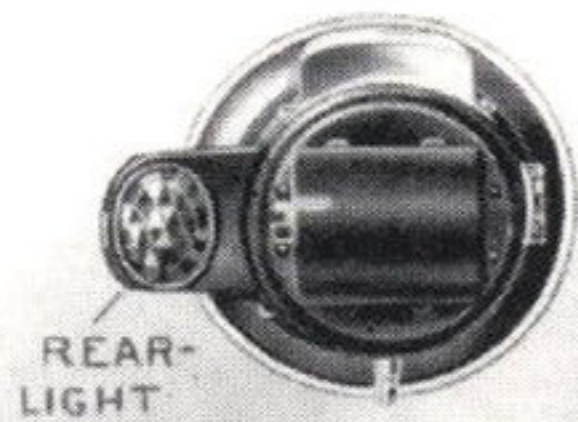

REAR-
LIGHT

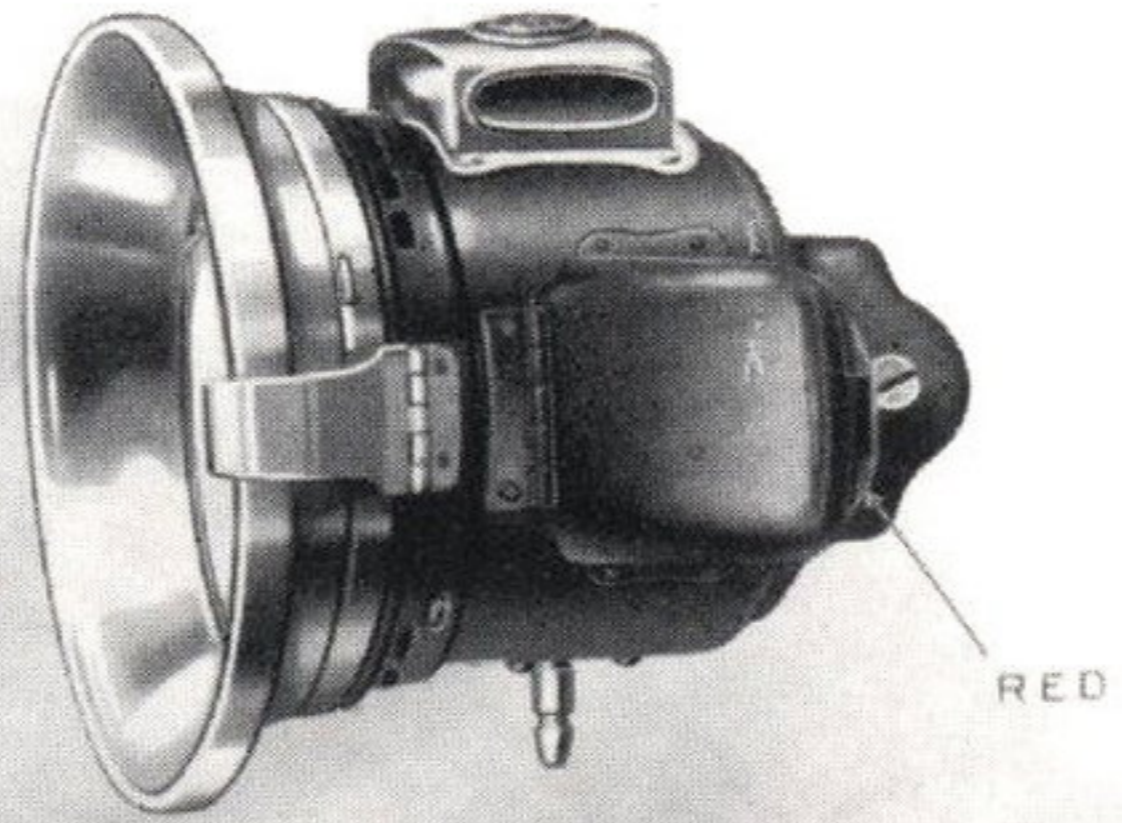

RED

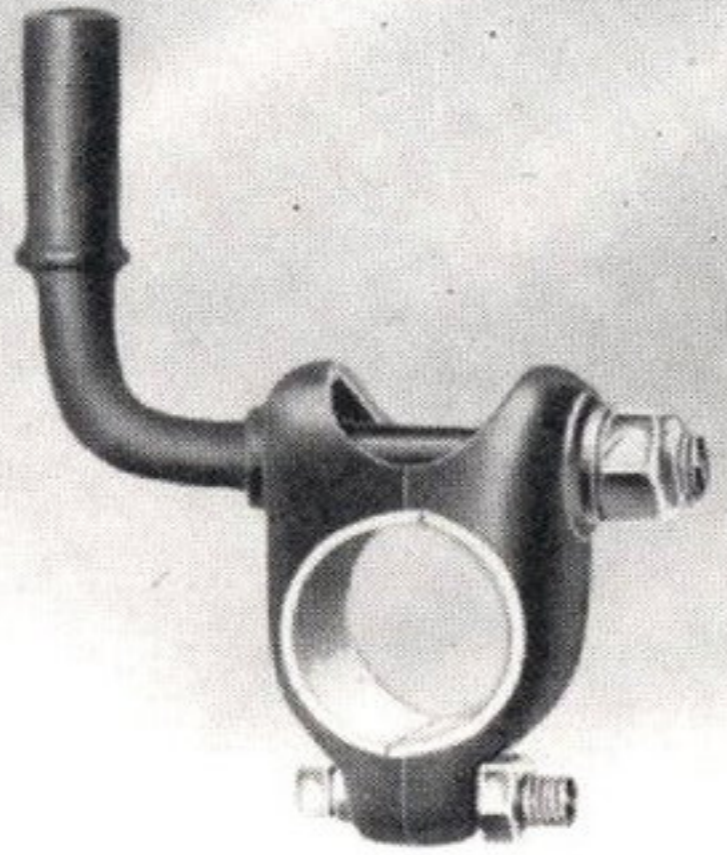

LAMP BRACKET
No. 75.

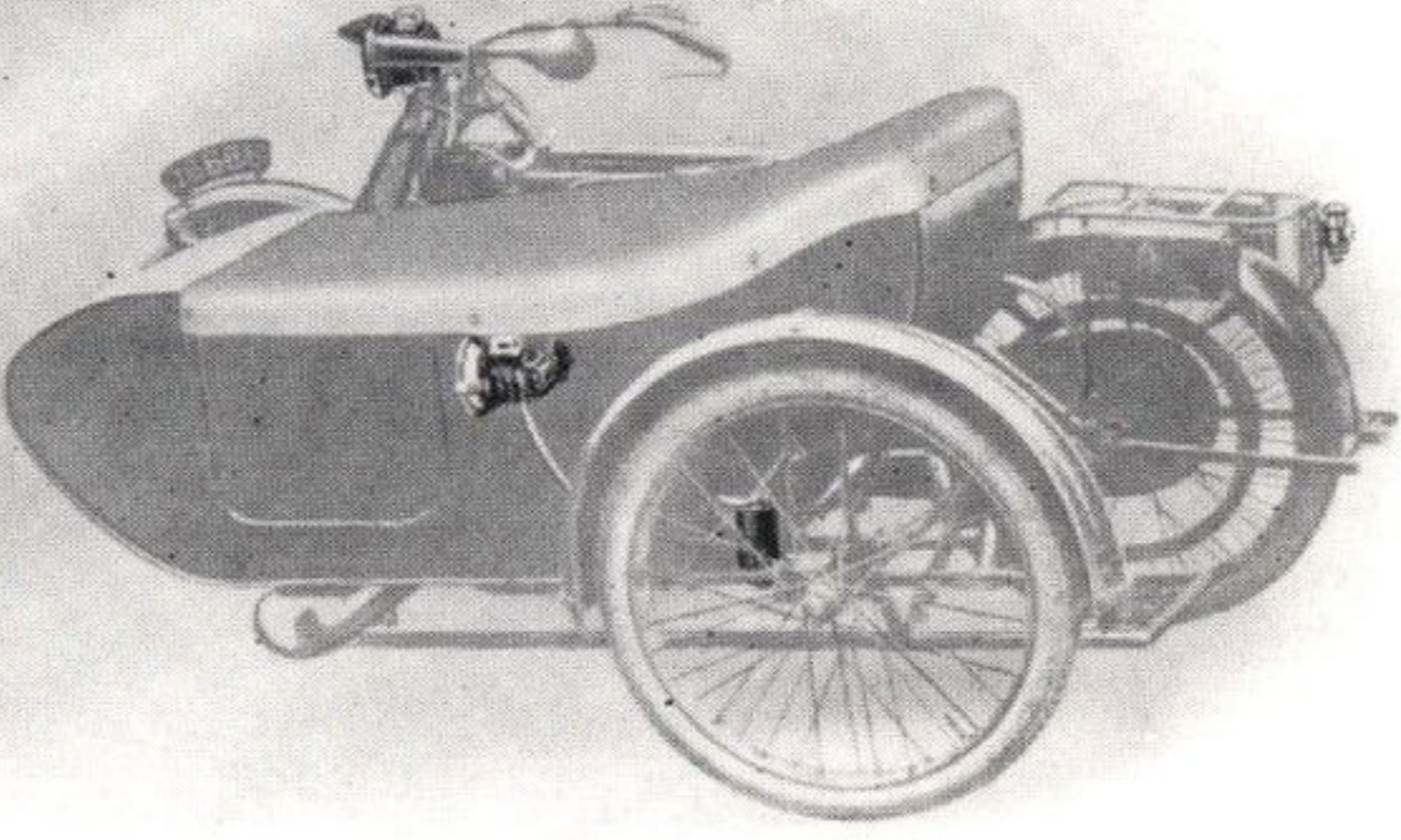

KING OF THE ROAD

LUCAS

SIDE-CAR LAMP WITH REAR-LIGHT

No. 350

No. 350 Side-Car Lamp is fitted with an Aluminium Reflector. It throws a white light forward, and shows a red light to the rear through the back of the Lamp and Bracket.

The Lamp and Bracket are combined and can be affixed to the Side-Car bodywork by means of a plate bolted up from the inside.

The Generator is of the drip-feed type and will supply sufficient gas for the No. 350 Lamp to burn 3 hours. It has a socket to take the No. 53 Generator Bracket, which fits $1\frac{1}{8}$ in. or $1\frac{1}{4}$ in. tubes.

No.		CASH PRICE
350	STANDARD SET —includes Lamp, Generator, Tubing and Generator Bracket No. 53, to suit $1\frac{1}{8}$ in. or $1\frac{1}{4}$ in. tubes. Ebony Black finish	16/6

LAMP ONLY—

No.	Height.	Weight.	Front.	Glass.	Burner.	Finish.	
350	$4\frac{1}{4}$ in.	12 oz.	$4\frac{1}{8}$ in.	$3\frac{1}{4}$ in.	No. 11	Ebony Black	6/6
44	GENERATOR ONLY —Supplies gas for 3 hours.					Ebony Black finish	7/6
53	GENERATOR BRACKET , Ebony Black finish	2/6

POSTAGE EXTRA.

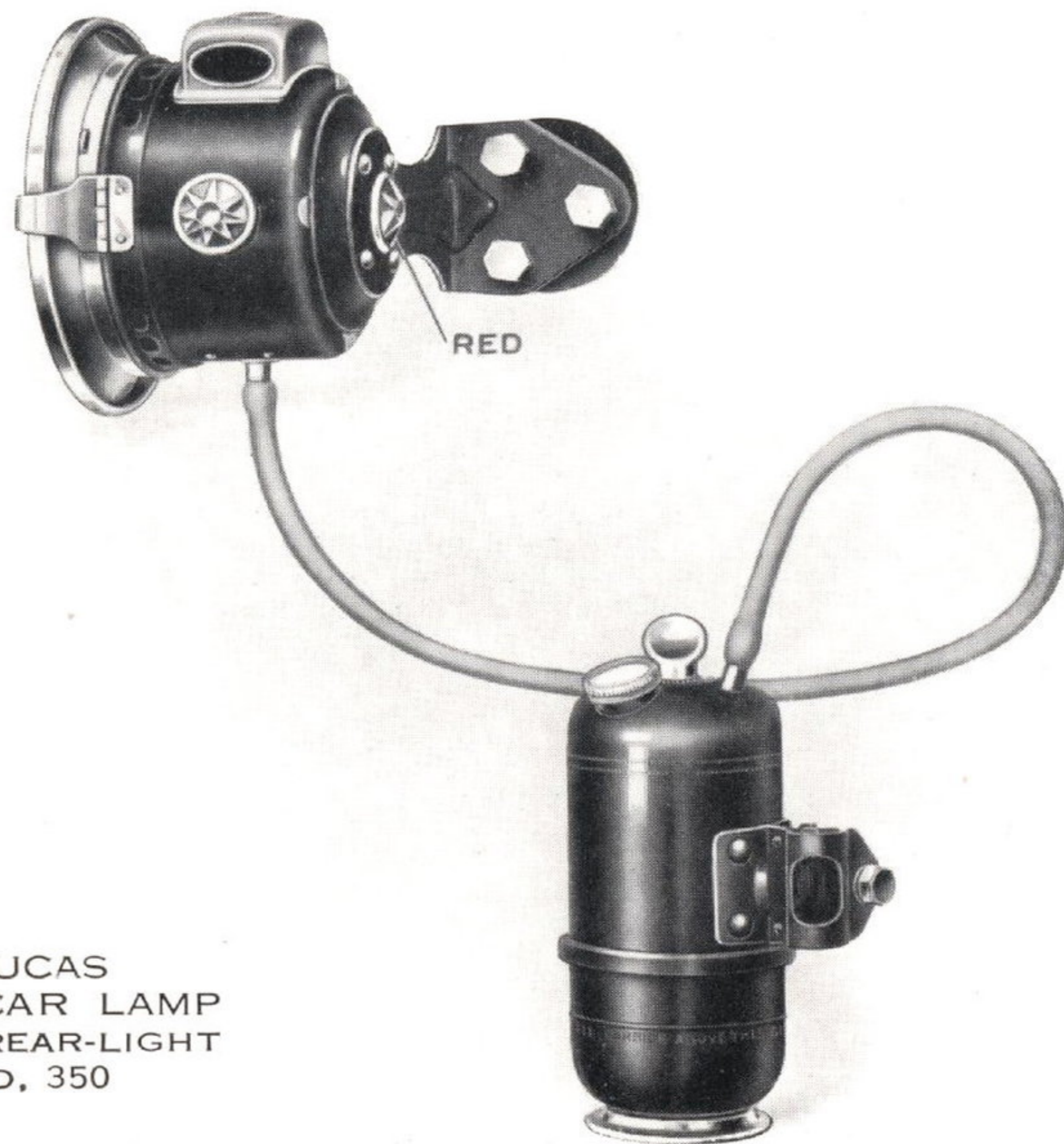

LUCAS
SIDE-CAR LAMP
WITH REAR-LIGHT
No. 350



NO. 53 BRACKET

LUCAS

TAIL LAMP No. 344 SET

(ACETYLENE)

This Tail Lamp is designed to fix on the number plate, which it illuminates by a white side light, and it shows, of course, a red light to the rear.

The gas nipple of the Lamp is now adapted for pump connection, which enables the burner to be cleaned from time to time by air pressure from a tire pump.

The Generator is conveniently fixed to the down tube under the saddle, and will supply gas for the small single-jet burner for about five hours.

The rubber tubing from the Generator to the Lamp can be neatly run along the luggage carrier, as shown in the illustration opposite, and is entirely out of the way.

		CASH PRICE
No. 344	COMPLETE SET —consists of Lamp and Generator with Bracket and Tubing	13/- set
No. 344	LAMP ONLY. Height $2\frac{1}{4}$ in. Diameter $1\frac{1}{8}$ in. Burner No. 306. Plated finish	3/6 each
No. 44	GENERATOR ONLY. Supplies gas for 5 hours. Ebony Black finish	7/6 „
No. 53	GENERATOR BRACKET, Ebony Black finish	2/6 „

POSTAGE EXTRA.

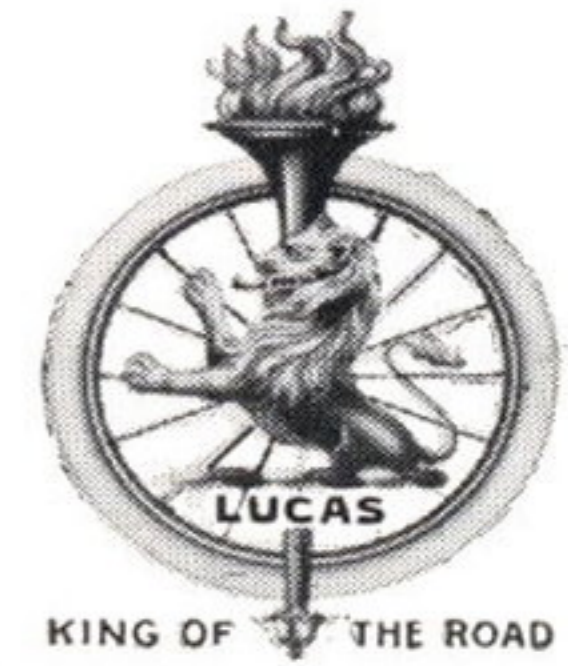

TAIL LAMP
SET No. 344

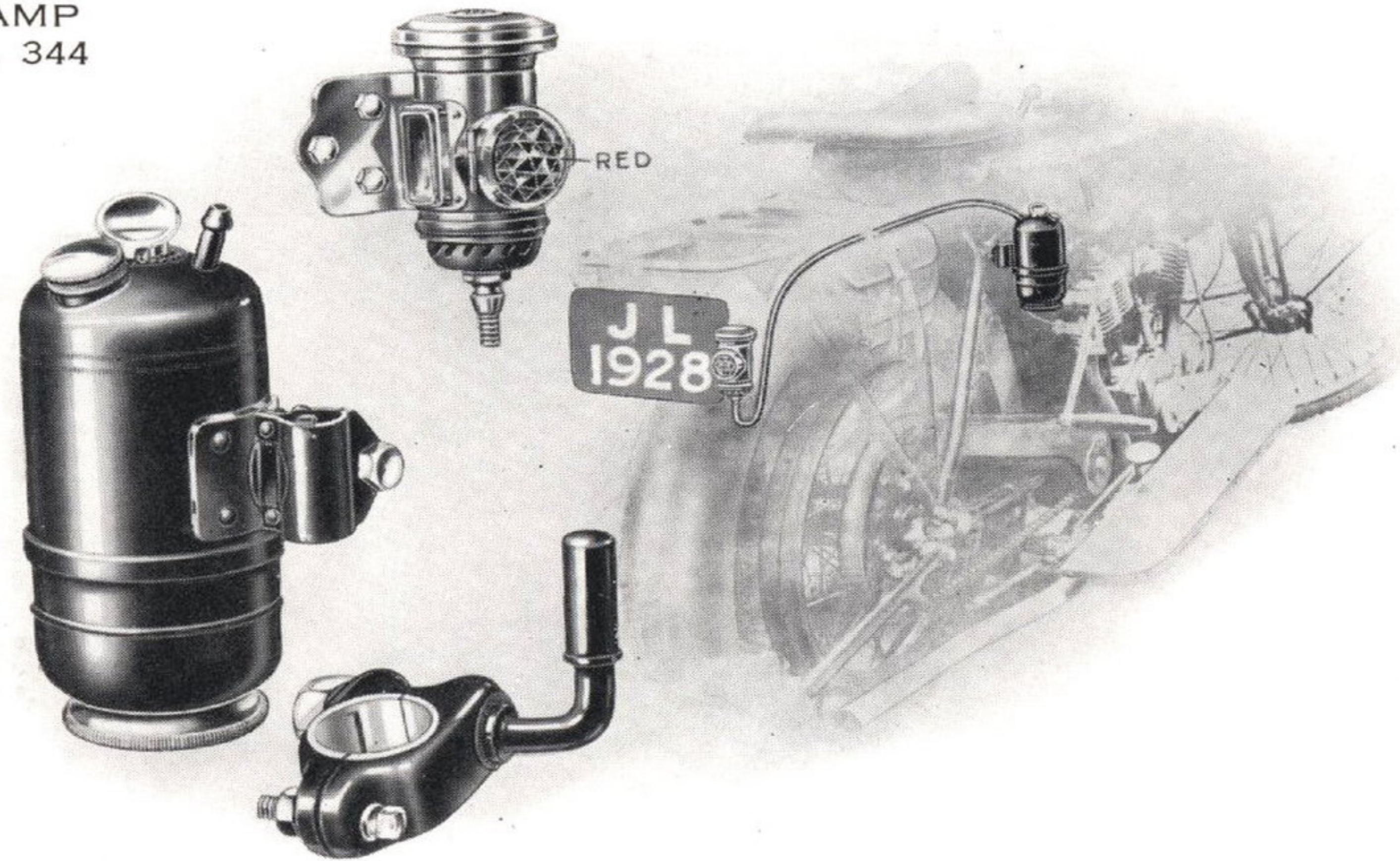

LUCAS COMPLETE SEMI-SPORTS EQUIPMENT FOR MOTOR-CYCLES

The Complete Equipment Set "D," illustrated opposite, is listed as standard by many Motor-Cycle Manufacturers.

The Complete Set comprises Projector with Brackets, Generator with Bracket, Tail Lamp and Bulb Horn, and is listed at an inclusive price.

The Projector is fitted with a Reflector Extension and a Silvered Mirror Reflector optically designed to project a powerful penetrative light a considerable distance and to give the necessary width of beam near the rider. The Brackets are designed to fit into the lugs on the front forks, making a neat method of fixing the lamp.

The Generator, of the drip-feed type, has our quick-action carbide container attachment, and its bracket makes it adaptable for fitting in the most convenient position. The two-way feed on the Generator enables the tail lamp to be supplied with gas, as well as the head lamp.

The Tail Lamp and Bulb Horn are our standard models, and are listed in detail on pages 22 and 26 respectively.

THE COMPLETE SET comprises:—

Projector (with Brackets)	No. 420.	Tail Lamp	No. 344.	
Generator	No. 42.	Bulb Horn	No. 63.	
Generator Bracket	No. 37.	Complete with necessary tubing, etc.		

	CASH PRICE
Price of Set "D," as above, Ebony Black finish	£2 0 0

The Complete Equipment Set "E" is also standard on many Light-weight Motor-Cycles. The specification is similar to Set "D," described above, but with Projector No. 320 instead of Projector No. 420, and Generator No. 32 instead of Generator No. 42.

	CASH PRICE
Price of Set "E," Ebony Black finish	£1 12 6

If a Side-Car Lamp is required to be used in conjunction with above equipment, No. 350 Set, described and illustrated on pages 20 and 21, is recommended.

POSTAGE EXTRA.



COMPLETE
SET "D"



GENERATOR NO. 42
WITH NO. 37 BRACKET

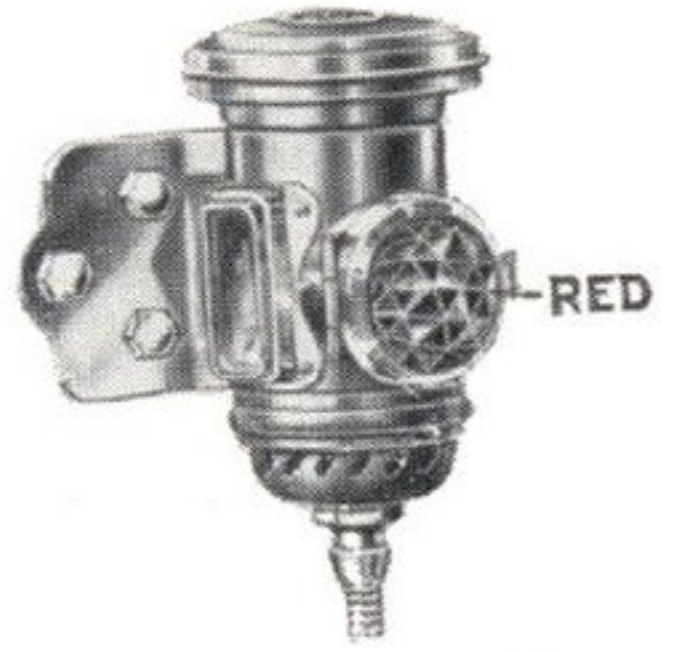

TAIL LAMP
NO. 344

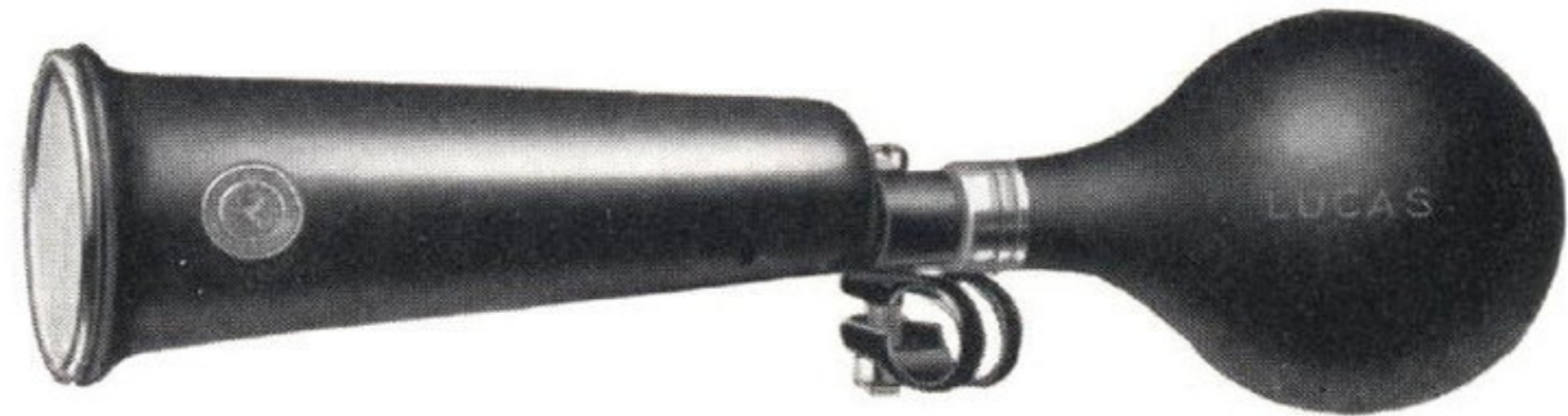

"KING OF THE ROAD"
HORN NO. 63

LUCAS

"KING ^{OF} THE ROAD" MOTOR-CYCLORNS

Nos. 32, 60, 60P, 63

Lucas Motor-Cycle Horns have a very pleasing note, of great penetration, which is unequalled for effectiveness and carrying power.

Horns Nos. 32 and 60 are fitted with the Lucas **special canvas-reinforced rubber bulbs**, which are more durable than the ordinary type, splitting at the seams being now quite unknown.

No. 32 is the most powerful motor-cycle bulb horn on the market. A suggested method of fixing is shown opposite, which places the Horn in a very convenient position. We can supply left-hand or right-hand as required.

No. 60 has the "turns" of the tube enclosed in the body of the Horn so that a compact and neat appearance is obtained, and at the same time cleaning is greatly facilitated.

No. 60P, a new model, is a similar Horn to No. 60, but has a simplified clip and a strong plain rubber bulb instead of our special canvas-reinforced bulb.

No. 63 is a smaller pattern specially designed for use on Light-weight Machines. Various improvements have been effected in this model, and for power of tone and note it is unequalled for its size.

No.		CASH PRICE EACH
32	Ebony Black finish	£1 7 6
60	Ebony Black finish	13 6
60P	Ebony Black finish	11 6
63	Smaller, Ebony Black finish	8 6

Ebony Black is the standard finish, but Nickel Plated can be supplied if ordered.

For particulars of the LUCAS MOTOR-CYCLE ELECTRIC HORN No. 3 see pages 50 and 51 of Electrical Section.

POSTAGE EXTRA.

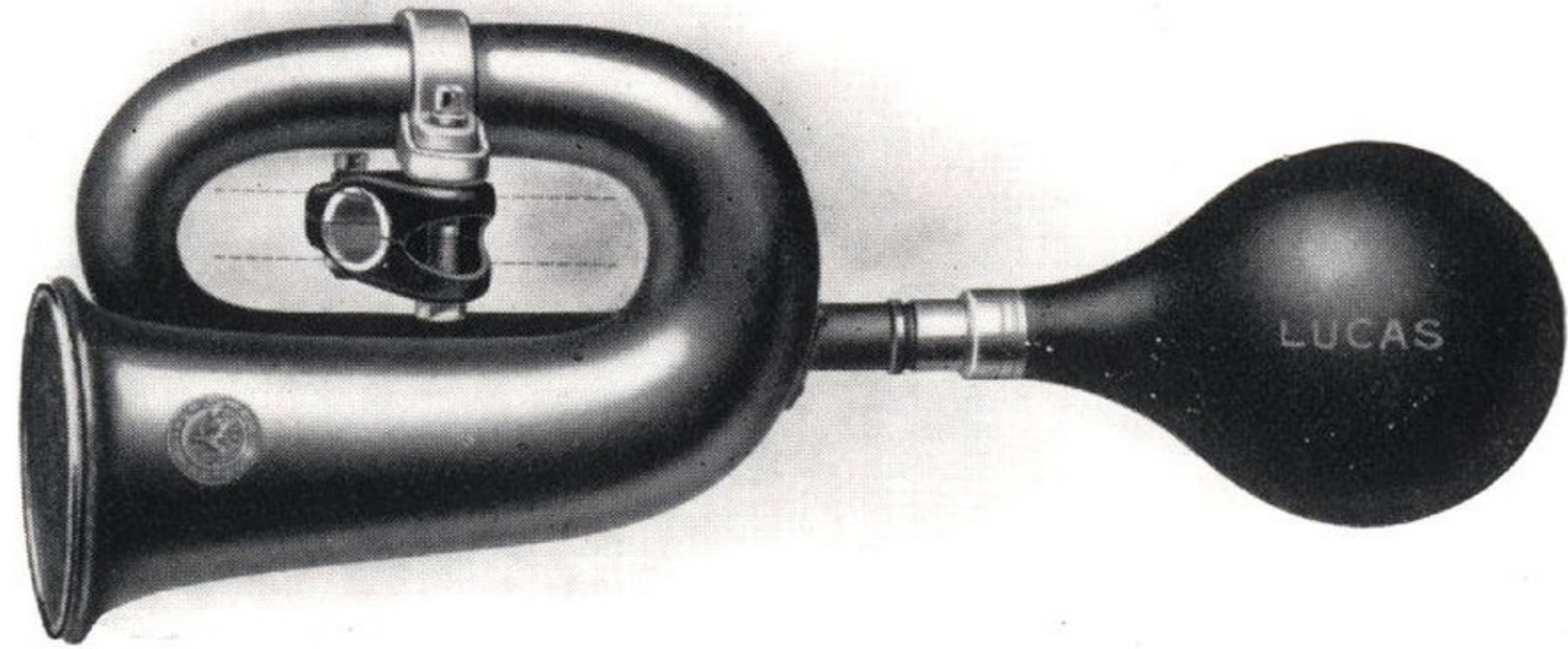

No. 32

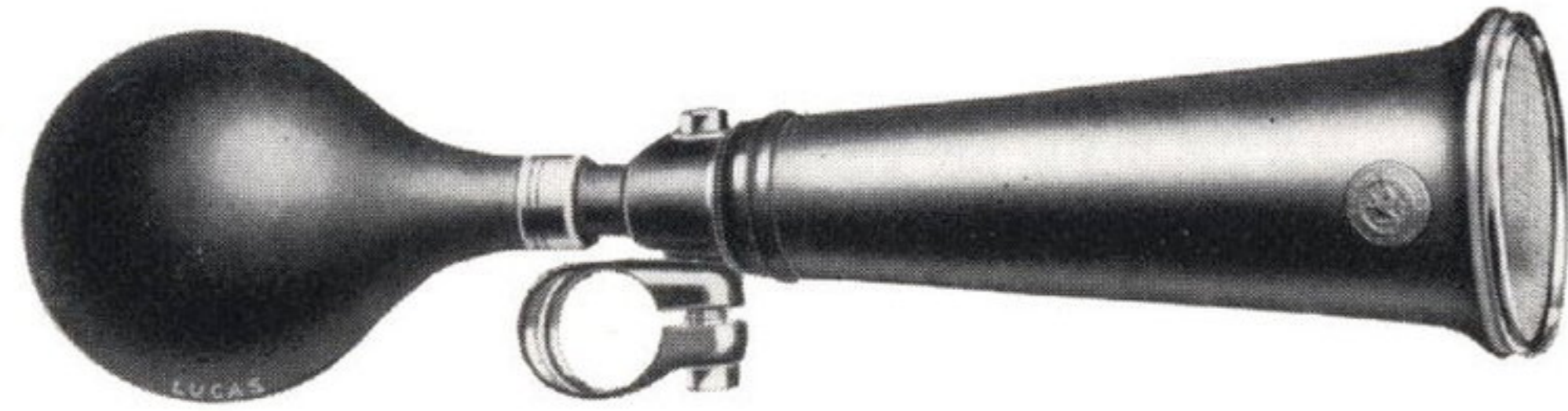

No. 60P

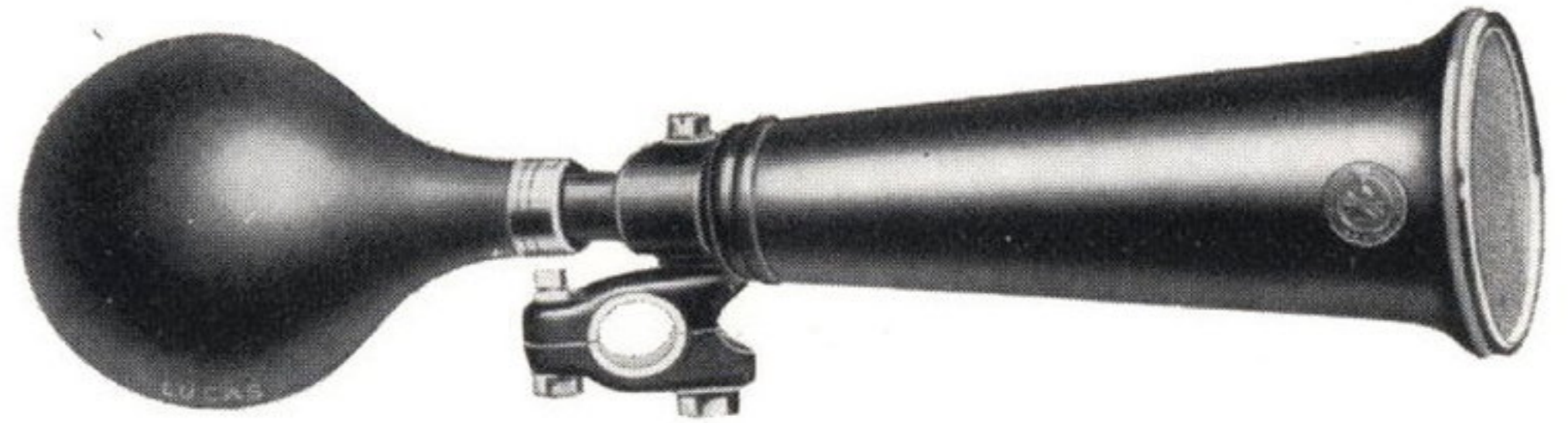

No. 60

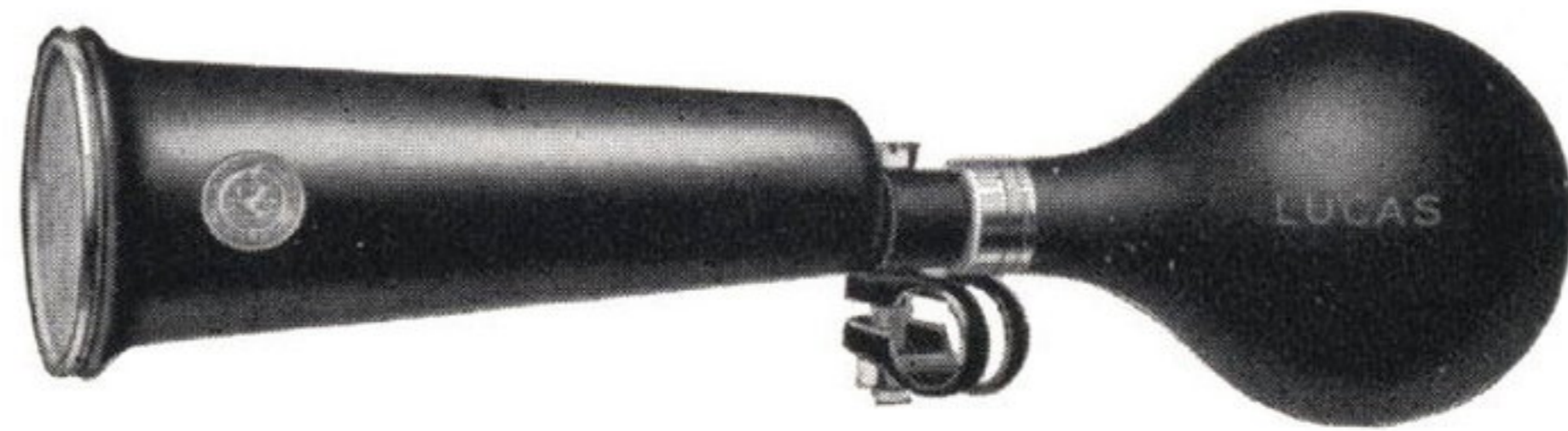

No. 63



LUCAS "KING ^{OF} THE ROAD"

"SAFETY" OBSERVATION MIRRORS Nos. 16 AND 11

Suitable for $\frac{7}{8}$ in. or 1 in. handle-bars.

No. 16 Mirror gives a wide field of vision, is adjustable in any direction, and is fitted with an ingenious locking device. When once correctly adjusted for rear observation, it may be turned over, out of the way (as illustration), and can be instantly returned to the original position without further adjustment.

To alter position of Mirror, slacken locking lever and pull Mirror forward to disengage stud. It can then be moved to the desired position, into which it falls automatically. Lock in position with the lever as shown.

No. 11 is a cheaper pattern Observation Mirror, being of more simple construction than the No. 16. This Mirror also gives a wide field of vision and is adjustable in any direction. It can be turned inwards when negotiating narrow passages.

No.	Diameter	Length of Arm.	Finish.			CASH PRICE EACH
16	3 $\frac{1}{2}$ in.	5 $\frac{3}{4}$ in.	Ebony Black (Plated parts)	10/6
11	„	„	„ „ „ „	6/6

POSTAGE EXTRA.

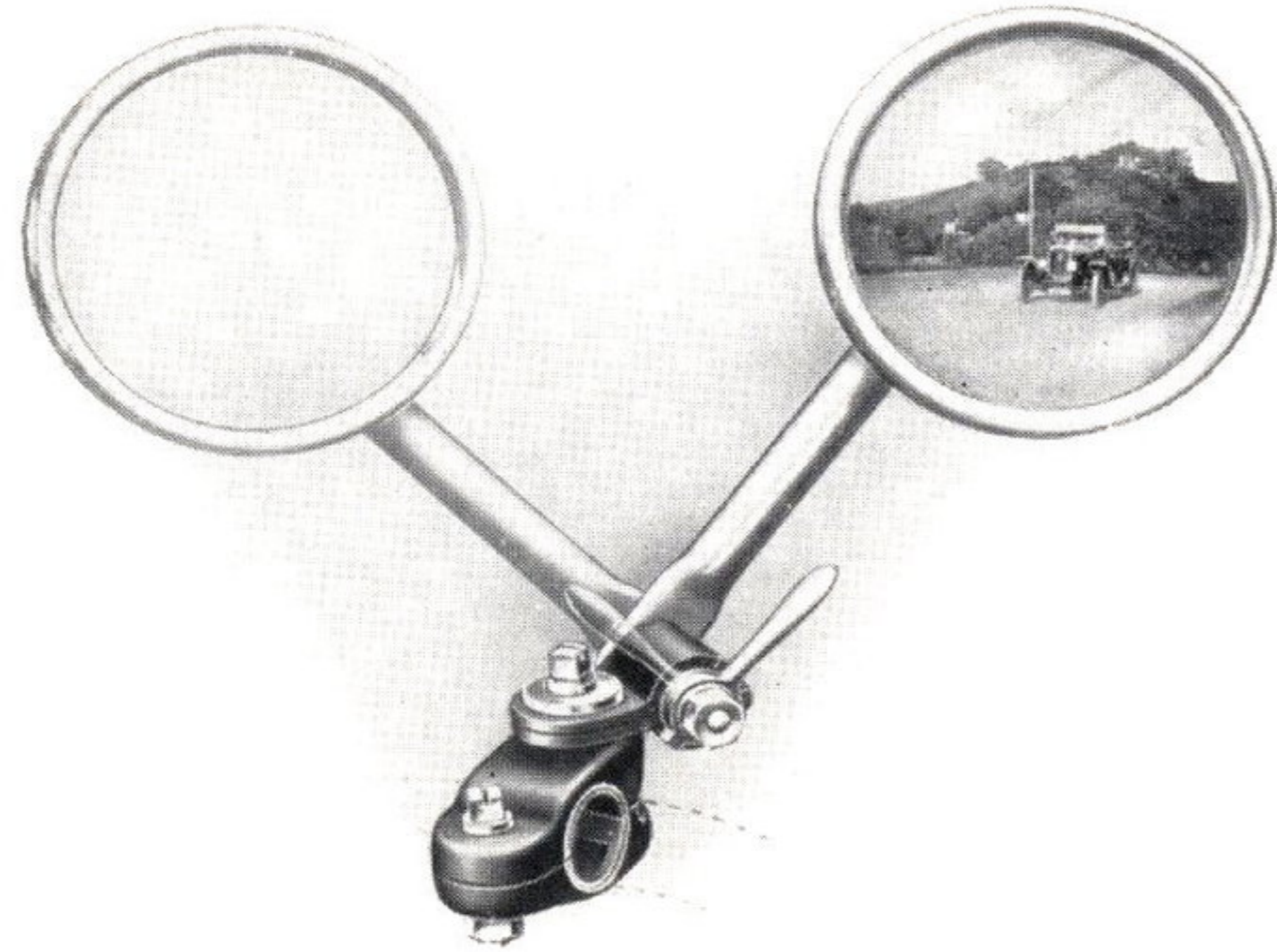

No. 16 "SAFETY" MIRROR
(WITH LOCKING DEVICE)



No. 11
"SAFETY"
MIRROR

LUCAS "GIRDER" WRENCHES

Made in three sizes : $3\frac{1}{4}$ in., $4\frac{1}{2}$ in., $7\frac{1}{4}$ in.

Each size supplied with or without patented Pipe-grip Attachment.

STRONG, LIGHT, DURABLE.

The "**Girder**" is of neat design and has a quick adjustment, responsive to the slightest touch. The shape of the jaws gives a firm, square, vice-like grip that prevents springing and slipping, releases readily and does not lock.

Each size can be supplied fitted with a Pipe-grip Attachment for holding round tubes, as illustrated.

This patented attachment is secured to the lower jaw of the wrench by two links and can be turned back out of the way when the wrench is required for ordinary nuts. The attachment has a serrated surface, and when placed in position for use on round tubes, pipes or bars, the angle of the serrations ensures a firm grip which will not slip under any pressure. A slight turn in the opposite direction instantly releases the grip.

The "**Girder**" ($4\frac{1}{2}$ in.) is useful for getting at small nuts in awkward places where a large wrench cannot be used.

The "**Girder Minor**" ($3\frac{1}{4}$ in.) is convenient for many small adjustments, such as to the magneto, and can be carried in the waistcoat pocket.

The "**Girder Major**" ($7\frac{1}{4}$ in.) is the largest "Girder" Wrench, and is very suitable for heavy adjustments. It is a particularly handy tool, and strikes one as being "just the thing" for the work, because, while being very strong, it is also light and nice to handle.

For strength, accuracy and ease of manipulation, the "Girder" Wrenches are unsurpassed, and should be found in every garage, repair shop and tool kit.

No.	Name.	Length.	Jaws Open.	Finish.						CASH PRICE EACH
90	" Girder Minor "	$3\frac{1}{4}$ in.	$\frac{5}{8}$ in.	Gun Black	2/9
90G	" " " with Pipe-grip Attachment				3/3
91	" Girder "	$4\frac{1}{2}$ in.	$1\frac{1}{8}$ in.	Gun Black	3/9
91G	" " " with Pipe-grip Attachment				4/6
93	" Girder Major "	$7\frac{1}{4}$ in.	$1\frac{7}{8}$ in.	Gun Black	6/6
93G	" " " with Pipe-grip Attachment				7/6

The Pipe-grip Attachment can be supplied separately for these Wrenches at the following prices :—For No. 90, **6d.** each ; No. 91, **9d.** each ; No. 93, **1/-** each.

POSTAGE EXTRA.

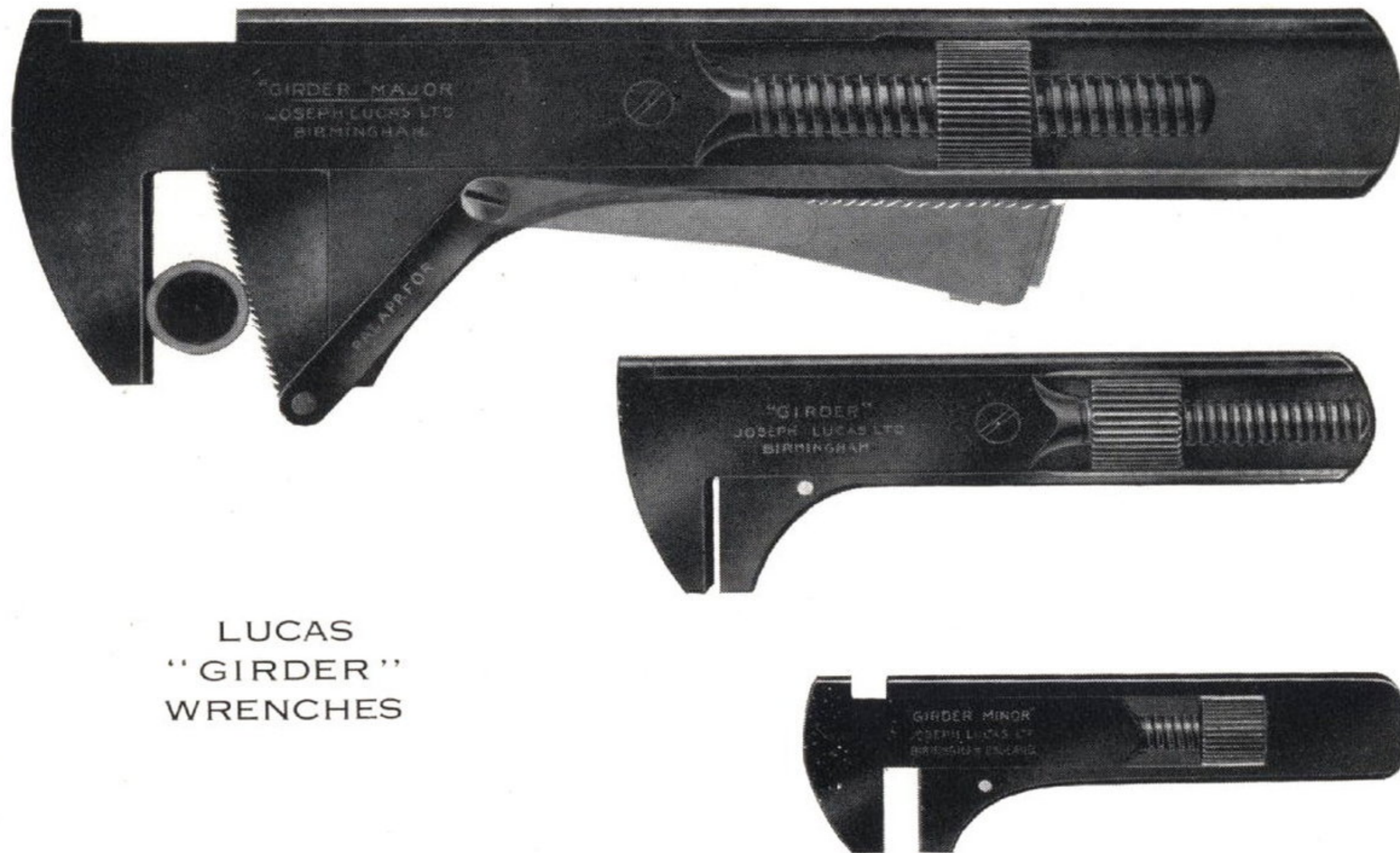
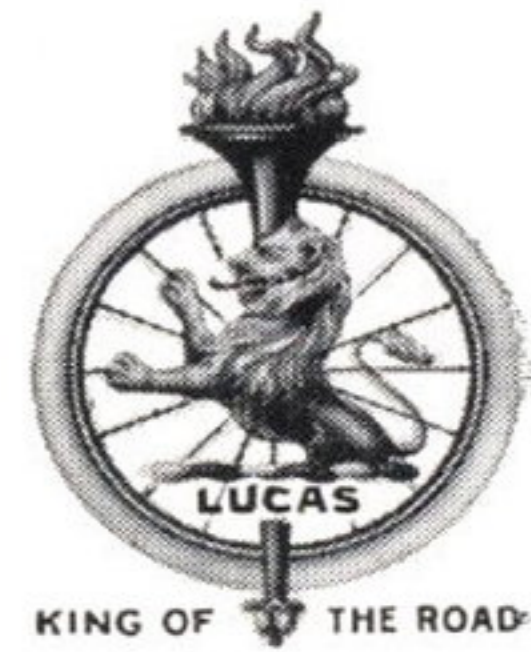

LUCAS
"GIRDER"
WRENCHES

LUCAS "FORCED-FEED" OILER

Our "**Forced-Feed**" Oiler is a necessary item in every motor-cyclist's outfit. It ensures the oil "getting there," whereas with the ordinary drip oiler one can never be sure whether the oil is dropping at all or running to waste. The specially designed thumb-operated pump will deliver just one or two drops or a little stream, and it forces the oil, under pressure, wherever it is required, even in the most awkward places.

No. 40 is an exceptionally neat pattern designed for use on heavy machines, cycle-cars, etc. It is nice to handle, of ample capacity, and as the Oiler is oval in shape it does not take up much space in the tool kit. It has a flat base, so will stand when not in use. A special retainer to hold the oiler tip is now fitted which prevents the latter becoming mislaid when the Oiler is being used.

No.	Capacity.	Length.	Width.	Height.	Finish.	CASH PRICE EACH
40	$\frac{1}{4}$ pint	8 $\frac{1}{4}$ in.	1 $\frac{1}{2}$ in.	4 $\frac{1}{4}$ in.	Polished Brass.. ..	7/6

A **Spring Clip** is provided to carry the No. 40 Oiler, which can be conveniently secured to the woodwork inside the side-car, or it may be screwed to the inside of the tool-box. It can be fixed horizontally or vertically, as required, and holds the Oiler firmly in position, preventing its being thrown about and becoming damaged.

No.	Finish.	CASH PRICE EACH
4	Clip for No. 40 Oiler Black	1/-

POSTAGE EXTRA.

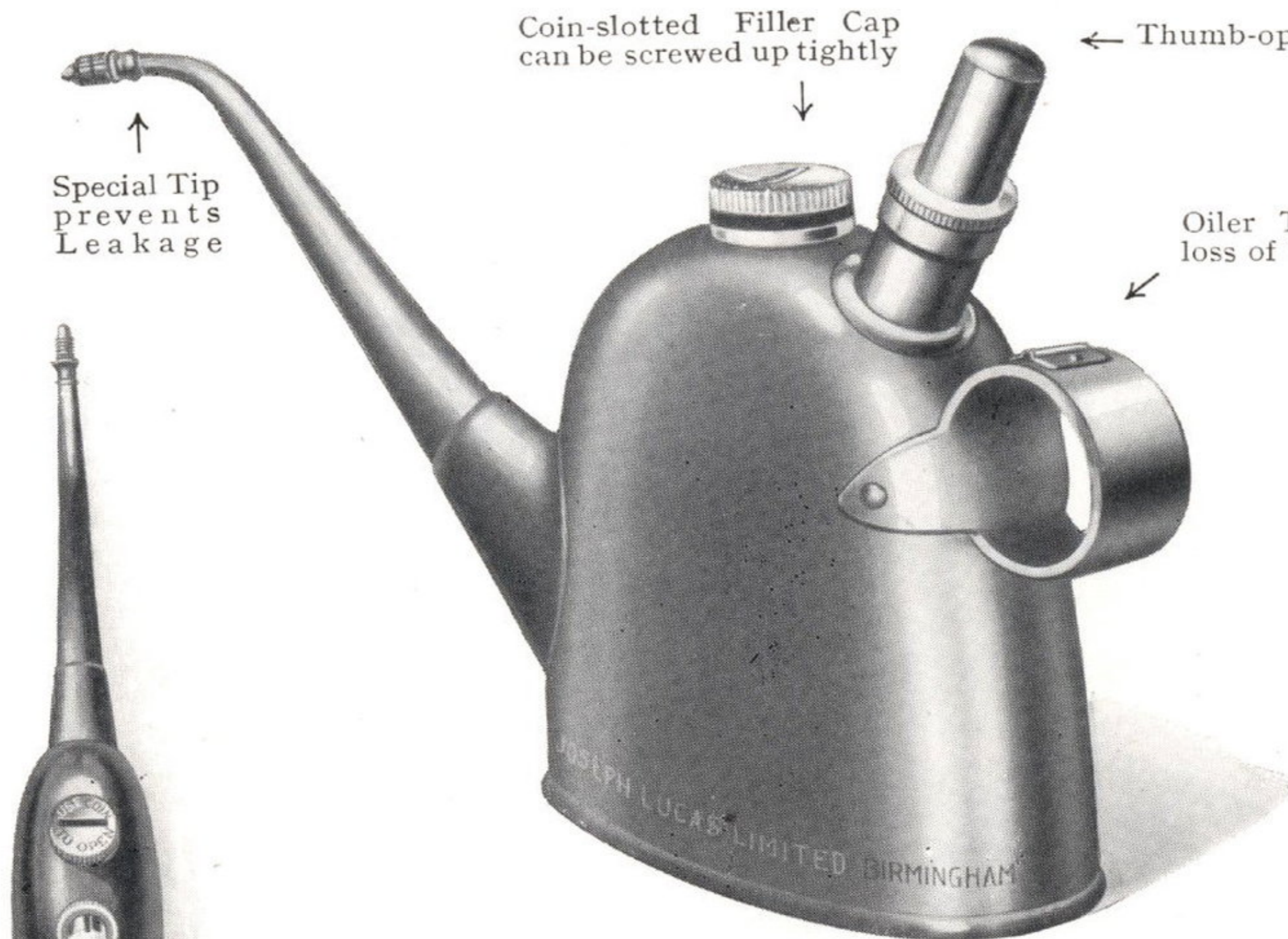

Coin-slotted Filler Cap
can be screwed up tightly

← Thumb-operated Pressure Pump

↑
Special Tip
prevents
Leakage

←
Oiler Tip Retainer prevents
loss of Tip when Oiler is in use

"FORCED-FEED" OILER
No. 40

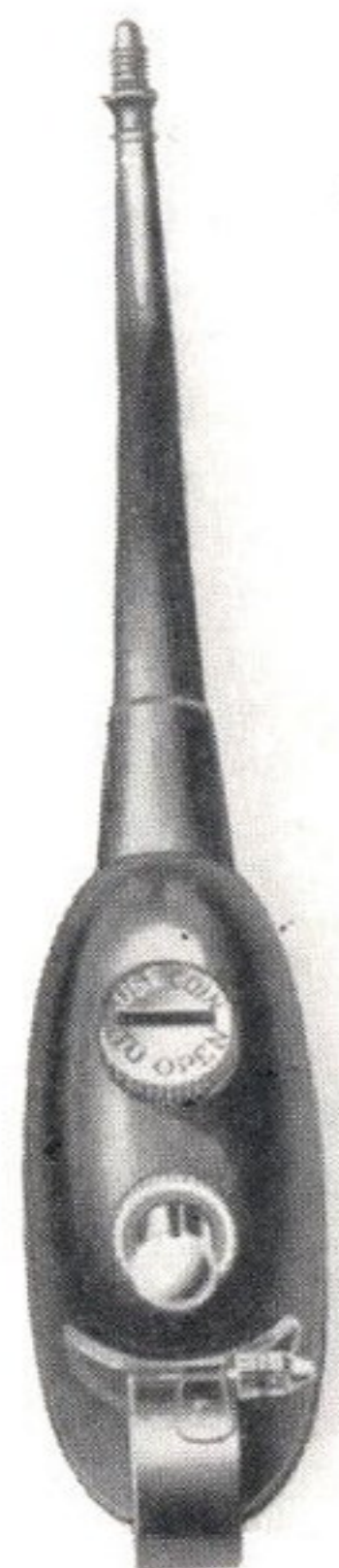

NO. 40
Plan View
showing
Flat Shape

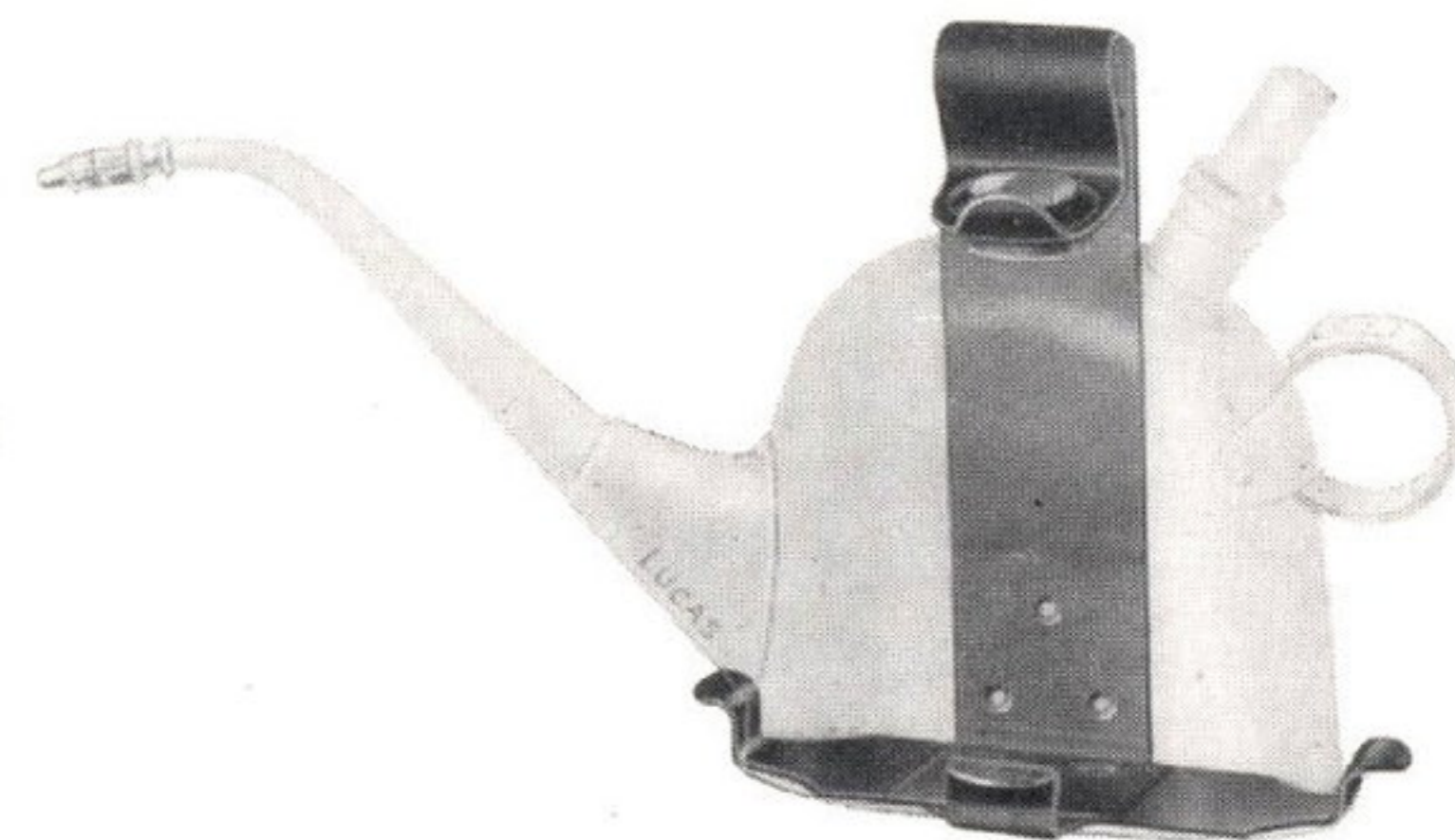

NO. 4 CLIP FOR
NO. 40 OILER

LUCAS

PATENT POCKET SCREWDRIVER

This Pocket Screwdriver is of the "propeller" type, and when not in use the blade is concealed in the barrel.

The toughened steel blade is hollow ground, so that it engages firmly in the slot of the screw and does not slip.

It has a quick-thread screw, and with a few turns of the barrel the blade is exposed for use.

The replacement of a blade is a very simple matter. Unscrew the milled cap at the head of the Screwdriver, and a few anti-clockwise turns of the barrel will enable the blade to be readily withdrawn.

This neat little tool is suitable for all light work, and is particularly convenient for carrying in the waistcoat pocket.

No.	Length (closed)	Finish.							CASH PRICE EACH
1	4 $\frac{3}{16}$ in.	Plated	2/-
		Spare Blades for this Screwdriver	..						9d. each.

POSTAGE EXTRA.

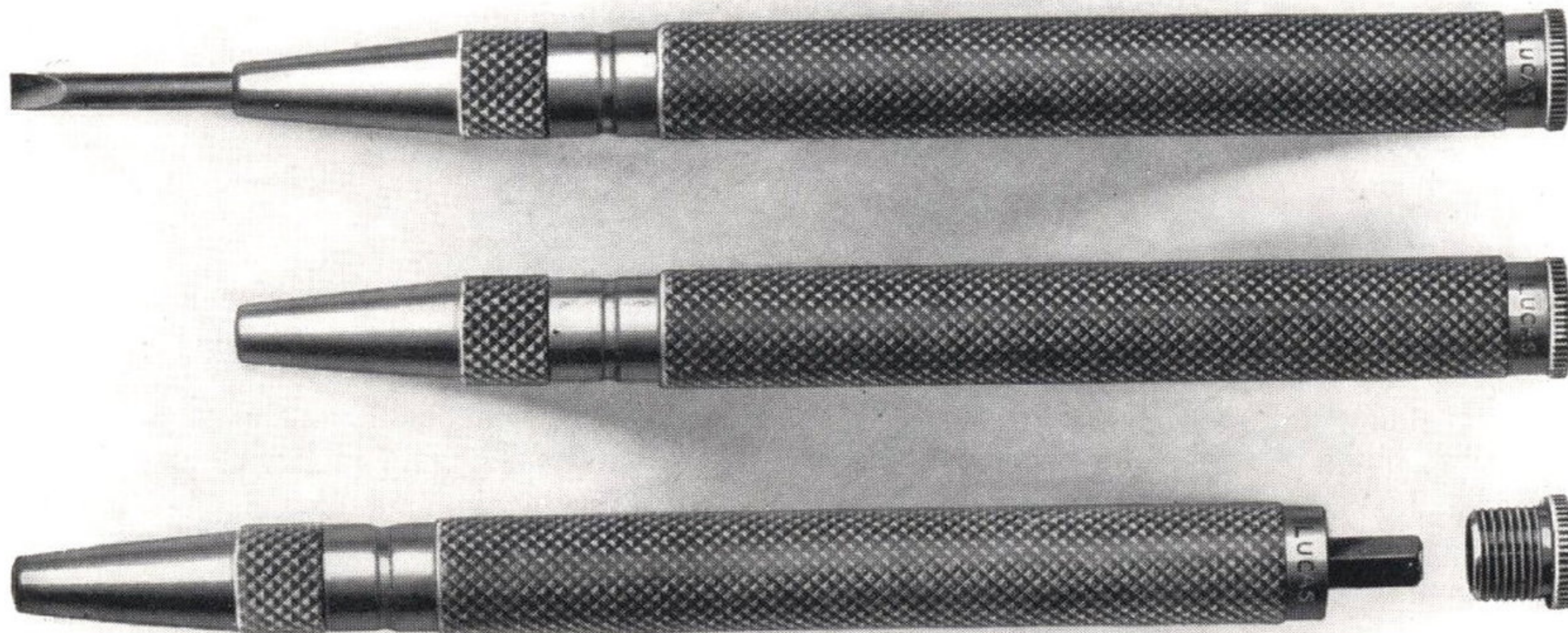

PATENT POCKET SCREWDRIVER

LUCAS ROUND PATTERN OILER No. 20

This Oiler is made of brass, and has a bent spout which facilitates oiling, even in awkward places.

The "popple" is designed to give quick recovery, and the filler-cap is coin-slotted for screwing up tightly. The oiler tip is fitted with a leather plug, which prevents leakage.

No.	Capacity.	Diameter.	Length.	Finish.	CASH PRICE EACH
20	$\frac{1}{8}$ pint	$3\frac{1}{4}$ in.	$8\frac{1}{2}$ in.	Nickel Plated	2/9

LUCAS PETROL SQUIRTS Nos. 2 AND 3

These Squirts are fitted with special end to spout, with fine bore and petrol-tight screw tip.

No.	Length.	Diameter.	Finish.	CASH PRICE EACH
2	5 in.	—	Nickel Plated	1/3
3	7 in.	$2\frac{5}{8}$ in.	Nickel Plated	2/-

All Oilers and Petrol Squirts are thoroughly tested, and will not leak.

POSTAGE EXTRA.



No. 20 OILER

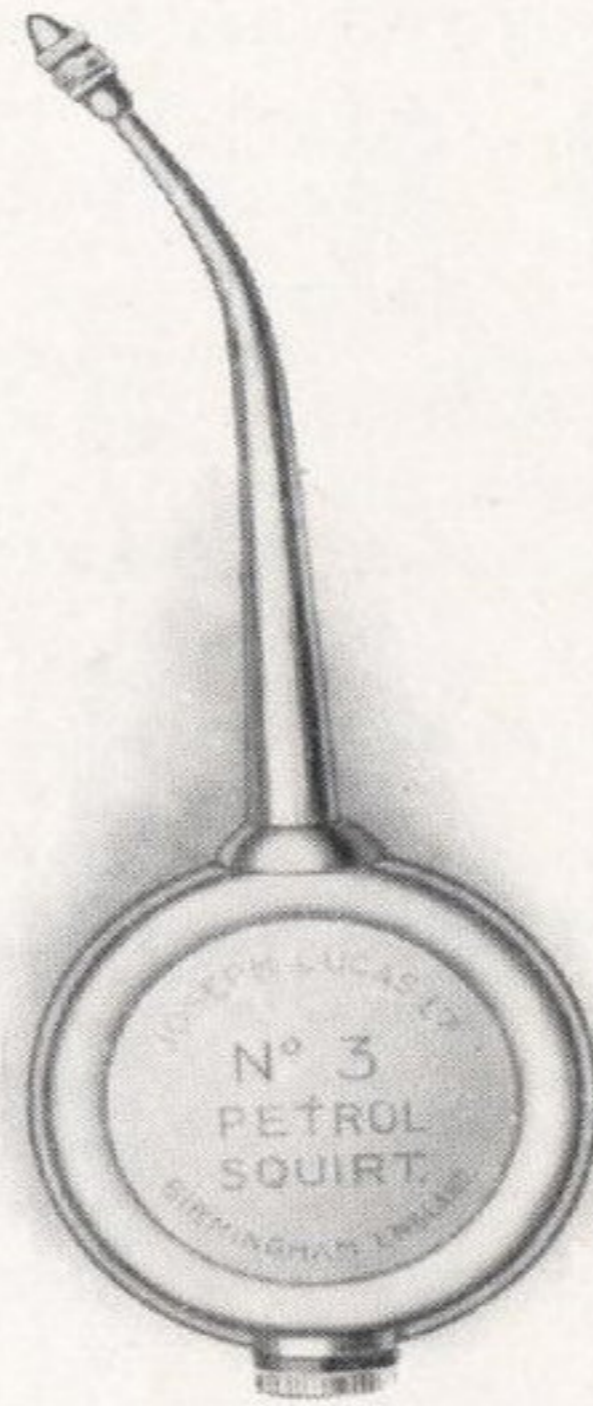

PETROL SQUIRTS

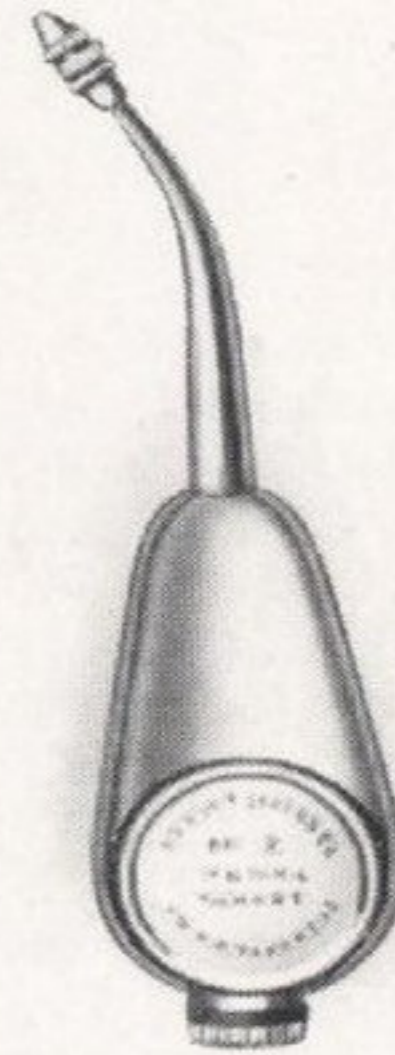

CASH PRICES FOR REPAIRS & PARTS

(MOTOR-CYCLEALITIES)

N.B.—All Repairs must bear a Label, INSIDE THE PACKAGE, giving sender's name and address, and should be despatched "Carriage Paid," to JOSEPH LUCAS LTD., GREAT HAMPTON STREET, BIRMINGHAM, except London District Repairs, which should be sent to our Acton Depot, Dordrecht Road, Acton Vale, W.3.

MOTOR-CYCLE LAMPS AND GENERATORS.

		PRICES			PRICES
Regulators—					
	Nos. 44, 54	6d. each	Water Screw—Nos. 31, 42, 44, 52, 54	4d. each
	Nos. 31, 42, 51, 52, 62	9d. ,,		Nos. 51, 62	8d. ,,
Burners—			Centre Screw—Nos. 31, 44, 54	8d. ,,
	No. 52, "Roni," for Nos. 341, 462, 472	2/1 ,,	Glass only—No. 472	2/- ,,
	No. 40, "Roni," for Nos. 342, 345, 442	1/4 ,,		Nos. 442, 462	1/4 ,,
	No. 30, "Roni," for No. 331	1/4 ,,		Nos. 341, 342, 345, 454	1/- ,,
	No. 53, "Roni," for No. 354	1/2 ,,		No. 331	8d. ,,
	No. 11 } for No. 350	5d. ,,		Nos. 350, 354	3d. ,,
	No. 372 }			No. 344 (Ruby)	6d. ,,
	No. 6, "Vika," for No. 344 (previous	6d. ,,	Wire for Glass	4d. ,,
	to 1922)	3d. ,,	Mangin Mirror—No. 472	13/6 ,,
	No. 306 for No. 344	3d. ,,		No. 462	10/6 ,,
Rubber Rings—				Nos. 341, 454	8/6 ,,
	Nos. 44, 54	2d. ,,		Mirror Reflector—No. 442	4/6 ,,
	Nos. 31, 42, 51, 52, 62	3d. ,,		Nos. 342, 345	3/- ,,
Carbide Containers—				Nos. 231, 331	2/- ,,
	Nos. 44, 54	1/- ,,		Reflector (Aluminium)—No. 354	6d. ,,
	Nos. 31, 42, 51, 52, 62	2/- ,,		No. 350	4d. ,,
Container Cage, No. 62	3/3 ,,		Front Door complete—No. 472	15/- ,,
Carbide Cover and Spring—				No. 462	10/6 ,,
	Nos. 44, 54	4d. ,,		No. 442	10/6 ,,
	Nos. 31, 42, 51, 52, 62	6d. ,,		Nos. 341, 342, 345, 454	6/- ,,
Carbide Plate and Tube—				No. 331	4/3 ,,
	Nos. 31, 51, 52, 62	9d. ,,		No. 354	1/9 ,,
Carbide Tube—Nos. 44, 54	1d. ,,		No. 350	1/- ,,
	Nos. 31, 42, 51, 52, 62	3d. ,,			

MOTOR-CYCLE HORNS.

Bulb with Socket for Nos. 32, 60 Horns	4/3 each	Reeds for No. 63 Horn	1/- each
" " " " Nos. 60P, 63 Horns	3/3 ,,	Handle-bar Clip, with Screws, for Nos. 32, 60	2/- ,,
Sockets for Nos. 32, 60 Horns	9d. ,,		Horns	2/- ,,
" " " " Nos. 60P, 63 Horns	6d. ,,	Handle-bar Clip, with Screws, for Nos. 60P,	1/2 ,,
Reeds for Nos. 32, 60, 60P Horns	1/6 ,,		63 Horns	1/2 ,,

Please state Type Number of Lamp or Horn when ordering Spares.

LUCAS

ELECTRICAL EQUIPMENT

FOR MOTOR-CYCLES

1928

The words "LUCAS," "KING OF THE ROAD," "CYCLEALITIES," "MOTOR-CYCLEALITIES," "MOTORALITIES," and "MAGDYNO" are Registered Trade Marks for Goods of Lucas manufacture.

DESIGNED AND MANUFACTURED BY

JOSEPH LUCAS LIMITED

HEAD OFFICES AND WORKS:

GREAT KING STREET, BIRMINGHAM

TELEGRAMS AND CABLES: "LUCAS, BIRMINGHAM." TELEPHONE: NORTHERN 2201 (10 LINES)

CODES USED: A B C (5TH AND 6TH EDITIONS) AND BENTLEYS

SERVICE DEPÔTS:

BELFAST—3/5, Calvin Street, Mountpottinger

Telegrams— — — "SERVDEP, BELFAST."

Telephone— — — — BELFAST 7017.

BIRMINGHAM—Great Hampton Street

Telegrams— — — "LUCAS, BIRMINGHAM."

Telephone— — — NORTHERN 2201 (10 lines).

BRISTOL—25, Temple Street

Telegrams— — — "KINGLY, BRISTOL."

Telephone— — — BRISTOL 8400 (3 lines).

CARDIFF (Opening shortly)—Penarth Road

Telegrams— — —

Telephone— — —

COVENTRY—Priory Street

Telegrams— — — "LUCAS, COVENTRY."

Telephone— — — COVENTRY 3068 & 3841.

DUBLIN—41, Middle Abbey Street

Telegrams— — — "AUTOLITE, DUBLIN."

Telephone— — — — DUBLIN 653.

NEWCASTLE-ON-TYNE—64-66, St. Mary's Place

Telegrams — — — "MOTOLITE, NEWCASTLE-ON-TYNE."

Telephone — — — — — CENTRAL 3571 (3 lines).

GLASGOW—227/229, St. George's Road

Telegrams— — — — "LUCAS, GLASGOW".

Telephone— — — — DOUGLAS 3075 (3 lines).

LEEDS—64, Roseville Road

Telegrams— — — — "LUSERDEP, LEEDS."

Telephone— — — — LEEDS 28591 (5 lines).

LONDON—Dordrecht Road, Acton Vale, W.3.

Telegrams— — — — "DYNOMAGNA, ACT. LONDON."

Telephone— — — — CHISWICK 3801 (18 lines).

LONDON—759, High Road, Leyton, E.10

Telegrams— — — — "LUSERDEP, WALT, LONDON."

Telephone— — — — WALTHAMSTOW 2161 (2 lines).

LONDON—155, Merton Road, Wandsworth, S.W.18

Telegrams— — — — "LUSERV, WANDS, LONDON."

Telephone— — — — PUTNEY 5131 (4 lines) & 5501.

MANCHESTER—Talbot Road, Stretford

Telegrams— — — — "LUCAS, STRETFORD."

Telephone— — — — TRAFFORD PARK 1410 (3 lines).

All Previous Catalogs Cancelled.

October, 1927.

IN ADDITION THERE ARE BATTERY SERVICE AGENTS IN MOST CENTRES.

LUCAS "MAGDYNO" (REG.) (LIGHTING & IGNITION)

The Lucas "Magdyno" (Combined Lighting and Ignition) Set enables the Motor-Cyclist to have the advantages of car lighting. With the "Magdyno," only a turn of the switch is necessary to give a brilliant and even flood of light over the whole width of the road for a tremendous distance ahead, besides providing a healthy spark for ignition at all speeds. Most well-known makers now catalog their machines with Lucas Electrical Equipment as standard at an inclusive price, or as an alternative.

Lucas Equipment is subjected to constant testing and research, and its continued and progressive advance in detail of design is proved by its popularity, and the fact that it is fitted to-day by the thousand as standard, or when specified. A few of the improvements incorporated in 1928 Models are: new cut-out of robust design, stronger gear drive, and waterproof terminals. The magneto section carries the Lucas Magneto Guarantee, and has special features developed by racing performance.

The "Magdyno" is a full-size machine (30 watts) and, as the name suggests, consists of two units: a magneto for ignition and a dynamo for charging the battery, both units being neatly housed within an aluminium body. Power is transmitted to the dynamo (the upper unit) by gears driven from the magneto spindle. The machine is thus equivalent to a somewhat taller magneto, the size as regards bolt hole centres and height of spindle remaining the same as the ordinary standard magneto; the same chain and gear drive for the latter sufficing for the "Magdyno," enabling it to be fitted without the provision of an extra drive.

As the magneto is no longer required, the full list price is allowed by us for new magnetos (see page 58).

To owners of motor-cycles already in use we are willing to make the best possible allowance for the old magneto, according to its age. Full particulars on application.

Specifications of the complete "Magdyno" Sets, for Solo or Combination Machines, are given below, and the various component parts are illustrated and described on the pages of this Catalog detailed below.

Length, $7\frac{7}{8}$ in.

Width, $4\frac{1}{4}$ in.

Height, $6\frac{3}{8}$ in.

Weight, 13 lb.

"MAGDYNO" SOLO SET comprises:—

"Magdyno" (For Single-Cylinder Engines).

Projector No. SS47 (with Switch and Ammeter), described and illustrated on pages 42 and 43.

Tail Lamp No. MT110, described and illustrated on pages 46 and 47.

Battery No. LJW7E (Lucas "Milam"), described and illustrated on pages 48 and 49.

Set of Cables, etc.

Price of Solo Set complete, in Ebony Black finish	£10 17 6
Extra for Two-Cylinder "Magdyno"	7 6
Extra for Lucas Patent Dipping Reflector Equipment for Head Lamp , described and illustrated on pages 42-43	1 0 0

"MAGDYNO" COMBINATION SET comprises:—

As above, but with:—

Side-Car Lamp No. R330S, described and illustrated on pages 46 and 47.

Price of Side-Car Set complete, in Ebony Black finish	£11 7 6
Extra for Two-Cylinder "Magdyno"	7 6
Extra for Lucas Patent Dipping Reflector Equipment for Head Lamp , described and illustrated on pages 42-43	1 0 0

Full list price allowed for new magnetos (see page 58). Allowance for used magnetos according to age.

Write for full particulars.

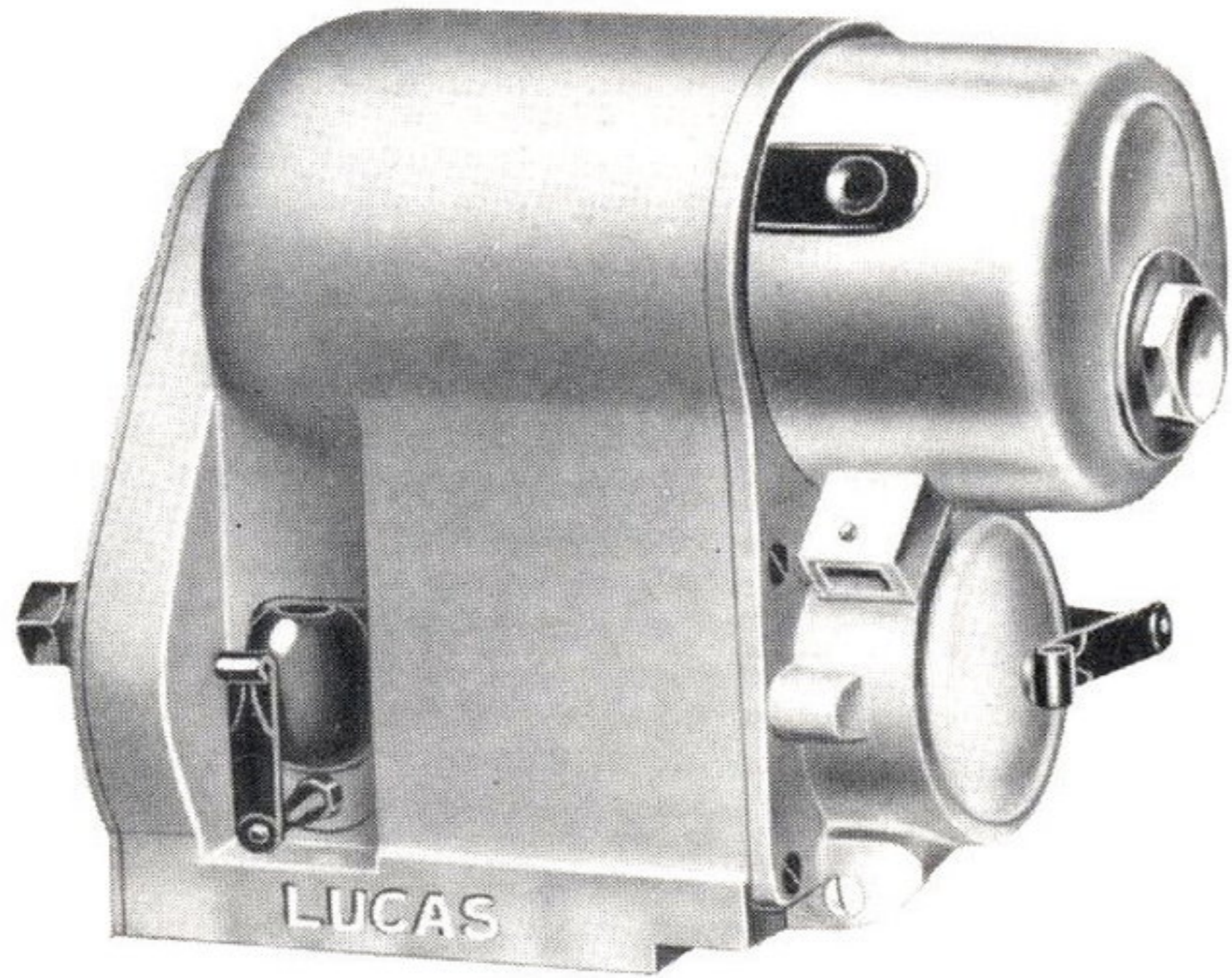
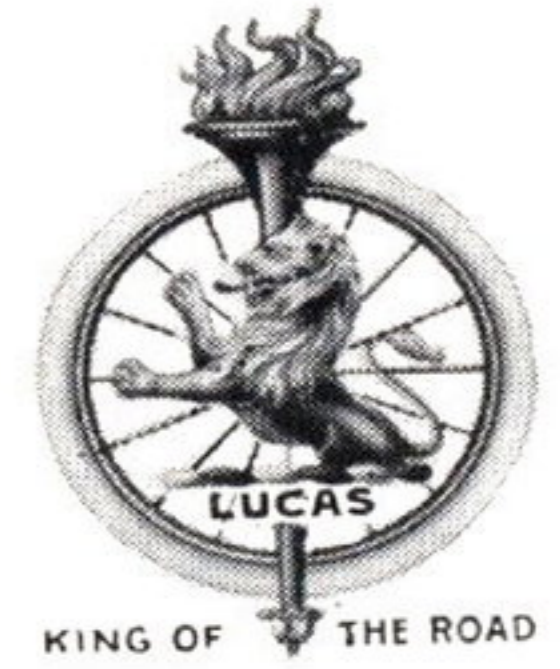

LUCAS "MAGDYNO" (REG.)

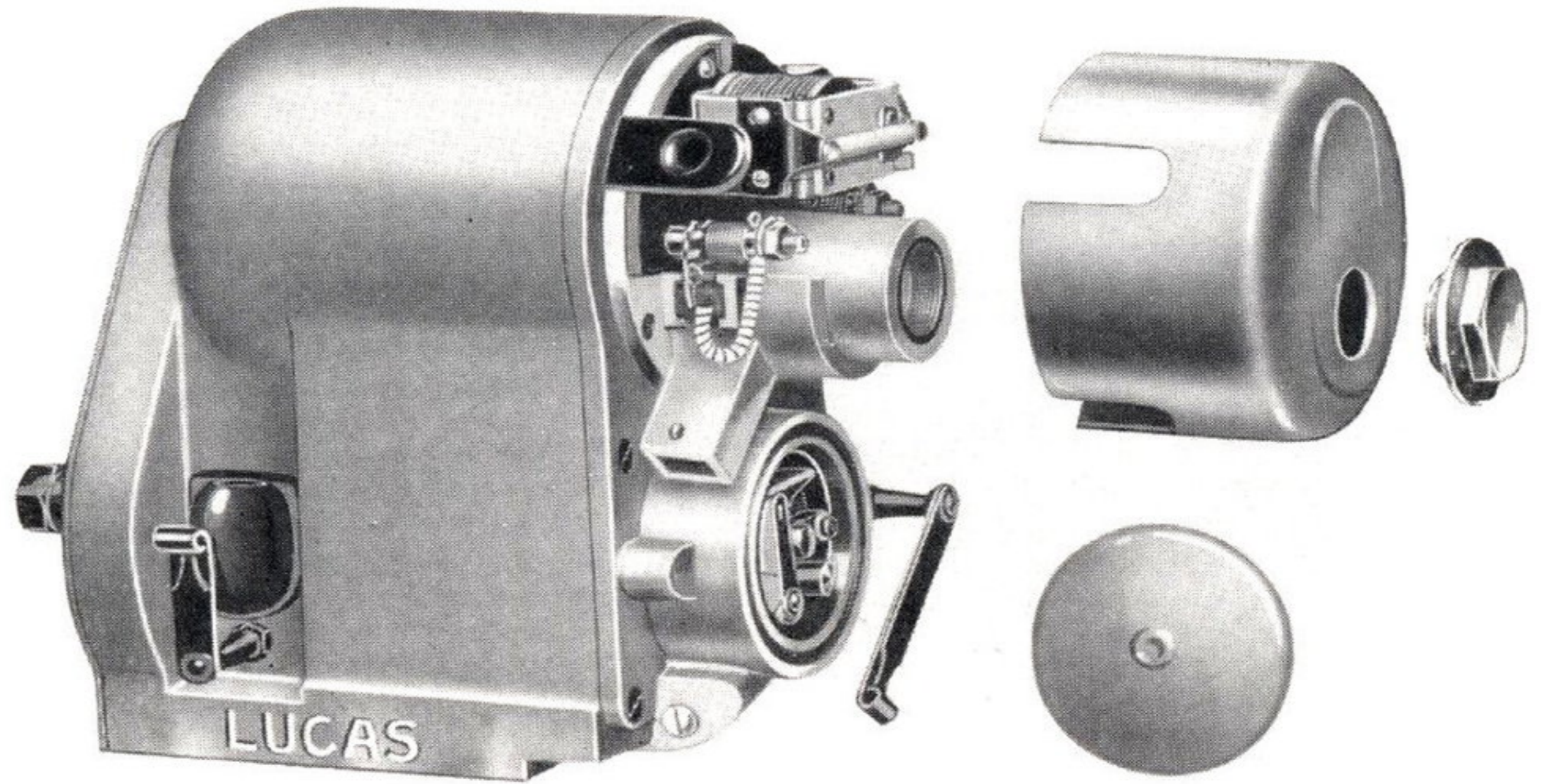

VIEW OF "MAGDYNO" WITH COMMUTATOR AND CONTACT BREAKER END COVERS REMOVED

LUCAS "KING ^{OF} THE ROAD"

MOTOR-CYCLE ELECTRIC PROJECTOR

AND WITH THE NEW LUCAS PATENT DIPPING REFLECTOR

No. SS47 Motor-Cycle Projector is a new large model for 1928. It is bold and pleasing in outline, and is used in "MD" "Magdyno" Sets.

It has a 6 in. diameter reflector, is fitted with the Lucas "Difusa" glass, which projects a beam eliminating all streaks of light, and has a high-power gas-filled bulb, which gives a powerful, even light which floods the road over its whole width for a long distance ahead.

Other special features are that the controlling switch is mounted on the top of the lamp and is easily operated even when the Projector is set in a low position. Also the ammeter is incorporated in the body of the lamp so that it is readily visible to the rider.

Provision is made to allow alternative of a full driving light for the open road and a reduced light for town use.

The front rim and reflector are easily detached for the purpose of bulb replacement, wiring, etc.

The Girder Brackets are strong and rigid, and the new ball socket mounting allows the lamps and brackets to be correctly set without strain to either.

The above Projector can now be supplied with the new **Lucas Patent Dipping Reflector**.

The whole principle is entirely new, fully covered by Lucas patents, and is already acknowledged as the simplest and most efficient anti-dazzle device, being standardized by many of the leading Car and Motor-Cycle Manufacturers.

Control is by movement of one small knob on a neat air cylinder mounted on the handlebars. This cylinder is connected by tubing to a similar but smaller cylinder in the lamp, a piston in this lamp cylinder being coupled to the back of the removable reflector.

When the knob of the operating cylinder is pulled out, air is sucked out of the lamp cylinder, causing the piston rod to move and pull the reflector into the dipped position. To return to normal position, the control knob is simply pushed in again.

The system does not depend on maintenance of air pressure or vacuum to keep the reflector in either position—the reflector is maintained rigidly by a spring device. The lighting power is not diminished in the least by these dipping reflectors.

Front, 7 in.

Aperture, 6 in.

Weight, 2 $\frac{3}{4}$ lb.

No.	Finish.	CASH PRICE
		EACH
SS47	Ebony Black, complete with Girder Brackets, Switch and Ammeter	£2 17 6
SS47D	As above, complete with Dipping Reflector, Operating Cylinder and Tubing	3 17 6

POSTAGE EXTRA.



OPERATING CYLINDER
WITH HANDLE-BAR CLIP

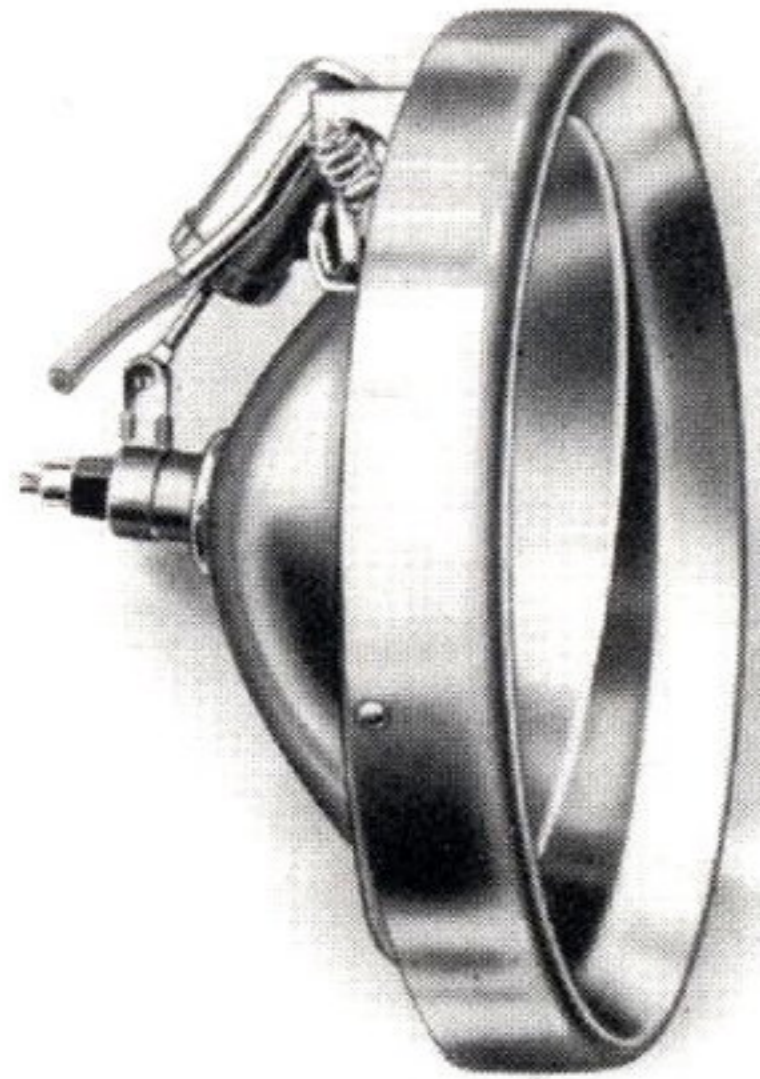

REFLECTOR DIPPED—
ELIMINATING DAZZLE

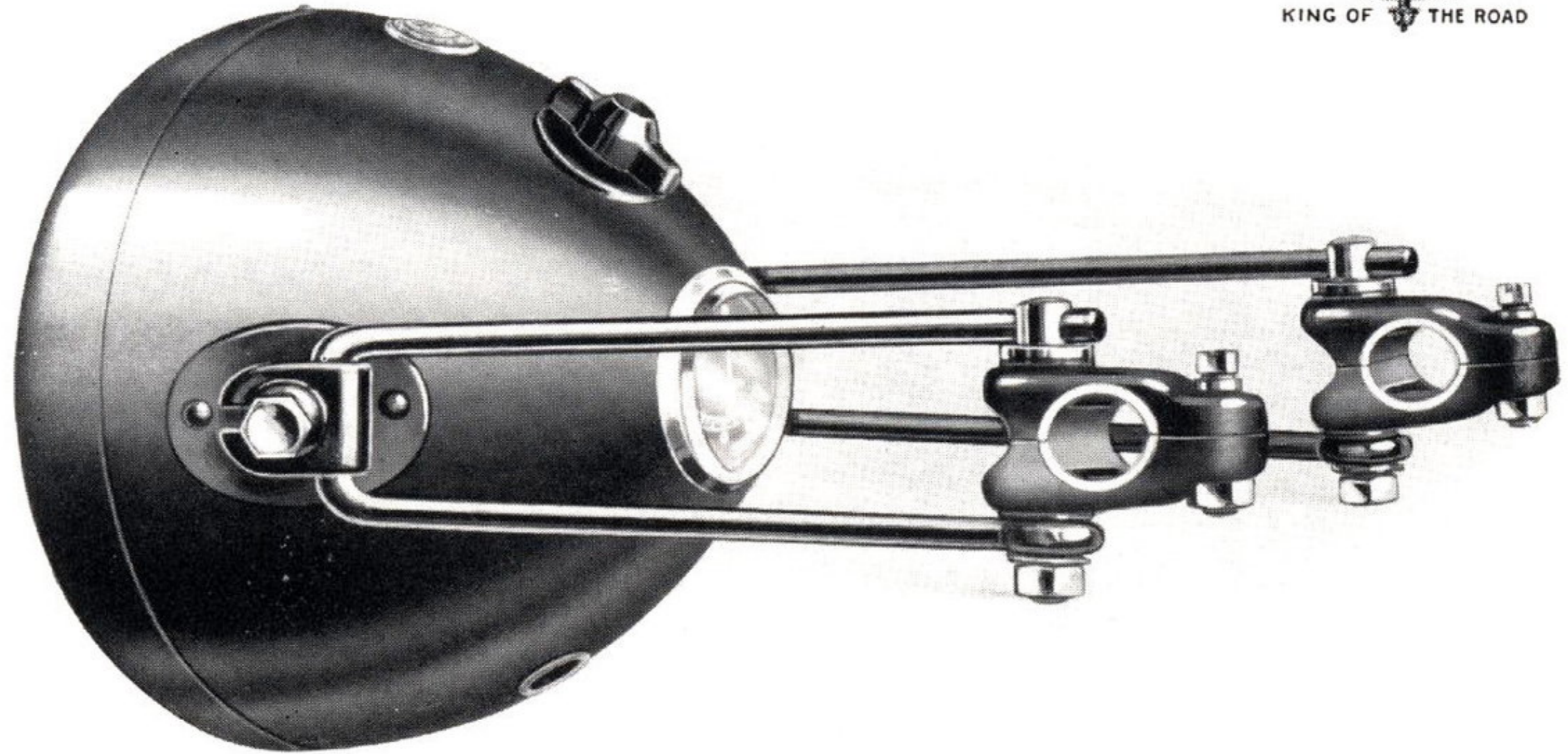

No. SS47
WITH SWITCH, AMMETER
AND GIRDER BRACKETS

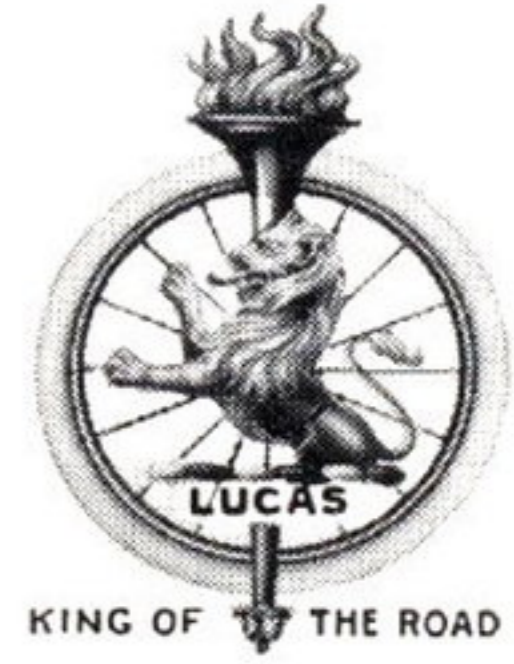

LUCAS

BATTERY LIGHTING EQUIPMENT

For Motor-Cycles on which it is impossible to fit one of our "Magdyno" Sets, or where it is undesirable to do so on account of cost, a Battery Lighting Set can be supplied. There is no difficulty whatever in fitting this equipment to any ordinary Motor-Cycle. When a Battery Set is used, ready access to charging facilities is, of course, a necessity.

The Set for Solo Machine comprises :—

Battery No. LJW7E, described on page 48.
Head Lamp No. SS30M (with Switch and Girder Brackets).
Tail Lamp No. MT110, described on page 46.
Set of Cables.

Price of Solo Set complete, in Ebony Black finish £2 15 0

The Set for Combination Machine comprises :—

As above, but with :—
Battery No. LK7E, of larger capacity, described on page 48.
Side-Car Lamp No. R330S, described on page 46.

Price of Side-Car Set complete, in Ebony Black finish £3 17 6

CARRIAGE FORWARD.

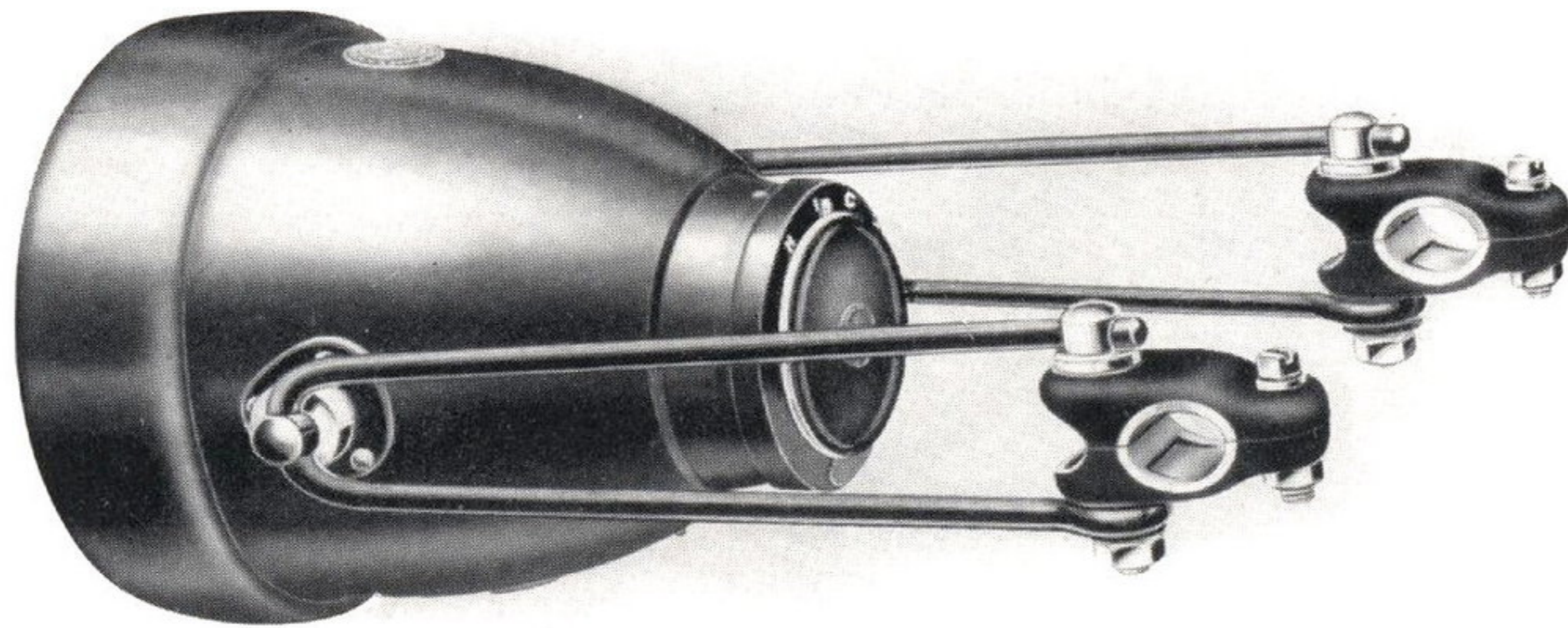

HEAD LAMP No. SS30M
(WITH SWITCH AND GIRDER BRACKETS)

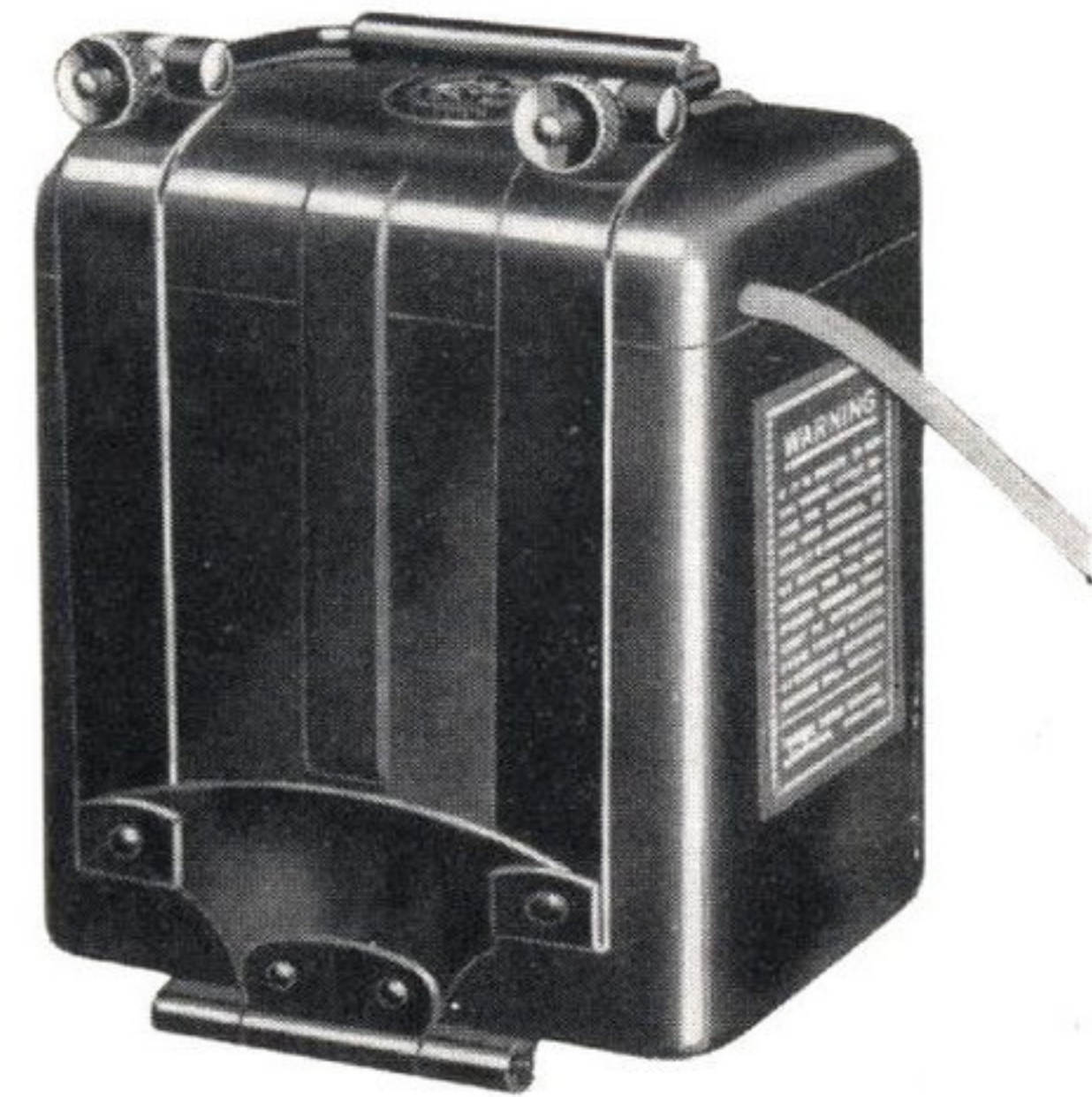

BATTERY No. LJW7E
WITH SOLO FITTINGS



SIDE-CAR LAMP
No. R330S



TAIL LAMP
No. MT110

LUCAS "KING ^{OF} THE ROAD"

ELECTRIC LAMPS FOR MOTOR-CYCLES

SIDE-CAR LAMPS Nos. R440S and R330S.

No. **R440S** is fitted with a **Silvered Reflector**, and has our **patented universally adjustable mounting** which enables the beam to be set to the best advantage on the road. It is of the concealed cable type and the front of the lamp is attached by a bayonet fixing, and is removed by pressing and turning to the left (looking at the front of the lamp). To assist in focussing a new bulb, notches, allowing for three alternative positions, are provided in the bulb holder.

No. **R330S** is a similar Side-Car Lamp to R440S, but smaller.

No.	Front.	Aperture.	Weight.	Finish.	CASH PRICE EACH
R440S	4½ in.	3⅝ in.	1 lb.	Ebony Black	19/-
R330S	3¾ in.	2⅞ in.	10 oz.	Ebony Black	12/6

TAIL LAMP No. MT110.

A lamp which embodies many new features. The bulb holder is mounted on a rubber diaphragm (see illustration) which absorbs vibration, thereby lengthening the life of the bulb filament. A hole is cut into the rear number plate to take the front of the lamp, which is secured by three rivets or screws through flange to number plate. The rear portion of the lamp is engaged by a bayonet joint which is locked by a half turn to the right. It is now fitted with a metal reflector which gives a much improved white light.

A red light is shown to the rear and a white side light illuminates the number plate, so that the lamp is suitable for Combinations of all weights.

No.	Finish.	CASH PRICE EACH
MT110 With 1⅛ in. Red Glass.	Ebony Black	8/6

POSTAGE EXTRA.

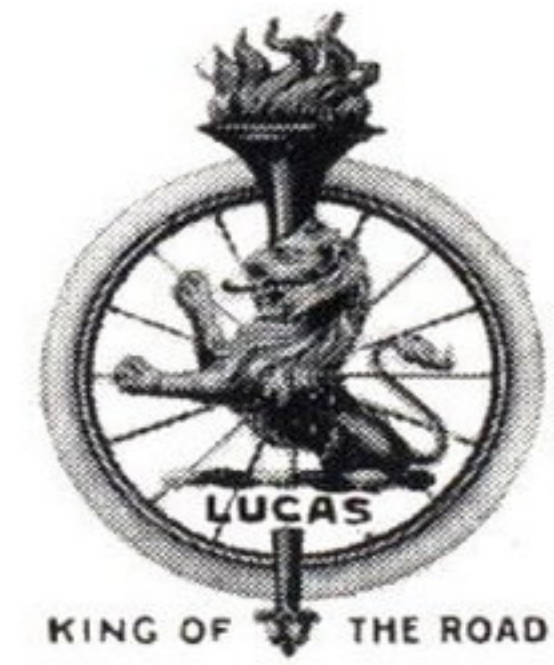

SIDE-CAR LAMPS Nos. R440S AND R330S

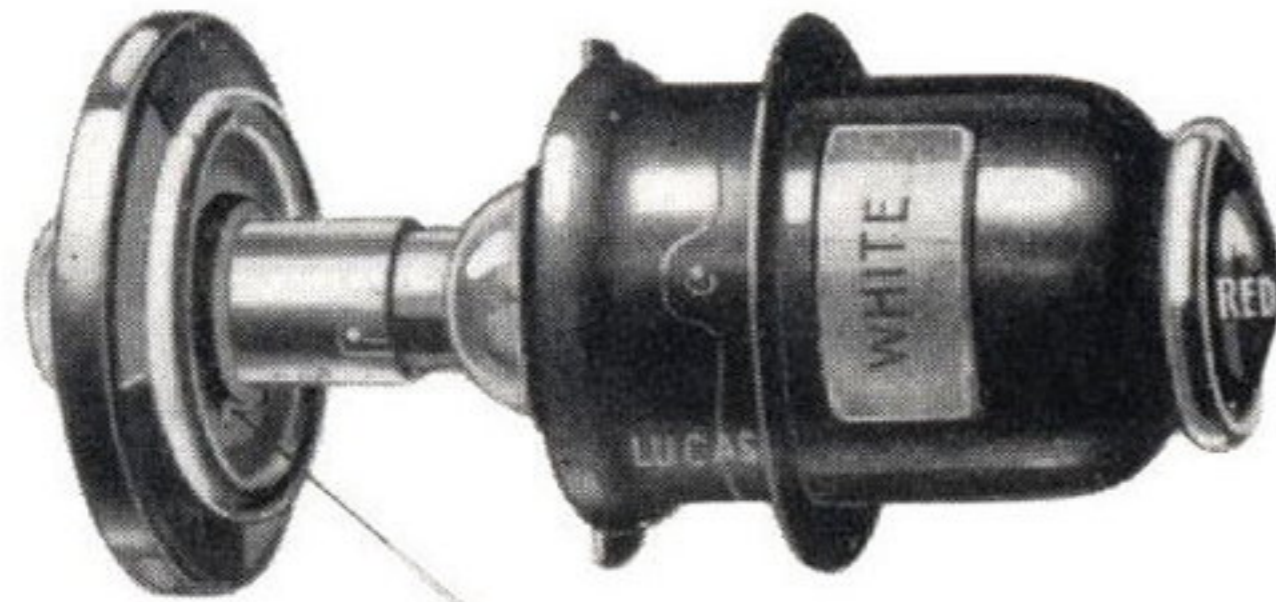

Rubber Diaphragm

TAIL LAMP No. MT110
FRONT DETACHED



TAIL LAMP No. MT110

LUCAS MOTOR-CYCLE BATTERIES

Lucas Motor-Cycle Batteries are symmetrical and neat, and embody the latest practice in battery design. They are manufactured throughout at the Lucas Battery Works, under the best conditions and with the latest and most improved plant.

Our Moulded "Milam" Batteries are stronger than the usual celluloid type; they are leak-proof, and practically immune from the risk of fire.

A special characteristic of Lucas Batteries is their low voltage drop on discharge. Our separators give the necessary rigidity to the section and ensure free diffusion of the electrolyte and low internal resistance. The terminals are robust, and are made of a non-corrosive alloy. The Batteries are entirely self-contained, making a separate case quite unnecessary.

The unique construction of the vents allows the free escape of gas at reduced pressure without carrying away the acid solution or permitting the ingress of moisture or dirt to the cell.

BATTERY No. LO5E ("Milam").

Type	Voltage.	Amp. hours.	Over-all Dimensions.						CASH PRICE EACH
LO5E	6	9	$6\frac{1}{8} \times 3 \times 7\frac{3}{8}$	Battery only	£1 5 0
LO5E	6	9		With Solo Fittings	1 10 0

BATTERY No. LH5E ("Milam").

LH5E	6	12	$5\frac{1}{4} \times 5\frac{1}{16} \times 5\frac{5}{16}$ in.	Battery only	£1 7 6
LH5E	6	12		With Solo Fittings	1 13 6
LH5E	6	12		With Side-Car Fittings	1 10 0

BATTERY No. LJW7E ("Milam").

LJW7E	6	12	$4\frac{13}{16} \times 3\frac{5}{8} \times 5\frac{5}{8}$ in.	Battery only	£1 5 0
LJW7E	6	12		With Solo or Side-Car Fittings	1 10 0

BATTERY No. LK7E (in Moulded Ebonite).

LK7E	6	21	$7\frac{1}{4} \times 4\frac{3}{4} \times 5$ in.	Without Tin Case	£2 2 0
LK7E	6	21	$10 \times 5 \times 5\frac{1}{2}$ in.	In Tin Case	2 12 0

POSTAGE EXTRA.



KING OF THE ROAD

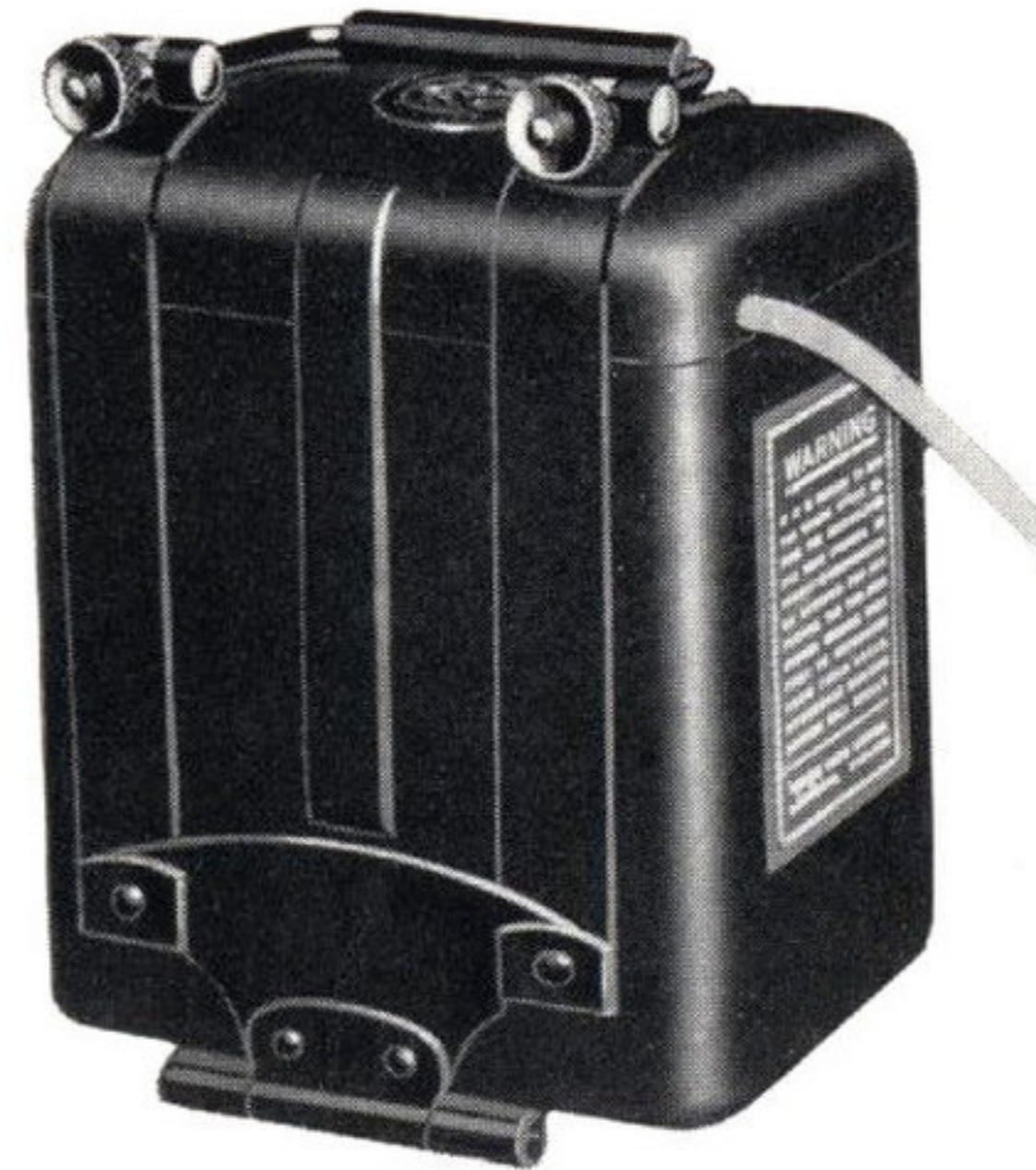

BATTERY
No. LJW7E
WITH
FITTINGS



BATTERY No. LO5E
WITH
SOLO FITTINGS

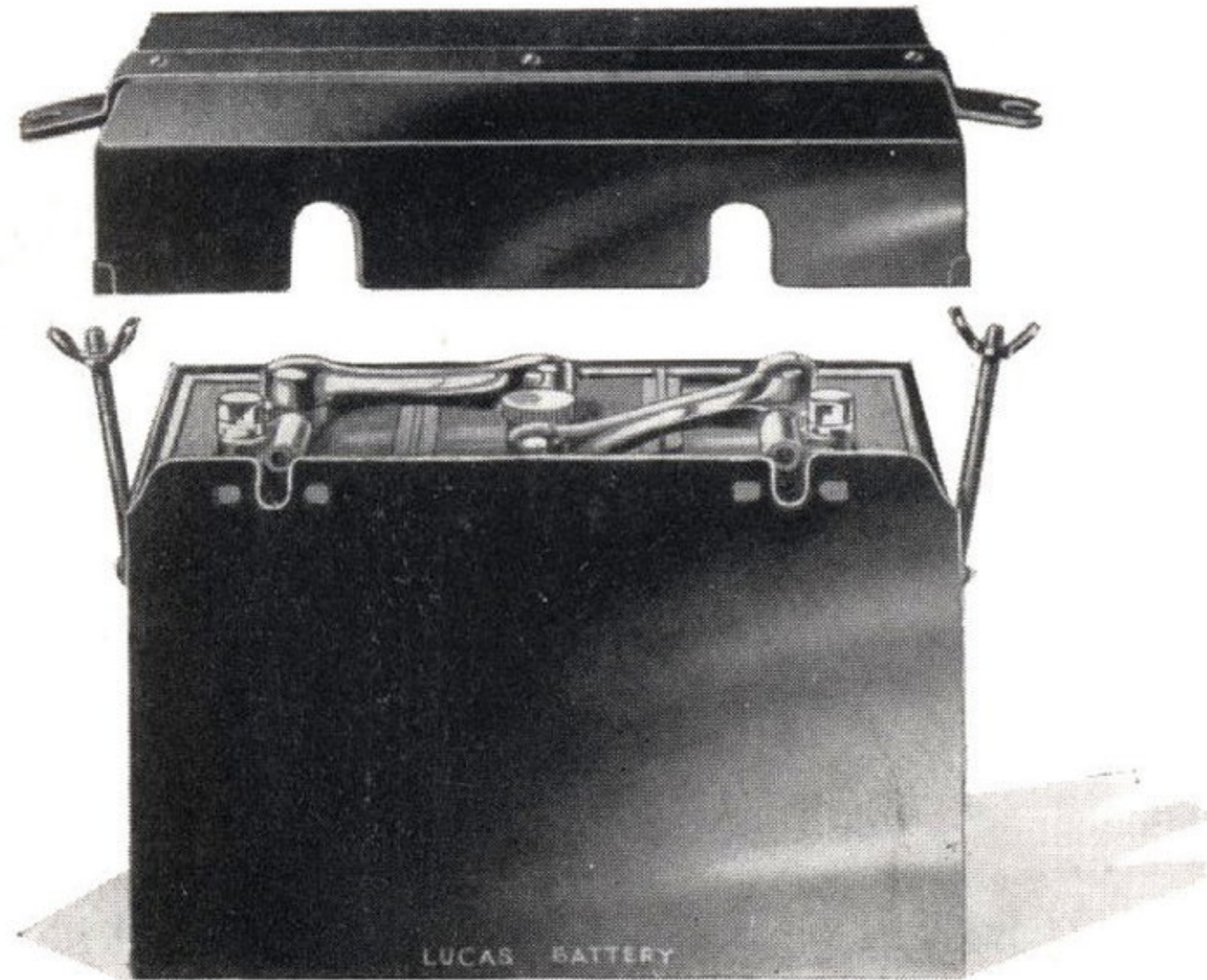

BATTERY No. LK7E
IN TIN CASE

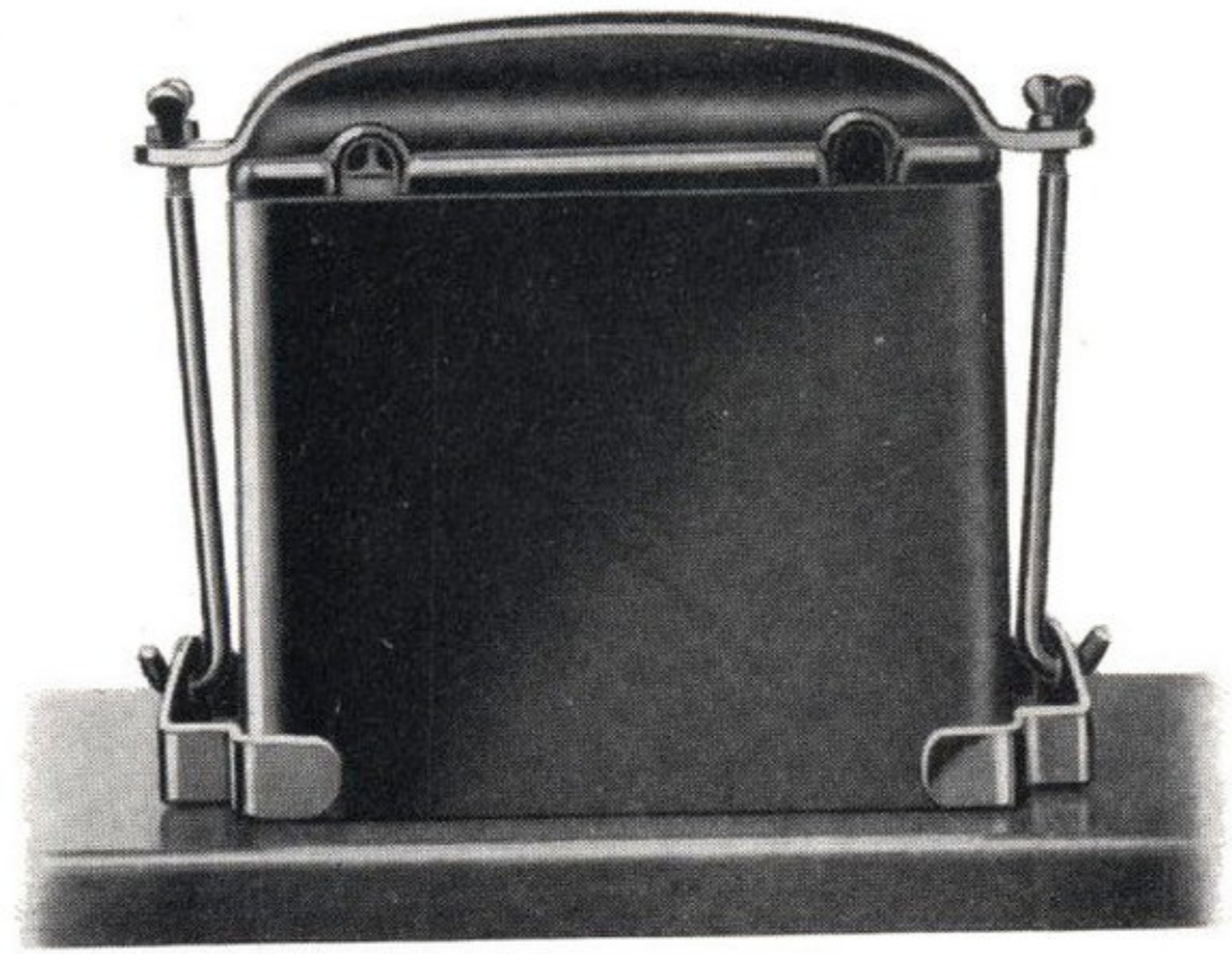

BATTERY No. LH5E
WITH SIDE-CAR FITTINGS

LUCAS "KING ^{OF} THE ROAD" ELECTRIC HORN

No. 3

EMBODYING MANY PATENTED FEATURES.

The Lucas Electric Horn should form part of the equipment of every Motor-Cycle fitted with a "Magdyno" Lighting Set. It is provided with a clip for the handle-bar, and the Horn Push should be fixed on the bar near the grips, so that the rider may sound the Horn without removing his hand from the brake or other lever he may be controlling.

This Horn gives a powerful, penetrative note, and its effectiveness and long distance carrying power have been thoroughly tested and are indisputable.

The final result has only been achieved after continuous scientific investigation in the laboratory combined with careful testing on the road. Another striking difference from ordinary horns is its durability: it can be operated for very long periods without attention of any kind, and is capable of withstanding the variation in voltage experienced with different Battery conditions, without affecting the purity of its note, a common fault with ordinary horns. Special provision has been made to eliminate sparking at the contact points.

No.	Finish.	CASH PRICE EACH
3	Ebony Black, with Horn Push, without Cable	17/6

6-volt (4-volt Horns can be supplied if required).

When ordering, state voltage required.

Horn Push only	2/6
-------------------------------	------------

Standard 5 mm. Black Ignition Cable for the above Horn, 6d. per yard.

POSTAGE EXTRA.

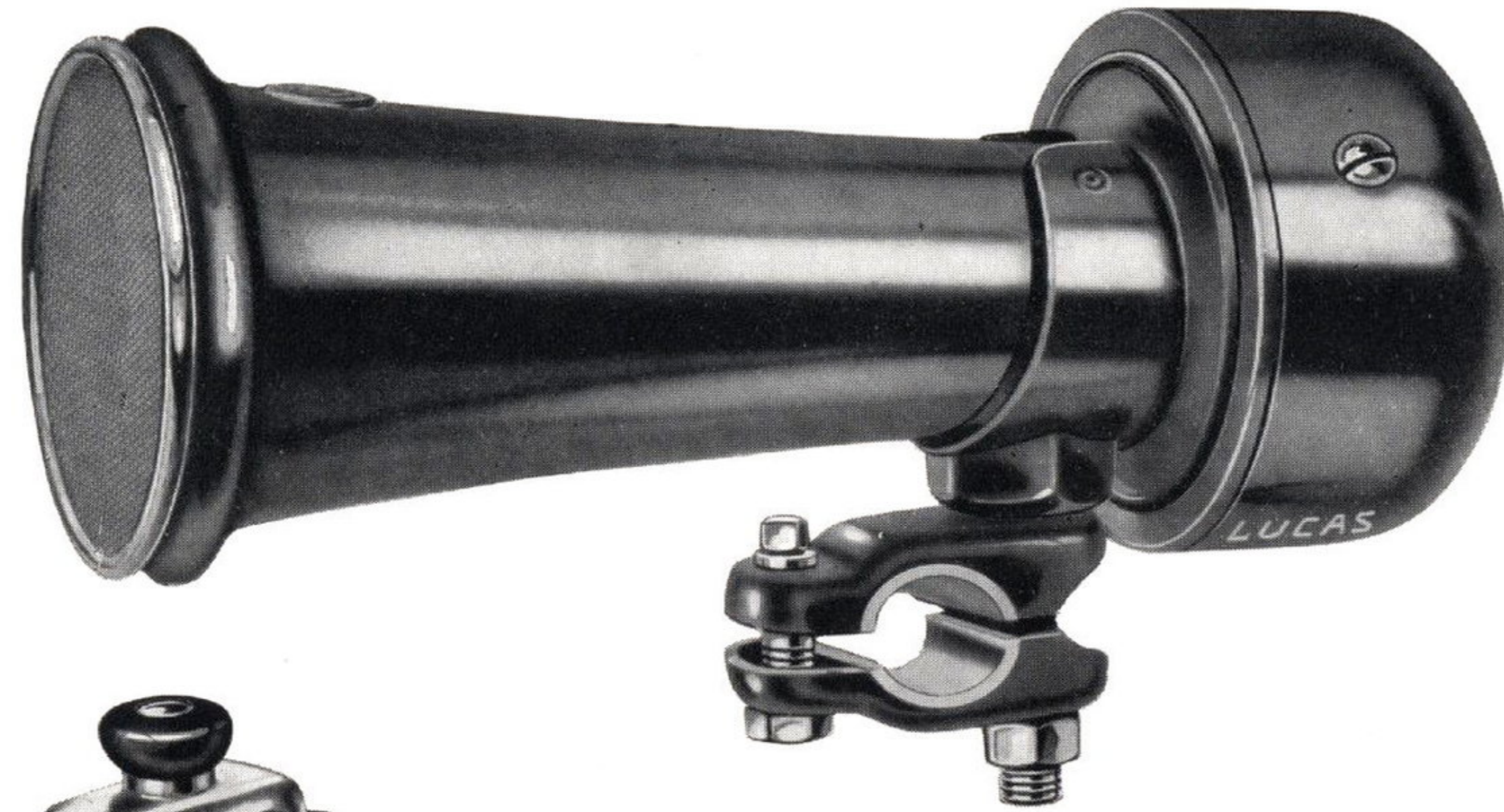

ELECTRIC HORN No. 3



HORN PUSH

LUCAS FESTOON AND DASH LAMPS

The **Lucas Festoon Lamps** are very useful for illuminating the dash or for lighting the interior of enclosed side-cars or taxi side-cars. These lamps occupy only a small space, and therefore when fitted as roof lamps readily permit the folding back of the hood. In each type the cylindrical body can be rotated to direct the light where required.

Type D10 does not need a separate switch, as turning the lamp body until the glass faces the base of lamp automatically switches the light off. The body is held in position by a spring plunger, and can be instantly removed for bulb replacement.

Type D5 has an "on" and "off" switch incorporated in the lamp. Its cylindrical body is hinged to the left-hand supporting post, and is held in position on the other side by a spring "click" locking arrangement. By swinging the body on its hinge the window portion of the lamp can be detached and the bulb replaced if required; this also allows the interior of the side-car to be lit direct from the bulb.

TYPE D10 FESTOON LAMP.

Dimensions: $5\frac{1}{2} \times 1\frac{3}{4}$ in. Takes Festoon Bulb.		CASH PRICE
No.	Finish.	EACH
D10	Ebony Black and Plated. With Bulb	15/6

TYPE D5 FESTOON LAMP.

Dimensions: $5\frac{3}{8} \times 1\frac{7}{8}$ in. Takes standard Tail Lamp Bulb.		CASH PRICE
No.	Finish.	EACH
D5	Ebony Black and Plated. With Bulb	7/6

The **Lucas Dash Lamps** are extremely neat and compact in appearance, and are ideal for use where space is limited.

Type D20 does not require a separate switch, as the knurled head of the cover serves this purpose.

Type D30 is switched on by turning the knurled head of the cover to the right. There is no direct light to distract the eyes, as a diffused light is directed through the slotted windows towards the dash or instruments by the neat cone reflector arrangement in the head of the lamp. The top of the lamp pulls off for replacement of bulb, and this also allows direct illumination from the bulb.

TYPE D20 DASH LAMP. Takes standard Tail Lamp Bulb.		CASH PRICE
No.	Finish.	EACH
D20	Ebony Black and Plated Parts. With Bulb	5/-

D20	Nickel Plated. With Bulb	5/-
------------	---	------------

TYPE D30 DASH LAMP. Takes standard Tail Lamp Bulb.		CASH PRICE
No.	Finish.	EACH

D30	Ebony Black and Plated Parts. With Bulb	5/-
------------	--	------------

D30	Nickel Plated. With Bulb	5/-
------------	---	------------

¶ Finish required must be specified when ordering.

POSTAGE EXTRA.



DASH LAMP
TYPE D20



FESTOON DASH LAMP
TYPE D10



FESTOON DASH LAMP
TYPE D5

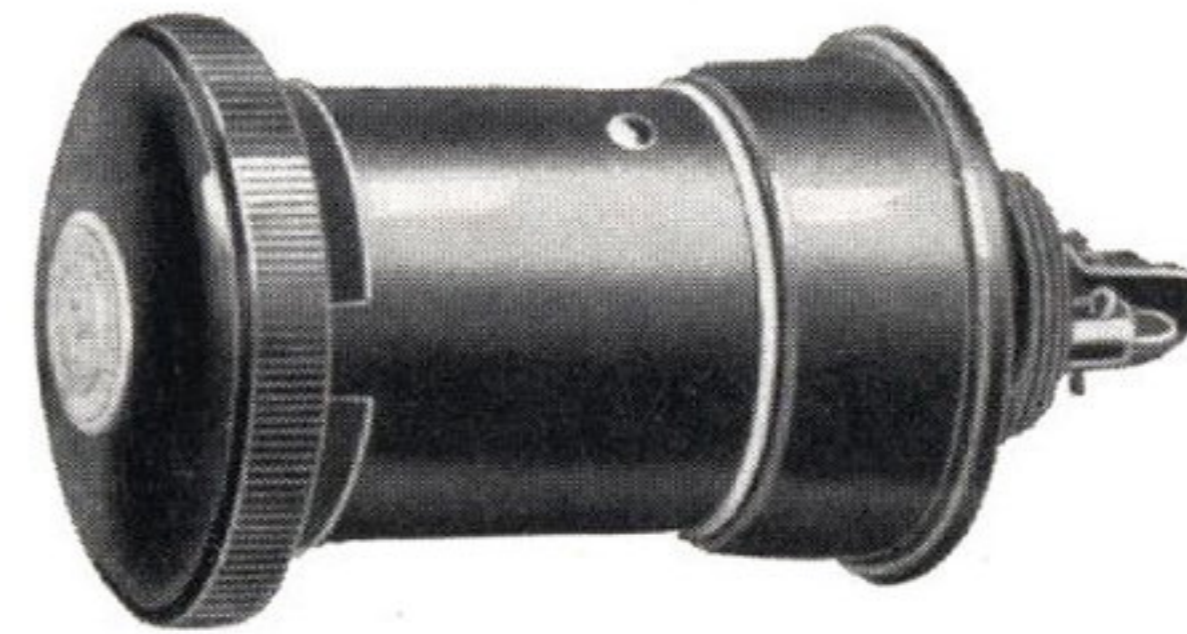

DASH LAMP
TYPE D30

LUCAS SPARE BULB CASE



SPARE BULB CASE No. 12C WITH CLIP

The Lucas No. 12C Spare Bulb Case is designed for holding a spare set of Electric Bulbs, which should always be carried for use in case of emergency. The bulbs are retained in the end covers as shown. A spring clip is provided which enables the bulb case to be secured in any convenient position, such as to the woodwork inside the side-car, or to the lid of the tool-box, etc., just as required.

The Case holds one Head Lamp bulb and four small bulbs.

Dimensions of Case : Length, $5\frac{1}{2}$ in. ; Diameter, $2\frac{3}{4}$ in.

No.								CASH PRICE EACH
12C	With Spring Clip.	Without Bulbs	5/6
12	Without Spring Clip.	Without Bulbs	4/6
	Clip only	1/-	each.

POSTAGE EXTRA.

LUCAS ELECTRIC BULBS FOR MOTOR-CYCLE LAMPS

All these Bulbs have our specially designed Metallic Filaments, which give the best results when used in combination with Lucas Lamps.

6-VOLT (EARTH RETURN) BULBS.

Code Word	No.	Volts	Watts	Approx. C.P.	Dia. Bulbs	Suitable for	CASH PRICE EACH
FAHEFE	‡8S	6	3	3	23 mm.	Pilot Bulb in SS47 Head Lamps, Side-Car and Tail Lamps	1/6
FAHEGO	‡*D69	6	9 & 3	9 & 3	40 mm.	Head Lamps in Battery Sets	3/6
FAHUK	†2S	6	18	30	38 mm.	SS47 Head Lamp in "Magdyno" Sets ..	2/9
FAHEBI	‡66F	6	6	6	—	Festoon Dash Lamp Type Dio	3/-
‡ Vacuum. * Double Filament: One for use as driving light, and an auxiliary filament of lower candle-power for use when driving light is not required. † Gas-filled.							
FAHYC	Pilot Bulb	Volts 3-5	Amps. .15	M.E.S. Cap	Pilot Bulb in MC440 Head Lamp		6d.

POSTAGE EXTRA.

LUCAS "MILAM" (ALL MOULDED) RADIO BATTERIES

("MILAM" MEANS MOULDED IN LUCAS ACID-PROOF MATERIAL)

The new Lucas Radio Batteries are moulded in "Milam," and its use enables the outside covering to be moulded integral with the cells—this prevents leakage of acid and gives great mechanical strength to the Battery. A separate case or crate is not required.

The finish of this material resembles polished ebony, and the consequent handsome appearance of Lucas Radio Batteries, besides making them an acquisition to the highest quality sets, warrants their being placed in any room where a wireless cabinet is installed.

The large bore vents are clean and effective, and the terminals robust. Another special feature is the strong carrier (with its neat and positive attachment) which facilitates handling of the Battery—a boon when it needs recharging.

The cells of the 6-volt Batteries are grouped so that they can be used for 2, 4, or 6 volts. Types RP5/6, RH5, RO5/6, RP7/4, RP5/4, RO5/4, RP7/2, RP5/2, and RO5/2 are specially suitable for Dull-emitter Valves.

Full information regarding charging and maintenance is provided with every Battery, and it should be particularly noted that prices include cover and special carrier for Battery.

LUCAS "MILAM" LOW TENSION RADIO BATTERIES. Prices include Cover and Carrier.

Type.	Volts.	DIMENSIONS.			Actual Capacity at 20 hour rate of discharge. Amp. hours.	Intermittent Rate. Amp. hours.	Cash Price each (dry).		
		Length.	Width.	Height (less carrying strap).			£	s.	d.
RM9	6	† 12	5 1/8	11 1/4	90	180	4	10	6
RP7/6	6	† 9 1/4	5 1/8	9	50	100	3	2	6
*RP5/6	6	† 7 1/4	5 1/8	9	30	60	2	4	0
*RH5	6	5 1/4	5 1/8	5 5/8	16	32	1	11	6
*RO5/6	6	6 1/8	3	7 3/8	12	24	1	8	6
*RP7/4	4	† 7 1/4	5 1/8	9	50	100	2	2	0
†*RP5/4	4	5 3/8	4 3/8	8 1/8	30	60	1	12	6
†*RO5/4	4	4 1/2	2 7/8	6 1/2	12	24	1	0	6
*RP7/2	2	5 3/8	2 3/4	8 1/8	50	100	1	2	6
*RP5/2	2	5 3/8	2 3/8	8 1/8	30	60		16	6
*RO5/2	2	2 7/8	2 1/4	6 1/2	12	24		11	0

6-volt batteries have connections for 2, 4, or 6 volts.

* These Batteries are specially suitable for use with Dull-emitter Valves.

† These Batteries consist of two 2-volt Batteries, connected and assembled in a case-carrier.

‡ These lengths include the carrying lugs.

Non-corrosive cup terminals of special design are now fitted to these Batteries.

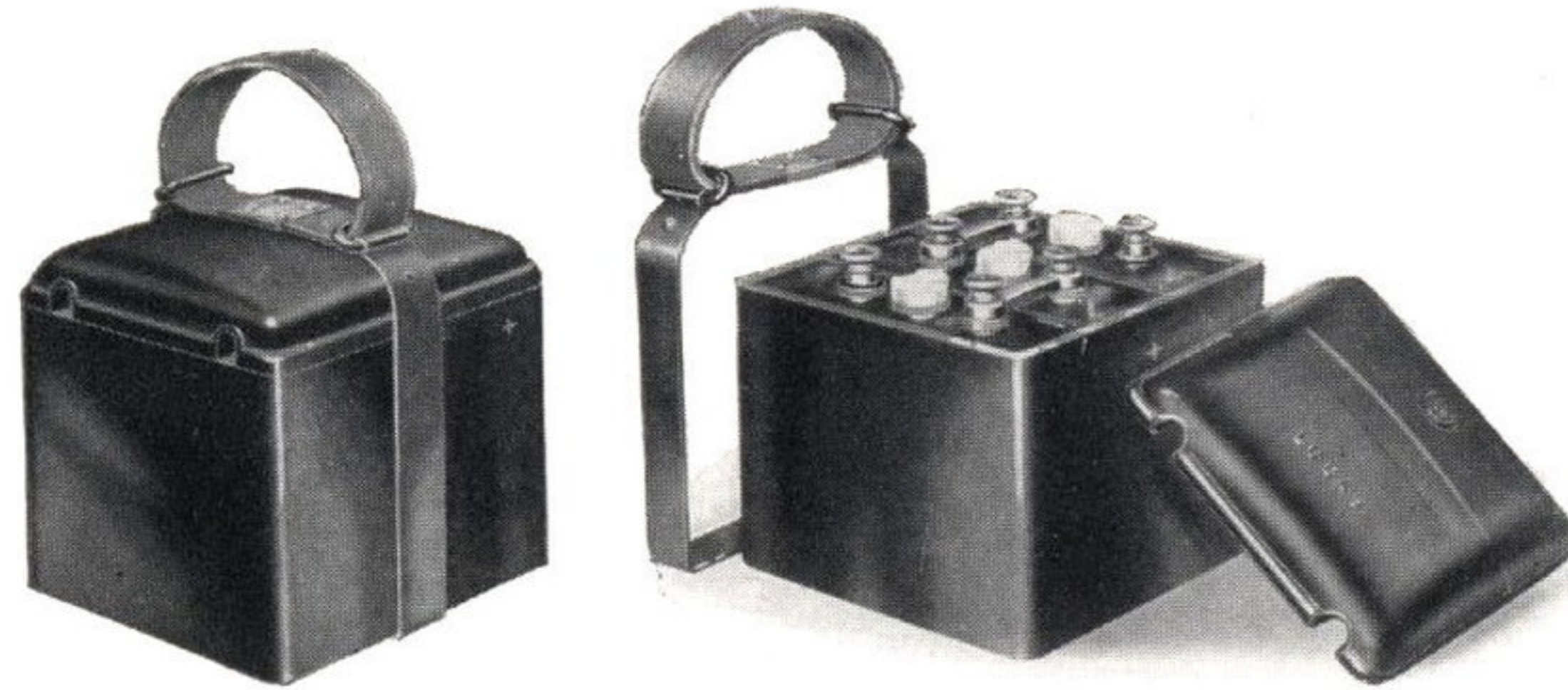
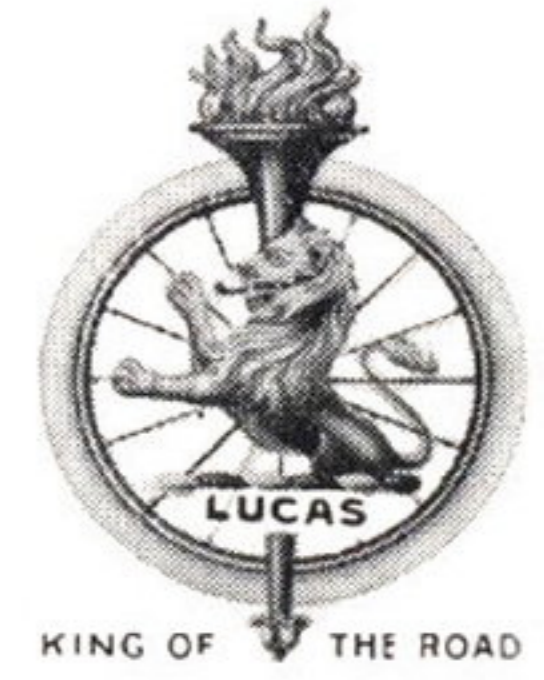

TYPE RM5

LUCAS "MILAM"
RADIO BATTERIES

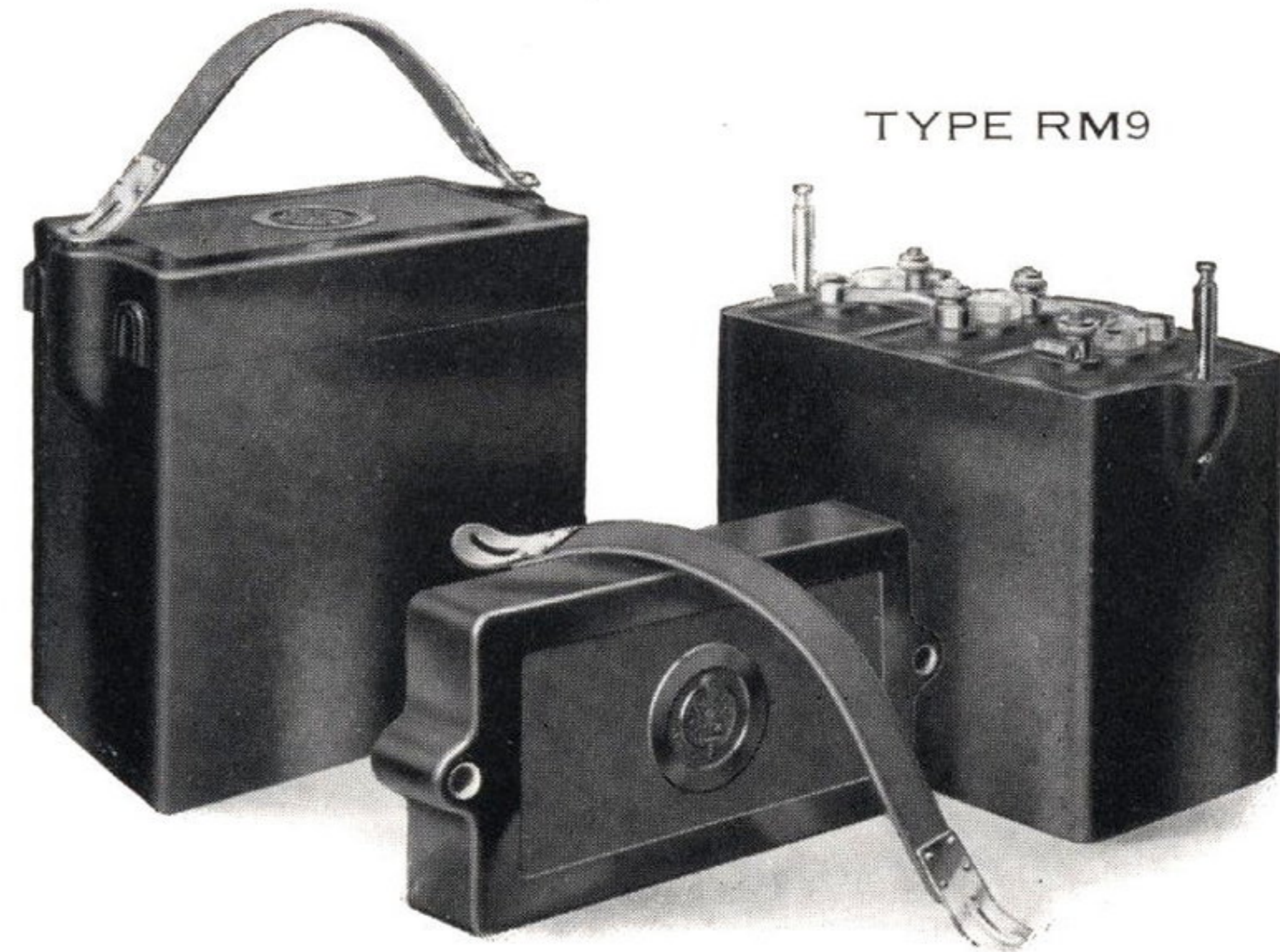

TYPE RM9

LUCAS MAGNETOS

FOR MOTOR-CYCLES

October, 1927

All previous lists cancelled.

For Light-weight Engines.

		CASH PRICE
		EACH
		£ s. d.
No. MA1	For small Single-Cylinder Engines.. .. .	3 15 0
No. MA2	For small Two-Cylinder Engines (Cylinders side by side or horizontally opposed)	4 2 6

For Medium Motor-Cycle Engines.

No. KSA1	Single-Cylinder Type	4 2 6
No. KSA2	Two-Cylinder Type (for Cylinders side by side or horizontally opposed)	4 10 0

For Large Motor-Cycle Engines.

No. KL1	Single-Cylinder Type	4 12 6
No. KL2	Two-Cylinder Type (for Cylinders side by side or horizontally opposed)	5 0 0
No. KLV	Two-Cylinder Type (for V Engines)	5 0 0

For Racing Motor-Cycle Engines.

No. KR1	Single-Cylinder Type	5 15 0
No. KRV	Two-Cylinder Type	6 2 6

(State degrees of angle in case of V Engines.)

SPARES

FOR LUCAS LAMPS IN "MAGDYNO," DYNAMO AND BATTERY SETS

HEAD LAMPS R45, RS45, SR45, SS45, R515, RS515.		Price				Price	
		s.	d.			s.	d.
Front Rim with "Difusa" Glass for Nos. R45, RS45, SR45, SS45		8	6	Bulb, Double Filament (D69)		3	6
	each			Hexagon Nut for fixing Lamps MB31, SR35 to Brackets		4	
Front Rim with "Difusa" Glass for Nos. R515, RS515		5	6	Switch Cover Plate		9	
	"			Washer and Spring Cup for switch fixing ..		2	
Glass only, "Difusa," for Nos. R45, RS45, SR45, SS45		2	6	Cheese-headed Screw		2	
	"			Terminal Grub Screws		9	doz.
Glass only, "Difusa," for Nos. R515, RS515		1	9	Ammeter Container		6	each
Bulb (double filament D618 and D612), 6 volt		3	6	Ammeter		7	6
	"						
Hexagon Nut for fixing Lamp to Bracket for R45, SR45, R515		4		SIDE-CAR LAMP R330S.			
	"			Front Rim and Glass		2	6
Ammeter Container		6		Glass only		3	
	"			Bulb 6 volt No. 8S		1	6
Ammeter		7	6	Spigot Bolt		4	
	"			Spigot Nut		2	
Spigot Bolts R45, R515		8					
	"			TAIL LAMP MT110.			
Spigot Nuts R45, R515		4		Back half complete with Bulb		5	9
	"						
HEAD LAMPS MB31, MS31, SR35, SS35, and SS30M.				Back half with Adapter only		4	3
Front Rim with "Difusa" Glass for Nos. MB31, MS31, SR35, SS35, SS30M		5	6	Front half complete		3	0
	each			Cable Nut		3	
Glass only, "Difusa," for Nos. MB31, MS31		1	9				
	"						

POSTAGE EXTRA.

LUCAS SERVICE DEPÔTS

For the convenience of users of all Lucas articles—particularly Lighting Sets and Magnetos—we have established the undermentioned Service Depôts, where urgent repairs and general overhauls will be dealt with by experienced staffs.

BELFAST	-	-	-	-	-	-	-	-	-	3/5, CALVIN STREET, MOUNTPOTTINGER
Telegrams:	"SERVDEP, BELFAST"	-	-	-	-	-	-	-	-	Telephone: BELFAST 7017
BIRMINGHAM	-	-	-	-	-	-	-	-	-	GREAT HAMPTON STREET
Telegrams:	"LUCAS, BIRMINGHAM"	-	-	-	-	-	-	-	-	Telephone: NORTHERN 2201 (10 lines)
BRISTOL	-	-	-	-	-	-	-	-	-	25, TEMPLE STREET
Telegrams:	"KINGLY, BRISTOL"	-	-	-	-	-	-	-	-	Telephone: BRISTOL 8400 (3 lines)
CARDIFF (Opening shortly)	-	-	-	-	-	-	-	-	-	PENARTH ROAD
Telegrams:		-	-	-	-	-	-	-	-	Telephone:
COVENTRY	-	-	-	-	-	-	-	-	-	PRIORY STREET
Telegrams:	"LUCAS, COVENTRY"	-	-	-	-	-	-	-	-	Telephone: COVENTRY 3068 & 3841
DUBLIN	-	-	-	-	-	-	-	-	-	41, MIDDLE ABBEY STREET
Telegrams:	"AUTOLITE, DUBLIN"	-	-	-	-	-	-	-	-	Telephone: DUBLIN 653
GLASGOW	-	-	-	-	-	-	-	-	-	227/229, ST. GEORGE'S ROAD
Telegrams:	"LUCAS, GLASGOW"	-	-	-	-	-	-	-	-	Telephone: DOUGLAS 3075 (3 lines)
LEEDS	-	-	-	-	-	-	-	-	-	64, ROSEVILLE ROAD
Telegrams:	"LUSERDEP, LEEDS."	-	-	-	-	-	-	-	-	Telephone: LEEDS 28591 (5 lines)
LONDON	-	-	-	-	-	-	-	-	-	DORDRECHT ROAD, ACTON VALE, W. 3.
Telegrams:	"DYNOMAGNA, ACT, LONDON"	-	-	-	-	-	-	-	-	Telephone: CHISWICK 3801 (18 lines)
LONDON	-	-	-	-	-	-	-	-	-	759, HIGH ROAD, LEYTON, E. 10
Telegrams:	"LUSERDEP, WALT, LONDON"	-	-	-	-	-	-	-	-	Telephone: WALTHAMSTOW 2161 (2 lines)
LONDON	-	-	-	-	-	-	-	-	-	155, MERTON ROAD, WANDSWORTH, S.W. 18
Telegrams:	"LUSERV, WANDS, LONDON"	-	-	-	-	-	-	-	-	Telephone: PUTNEY 5131 (4 lines) & 5501
MANCHESTER	-	-	-	-	-	-	-	-	-	TALBOT ROAD, STRETFORD
Telegrams:	"LUCAS, STRETFORD"	-	-	-	-	-	-	-	-	Telephone: TRAFFORD PARK 1410 (3 lines)
NEWCASTLE-ON-TYNE	-	-	-	-	-	-	-	-	-	64-66, ST. MARY'S PLACE
Telegrams:	"MOTOLITE, NEWCASTLE-ON-TYNE"	-	-	-	-	-	-	-	-	Telephone: CENTRAL 3571 (3 lines)

In addition there are Battery Service Agents in most centres.

LUCAS

MOTOR-
CYCLEALITIES

ELECTRICAL & NON-ELECTRICAL

1928



KING OF THE ROAD