

LUCAS EQUIPMENT FOR 1964 BRITISH MOTOR CYCLES

CONTENTS

	<i>Page</i>
Alternator and Parts	7
Ammeter	9 and 11
Battery	15
Bulbs.	16
Contact Breaker and Parts (including Distributor).	6
Diode, Zener	8 and 10
Generator and Parts	4-5
Headlamp and Parts	10-13
Horn and Bracket	8 and 10
Ignition Coil	6
Magdyno and Parts	4-5
Magneto and Parts	2-3
Motor Cycle Model Reference	19
Reflex Reflector	15
Pilot Lamp and Parts	16
Starter and Parts	4-5
Stop Tail and Number Plate Lamp and Parts	14-15
Switches	8-11
GIRLING EQUIPMENT.	17







For additional details apply to Lucas Agents

JOSEPH LUCAS (EXPORT) LIMITED . 46 PARK STREET, LONDON W.1

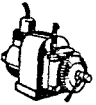
MAGNETO AND PARTS

1964







SPECIFICATIONS

		1	2	3	4		5	6
		MAGNETO	CLIP ASSEMBLY, PICK-UP	RUBBER COVER, PICK-UP	PICK-UP ASSEMBLY		BRUSH AND SPRING PICK-UP	
MAKE AND MODEL								
(1)	A.M.C. (A.J.S. and MATCHLESS) Twin cyl. Competition Models (31 'Swift' and G12 'Majestic', optional)	42264D	455734	458658	458367	458368	451260	
	(2) Single cyl. Competition Models	42347E	455733	457810		456794	451260	
(3)	ENFIELD 736 c.c. 'Interceptor' (6 and 12 volt)	42442A		458658	458367	458368	451260	
	NORTON 'Atlas' (approximately first 150 machines)	42452A	455734	458658	458367	458368	451260	
(5)	'Dominator' 885S and 650SS, 'Manxman' and 'Atlas'	42368D	455734	458658	458876	458876	451260	4512
(6)	'Dominator' 885S and 650SS, 'Manxman' and 'Atlas' (later)	42379B/D			458865	458866	451260	
(7)	PANTHER 100 and 120	46047B	See Magdyno					











MAGNETO AND PARTS continued

1964











SPECIFICATIONS

		17	18	19	20	21	22
		MAGNETO	CUP, INSULATING, BEARING	NUT, SHAFT	ARMATURE	SLIP RING	CONDENSER
MAKE AND MODEL							
(1)	A.M.C. (A.J.S. and MATCHLESS) Twin cyl. Competition Models (31 'Swift' and G12 'Majestic', optional)	42264D	451379	170109	459004	455361	458339
	(2) Single cyl. Competition Models	42347E	463932	170109	493176	464277	454415
(3)	ENFIELD 736 c.c. 'Interceptor' (6 and 12 volt)	42442A	451379	170109	459142	454497	458339
	NORTON 'Atlas' (approximately first 150 machines)	42452A	451379	170109	459004	455361	458339
(5)	'Dominator' 885S and 650SS, 'Manxman' and 'Atlas'	42368D	463932	170109	459376	456727	458339
(6)	'Dominator' 885S and 650SS, 'Manxman' and 'Atlas' (later)	42379B/D	451379		459004	455361	458339
(7)	PANTHER 100 and 120	46047B	See Magdyno				

MAGNETO AND PARTS

	7	8	9	10	11	12	13	14	15	16
	NUT, H.T. CABLE	COVER, CONTACT BREAKER	CONTACT BREAKER	CONTACT SET	BRUSH AND SPRING, C.B. EARTHING	CONTROL PARTS, SET	RUBBER COVER, CONTROL SET	CAM	SPRING AND PIN, C.B. COVER	PLATE, HOUSING, C.B. END
										
(1)	410600	458619	492854	54440888		463107	454475	458725	458613	458726
(2)	410600	459199	492854	54440888		459305	454475	459321		459313
(3)	410600	458619	493836	54440887				459131	458613	459105
(4)	410600	458619	492854	54440888	455190			459130		
(5)	410600	459205	492854	54440888	455190			459130		493716
(6)	410600	459269	492854	54440888	455190			459130		
(7)										







MAGNETO AND PARTS *continued*

	23	24	25	26	27	28	29	30	31	32
	BEARING, C.B. END	BEARING, DRIVE END	BRUSH, SPRING AND HOLDER, EARTHING	BRUSH AND SPRING, EARTHING	SPRING AND PIN, PICK-UP	OIL SEAL	CUP, INSUL., D.E. BEARING	SUNDRY PARTS SET	AUTO-ADVANCE UNIT	SPRINGS SET A.-A. UNIT
										
(1)	189291	189244	455191	455190	458370	459002	459005	458675		
(2)	189294	189294	455191	455190		459033	463932	454697		
(3)	189291	189244	455191	455190	458370	459002	459005	458675	47613A	498157/S
(4)	189291	189244	455191	455190	458370	459002	459005	458675	47508D	498157/S
(5)	189294	189244	455191	455190		459002	459005	458675	47508D	498157/S
(6)	189291	189244	455191	455190	458370	459002	459005	458675	47508D	498157/S
(7)										

GENERATOR AND PARTS

1964







SPECIFICATIONS

MAKE AND MODEL		33	34	35	36	37	38
		GENERATOR	BRUSH SET	BRACKET, C.E.	BEARING, C.E.	INSUL. PLATE WITH BRUSHGEAR	BRUSH SPRING
(1)	PANTHER 100 and 120	 20034A 37225J/K RB108 †54381654	 200737	 200713/5	 189210	 200911	 220197
		*Control box †Cover					

STARTER AND PARTS

1964









SPECIFICATIONS

MAKE AND MODEL		48	49	50	51	52	53
		STARTER	BOLT	BRUSH SET	BRACKET, C.E.	BEARING BUSH	THRUST PAD
(1)	B.S.A. 250 c.c. B2S ('Sunbeam' Scooter, 12 volt)	 26501E	 54250291	 54250595	 54252306	 261233	 —
(2)	NORTON 397 c.c. 'Electra'	26509A	54254142	54252361	54254127	261233	54252180
(3)	TRIUMPH 250 c.c. TW2S ('Tigress' Scooter, 12 volt)	26501E	54250291	54250595	54252306	261233	—









MAGDYNO AND PARTS

1964



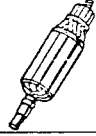



SPECIFICATIONS

MAKE AND MODEL		64	65	66	67	68	69	70	71	72
		MAGDYNO	GENE-RATOR	MAGNETO PORTION	STRAP ASSEMBLY	PICK-UP	NUT, MOULDED	COVER, CONTACT BREAKER	CONTACT BREAKER	CONTACT SET
(1)	PANTHER 100 and 120	 46047B	 20034A	 464243	 460056	 463066	 410600	 460061	 460051	 484098



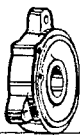

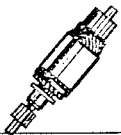
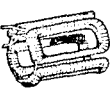

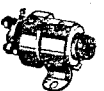





GENERATOR AND PARTS

	39	40	41	42	43	44	45	46	47
	C.E. COVER	BEARING, D.E.	BRACKET, D.E.	SHAFT NUT SCREW, GEAR RETAINING	GEAR, DRIVING	ARMATURE	FIELD COIL	THROUGH BOLT	SUNDRY PARTS SET
									
(1)	200923	189307	200912	111704	454495	200754	200731	200732	200806

STARTER AND PARTS

	54	55	56	57	58	59	60	61	62	63
	LINER INSUL.	PLATE, BRUSH BOXES	SPRING SET	BRACKET, D.E.	BEARING BUSH	ARMATURE	FIELD COIL	FIELD TERMINAL	SUNDRY PARTS SET	SWITCH OR SOLENOID
										
(1)	—	54250751	54250596	54250271	54250347	54250289	54250753	54250479	54251434	76463A
(2)	54251728	54251740	54252360	54255890	54255274	54255281	54251462	54251387	54252417	76464E
(3)	—	54250751	54250596	54250271	54250347	54250289	54250753	54250479	54251434	76463A









MAGDYNO AND PARTS

	73	74	75	76	77	78	79	80	81	82	83	84	85
	JUMP RING	CAM	CONTROL PARTS SET	SPRING PIN	END PLATE, C.B.	CUP, INSUL., C.E. & D.E.	BEARING, C.B. & D.E.	END PLATE, D.E.	GEAR SET	ARMA-TURE	SLIP RING	BRUSH, SPRING & HOLDER	BRUSH & SPRING
													
(1)	455347	493181	463107	463899	464255	*451379 †463932	*189291 †189294	463989	462863	464205	454496	455191	455190
						*Contact breaker end †Drive end	*Contact breaker end †Drive end						

CONTACT BREAKER AND PARTS (including Distributor)

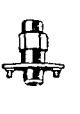



Ignition Coil

1964 SPECIFICATIONS

		86	87	88	89	90	91	92	93	94
MAKE AND MODEL		CONTACT BREAKER	CON- DENSER	CONTACT SET	BASE, CONTACT BREAKER	CAM	A.A. SPRINGS	A.A. WEIGHTS	SHAFT & ACTION PLATE	IGNITION COIL
										
A.M.C. (A.J.S. and MATCHLESS)										
(1)	A.J.S. 16; Matchless G3 (350 c.c.) ...	47618A	425377	54415803	425370	54440029	54413020	54440031	54416205	45152A/B
(2)	A.J.S. 18; Matchless G80 (500 c.c.) ...	47615A	425377	54415803	425370	54440029	54415640	54440031	54415749	
(3)	A.J.S. 31; Matchless G12 (coil ignition)	47617A	425377	54415803	425370	54441729	54413020	425359	425354	45110A/D
ARIEL										
(4)	'Arrow' and 'Leader' ...	425739	425377	54415803	425370					45152B
B.S.A.										
(5)	B2 'Sunbeam' Scooter (6 volt) ...	47583B	425377	54415803	425370	54440029	54413020	54440031	54440032	45152A/B
(6)	B2S 'Sunbeam' Scooter (12 volt) ...	47583B	425377	54415803	425370	54440029	54413020	54440031	54440032	45101A
(7)	C15 and SS80 250 c.c., B40 and B40SS90	*40867A ‡54411737 ‡405314 ‡421109	421327	421106		421206	54412018	421056	421054	45152A/B
(8)	C15T and C15S Competition ...	*40868A ‡54411737 ‡405314 ‡421109	421327	421106		54415051	54412018	421056	421054	45149B
(9)	A50, A65, A65R and A65 'Lightning Rocket' ...	47583B	425377	54415803	425370	54440029	54413020	54440031	54440039	45077E *45152A/B ‡45110A/D
(10)	A50 'Cyclone' and A65 'Spitfire-Hornet'	47612A	425377	54415803	425370	54415053	54415641	54440031	54416124	45150A (left hand) 45149B (right hand)
ENFIELD										
(11)	250 c.c. and 350 c.c. ...	47609A	54413002	420196	465958	465939	421457/S	415730	469107	45152B
TRIUMPH										
(12)	TW2 'Tigress' (6 volt) ...	47583B	425377	54415803	425370	54440029	54413020	54440031	54440032	45152A
(13)	TW2S 'Tigress' (12 volt) ...	47583B	425377	54415803	425370	54440029	54413020	54440031	54440032	45101A
(14)	T20 and T20SH ...	47604B	425377	54415803	425370	54440029	425768	54440031	54415655	45152A
(15)	Ditto (later) ...	47615A	425377	54415803	425370	54440029	54415640	54440031	54415749	
(16)	T20R and T20S ...	47603B	425377	54415803	425370	54415053	54415640	54440031	54415749	45112D *45149B
(17)	3TA 'Twenty-one' and 5TA 'Speed Twin'	47606B	425377	54415803	425370	54441729	54412550	425359	54415753	45152A
(18)	Ditto (later) ...	47605B	425377	54415803	425370	54441729	54415642	425379	54415751	
(19)	T90 and T100 ...	47606B	425377	54415803	425370	54441729	54412550	423359	54415753	45152A
(20)	Ditto (later) ...	47605B	425377	54415803	425370	54441729	54415642	425379	54415751	
(21)	TR6, T120 and 6T ...	47605B	425377	54415803	425370	54441729	54415642	425379	54415751	45152A ‡45110D 45150A (left hand) 45149B (right hand)
(22)	T100SC ...	47602B	425377	54415803	425370	54415473	54415641	425359	54415747	
		*Distributor ‡Cover ‡Terminal §Bush, terminal insul.								*Later ‡A65 (12 volt) ‡6T only

ALTERNATOR AND PARTS

1964 SPECIFICATIONS

		95	96	97	98	99
MAKE AND MODEL		*ALTERNATOR	ROTOR	STATOR	CABLE CLIP	RECTIFIER
						
(1)	A.M.C. (A.J.S. and MATCHLESS) A.J.S. 16, 18 and 31; Matchless G3, G80 and G12	54021023	54213901	47181	54210167	49072A
(2)	A.J.S. 18CS and 31CSR; Matchless G80CS and G12CSR	54021027	54213901	47162A	54210167	49072A
(3)	A.J.S. 31; Matchless G12 (magneto ignition) and G15CS	54021027	54213901	47162A	54210167	49072A
(4)	ARIEL All Models	54021025	54213903	47161	54213907	49072A
B.S.A.						
(5)	B2 ('Sunbeam' Scooter, 6 volt)	047540	54210940	47136B		49072A
(6)	B2S ('Sunbeam' Scooter, 12 volt)	54021000	54210946	47135A		47128A
(7)	C15 'Star' and SS80	54021025	54213903	47161	54213907	49072A
(8)	C15S and C15T	54021039	54213901	47173	54210167	
(9)	B40 'Star' and B40SS90	54021023	54213901	47181	54210167	49072A
(10)	A50 and A65 'Star'	54021023	54213901	47181	54210167	49072A
(11)	A65R 'Rocket' and A65 'Lightning Rocket'	54021023	54213901	47181	54210167	49072A
(12)	A50 'Cyclone' and A65 'Spitfire-Hornet'	54021056	54213901	47188	54211644	
ENFIELD						
(13)	All Models except 'Interceptor'	54021025	54213903	47161A	54213907	49072A
(14)	'Interceptor'	54021023	54213901	47181	54210167	49072A
NORTON						
(15)	88SS and 650SS 'Atlas' and 'Manxman'	54021027	54213901	47162A		49072A
TRIUMPH						
(16)	TW2 ('Tigress' Scooter, 6 volt)	047540B	54210940	47136		49072A
(17)	TW2S ('Tigress' Scooter, 12 volt)	54021000	54210946	47135		47128B
(18)	T20 and T20SH	54021025	54213903	47161	54213907	49072A
(19)	T20R and T20S	54021039	54213901	47173	54210167	
(20)	3TA, 5TA, T100 and T90	54021023	54213901	47181	54210167	49072A
(21)	T100SC	54021056	54213901	47188	54211644	
(22)	T100SC (later)	54021079	54213901	47188A	54211644	
(23)	TR6 and T120 (U.S.A. only)	54021027	54213901	47162	54210167	49072A
(24)	TR6 and T120	54021023	54213901	47181	54210167	49072A
(25)	6T	54021027	54213901	47162	54210167	49072A





*Alternator serviced by Rotor and Stator

1964 SPECIFICATIONS

HORN







Diode, Zener 102

SWITCHES

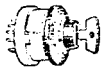
		100	101		102	103	104
MAKE AND MODEL		HORN	MODEL	BRACKET	DIODE, ZENER	PANEL	LIGHTING
							
A.M.C. (A.J.S. and MATCHLESS)							
(1)	A.J.S. 16 and 18; Matchless G3 and G80 ...	70163A/B	8H	54680850			34289A
(2)	A.J.S. 18CS; Matchless G80CS ...	70163A/B	8H	54680850			34289A
(3)	A.J.S. 31CSR; Matchless G12CSR ...	70159D	6H		49345A		34289A
(4)	A.J.S. 31; Matchless G12 and G15CS ...	70159D	6H		49345A		34289A
ARIEL							
(5)	'Arrow' and 'Super Sports' ...	70178A	8H	54680850		*31820A	34289A
(6)	'Leader' ...	70178A	8H	54680850		*31820A †31823A	34289A
B.S.A.							
(7)	175 c.c. B1 ('Sunbeam' Scooter) ...	70166A/B	8H				
(8)	250 c.c. B2 ('Sunbeam' Scooter, 6 volt) ...	70166A/B	8H				34289A
(9)	250 c.c. B2S ('Sunbeam' Scooter, 12 volt) ...	70177A	8H				54033028
(10)	C15 'Star', SS80 'Star', B40 'Star' and B40 SS90 ...	70169A/B	8H	44680850			34289A
(11)	C15T and C15S Competition ...						31356A/B
(12)	A50, A65 'Star' Twin, A65R and A65 'Lightning Rocket' ...	70169A/B *70164A/B †70161E	8H 8H 6H	54680850 54680850	*49345A		34289A
(13)	A50 'Cyclone' and A65 'Spitfire-Horner' ...						31356A/B
ENFIELD							
(14)	250 c.c. 'Clipper', 'Crusader Sports' and 'Continental' ...	70163A	8H	54680850			*31784A/D 34289A
(15)	250 c.c. 'Turbo Twin' ...	70163A	8H	54680850			34289A
(16)	350 c.c. 'Bullet' ...	70163A	8H	54680850			*31784A/D 34289A
(17)	736 c.c. 'Interceptor' (6 and 12 volt) ...	70163A †69133A	8H 9H	54680850	†49345A		31491A *31784A/D †34289A
FRANCIS-BARNETT							
(18)	'Falcon', 'Cruiser' and 'Sports Cruiser' ...	70163A/B	8H	54680850			
JAMES							
(19)	'Comet' ...						
(20)	'Captain', 'Sports Captain', 'Sports Superswift' and 'Scooter' ...	70163A/B	8H	54680850			
NORTON							
(21)	250 c.c. 'Jubilee' and 350 c.c. 'Navigator' ...	70163A/B	8H	54680850			
(22)	497 c.c. 8855, 650 c.c. 55 'Dominador', 650 c.c. 'Manxman' (U.S.A.) and 750 c.c. 'Atlas' (U.S.A.) ...	70159B/D	6H		49345A		34289A
(23)	397 c.c. 'Electra' ...	70164A/B	8H	54680850			
PANTHER							
(24)	'Princess' Scooter (6 volt) ...						31758D
(25)	249 c.c. 35 and 45 Sports ...						31784D
(26)	600 c.c. 100 and 650 c.c. 120 ...	069498	HF1234	700168			31754B
		*A65 (12 volt) †A65R and 'Lightning Rocket' ‡12 volt			*A65 (12 volt) †12 volt	*Neutral gear indicator †Flasher switch	*'Airflow' †Later

SWITCHES

Ammeter

	105	106	107	108	109	110	111	112
	KNOB (LIGHTING)	CUTOUT OR IGNITION	RUBBER COVER	DIPPER	HORN PUSH	STOP LAMP	SPRING, STOP LAMP	AMMETER
								
(1)	54330934	34427B	54336178		*31563D	31383A/B		36296A
(2)	54330934				*31563D	31384B	315543	36296A
(3)	54330934	76204D			*31563D	31383A/B		36296A
(4)	54330934	34427B *76204D	54336178		*31563D	31383A/B		36296A
(5)	54330934	34427A/B	54336178	31549B	76234A	54033234		36084F
(6)	54330662	34427A/B	54336307	31549B	76234A	31384B 54033234		36084F
(7)								
(8)	54331482	34427A/B	54336308		*31563D	31437B		
(9)	54331482	54033027	*54331351	*76463A	*31563D	31437B		
(10)	*54330485 54330934	34427A	54336178			31827A		36084F
(11)		76204D		31620E	†76204D			
(12)	*54330485 54330934	34427A	54336178			34448B		36296A
(13)		31071D		31620A/E	76204A/B	34448A/B		
(14)	351815 54330934	†34093B 34427A	54336178	†31549B	†76204D *31563D	31688A/B		36084F *36296A
(15)	54330934				*31563D	31688A/B		
(16)	351815 54330934	†34093B 34427A	54336178	31549B	76204D	31688A/B		36084F
(17)	351567 351815 54330934	76204D		31549B	76204D *§31563D	31688A/B		36084F †36296A
(18)						*31511A/B		
(19)				31549A/B				
(20)								
(21)								
(22)	54330934	76204D			*31563D	31383B		36296A
(23)								
(24)	351815					31437D	315738	36084F
(25)	351815				*31563D	31437D	315543	36084F
(26)	351815				*31563D	31437D	315738	36084F
	*Escutcheon plate	*When fitted †'Airflow'	*Knob, ignition	*Starting motor †'Crusader'	*Horn push and dipper †Optional ‡'Crusader' §U.S.A.	*Not 'Sports Cruiser'		*'Continental' †'Interceptor' (U.S.A.)





continued

1964 SPECIFICATIONS

HORN









Diode, Zener 102

SWITCHES

	MODEL	100		101	102	103		104
		HORN	MODEL	BRACKET	DIODE, ZENER	PANEL	LIGHTING	
								
(1)	TRIUMPH 'Tigress' Scooter	70166A/B	8H					34289A
(2)	'Tigress' Scooter (12 volt)	70166A/B	8H					54033028
(3)	'Tigress' Scooter	70177A	8H					31356A/B
(4)	T20R and T20	70145D	HF1950					34289A
(5)	T20	70169B	8H	54680850				34289A
(6)	T20SH	70163A/B	8H	54680850				34289A
(7)	3TA and 5TA	70163A/B	8H	54680850				34289A
(8)	TR6 and TR6A	70163A/B	8H	54680850				34289A
(9)	T100 and T100A	70145D	HF1950					31356A/B
(10)	T100SC	70164A/B	8H	54680850	49345A			34289A
(11)	6T							

HEADLAMP AND PARTS







1964 SPECIFICATIONS

	MODEL	HEADLAMPS				RIM OR DOOR	WIRE, LIGHT UNIT FIXING	SCREW, RIM FIXING	BEAD OR GROMMET
		VERTICAL DIP	DIP LEFT	EUROPE (NOT FRANCE)	FRANCE				
									
(1)	A.M.C. (Matchless) A.J.S. 16 (Matchless G3 and G80)	59171A		59172A	59173A	553248	504665	144921	
(2)	A.J.S. 16 (Matchless G80CS)	58829A/B				553248	504665	144921	*199002
(3)	A.J.S. 31 (Matchless G12CSR)	59237A		59238A	59239A	553248	504665	144921	
(4)	A.J.S. 31 (Matchless G12CSR alternative, magneto ignition)	59252A				553248	504665	144921	
(5)	A.J.S. 31 (Matchless G12CSR)	59281A				553248	504665	144921	
(6)	Matchless	59281A				553248	504665	144921	
(7)	ARIEL 'Arrow'	58892B		58976A	58896B	534343 *516723	504665 *500291	144921 *516710	*199005
(8)	'Leader'	58897A		58396A *58898A	58899A	54520003	504665	555911	
(9)	B.S.A. E2 (500 cc, 6 volt)	58975A *59004A		58976A		516723 516723	500291 500291	516710 516710	
(10)	E2S (500 cc, 12 volt)	58421D		58422D	58423D	516723 †516910	500291 †516911	516710	
(11)	C15 (550 cc, B40SS90)	*58424B 58234D		58392A	58391A	516723 534343	500291 504665	516710 144921	
(12)	C15T and C15T (550 cc)	58395F				534343	504665	144921	*199003
(13)	A50 (500 cc)	59141A	59140A	59142A	59143A	553248	504665	144921	
		*U.S.A. only		*Later		*Europe (not France) †France	*Europe (not France) †France	*Europe (not France)	*Grommet, cable entry

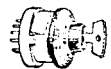





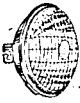

continued

SWITCHES

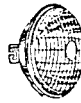
Ammeter

	105	106	107	108	109	110	111	112
	KNOB (LIGHTING)	CUTOUT OR IGNITION	RUBBER COVER	DIPPER	HORN PUSH	STOP LAMP	SPRING, STOP LAMP	AMMETER
								
(1)								
(2)	54331489	34427A/B	54336308			31437B	315738	
(3)	54331482	54033027	54331351			31437B	315738	
(4)		31071D		31620B	*31563D	31437B	315738	
(5)	54330934	34427A/B	54336178		*31563D	31437B	315738	
(6)	54330934	34427A/B	54336178	31620B	76204D	31437B	315738	
(7)	54330934	34427A/B	54336178		*31563D	31383A		36189B *36296A
(8)	54330934	34427A	54336178		*31563D	31383A		36296A
(9)	54330934	34427A	54336178		*31563D	31383A		36296A
(10)		31071D		31620B	76204D	31383A		
(11)	54330934	34427A	54336178		*31563D	31383A		36296A
					*Horn push and dipper			*Later

HEADLAMP AND PARTS

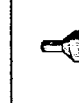
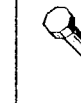
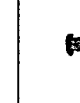







	121	122	123	124	125	126	127	128	129	130	131
	LIGHT UNITS				BULB HOLDERS OR ADAPTORS			BACKSHELL (FRANCE ONLY)	PLUG AND CABLE	SCREW, LAMP FIXING	SLEEVE, TERMINAL
	VERTICAL DIP	DIP LEFT	EUROPE (NOT FRANCE)	FRANCE	MAIN	PILOT	INTERIOR, PILOT				
											
(1)	516798		555275	516802	554602 *562303	554710	553780	552943		112201	555910
(2)	516798				554602	554710	553780		54944387	112201	555910
(3)	516798		555275	516802	554602 *562303	554710	553780	552943		112201	555910
(4)	516798				554602	554710	553780			112201	555910
(5)	516798				554602	554710	553780			112201	555910
(6)	516798				554602	554710	553780			112201	555910
(7)	54520858		516829	516912	554602 *562303	554710	553780	552943		*112201	555910
(8)	516828		516829	516912	554602 *562303	554710	553780	553470			555910
			516829		554602	554710	553780				555910
(9)	516828 54520452		516829		554602 554602	554710	553780				555910 555910
(10)	516767		516658	516912	554946 *562303	554710	553780	553470			555910
	516659				554946						555910
(11)	516828		516829	516912	554602 *553470	554710	553780				555910
(12)	54520452				554602					112201	555910
(13)	516810	516812	516811	516802	554602 *562303	554710	553780	552943			555910
					*France					*France and vertical dip	

continued









HEADLAMP AND PARTS

113 114 115 116 117 118 119 120

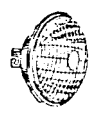
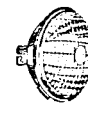
1964 SPECIFICATIONS



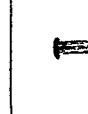

MAKE AND MODEL		HEADLAMPS				RIM OR DOOR	WIRE, LIGHT UNIT FIXING	SCREW, RIM FIXING	BEAD OR GROMMET
		VERTICAL DIP	DIP LEFT	EUROPE (NOT FRANCE)	FRANCE				
									
B.S.A.—continued									
(1)	A50 'Cyclone' and A65 'Spitfire-Hornet' ...	58395F				534343	504665	144921	*199003
(2)	A65R 'Rocket' and A65 'Lightning Rocket'	*59171A ‡59137A				553248 553248	504665 504665	144921 144921	
ENFIELD									
(3)	'Clipper', 'Crusader', 'Bullet' and 'Interceptor'	50943E ‡51756E		51112D	51134D	553248 553248	504665 504665	144921 144921	
(4)	All Models with 'Airflow' ...	58258B				554440		198898	55541
(5)	250 c.c. 'Turbo Twin' ...	59287A				534343	504665	144921	*199005
(6)	'Continental' ...	58878A				553248	504665	144921	*199002
(7)	'Interceptor' (U.S.A.) ...	58937A				553248	504665	144921	*199002
(8)	'Interceptor' (12 volt) ...	‡50943E ‡59176A				553248 553248	504665 504665	144921 144921	
NORTON									
(9)	'Dominator' 88SS and 650SS ...	59252A		59254A	59253A	553248	504665	144921	
(10)	'Manxman' and 'Atlas' ...	59281A				553248	504665	144921	
PANTHER									
(11)	'Princess' Scooter (6 volt) ...	58552A				534343	504665	144921	
(12)	35 and 45 Sports ...	58472A				534343	504665	144921	*862217 ‡199005
(13)	100 and 120 ...	58092B				553248	504665	144921	*862217 ‡517239
TRIUMPH									
(14)	'Tigress' TW2 (6 volt) ...	58975A ‡59004A		58976A		516723 516723	500291 500291	516710 516710	
(15)	'Tigress' TW25 (12 volt) ...	58421D		58422D	58423D	516723 *516910	500291 *516911	516710	
(16)	T20 ...	‡58424A/B 58975A		58976A	58977A	516723 *516910	500291 *516911	516710	
(17)	T20R, T20S and T100SC ...	‡59004A 58395B				534343	504665	144921	*199003
(18)	3TA and 5TA ...	‡51756E	51860B	51757D	51758B	553248	504665	144921	
(19)	TR6 and T120 ...	58934A				553248	504665	144921	
(20)	T100 and T90 ...	58934A				553248	504665	144921	
(21)	T20SH ...	58935A				534343	504665	144921	
(22)	6T ...	59176A		59177A	59178A	553248	504665	144921	
		*With speedo aperture ‡Less speedo aperture ‡Later §Bulb 446 ‡U.S.A. only				*France	*France		*Grommet, cable entry ‡Grommet, trip cable

HEADLAMP AND PARTS

	121	122	123	124	125	126	127	128	129	130	131
	LIGHT UNITS				BULB HOLDERS OR ADAPTORS			BACKSHELL (FRANCE ONLY)	PLUG AND CABLE	SCREW, LAMP FIXING	SLEEVE, TERMINAL
	VERTICAL DIP	DIP LEFT	EUROPE (NOT FRANCE)	FRANCE	MAIN	PILOT	INTERIOR, PILOT				
											
(1)	54520452				554602					112201	555910
(2)	516798				554602	554710	553780			112201	555910
	516798				554602	554710	553780			112201	555910
(3)	553925		553940	553948	554602			552943			555910
	516810				*562303						
	516798				554602	554710	553780				555910
(4)	516798				554602	554710	553780				555910
(5)	54520858				554602	554710	553780			112201	555910
(6)	516798				554602	554710	553780		54944387	112201	555910
(7)	516798				554602	554710	553780		54944387	112201	555910
(8)	553925				554602						555910
	516810				554602	554710	553780				555910
(9)	516798		555275	516802	554602	554710	553780	552943		112201	555910
(10)	516798				554602	554710	553780			112201	555910
(11)	516828				554602	554710	553780				555910
(12)	516828				554602	554710	553780			112201	555910
(13)	516798				554602	554710	553780			112201	555910
(14)	516828		516829		554602	554710	553780				555910
	54520452				554602						555910
(15)	516767		516658	516912	554946	554710	553780	553470			555910
					*562303						
	516659				554946						555910
(16)	516828		516829	516912	554602	554710	553780	553470			555910
					*562303						
	54520452				554602						555910
(17)	54520452				554602					112201	555910
(18)	516810	516812	516811	516802	554602	554710	553780	552943			555910
					*562303						
(19)	516798				554602	554710	553780			112201	555910
(20)	516798				554602	554710	553780			112201	555910
(21)	516828				554602	554710	553780			112201	555910
(22)	516810		516811	516802	554602	554710	553780	552943			555910
					*562303						
					*France						

STOP TAIL AND NUMBER PLATE LAMP









1964 SPECIFICATIONS

MAKE AND MODEL		132	133	134	135
		LAMP	LENS	WINDOW	NUT OR SCREW, LENS OR RIM FIXING
					
A.M.C. (A.J.S. and MATCHLESS)					
(1)	A.J.S. 16 and 18; Matchless G3 and G80	53432B	573839	575200	575219
(2)	A.J.S. 18CS; Matchless G80CS	*53432B ‡53972A/B	573839 54572932	575200	575219 572289
(3)	A.J.S. 31CSR; Matchless G12CSR	*53454B	573839	575200	575219
(4)	A.J.S. 31CSR; Matchless G12CSR and G15CS	‡53973A/B	54572932		572289
(5)	A.J.S. 31; Matchless G12	53454B	573839	575200	575219
ARIEL					
(6)	All Models... ..	53394B	573839	575200	575219
B.S.A.					
(7)	B1 ('Sunbeam' Scooter)	53432B	573839	575200	575219
(8)	B2 ('Sunbeam' Scooter, 6 volt)	*53432B ‡53972A/B	54572932		572289
(9)	B2S ('Sunbeam' Scooter, 12 volt)	53454B	573839	575200	575219
(10)	'Bantam' and 'Bantam Super'	53394B	573839	575200	575219
(11)	C15 and SS80	‡53972A/B	54572932		572289
(12)	C15S and C15T	§53432B § 53825A	573839 573839	575200 575200	575219 575219
(13)	B40, B40SS90, A65 'Lightning Rocket' and A65R 'Rocket'	53432B	573839	575200	575219
(14)	A50 and A65 'Star'	‡53972A/B	54572932		572289
(15)	A50 'Cyclone' and A65 'Spitfire-Hornet'	53394B ‡53972A/B	573839 54572932	575200	575219 572289
ENFIELD					
(16)	All Models except 12 volt	53432B	573839	575200	575219
(17)	'Interceptor' (12 volt)	53454B	573839	575200	575219
FRANCIS-BARNETT					
(18)	'Falcon' and 'Cruiser'	53331A/B	526404	526406	133551
(19)	'Plover'				
(20)	'Sports Cruiser'				
JAMES					
(21)	'Cadet'				
(22)	'Captain', 'Sports Captain', 'Sports Superswift' and Scooter				
NORTON					
(23)	'Jubilee' and 'Navigator'	53432B	573839	575200	575219
(24)	397 c.c. 'Electra'	53973A/B	54572932		572289
(25)	B8SS and 650SS 'Dominator'	53454B	573839	575200	575219
(26)	'Manxman' and 'Atlas'	53973A/B	54572932		572289
PANTHER					
(27)	'Princess' Scooter (6 volt)	53394B	573839	575200	575219
(28)	35 and 45 Sports	53432B	573839	575200	575219
(29)	100 and 120	53432B	573839	575200	575219
TRIUMPH					
(30)	'Tigress' TS1 Scooter	53432B	573839	575200	575219
(31)	'Tigress' TW2 Scooter	‡53972A/B	54572932		572289
(32)	'Tigress' TW2S Scooter (12 volt)	53454B	573839	575200	575219
(33)	T20 and T20SH	53394B	573839	575200	575219
(34)	T20R and T20S	53394B	573839	575200	575219
(35)	3TA and 5TA	53432B	573839	575200	575219
(36)	T100 and T90	53432B	573839	575200	575219
(37)	TR6 and T120	53432B	573839	575200	575219
(38)	T100SC	53432B	573839	575200	575219
(39)	6T	53454D	573839	575200	575219

*Home
‡Export
§U.S.A.
§Optional
¶Tail and
number plate

STOP TAIL AND NUMBER PLATE LAMP

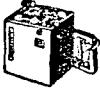

Battery

	136	137	138	139	140	141	142	143	144
	GASKET, LENS SEATING	BASE	GROMMET, BULB HOLDER	BULB HOLDER OR INTERIOR	SHELL, BULB HOLDER	CABLE GROMMET	NUT, LAMP FIXING	REFLEX REFLECTOR	BATTERY
									
(1)	575208	54573881	575207	*573828	575209	573825	166014		PUZ7E-11
(2)	575208 54571677	54573881 54571319	575207	*573828	575209 *54574348	573825	166014		MLZ9E
(3)	575208	575964	575207	*573828	575209	573825	166014		MKZ9E
(4)	54571677	54571319		*573828	*54574348				MKZ9E
(5)	575208	575964	575207	*573828	575209	573825	166014		MKZ9E
(6)	575208	54573881	575207	*573828	575209	573825	166014		MLZ9E
(7)									MLZ9E
(8)	575208 54571677	54573881 54571319	575207	*573828 *573828	575209 *54574348	573825	166014		MLZ9E
(9)	575208	575964	575207	*573828	575209	573825	166014		*MLZ9E
(10)									PUZ5E-11
(11)	575208 54571677	54573881 54571319	575207	*573828 *573828	575209 *54574348	573825	166014		MLZ9E
(12)	575208 575208	54573881 54571053	575207 575207	*573828 *573832	575209 54571021	573825 573825	166014 166014		
(13)	575208 54571677	54573881 54571319	575207	*573828 *573828	575209 *54574348	573825	166014		MLZ9E
(14)	575208 54571677	54573881 54571319	575207	*573828 *573828	575209 *54574348	573825	166014		MLZ9E
(15)	54571677	54571319		*573828	*54574348				
(16)	575208	54573881	575207	*573828	575209	573825	166014		MLZ9E
(17)	575208	575964	575207	*573828	575209	573825	166014		MLZ9E MKZ9E MLZ9E
(18)		526421		*573828			166103	57124A	MLZ9E
(19)									PUZ5E-10
(20)									MLZ9E
(21)									PUZ5E-10
(22)									MLZ9E
(23)	575208	54573881	575207	*573828	575209	573825	166014		
(24)	54571677	54571319		*573828	*54574348				
(25)	575208	575964	575207	573828	575209	573825	166014		MKZ9E
(26)	54571677	54571319		*573828	*54574348				MKZ9E
(27)	575208	54573881	575207	*573828	575209	573825	166014		MLZ9E
(28)	575208	54573881	575207	*573828	575209	573825	166014		PUZ5E-11
(29)	575208	54573881	575207	*573828	575209	573825	166014		PUZ7E-10
(30)									MLZ9E
(31)	575208 54571677	54573881 54571319	575207	*573828 *573828	575209 *54574348	573825	166014		MLZ9E
(32)	575208	575964	575207	*573828	575209	573825	166014		MLZ9E
(33)	575208	54573881	575207	*573828	575209	573825	166014		PUZ5E-11
(34)	575208	54573881	575207	*573828	575209	573825	166014		PUZ5E-11
(35)	575208	54573881	575207	*573828	575209	573825	166014		PUZ7E-11
(36)	575208	54573881	575207	*573828	575209	573825	166014		MLZ9E
(37)	575208	54573881	575207	*573828	575209	573825	166014		MLZ9E
(38)	575208	54573881	575207	*573828	575209	573825	166014		MLZ9E
(39)	575208	575964	575207	*573828	575209	573825	166014		MKZ9E
				*Interior only	*Bulb holder with reflector				*2 off †Turbo Twin*

PILOT LAMP AND PARTS

1964







SPECIFICATIONS

		145	146	147
		LAMP	NUT OR SCREW, LENS OR RIM FIXING	LENS
MAKE AND MODEL				
(1)	ARIEL 'Leader'	*53733D	526567	535901
(2)	ENFIELD All Models except 12 volt	52234A		573615
(3)	'Interceptor' (12 volt)	52414A		573615
		*Flasher		

BULBS





1964

SPECIFICATIONS

		148	149	150	151	152	153	154
		MAIN BEAM			PILOT	STOP TAIL AND NUMBER PLATE	PILOT LAMP	AMMET... OR WARNING LIGHT
		VERTICAL DIP	DIP LEFT	EXPORT EUROPE (except France)				
MAKE AND MODEL								
A.M.C. (A.J.S. and MATCHLESS)								
(1)	A.J.S. 16, 18 and 18CS; Matchless G3, G80 and G80CS	312		403	988	384		
(2)	A.J.S. 31CSR and 31; Matchless G12CSR, G12 and G15CS	446		370	989	380		
ARIEL								
(3)	'Arrow' and 'Leader'	312		377	988	352	*317	990
B.S.A.								
(4)	B2 ('Sunbeam' Scooter, 6 volt)	312		377	988	384		998
(5)	B2 ('Sunbeam' Scooter, 12 volt)	425		350	989	380		987
(6)	C15, SS80, B40 'Star' and B40SS90	312		377	988	352 *384		
(7)	C15T and C15S	166				384 †205		
(8)	A50 and A65 'Star'	312	373	403	988	†384 352		
(9)	A65R 'Rocket' and A65 'Lightning Rocket'	312			988	384		
(10)	A50 'Cyclone' and A65 'Spitfire-Hornet'	166				384		
ENFIELD								
(11)	All Models except 12 volt	312		403	988	384	988	
(12)	'Interceptor' (12 volt)	446			989	380	989	
FRANCIS BARNETT								
(13)	'Falcon' and 'Cruiser'					352		
NORTON								
(14)	885S and 650SS 'Dominator', 'Electra', 'Manxman' and 'Atlas'	446		350	989	380		
(15)	'Jubilee' and 'Navigator'					384		
PANTHER								
(16)	'Princess' Scooter (6 volt)	312			988	352		
(17)	35 and 45 Sports, 100 and 120	312			988	384		
TRIUMPH								
(18)	TW2 'Tigress' (6 volt)	312		377	988	384		998
(19)	TW2S 'Tigress' (12 volt)	425		350	989	380		987
(20)	T20	312		377	988	352		
(21)	T20R and T20S	166				352		
(22)	3TA and 3TA	312	373	403	988	384		
(23)	TR6, T100, T120 and T90	312			988	384		
(24)	T100SC	166				384		
(25)	T20SH	166			988	352		
(26)	6T	446		350	989	380		
						*B40 and U.S.A. †U.S.A.	*Flasher ('Leader')	

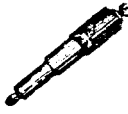
GIRLING EQUIPMENT

1964 SPECIFICATIONS

MAKE AND MODEL		155	156	157	158
		SUSPENSION UNIT	FERRULE BUSH AND TUBE ASSEMBLY	SPRING	OUTER DIRT SHIELD
					
A.J.S.					
(1)	350 c.c. 16 and 16C	64054493 (SB4)	9054/316A	9054/70	9054/151A
(2)	500 c.c. 18	64054493 (SB4)	9054/316A	9054/70	9054/151A
(3)	650 c.c. 31	64054493 (SB4)	9054/316A	9054/70	9054/151A
(4)	500 c.c. 18CS	64054392 (SB4)	9054/316A (top) 9054/316N (bottom)	9054/280	9054/295
(5)	650 c.c. 31CSR	64054493 (SB4)	9054/316A	9054/70	9054/151A
B.S.A.					
(6)	175 c.c. D7 'Bantam' and 125 c.c. DI	64053983 (SC3)	9054/316A (top) 9054/319V (bottom)		
(7)	175 c.c. and 250 c.c. 'Sunbeam' Scooter	64053950 (SB4)	9054/316A	64540471	
(8)	250 c.c. C15	64053973 (SC2.6)			
(9)	250 c.c. C15 Sports, C15T and C15S	64054445 (SB3)	9054/316A (top) 9054/316J (bottom)	9054/58	9054/47
(10)	350 c.c. B40	64054405 (SC3)			
(11)	350 c.c. B40SS90	64054445 (SB3)	9054/316A (top) 9054/316J (bottom)	9054/58	9054/47
(12)	500 c.c. A50 and 650 c.c. A65	64054394 (SB4)	9054/316A	9054/88	9054/150A
ENFIELD					
(13)	250 c.c. 'Turbo Twin'	64053811 (SB3)	9054/316H	9054/277	9054/152S
(14)	'Crusader Sports'	6404502 (SB3)	9054/316H	9054/312	9054/47
(15)	350 c.c. 'Bullet'	SB3/227Z	9054/316H	9054/277	9054/152Z
(16)	736 c.c. 'Interceptor'	64054604 (SB3)			
FRANCIS-BARNETT					
(17)	150 c.c. 'Plover'	D3/201B	9054/316A		
(18)	150 c.c. 'Fulmar' and 'Sports Fulmar'	64054402 (D4) (front only)	9054/316G		
(19)	200 c.c. 'Falcon'	SB3/235AB	9054/316L	9054/58	9054/151AB
(20)	250 c.c. 'Cruiser'	64054060 (SB3)	9054/316L	9054/58	9054/151AB
JAMES					
(21)	Scooter (front)	64054331 (D4)	9054/316N		
(22)	Scooter (rear)	64054266 (SC3.8)	9054/316N (top) 9054/316J (bottom)		
(23)	98 c.c. 'Comet' and 149 c.c. 'Cadet'	D3/201	9054/316A		
(24)	199 c.c. 'Captain' and 'Sports Captain'	64054198 (SC3.8)	9054/316L		
(25)	249 c.c. 'Sports Superswift'	64054258 (SC3.8)	9054/316J		
(26)	250 c.c. 'Commando' and 'Cotswold'	SB4/253AD	9054/316L	9054/58	9054/151AD
MATCHLESS					
(27)	350 c.c. G3 and G3C	64054493 (SB4)	9054/316A	9054/70	9054/151A
(28)	500 c.c. G80	64054493 (SB4)	9054/316A	9054/70	9054/151A
(29)	650 c.c. G12	64054493 (SB4)	9054/316A	9054/70	9054/151A
(30)	500 c.c. G80CS	64054392 (SB4)	9054/316A (top) 9054/316N (bottom)	9054/277	9054/151A
(31)	650 c.c. G12CSR	64054493 (SB4)	9054/316A	9054/70	9054/151A
(32)	750 c.c. G15CS	64054590 (SB4)			
NORTON					
(33)	250 c.c. 'Jubilee' and 400 c.c. 'Electra'	64053939 (SB3)	9054/316L	9054/58	9054/151A
(34)	350 c.c. 'Navigator'	64054359 (SB3)	9054/316L	9054/58	9054/151AV
(35)	'Dominator' Models, 'Manxman' and 'Atlas'	64054423 (SB3)			9054/151A
TRIUMPH					
(36)	175 c.c. and 250 c.c. 'Tigress' Scooter	64053950 (SB4)	9054/316A	64540471	
(37)	200 c.c. T20, T20R, T20S and T20SH	SC3/204	9054/316A (top) 9054/316J (bottom)		
(38)	350 c.c. 3TA 'Twenty-one'	64053946 (SB3)	9054/316A	64539963	9054/151A
(39)	500 c.c. 5TA 'Speed Twin'	64054200 (SB3)	9054/316A	64539963	9054/151A
(40)	350 c.c. T90 and 500 c.c. T100 'Tiger'	64053946 (SB3)	9054/316A	64539963	9054/151A
(41)	500 c.c. T100SC, 650 c.c. 6T, TR6 and T120	64054164 (SB4)	9054/316A	9054/280	9054/151A

MODELS 1964

A.J.S.

- 350 c.c., O.H.V., single cylinder, Model 16 'Sceptre'.
- 350 c.c., O.H.V., single cylinder, Model 16C 'Experts'.
- 500 c.c., O.H.V., single cylinder, Model 18 'Statesman'.
- 500 c.c., O.H.V., single cylinder, Model 18CS 'Southerner'.
- 650 c.c., O.H.V., twin cylinder, Model 31 'Swift'.
- 650 c.c., O.H.V., twin cylinder, Model 31CSR 'Hurricane'.

In the body of the catalogue, the term 'Competition Models' indicates machines as above bearing the model suffix letters C, CS and CSR.

ARIEL

- 250 c.c., two-stroke, twin cylinder, 'Leader'.
- 250 c.c., two-stroke, twin cylinder, 'Arrow' and 'Super Sports'.

B.S.A.

- 125 c.c., two-stroke, single cylinder, Model D1 'Bantam'.
- 175 c.c., two-stroke, single cylinder, Model D7 'Super Bantam'.
- 175 c.c., two-stroke, single cylinder, Model B1 'Sunbeam' Scooter.
- 250 c.c., O.H.V., twin cylinder, Model B2 'Sunbeam' Scooter (6 volt).
- 250 c.c., O.H.V., twin cylinder, Model B2S 'Sunbeam' Scooter (12 volt).
- 250 c.c., O.H.V., single cylinder, Model C15 'Star'.
- 250 c.c., O.H.V., single cylinder, Model C15S and C15T Competition.
- 250 c.c., O.H.V., single cylinder, Model C15SS80 'Sports Star'.
- 350 c.c., O.H.V., single cylinder, Model B40 'Star'.
- 350 c.c., O.H.V., single cylinder, Model B40SS90 'Sports Star'.
- 500 c.c., O.H.V., twin cylinder, Model A50 'Star'.
- 500 c.c., O.H.V., twin cylinder, Model A50 'Cyclone' (E.T. condition).
- 650 c.c., O.H.V., twin cylinder, Model A65 'Star'.
- 650 c.c., O.H.V., twin cylinder, Model A65R 'Rocket'.
- 650 c.c., O.H.V., twin cylinder, Model A65 'Lightning Rocket'.
- 650 c.c., O.H.V., twin cylinder, Model A65 'Spitfire-Hornet' (E.T. condition).

ENFIELD

- 250 c.c., O.H.V., single cylinder, 'Continental'.
- 250 c.c., O.H.V., single cylinder, 'Clipper'.
- 250 c.c., O.H.V., single cylinder, 'Crusader Sports'.
- 250 c.c., two-stroke, twin cylinder, 'Turbo Twin'.
- 350 c.c., O.H.V., single cylinder, 'Bullet'.
- 736 c.c., O.H.V., twin cylinder, 'Interceptor' (6 volt and 12 volt).

FRANCIS-BARNETT

- 150 c.c., two-stroke, single cylinder, Model 95 'Plover'.
- 150 c.c., two-stroke, single cylinder, Model 88 'Fulmar'.
- 150 c.c., two-stroke, single cylinder, Model 90 'Sports Fulmar'.
- 200 c.c., two-stroke, single cylinder, Model 87 'Falcon'.
- 250 c.c., two-stroke, twin cylinder, Model 89 'Cruiser'.
- 250 c.c., two-stroke, twin cylinder, Model 91 'Sports Cruiser'.
- 250 c.c., two-stroke, single cylinder, Model 92 'Trials'.
- 250 c.c., two-stroke, single cylinder, Model 93 'Scrambler'.

JAMES

- 98 c.c., two-stroke, single cylinder, Model L1 'Comet'.
- 150 c.c., two-stroke, single cylinder, Model M15 'Cadet'.
- 150 c.c., two-stroke, single cylinder, Model SC4 Scooter.
- 200 c.c., two-stroke, single cylinder, Model L20 'Captain'.
- 200 c.c., two-stroke, single cylinder, Model L20S 'Sports Captain'.
- 250 c.c., two-stroke, single cylinder, Model M25R 'Cotswold'.
- 250 c.c., two-stroke, twin cylinder, Model M25S 'Sports Super Swift'.
- 250 c.c., two-stroke, single cylinder, Model 25T 'Commando'.

MATCHLESS

- 350 c.c., O.H.V., single cylinder, Model G3 'Mercury'.
- 350 c.c., O.H.V., single cylinder, Model G3C 'Maestro'.
- 500 c.c., O.H.V., single cylinder, Model G80 'Major'.
- 500 c.c., O.H.V., single cylinder, Model G80CS 'Marksman'.
- 650 c.c., O.H.V., twin cylinder, Model G12 'Majestic'.
- 650 c.c., O.H.V., twin cylinder, Model G12CSR 'Monarch'.
- 750 c.c., O.H.V., twin cylinder, Model G15CS.

NORTON

- 250 c.c., O.H.V., twin cylinder, 'Jubilee'.
- 349 c.c., O.H.V., twin cylinder, 'Navigator'.
- 400 c.c., O.H.V., twin cylinder, 'Electra'.
- 497 c.c., O.H.V., twin cylinder, Model 88SS 'Dominator'.
- 650 c.c., O.H.V., twin cylinder, Model 650SS 'Dominator'.
- 650 c.c., O.H.V., twin cylinder, 'Manxman' (U.S.A. only).
- 745 c.c., O.H.V., twin cylinder, 'Atlas'.

PANTHER

- 175 c.c., two-stroke, single cylinder, 'Princess' Scooter.
- 250 c.c., two-stroke, twin cylinder, Model 35.
- 324 c.c., two-stroke, twin cylinder, Model 45.
- 590 c.c., O.H.V., single cylinder, Model 100 De Luxe.
- 645 c.c., O.H.V., single cylinder, Model 120.

TRIUMPH

- 173 c.c., two-stroke, single cylinder, Model T51 'Tigress' Scooter.
- 200 c.c., O.H.V., single cylinder, Model T20 'Tiger Cub'.
- 200 c.c., O.H.V., single cylinder, Model T20R 'Trials' and T20S 'Scrambler'.
- 200 c.c., O.H.V., single cylinder, Model T20SH 'Sports Cub'.
- 250 c.c., O.H.V., twin cylinder, Model TW2 'Tigress' Scooter (6 volt).
- 250 c.c., O.H.V., twin cylinder, Model TW2S 'Tigress' Scooter (12 volt).
- 350 c.c., O.H.V., twin cylinder, Model 3TA 'Twenty-one'.
- 350 c.c., O.H.V., twin cylinder, Model T90 'Tiger'.
- 500 c.c., O.H.V., twin cylinder, Model 5TA 'Speed Twin'.
- 500 c.c., O.H.V., twin cylinder, Model T100SC 'Tiger'.
- 500 c.c., O.H.V., twin cylinder, Model T100 'Tiger'.
- 650 c.c., O.H.V., twin cylinder, Model TR6 'Trophy'.
- 650 c.c., O.H.V., twin cylinder, Model T120 'Bonneville'.
- 650 c.c., O.H.V., twin cylinder, Model 6T 'Thunderbird'.