



DISMANTLING AND REBUILDING FULL-WIDTH FRONT WHEEL HUBS

THE wheels are carried on adjustable, taper roller bearings. The bearing cups are a press fit in the spindle tunnel; the left-hand side bearing is located in the hub by a circlip lying in a groove at the end of the tunnel, and the right-hand bearing is adjustable for position. It is moved axially by a screwed sleeve which is threaded into the right-hand end of the spindle tunnel, and is locked into position by a circular nut.

A special feature of the assembly is that bearings do not have a separate inner tapered cone, but make direct contact on the hardened wheel spindle. Therefore, when wear eventually occurs, and replacement becomes necessary, the spindle, taper rollers, cages and outer cups must all be renewed. Replacement spindles are sold complete with bearings.

Special Tools

To deal with the circular locking nut and the screwed adjusting sleeve, special spanners are required. These are a hook-spanner for the lock nut, part No. 010438; spanner for the adjusting sleeve, part No. B3334. They can be obtained from the Service Department.

Dismantling

The numbers shown thus: (2), refer to the numbered parts in the illustration.

As a preliminary remove the wheel from the forks, and take off from the spindle the nut (14) and the washer (13).

- (a) Slacken and remove the nut (12) which is spigotted into the brake-cover plate and secures it on the spindle.

It may be necessary to replace the spindle nut (14) on the spindle end and hold it with a spanner while the nut (12) is being slackened.

- (b) Withdraw the brake-cover plate complete with brake shoes from the hub.
- (c) Remove the nut (11), which lies on the inner side of the brake-cover plate.
- (d) Remove the circular lock nut (10) and the adjusting sleeve (9) from the right-hand side of the hub. With them will come the hub cover disc.

Removal of the Bearings

It is important that the bearing parts are not mixed. The bearing cups, if being refitted, must always be replaced on the same side of the hub.

- (e) To facilitate removal of the bearing cups, gently heat the hub shell.
- (f) Place on the spindle end (brake side) a rod of copper or brass, slightly less in diameter than the spindle, and apply pressure so that the oil-seal cup washer (8), oil seal (7), oil-seal retaining washer (6) and bearing cup (5) are ejected.
- (g) Withdraw the spindle complete with the two sets of caged taper rollers.

NOTE If a press is not available this operation can be performed by jarring the soft metal rod with a hammer.

Whichever method is used the utmost care must be taken otherwise the bearings or hub shell may be damaged.

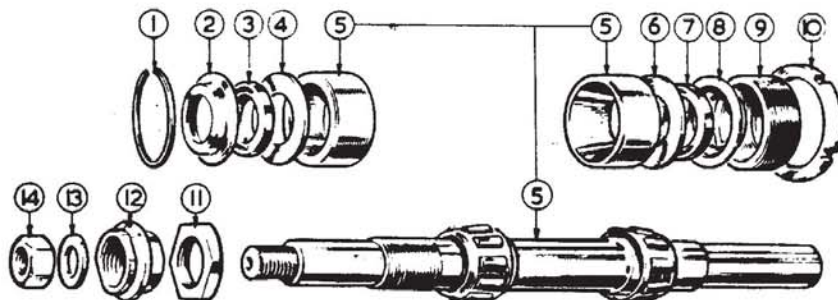

MAINTENANCE INSTRUCTIONS

No. 505



Sheet 2

Refitting the Brake-Cover Plate

It is important that the brake-cover plate is correctly positioned. It is located on the spindle axially by the nut (11), and secured in position by the spigot nut (12), but the correct axial location is obtained by trial. Proceed as follows.

- (l) Refit the nut (11). The bevelled face must be remote from the brake-cover plate.
- (m) Push the brake-cover plate into the brake drum. The rim of the plate must go into the hub shell, and the outside face must be flush with the hub shell edge (see illustration below).
If it does not, withdraw the cover plate, and reposition the nut (11) until the correct position is obtained. When this is correct refit the nut (12), it slides into the brake-cover plate, but do not tighten.
- (n) Before the nut (12) is tightened and the brake-cover plate locked into position the brake shoes must be centralized. This is accomplished by expanding the

brake shoes. Operate the brake lever until the shoes make contact with the brake drum, and hold in this position until the nut (12) has been tightened, and so clamped the brake-cover into position.

It may be necessary to thread a short length of tube over the brake operating lever to obtain sufficient leverage to hold it operated with ease.

When the plate is clamped the operating lever can be released.

Before completing the assembly of the hub the bearings must be adjusted. See *Maintenance Instruction No. 502*.

- (o) After adjusting the bearings and before tightening the circular lock nut (10), the hub cover disc must be placed in the correct position, that is, the hole in the disc face must be in line with the grease nipple located in the hub shell so that a grease gun nozzle can be inserted through the hole, and engage with the nipple. When the correct position has been found, tighten the lock nut (10).

Section through part of hub showing spindle, locating and securing nuts.

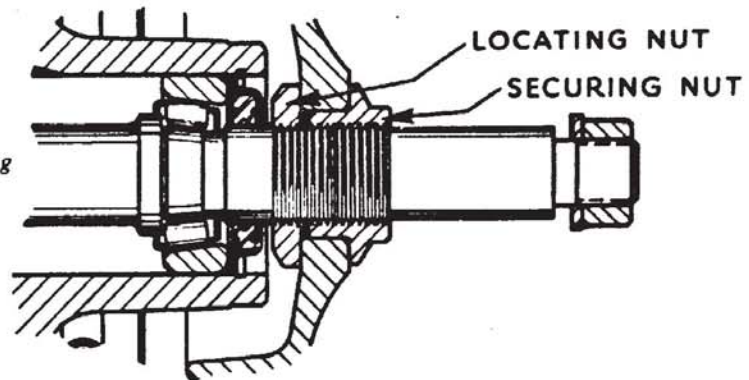

Section through part of hub showing how the brake-cover plate is placed inside the hub, and that the rim is flush with the hub shell edge.

