

**DRIVING & ADJUSTMENT  
INSTRUCTIONS**

**MODELS**

**35 4**

**35 12**

**35 16**

**35 14**

**35 22**

**35 26**

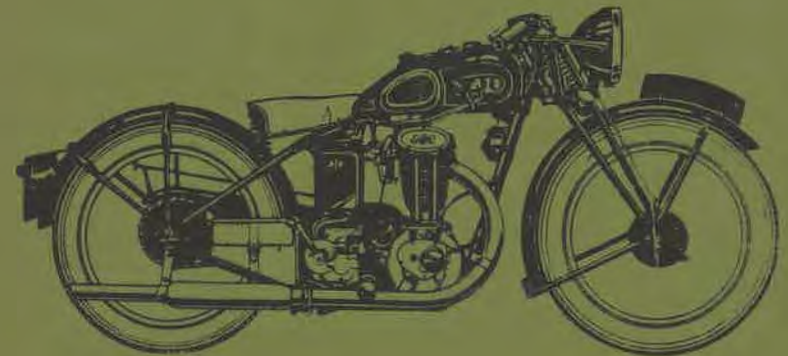

---

**MOTOR A.J.S. CYCLES**

*Manufacturers,*

**44-45, Plumstead Rd., Plumstead,  
London, S.E.18, England**

## INTRODUCTION.

### A Personal Message to all A.J.S. Owners.

---

It is our desire that you obtain from your A.J.S. the service, comfort, enjoyment and innumerable miles of low-cost travel that we have earnestly endeavoured to build into it.

A motor cycle, it must be remembered, is a highly specialised piece of engineering, and while it does not call for great engineering skill in driving, the exercise of a little mechanical sense, and the occasional use of a spanner, cleaning cloth, etc., is very necessary if the maximum service is to be obtained with the requisite degree of satisfaction. In the following pages we give, without going into intricate technical detail, much valuable information that you should have, in order to give your cycle the careful attention which it merits.

Neglect to make necessary adjustment, or only casual attention to the lubrication of important parts, will soon neutralise the best efforts of the designers who have whole-heartedly devoted their skill and knowledge to the production of your cycle, and may bring needless trouble and expense to you, its owner.

A.J.S. MOTOR CYCLES.

# GENERAL INFORMATION.

## TAKING OVER A NEW MACHINE.

Having filled up with petrol and oil of one of the brands specially recommended (see Lubrication), it is advisable before starting the engine to sit over the cycle and memorise the various controls. Neutral position of the gears must always be obtained before starting up. This neutral position is the first one forward of the extreme rear-most or low-gear position. The ignition is advanced or retarded by means of the small lower lever on the left handlebar. The throttle control is operated by a twist-grip on the right handlebar, while the  $\mu$  is controlled by means of a small lever on the same side. The valve-lifter and clutch controls are fixed to the left side bar, and the front brake control to the right bar. All controls advance or open by an inward movement of the various levers. For starting from cold, the ignition should be about half advanced, the throttle very slightly open only, and the air completely closed. The petrol is turned on by pressing inward the end of the tap sliding plunger marked "On." The ignition is switched on by turning the panel switch to the position marked "C" (coil ignition models only), or to "H" or "L" for night riding. On these coil ignition Models 35/4, 35/12 and 35/16, a red light will be observed through the small window on the panel top when the switch is at any of the above positions and the engine idle. The object of this red light is to indicate that current is flowing to the ignition coil, and unless the switch is turned to the "Off" position for daylight, or the "PK" position at night-time if parking lights are required with the engine idle, a quickly run-down battery will result. The red light which, incidentally, only shows when the contact points are together must, therefore, be regarded as a warning indicator and is in actual fact provided for that purpose. A separate dipping switch ring is fitted to the left handle grip to enable the head light to be dipped instantly, as and when required. Assuming that all the controls have been set as described, to start the engine first flood the carburettor until petrol actually overflows from the vent hole, then with the valve-lifter raised and ignition switched off, turn the engine over a few times in order to draw a charge of gas into the cylinder. Then switch on and give the kickstarter pedal a violent push downwards, releasing the valve-lifter lever when the pedal is nearly at the lowest position, when the impetus should be sufficient to carry the engine over at least one compression or firing stroke. If the engine does not start at the first attempt, repeat the last operation. As soon as the engine starts, close the throttle to check the speed, and while it is warming up, raise the oil tank filter cap in order to observe that oil is circulating (see notes on oiling system). After allowing the engine to idle for a moment or two to warm up, sit over the cycle and give a gentle push forward to release the prop stand. Then release the clutch by drawing inward to the fullest possible extent the lever on left handlebar and without delay, gently engage first gear, after

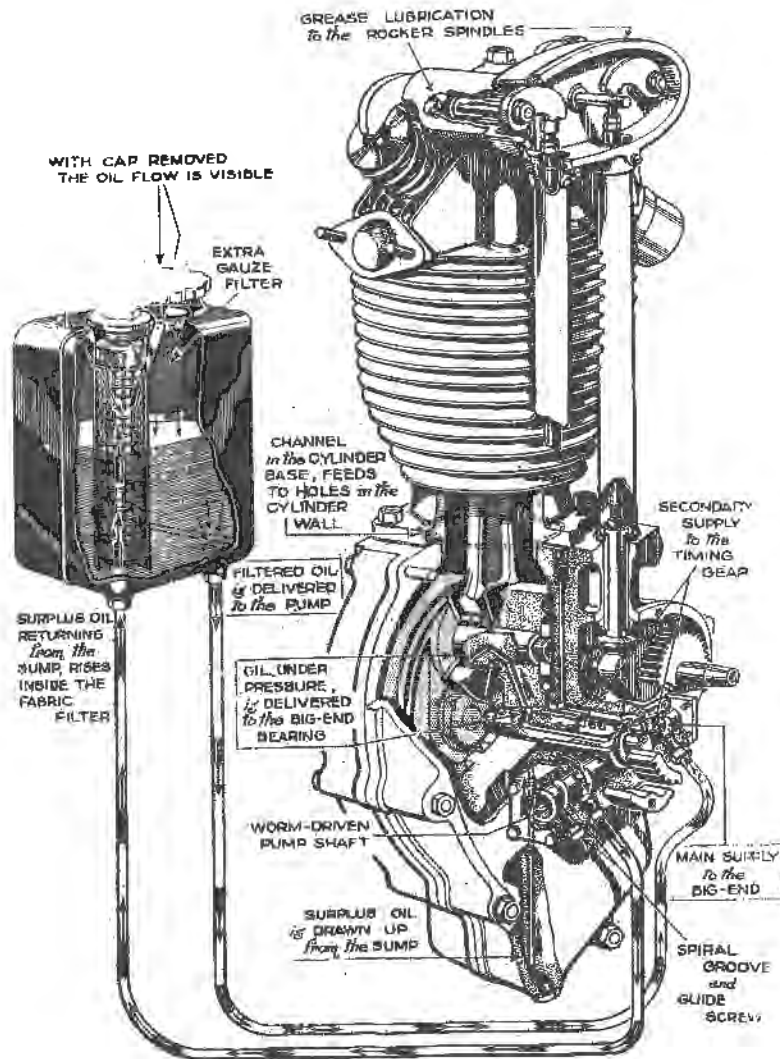

Engine Unit Showing Oiling System.

### Taking Over a New Machine—contd.

which slowly release pressure from the clutch lever, when the cycle will commence to move forward. When under way, again release the clutch and simultaneously shift the gear lever into second speed position, releasing the pressure on the clutch lever gently immediately the change of gear has been made. Repeat the movements until top gear is reached, and remember that for all changes of gear, whether up or down, the clutch must be released just a fractional part of a second prior to moving the gear lever. When in motion, it will be found sufficient to move the clutch lever only just sufficient to ease the drive and with reasonable care it will be found possible to make changes of gear without a sound.

### DRIVING.

In general driving, it is always advisable to advance the ignition as far as possible without causing knocking. When ascending a steep hill, as the engine slows, retard the ignition just sufficiently to prevent knocking, and if a change of gear then be made, the ignition should be again advanced, as the speed of the engine is increased by the use of the lower gear. For descending exceptionally steep and dangerous hills, the second gear may be engaged, enabling the frictional resistance of the engine to assist in retarding the descent. Under no circumstances, however, should the bottom gear be used for this purpose, as by so doing, an abnormal and unfair strain would be imposed upon the rear driving chain under certain circumstances.

It is advisable to ease the clutch slightly when rounding acute corners or when travelling slowly in top gear. If this practice is adopted from the first, much unnecessary gear changing will be avoided.

**IMPORTANT NOTE.**—On Models 35/12, 35/16, 35/22 and 35/26 the petrol tap should always be turned off immediately the engine is stationary after a run, as otherwise, owing to the downswept inlet port, there is a possibility of neat petrol entering the cylinder interior should the carburettor flood. Obviously, in addition to a risk of fire, there is a real danger of oil thinning and consequent engine seizure, if this simple precaution is not taken. Therefore, turn the petrol off after every run.

### "DON'TS" IN DRIVING.

- DO NOT rev the engine up immediately from cold, but allow the oil to circulate first.
- DO NOT race the engine unnecessarily, or let the clutch in sufficiently suddenly to cause the wheel to spin. Take a pride in a silent, smooth getaway.
- DO NOT use the brakes with violence. Brake early and drive on the throttle instead of the brakes.
- DO NOT allow engine to labour on high gear on a steep gradient and remember that an easier, faster, and better ascent can be made on the next lower gear.

### "Don'ts" in Driving—contd.

- DO NOT make a practice of starting on second speed.
- DO NOT under any circumstances, allow the chains to run very slack or very dry. Either will soon cause trouble, and adjustments are easy. Slack chains will inevitably cause harshness of transmission.
- DO NOT force the engine or drive above a maximum speed of 30 m.p.h. for the first 500 miles. Mention is made of this warning on account of the natural desire of a new owner to ascertain his mount's maximum capabilities. However, until all bearings are well run in, etc., it is advisable to refrain from speed bursts and the accompanying possibility of seized bearings, piston rings, etc. The first 500 miles of an engine's existence is far more important than the next 5,000.
- DO NOT race the engine in neutral gear position, violently accelerate from a standstill, or drive at full speed on open throttle, etc., when in a residential district. Any motor cycle (or, for that matter, any motor vehicle) when so driven creates abnormal noise, and in the interests of all motorists we earnestly implore every A.J.S. owner to studiously refrain from any of the practices enumerated, or any calculated to cause annoyance to the public in general. Recollect that the degree of silence of your cycle is judged not by the actual noise it is making, but by comparison with other noises present. For example, in a busy street your cycle might be inaudible, while in a quiet, narrow street of high buildings, it might be heard for several hundred yards, although in each case being driven in exactly the same manner.
- DO NOT forget to shut the petrol off, or to see that the red light in head lamp is not showing after a run (coil ignition models only).

## LUBRICATION.

### ENGINE.

Proper lubrication is of vital importance and the use of only the best of lubricants will be repaid many times over by long wear and good service. The following oils and greases are specially recommended:—

#### Engine:

(Summer) Patent Castrol N.X.L., Mobiloil D., or Aeroshell.  
(Winter) Patent Castrol N.L., Mobiloil D., or Aeroshell.

#### Gear Box:

Castrolase Medium, Mobilgrease No. 2, or Shell Motor Grease (soft).

## All Grease Gun Points:

Castrolase Medium, Mobilgrease No. 2, or Shell Motor Grease (soft).

Oil is carried in the tank underneath the saddle, and in use the level of oil in the tank should never be allowed to fall below the half-full mark. The integral oil pump is of the single-plunger double-diameter type, the larger diameter being used for exhausting the crankcase sump, and the smaller end for delivering oil to all the essential parts of the engine interior, from whence it drains into the sump to be returned to the tank. Provision is made to observe the oil in circulation and a practice should be made of checking this before each run. To do so, it is necessary to raise the oil tank filler cap while the engine is warming up, when the returning oil will be observed running from the small spout immediately underneath the cap. No provision is made for external adjustment of the oil supply, the correct delivery to each part being arranged internally by suitably dimensioned passages. It might here be explained that the oil is forced direct to the timing gear chamber which, after filing same to a pre-determined level, overflows into the flywheel chamber and so drains away to the sump. Oil is also forced into the timing gear side flywheel axle and thence through a drilled passage in the flywheel to the big end bearing, the splash from which passes up into the cylinder interior. In addition to this splash, the cylinder receives oil via a direct ball valve controlled oil passage, which ensures a very adequate supply under all conditions for this, the most vital part of the engine. No attention to the oiling system is required other than observing the return of oil to the tank prior to a run, and the continual replenishment of the supply tank, the level of oil in which, as mentioned above, must be above the half-full mark and must not be filled when engine is cold to a level higher than one inch below the return pipe outlet. (See Oil Circulation illustration.)

## NOTES ON THE OILING SYSTEM.

If the engine is for any reason dismantled, the crankcase must not on any account be separated until the pump plunger has been withdrawn. To withdraw this plunger, first remove both end caps and also the guide screw, when the plunger can be pushed out large end first. When re-assembling, the plunger must be inserted after the crankcase sections have been bolted together, and before re-fitting the end caps, the guide screw must be replaced, with its relieved tip engaging the profiled cam groove in the plunger. By moving the plunger to and fro while this screw is being introduced, the correct location of the groove can be easily felt and the screw in question must be finally firmly screwed home. The entire oiling system is simplicity itself, only one moving part being employed, viz., the double-diameter plunger. This plunger is rotated by the engine shaft and moves backwards and forwards while rotating, under the influence of the small guide screw which engages the profiled annular groove cut in the plunger end. As the plunger moves in its housing in one direction,

the large end draws oil from the sump, while at the same time the smaller end is delivering fresh oil to the various channels provided. Upon the reverse movement of the plunger, the large end returns to the tank the oil already drawn from the sump, while the smaller end draws a fresh charge of oil from the tank in readiness for delivery to the engine upon the following movement of the plunger. This action, of course, goes on all the while the engine is revolving, and since the exhausting end of the plunger is the larger, the engine sump is always kept clear of oil, hence the term "dry sump." At the same time, a large quantity of clean, cool oil is being forced, under pressure, to all working parts. A double system of filtering the oil is provided in the oil tank. The first consists of a gauze screen in the filler cap orifice to prevent the admission of fluff or foreign matter when replenishing, and the second consists of a felt cartridge through which the returning oil is compelled to pass before emerging from the spout immediately underneath the tank filler cap. This cartridge filter can be removed upon unscrewing the hexagonally-headed cap on the top of the oil tank. About once every 1,000 miles both filters should be removed and carefully washed in clean petrol, while once each season, or not less frequently than once every 5,000 miles, the entire tank should be removed, thoroughly washed out with petrol and after refitting, filled to the correct level with fresh, clean oil. To avoid undue waste, it is quite permissible to arrange for this clean-out when the oil is at the lowest recommended level, although it must be pointed out that, normally, it is highly desirable to add fresh oil frequently in small quantities in preference to allowing the supply to become almost exhausted before re-filling, the reason for this being that the more oil there is in the tank, the cooler it will keep in circulation.

## CHAINS.

The primary chain and the dynamo chain both run in an oil bath case and, provided that the oil level is correctly maintained, will require no attention other than occasional adjustment. The inspection cap orifice on the chain case determines the correct level and it is imperative that the level is not allowed to fall more than about 3/16 in. below the height of the bottom edge of this orifice. Failure to maintain this level will result in rapid chain wear and possibly destruction. It is, therefore, advisable to make a practice of verifying the level weekly. The case covering the magneto drive chain of the Models 35/14, 35/22 and 35/26 is packed with grease during assembly. This will be sufficient to last at least 5,000 miles, after which the cover should be removed and the case re-packed with fresh grease, and the opportunity taken to adjust the chain tension if necessary. The rear chain should be removed every 1,500 to 2,000 miles in summer and every 1,000 miles during winter and thoroughly washed in paraffin. After carefully wiping, it should then be immersed in a bath of molten tallow or, as a poorer substitute, ordinary engine oil. If the latter is used, the chain should be laid in soak over-night in order to ensure penetration to all link joints. If treated in this manner, at least 8,000 to 10,000 miles of satisfactory service should be obtained.

## GEAR BOX.

About once every 1,000 miles a small quantity of grease should be added, if necessary, via the aperture on the gear box top covered by an oval metal cap. This cap is slotted at one end to allow of it being twisted round to uncover the aperture. The gear box must not be entirely filled and under normal conditions the addition of about two ounces of grease every 1,000 miles will be found ample. WEEKLY inject a little grease at all grease gun points.

NOTE.—The greases recommended for gear box lubrication are supplied in collapsible tube containers with a suitable bent spout to facilitate injection into the gear box interior.

## HUBS.

Upon assembly, all hubs are tightly packed with grease. To prevent the entry of mud and water in use, a small additional quantity of grease should be injected by means of the grease gun via the nipples provided on each hub, about once every 500 miles.

## FORK SPINDLES.

To maintain efficient front fork action, adequate spindle lubrication is essential and an injection of grease via the various nipples provided, is recommended weekly, or at least once every 500 miles.

## DYNAMO LUBRICATION.

(Models 35/12, 35/16 and 35/4 only.)

Use oil very sparingly. A few drops of oil should be inserted through the lubricator on the driving end once every 500 miles, and a small quantity of grease should be pressed into the hole to be seen on the commutator end once every 1,000 miles. Avoid using too much grease or pressure, otherwise it may be forced through the bearing on to the commutator and cause trouble.

(Models 35/22, 35/26 and 35/14.)

Dynamo bearings on above models are packed with grease before leaving the works and lubricators are not, therefore, provided. After the motor cycle has run several thousand miles, the dynamo should be dismantled for cleaning, adjustment and re-packing the bearings with grease. This is carried out preferably at the nearest Lucas Service Depot.

## BOWDEN CABLES.

To lubricate Bowden inner cables has hitherto meant the entire removal of the cable, unsoldering one end nipple, etc., altogether a difficult and expensive job and one, consequently, usually neglected. By means of a specially designed oil gun, it is now possible to flood the inner wire with lubricant in a few seconds, and we can only state that the effect of this on a dry cable has to be tried to be believed. Oil is injected through a small bared patch on the outer casing and is forced through the spiral casing on to and along the inner wire. All

## Bowden Cables—contd.

Bowden cables are fitted with small metal clips, which will be observed approximately at the centre of each. These clips cover the small bared patch referred to above, and to apply the gun, it is only necessary to slide the clip along the casing to enable the specially constructed gun to be clamped, with the bared patch occupying a central position on the rubber pad on the gun nozzle. A few turns of the screwed plunger is then all that is required to efficiently flood the entire length of the cable with lubricant. The cost of this special gun is 5s. 9d. and we recommend every owner to have one in his home tool kit.

# ADJUSTMENTS & MAINTENANCE.

## DECARBONISATION.

The period for which an engine will run satisfactorily without being decarbonised depends to a great extent upon driving conditions. Generally, however, this process should be carried out every 1,500 to 2,000 miles. The need for decarbonising will be indicated by a tendency to pink or knock when ascending hills, or upon accelerating after rounding a corner, and particularly so when the engine is hot. Although to remove carbon deposit it is only necessary to take off the cylinder head, it is advisable to remove the cylinder each 5,000 miles in order to also inspect the piston rings and remove any deposit from the grooves in which they operate.

## TO REMOVE CYLINDER HEAD.

(Models 35/4 and 35/14.)

First remove the sparking plug to avoid damage, then remove, in turn, all the cylinder head fixing bolts, when the head can be lifted off. Carefully remove the "C" and "A" gasket and place it somewhere safe until it is required for re-assembly. Then with a suitable instrument (an old pen-knife will do) gently remove all carbon deposit from the cylinder head interior and also from the top of piston, after which wipe away all traces of carbon chips with a piece of calico, and with the piston at the bottom of its stroke, smear the cylinder walls with a thin coating of clean engine oil, wiping away any surplus observed upon bringing the piston again to the top of its stroke. The gasket should then be carefully wiped and placed in position on the cylinder, after which the head may be applied and all fixing bolts re-inserted. Before inserting these bolts, it is a good tip to coat the threaded ends with a thin layer of graphite grease. This will greatly facilitate their removal next time decarbonisation is necessary. Care must be exercised to ensure even tightening of all the head fixing bolts. It is advised to screw them all down lightly and then go round the head one bolt at a time, tightening only about one quarter of a turn until all are firmly and evenly tight. Do not under any circum-

### To Remove Cylinder Head (Models 35/4 and 35/14)—contd.

stances completely tighten down one bolt while the others are still loose. After re-ntting the sparking plug start up the engine and after allowing it to idle for several moments to warm up, go over each cylinder head bolt again, when slight further tightening will be found possible.

### TO REMOVE CYLINDER HEAD ON O.H.V. MODELS.

First remove exhaust system, petrol pipe and sparking plug. Then unscrew the cap on the carburettor mixing chamber and gently withdraw the throttle and air slides. Next remove all four tank fixing bolts and raise the tank on a wooden block placed across each support bar and in a position as high as possible, to allow access to the cylinder head bolts, etc. (Note: This is not necessary on Models 35/12 and 35/22.) Next detach the cylinder head stay, and to facilitate correct re-assembly, note carefully how this stay is attached. Next unscrew the four rocker box fixing bolts, when the entire rocker box, together with push rods and tubes can be removed. It is now only necessary to unscrew the four cylinder head fixing bolts, when the head can be lifted off. It will be observed that a plain soft copper cylinder head gasket is used for the head joint, and upon removal, every care must be exercised to avoid damage. In the event of any signs of leakage being observed, the gasket should be annealed prior to the re-assembly. This is done by heating to a dull red heat and suddenly plunging in cold water. No jointing mixture or compound of any description is recommended. During the removal and re-fixing process, care must be taken to avoid losing the small hardened steel valve caps, and should the valves be removed for grinding-in purposes, they should not be interchanged. After carefully removing all carbon deposit from both piston top and cylinder head, the interior of cylinder should be carefully wiped out with a clean calico rag and smeared with fresh engine oil. In re-assembling, all cylinder head fixing bolts must be uniformly tightened, and the best method to ensure this is to tighten down finger-tight only and then go over each bolt in turn, giving a little extra pressure. Before replacing the rocker box, first remove the cover plate so as to be able to see that the O.H. rocker ends properly enter the cupped push rod ends, and to facilitate matters revolve the engine until both tappets are down.

### TO GRIND IN VALVES.

In the case of O.H.V. models, valve grinding is advised upon each occasion when decarbonisation is undertaken. After the cylinder head has been removed as described, to remove valves it will be found convenient to rest the head of each in turn on a small block (wood preferably) while the spring is being compressed to allow of the removal of the taper valve cap divided collar. It may be necessary to give the valve spring cap a sharp tap to release this taper collar. After removing all carbon deposit, the face of each valve seating should be smeared with a good grinding paste (this may be obtained already mixed) and the valve revolved slightly backwards and forwards (never

### To Grind In Valves—contd.

revolve completely) while light pressure is applied to the head. During this operation, it is advisable to occasionally raise the valve on its seating and turn in the guide slightly, afterwards repeating the backwards and forwards movement.

Generally, one application of grinding paste will be ample for the inlet, but two or three applications may be necessary to entirely restore the exhaust valve seating. After this grinding-in has been satisfactorily accomplished, all traces of the grinding-in mixture should be carefully washed off with petrol, and both valve stems and guides cleaned thoroughly. Prior to re-fitting, it is advisable to smear each valve stem with graphite grease.

A special tool for compressing valve springs can be supplied at 6s. 6d. (Part Number TTK 8).

A small clamp tommy wrench, to facilitate valve grinding, can also be supplied at a cost of sixpence.

For S.V. models, valve grinding during alternative decarbonisation is sufficient and care is necessary as with O.H.V. models to avoid interchanging the two valves. Tappet and rocker clearances must always be checked after cylinder head removal, and the correct adjustment obtained. See instructions below.

### TO ADJUST VALVE TAPPETS ON S.V. MODELS.

Remove valve spring cover, and with the spanner provided in tool kit, hold the tappet and slack off the lock nut securing the adjustable tappet head. Then screw the head up or down as may be required, to obtain the correct clearance, after which securely tighten the locking nut. The correct clearances are .006 for the inlet and .006 for the exhaust.

NOTE.—Tappet clearances should be tested while the engine is warm, not hot.

### TO ADJUST VALVE TAPPETS ON O.H.V. MODELS.

First remove the rocker box cover secured with three screws, this will expose the adjustable ends of the valve push rods. Next revolve the engine until the valve which requires adjustment is open, and with the spanners provided in the tool kit, loosen the lock nut securing the adjustable rod end. Then revolve the engine until the valve is completely closed and unscrew the adjustable push rod end until the correct clearance is obtained, after which once more revolve the engine until the valve is fully open, and taking care not to disturb the adjustment obtained, carefully secure the lock nut. Always make a point of checking the adjustment obtained after the lock nut has been re-tightened.

NOTE.—The correct clearance between the rocker ends and the valve ends when valves are completely closed and the engine cold is the nearest approach to nil possible. It should be observed that the hardened steel valve end caps are free to be revolved with the fingers while at the same time no perceptible up and down movement of the rocker is possible.

## VALVE TIMING.

The timing gears are marked for re-setting purposes, and the correct opening of the valves is as follows: The inlet commences to open 20 degrees, or  $7/64$ in. before top of exhaust scavenging stroke, and closes 67 degrees, or  $25/32$ in. up the compression stroke. Exhaust valve commences to open 75 degrees, or  $31/32$ in. from bottom of firing stroke, and closes 28 degrees, or  $7/32$ in. down induction stroke. To test valve timing, the tappets must first be set to .014in. clearance. See instruction above for normal running clearances.

## IGNITION SETTING.

The correct ignition setting for Models 35/12 and 35/16 is  $5/16$ in. B.T.D.C.; for Model 35/4  $1/4$ in. B.T.D.C., for Models 35/22 and 35/26  $7/16$ in. B.T.D.C., and for Model 35/14  $1/2$ in. B.T.D.C., in every case with the ignition fully advanced.

### TO RE-TIME IGNITION ON MODELS 35/12, 35/16 AND 35/4.

Remove the bakelite contact breaker cap and slacken the screw securing the contact breaker cam. Then with a small punch operating in one of the slots in this cam, give a sharp but light tap. This will loosen the cam on the taper end of the shaft to which it is fitted. Now set the piston and the ignition lever in the position mentioned above, after which gently turn the cam with the fingers in an anti-clockwise direction until the contact points are just about to part, in which position carefully re-tighten the cam fixing screw and replace the bakelite cap. It is essential, in this ignition setting operation, to obtain exactly the prescribed piston setting on the compression stroke, i.e., the stroke at the top of which both valves are closed.

NOTE.—Check contact breaker gap before setting timing (.018 to .020).

### TO RE-TIME IGNITION ON MODELS 35/22, 35/26 AND 35/14.

Remove the outer portion of aluminium magneto chain cover and slack off the nut securing the lower sprocket. Then, with a stout screwdriver, or the hooked end of a stout tyre lever, gently lever the sprocket loose from the taper on the camshaft to which it is attached. Then carefully turn the engine until the piston is at the exact position described above (according to model), observing that it is on the stroke at which both valves are closed. Now fully advance the ignition and remove the contact breaker cap, after which gently turn the magneto with the fingers in its ordinary direction (i.e., contra-clockwise when looking at the sprocket end) until the contact points are just about to break, in which position the sprocket fixing nut must be carefully re-tightened. Needless to add, it is of vital importance to correctly obtain the prescribed piston position and to secure the chain sprocket at the exact position at which the contact points commence to part. To find the exact point of break, place a piece of cigarette paper between the points and turn the magneto armature until the paper is just released, and no more, upon a gentle pull.

## TO ADJUST THE DYNAMO CHAIN (ALL MODELS).

Adjustment is arranged by revolving the dynamo unit in its cradle mounting, and the correct adjustment should permit a movement of about  $1/16$ in. to  $1/8$ in. as the top run of the chain is lightly pressed up and down midway between the sprockets. When checking, try a number of positions and obtain the described adjustment at the tightest place. To adjust, first slacken the dynamo clamp bolt and then twist the unit bodily in its mounting in a forward or clockwise direction to tighten. Always check the adjustment after the clamp bolt has been re-tightened. It will be found that the tension of both dynamo and primary chains can be checked by the fingers passing through the inspection cap orifice, it being, of course, necessary to remove the cap for the purpose. This cap is released upon unscrewing the knurled edge screw.

## TO ADJUST THE MAGNETO CHAIN.

(Models 35/22, 35/26 and 35/14.)

Adjustment to the magneto chain is obtained by tilting the unit bodily on the lower crankcase bolt upon which the platform is mounted; the upper fixing bolt holes being slotted for the purpose. To adjust the chain, first remove the outer cover of crankcase, then slack off slightly only the two crankcase bolts by which the magneto platform is fixed and insert a lever or screwdriver under the top edge to force the back end up until the correct adjustment is obtained, when securely tighten the two fixing bolts and before replacing the outer chain cover smear the chain with grease if necessary.

NOTE.—The correct adjustment allows a whip of about  $1/16$ in. as the top run of the chain is slightly pressed up and down midway between the sprockets.

## TO ADJUST THE PRIMARY CHAIN.

To obtain adjustment for the primary chain, provision is made to swing the gear box bodily upon its lower fixing bolt. It will be observed that the upper fixing bolt operates in slotted holes to permit of the necessary movement. To make adjustment, the off-side nut of the top gear box fixing bolt must first be slackened. Then to tighten the chain adjustment, first slack off the nut on the adjuster bolt nearest the engine and turn the nut farthest from engine clockwise, until the correct chain adjustment is obtained, then re-tighten the nut nearest engine and also the top gear box fixing bolt nut. Correct chain adjustment should allow a whip or movement of  $1/16$ in. to  $1/8$ in. as the top run of the chain is pressed up and down midway between the sprockets.

NOTE.—Owing to the movement of the gear box necessary for correcting chain adjustments, some small alteration to the gear rod adjustment may be necessary; therefore, upon completion of the former, the adjustment of the gear control must always be checked and corrected if necessary. (See gear control adjustment. Hand only.)



## TO ADJUST THE REAR CHAIN.

Put down the centre prop stand, then slack, slightly only, both rear wheel spindle nuts. Then adjust chain as required by means of the bolts which pass through each of the fork ends, after which securely re-tighten spindle nuts. The correct adjustment (which should allow a whip of  $\frac{3}{16}$  in. to  $\frac{1}{2}$  in. when chain is pressed up and down) should be obtained for the tightest place.

NOTE.—Before tightening the rear chain, the adjustment of the front chain should be inspected and if attention to each is required, the latter should be treated first.

IMPORTANT.—Care is necessary when tightening rear chain to leave the wheel in correct alignment. When correct, a piece of thin string stretched taut across both wheels and about four inches from and parallel to the ground, should be observed to just touch each tyre at both sides of wheel centre simultaneously. Alternatively, a straight wooden batten about five feet long is a very handy article to be used for the purpose of checking wheel alignment, applied as in the case of string, parallel to and about four inches from the ground.

## ADJUSTMENT OF GEAR CONTROL (HAND CHANGE ONLY).

To test for correct gear rod adjustment, proceed as follows:—Place cycle on the stand and remove the split pin from the top gear rod yoke end pin (i.e., the pin which passes through the end of the gear lever). Also, at the same time, slack off the lock nut securing this top gear rod yoke end. Now place the gear lever into third position and after removing the top yoke end pin from which split pin has already been withdrawn, lightly alternatively pull and push the gear rod by hand in order to feel the action of the gear box internal spring indexing plunger. As the sliding gears move either side of the correct third gear position, the resistance of the spring plunger will be plainly felt, and the exact position at which this plunger is in full engagement with the third gear notch must be accurately and definitely found. Having established this correct position, offer up the gear rod to gear lever, which latter must, of course, be in the third gear position, and screw the top yoke end up or down, as the need may be, until the pin can be quite freely inserted. Before locking the yoke end in position, it is advisable to again obtain by hand the exact position of third gear, as already described, and check the rod length for correct setting, after which the yoke end may be secured by means of its lock nut and the pin re-fitted. It must be understood that if the correct adjustment is obtained for the third gear, all the remaining gears will also be correct as regards rod adjustment.

## TO DISMANTLE AND ADJUST WHEEL BEARINGS.

Instructions which must be carefully carried out for dismantling and re-assembling taper roller bearing hubs:—

To dismantle, release the locking nut and screw out the adjusting ring. The dished plate containing felt washer and plain

## To Dismantle and Adjust Wheel Bearings—contd.

plate will then drop out. Take out spring ring from the opposite side of hub and remove felt washer and hulder consisting of two plates and retaining ring, the latter being between the two plates. The spindle can now be pressed or driven out from either end, bringing with it one of the outer races. The other race can then be driven out.

To re-assemble, press in outer race on fixed or plain end of hub, taking great care that it goes in square. This race is pressed in about  $1/32$  in. beyond its actual position, to enable the felt washer and its retaining ring, together with the two plates, to be put in and the spring ring to snap into its groove. Care must be taken to put the plate with the larger hole in last. This is most important. This outer race can now be forced back until the plates are tight on the spring ring. The spindle can now be inserted, the short end being placed in first. The long end of the spindle must be on the adjusting side. The other race can now be pressed in until there is about  $1/16$  in. end play in the spindle. Insert plain plate and dished plate with felt washer, screw in adjusting ring, and gradually screw down until there is just a fraction of end play in the spindle. This should be .001 of an inch.

It is of the utmost importance that the bearings are not adjusted too tight as this would ruin them in a few miles. Having got this adjustment correct, the locking ring can be put on and tightened up, again taking care that the adjusting ring does not creep forward and make the bearings too tight.

## CLUTCH ADJUSTMENT.

In the event of clutch slip being experienced, the most likely cause is incorrect cable adjustment. When correct, it should be possible to move the actuating lever (part to which lower end of cable is attached) inwards and outwards slightly with the fingers, and if this free movement cannot be felt, the cable adjustment must be slackened. This is done by screwing down the cable adjuster on the gear box end plate.

## STEERING HEAD ADJUSTMENT.

The steering head should be occasionally tested for correct adjustment by exerting pressure upwards from the extreme tips of the handlebars while the steering damper is completely slackened off. Should any shake be apparent, the head clip pinch bolt nut should be slackened off and then the large nut underneath the steering damper knob should be turned in a clockwise direction until all trace of shake has disappeared, when the pinch bolt must be firmly re-tightened.

IMPORTANT.—To guard against unconsciously over-tightening the head bearings, the effect of which is extremely difficult steering, it is advisable to jack up the front of the machine (a box of suitable height under the crankcase will serve), in order that all shake may be taken up satisfactorily and the steering head left perfectly free.

## FRONT FORK SPINDLE ADJUSTMENT.

Provision is made for taking up side or end wear of the various fork spindle bearings. The need for adjustment will be made apparent by a click or creaking noise when the steering head is abruptly turned. By placing the fingers partly over the spindle link end and partly upon the lug through which the spindle passes, while turning the steering head, first ascertain which spindle or spindles require adjustment, then after slackening off the right side nut on the spindle to be adjusted, carefully turn the spindle bodily, by means of its hexagonal head, in a clockwise direction to tighten, or vice versa to slacken. Do not adjust more than one half a revolution at a time before a re-trial with the nut again tightened. Care is essential to avoid tight adjustment which will make the fork stiff in action or entirely prevent it functioning. The necessary friction damper effect is provided independently and is adjusted as follows:—

### TO ADJUST FORK ACTION DAMPER.

The fork action damper can best be adjusted while cycle is actually in motion, and a badly corrugated surface such as may be found on many bus routes provides the best condition for the purpose. The ebonite damper hand nut should be screwed sufficiently tight to make the fork action sluggish under such circumstances as those described and will subsequently require very little variation for other conditions of road surface to provide the maximum degree of comfort.

## CARBURETTOR ADJUSTMENT.

Although owners are advised to refrain from tampering without good cause with the setting of the carburettor, a rough idea how this unit functions and how adjustments may be effected is given below:—

The correct level of petrol is maintained by means of a float and needle valve, operating in much the same manner as the ball float and valve of an ordinary domestic water cistern. The correct level is obtained by the carburettor manufacturers and no alteration under any circumstances should be made. In the event of a leaky float or worn needle valve, the part in question should be replaced. Control over the petrol supply to the engine is obtained firstly by the main jet, and secondly by means of a taper needle attached to the throttle valve and operating in a tubular extension of the main jet. The main jet controls the mixture entirely from  $\frac{1}{4}$  to full throttle, and the adjustable taper needle from  $\frac{1}{4}$  down to  $\frac{1}{2}$  throttle. The cut-away portion at the air intake side of throttle valve controls mixture from  $\frac{1}{2}$  throttle down to about  $\frac{1}{4}$  open, and a pilot jet with independently adjusted air supply takes care of idling on nearly closed throttle up to about  $\frac{1}{4}$  open. These various stages of control must be borne in mind when any adjustment is contemplated. The correct jet size and throttle cut-away is selected for each model and should not be altered without some very good reason. For Models 35/12 and 35/22, the combination

## Carburettor Adjustment—contd.

is jet 120 and throttle slide 5x3; for Models 35/22 and 35/26, jet 120 and throttle slide 5x4, and for Models 35/4 and 35/14, jet 130 and throttle slide 6x4. With these combinations it is possible to use full or nearly full air under all conditions, except perhaps when the engine is pulling hard up hill on full throttle, when some benefit may be obtained by closing the air down a trifle. Weak mixture is always indicated by popping or spitting at the air intake, whilst a rich mixture usually causes bumpy or jerky running in extreme cases, accompanied by black smoke from the exhaust. A rough test for correct setting is to warm the engine up and then fully retard the ignition, and with the air about  $\frac{3}{4}$  open slowly open up the throttle to full open, during which the engine should respond without a misfire, but upon a sudden opening of the throttle again with fully retarded ignition and about  $\frac{1}{4}$  air, it should splutter and stop. This is, of course, only a rough test, but is, nevertheless, a fairly accurate guide to correct main jet and needle setting. To check the pilot jet and air control setting, warm up the engine, and with the ignition about  $\frac{1}{2}$  advanced and air about  $\frac{1}{4}$  open, with throttle almost closed, the engine should idle positively and evenly. If it fails to do so, slacken the lock nut securing the pilot jet air screw, which will be observed at the base of the mixing chamber, and find a position at which even firing is obtained. The adjustment of this screw is not unduly sensitive and it should be possible to obtain the correct adjustment in a few seconds.

Before concluding that incorrect carburation is responsible for heavy consumption, and before carrying out any of the tests described, make quite certain that the ignition is set correctly. This is most important. In the event of adjustment of the air screw failing to effect slow running in the manner described, it may be reasonably assumed that the minute passage for petrol has become choked. This is always a possible danger unless meticulous care is taken to prevent the entry of dust or foreign matter of any description into the petrol tank. The jet or petrol passage in question consists of a small hole drilled in the side of the sprayer base. This sprayer base may be pushed out of the mixing chamber upon removing the float chamber and the large nut at the bottom of the mixing chamber. To make the location of the petrol passage quite clear, a line illustration is shown and in the event of difficulty being experienced, a fine piece of steel wire (a strand of Bowden cable will do) should be passed through the very small hole indicated by an arrow.

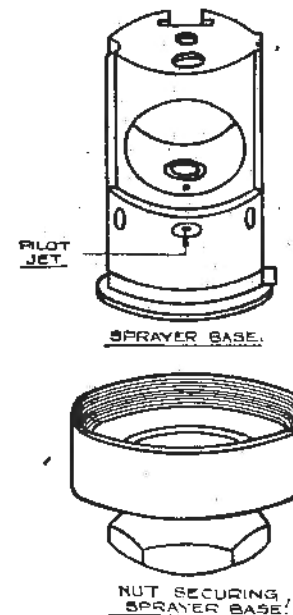

## CARE OF BATTERY.

### Carburettor Adjustment—contd.

#### Failure to obtain good idling may be due to:—

- 1.—Air leaks, either at the junction of the carburettor and engine, or by reason of a badly worn inlet valve stem or guide.
- 2.—Faulty valve seatings.
- 3.—Spark plug faulty or points too close.
- 4.—Too much ignition advance.
- 5.—Contact points dirty or setting too close.
- 6.—Defective sparking plug cable.

#### Failure to obtain satisfactory petrol consumption may be due to:—

- 1.—Late ignition setting (carefully follow instructions).
- 2.—Bad air leaks (most likely distorted flange).
- 3.—Weakened valve springs (renew).
- 4.—Leaky float, causing flooding (renew).
- 5.—Taper needle extension insufficient (note position before altering).
- 6.—Compression poor, due to worn piston rings, or defective valve seatings (test compression with wide open throttle).

## INSTRUCTIONS FOR THE ELECTRICAL EQUIPMENT.

Miller equipment is used on coil ignition Models 35/4, 35/12 and 35/16, while Lucas equipment is utilised on magneto ignition models. Both systems are identical with the exception that the latter models are provided with a detachable combined panel and inspection lamp, while the panel lamp on the coil ignition models is a fixture. In each case the head lamp is fitted with a double filament driving light bulb and also a parking light bulb, the dipped filament being brought into instant use as and when required by means of a knurled switch ring on the left handlebar. As in car practice, a red warning light is provided on the panel of coil ignition models to remind the driver to switch off the ignition when cycle is stationary. This warning light only appears when breaker points are together and, consequently, continually flickers while the engine is running.

The dynamo current output is so controlled that when the panel switch is at position "C" (daylight position) only half its normal output passes to the battery (about 2 amps.). When the switch is turned to position "H" or "L," the charging rate is automatically increased to its maximum, which is sufficient to cover the consumption of the lamps and still leave a balance of 1 amp. on position "H," and 4 amps. on position "L" (for town riding). By this combination it is within the rider's control to maintain a fully charged battery under all circumstances and over-charging is practically impossible.

**Topping Up.**—At least once a month, the vent plugs in the top of the battery should be removed and the level of the acid solution examined. If necessary, distilled water, which can be obtained at all chemists and most garages, should be added to bring to the level above the top of the plates, but well short of the bottom of the vent plugs. When examining the cells, do not hold a naked light near a vent, as there is a danger of igniting the gas coming from the plates.

**Storage.**—If the equipment is laid by for several months, the battery must be given a small charge from a separate source of electrical energy about once a fortnight, in order to obviate any permanent sulphation of the plates. In no circumstances must the electrolyte be removed from the battery and the plates allowed to dry, as certain changes take place which result in loss of capacity.

**Testing the Condition of the Battery.**—It is advisable to complete the inspection by measuring the specific gravity of the acid, as this is a very good indication of the state of charge of the battery.

An instrument known as a "Hydrometer" is employed for this purpose. These can be bought at any Lucas Service Depot, price 4s. 6d.

The specific gravity figures are: 1.285 to 1.300 when fully charged, about 1.210 when half discharged, and about 1.150 when fully discharged.

## DYNAMO.

The only parts of the dynamo calling for occasional attention are the brushes and the commutator, which are readily accessible when the end cover is removed. The brushes should slide freely in their holders. They should be clean and the face in contact with the commutator should appear uniformly polished. Dirty brushes may be cleaned with a cloth moistened with petrol. The commutator surface must be kept clean and free from oil or brush dust.

See earlier instructions re dynamo lubrication.

## CONTACT BREAKER.

Occasionally remove the bakelite contact breaker cover and examine the contacts. If they are burned or blackened, clean with a very fine emery cloth and afterwards with a cloth moistened with petrol. Take care to wipe away all particles of dirt or metal dust.

## ADJUSTMENT.

The contact breaker gap is carefully set and should not be altered unless it varies considerably from the correct setting. If adjustment is necessary, proceed as follows—

### Adjustment—contd.

Turn the engine until it is seen that the contacts are fully opened, then slacken the nut securing the stationary contact screw and adjust this screw until the gap is about .018 to .020. After making the adjustment, care must be taken to tighten the locking nut by which the stationary contact screw is secured.

NOTE.—Check contact breaker gap at 100 and 300 miles. Owing to an initial settling down, there is a tendency for the gap to decrease in the first few hundred miles of use. This may seriously affect ignition setting. Subsequently, adjustment will only be necessary at long intervals, but should be checked every 1,000 miles.

### PERIODICAL INSPECTION OF NUTS, ETC.

Satisfactory service depends largely upon the necessary immediate attention to details. The old adage, "A stitch in time saves nine," applies with particular force to motor cycle maintenance. Make a point of occasionally testing with a spanner the security of all nuts. There is possibly more dissatisfaction and damage caused through neglecting details, than for any other reason. It must be remembered that a motor cycle is a highly specialised piece of engineering and that while it does not call for great engineering skill in driving, the exercise of a little mechanical sense and the occasional use of a spanner, cleaning cloth, etc., is very necessary if the maximum service is to be obtained with the requisite degree of satisfaction. Therefore, do not wait until tomorrow; but adjust it now.

### CLEANING.

If the machine is used to any extent in bad weather, a small hose is almost indispensable for removing mud. Care should be exercised to avoid directing water on to the engine, carburettor, or other such parts. If a hose is not available, soak dirt with paraffin before removing. Do not attempt to rub or brush mud off an enamel surface when dry, or the polish will soon be destroyed. For the engine, magneto, etc., a good stiff paint brush and pot of petrol is preferable.

### TYRES AND SERVICE.

To obtain satisfactory life and service from the tyres is largely within the user's control, and the first essential to obtain this is proper inflation. The correct amount of pressure is governed substantially by the load to be carried and it is, therefore, difficult to lay down a hard and fast ruling. Assuming the weight of driver to be normal, the pressures recommended may be regarded as satisfactory, and we urge all users to make a practice of checking the actual pressure by means of a low-pressure Schrader tyre gauge. This takes a few

### Tyres and Service contd

seconds only and will amply repay the owner by reason of additional service and immunity from failures.

	Solo.	With Pillion.
Front tyre, 26x3.25	14-15 lbs.	16-17 lbs.
Rear tyre, 26x3.25	20-22 lbs.	22-24 lbs.
Sidecar tyre, 26x3.25	...	14-15 lbs.

The above recommended pressures apply to average weight drivers. For abnormal weight drivers, or for carrying pillion passengers, add two pounds per square inch to rear tyre only.

### CORRECTIVE MEASURES.

No adjustment should be made or any part tampered with until the cause of the trouble is known. Otherwise adjustments which are correct may be destroyed.

#### Engine Suddenly Stops:—

- Petrol shortage in tank.
- Choked petrol supply pipe or tap.
- Choked main jet.
- Water in float chamber.
- Oiled-up or fouled sparking plug.
- Water on H.T. pick-up or on sparking plug.

#### Engine Fails to Start, or Difficult Starting:—

- Lack of fuel, or insufficient flooding if cold.
- Excessive flooding, allowing neat petrol to enter cylinder.
- Oiled-up sparking plug.
- Stuck-up valve, or valve stem sticky.
- Weak valve spring, or valve not seating properly.
- Too liberal throttle opening.
- Pilot jet choked.
- Contact breaker points dirty, or gap incorrect.

#### Loss of Power:—

- Valve or valves not seating properly.\*
- Weak valve spring or springs.
- No tappet clearance, or excessive clearance.
- Lack of oil in tank.
- Brakes too closely adjusted.
- Badly fitting or broken piston rings.
- Punctured carburettor float.
- Creeping ignition lever.

**Engine Overheats:—**

- Lack of proper lubrication.
- Weak valve springs.
- Pitted valve seats.
- Worn piston rings.
- Late ignition setting.
- Punctured float, causing rich mixture.
- Air control to carburettor out of order.
- Creeping ignition lever.

**Engine Misses Fire:—**

- Valve spring weak.
- Defective or oiled plug.
- Incorrectly adjusted contact breaker.
- Incorrectly adjusted tappets.
- Defective sparking plug cable.
- Oil on contact breaker points.

**Excessive Oil Consumption:—**

- Stoppage or partial stoppage in pipe returning oil from engine to tank.
- Clogged or partially clogged cartridge filter in oil tank.  
(Drain sump and test with filter removed.)
- Badly worn or stuck-up piston rings, causing high pressure in engine crankcase.
- Air leak at rear oil pump end cap.

**LEGAL MATTERS.**

NOTE.—In view of the growing public objection to noisy motor cycles, a word of warning on this subject may not be out of place here. Firstly, it has been noted, and freely commented, that much of the noise complained of is unnecessary, being due to injudicious driving as, for instance, violently accelerating from a standstill, racing the engine when stationary, driving on full throttle when ascending hills in residential districts, etc. Any motor cycle or, for that matter, any motor vehicle, driven in this manner creates abnormal noise and, in the interests of all, we earnestly implore every A.J.S. owner to studiously refrain from any of the practices enumerated.

To comply with the law relating to motor cycles, every owner must:—

- 1.—Hold a driver's licence, which can be obtained from the Chief Constable or Corporation of a County Borough, or from the County Council. The charge for this licence is 5s. yearly and must be renewed annually from the date of issue. A motor car driver's licence covers the driving of a motor cycle.
- 2.—Insure against Third Party Risks (other risks may also be embodied in the Insurance Policy as owner may desire, but are not compulsory by law), and obtain from the Insurance Company decided upon, either a Certificate of Insurance covering the full period of twelve months or, alternatively, as is most general, a temporary Certificate, which must be produced when applying for Revenue Licence.
- 3.—Apply to the Taxation Department of the Local Authority of the district in which the vehicle is to be ordinarily kept, for Inland Revenue Licence and Registration Form (motor cycles only). The address of the above Taxation Department can be obtained by enquiry at a Post Office.
- 4.—The form, when obtained, must be filled in and returned, accompanied by the Insurance Certificate referred to above, and the requisite remittance, which varies according to the date of registration and the term covered.
- 5.—See that the rear number plate is illuminated at night.
- 6.—Never drive at a speed which is dangerous to the public.
- 7.—Wherever necessary, give audible and sufficient warning by horn, or other instrument, of the approach of his motor cycle, except between the hours of 11.30 p.m. and 7.30 a.m.

NOTE.—In view of impending alterations in road traffic regulations in the near future, new owners are advised to make further enquiries unless quite conversant with all new regulations at the date of purchase.

# GUARANTEE.

We give the following guarantee with our motor cycles, motor cycle combinations and sidecars, which is given in place of any implied conditions, warranties or liabilities whatsoever, statutory or otherwise, all such implied conditions, warranties and liabilities being in all cases excluded. Any statement, description, condition or representation contained in any catalogue, advertisement, leaflet or other publication shall not be construed as enlarging, varying or over-riding this guarantee. In the case of machines which have been used for "hiring out" purposes, or racing, or from which the trade mark, name or manufacturing number has been removed, no guarantee of any kind is given or is to be implied.

WE GUARANTEE, subject to the conditions mentioned below, that all precautions which are usual and reasonable have been taken by us to secure excellence of materials and workmanship, but this guarantee is to extend and be in force for six months only from date of purchase, and damages for which we make ourselves responsible under this guarantee are limited to the free supply of a new part in exchange for the part of the motor cycle, motor cycle combination or sidecar which may have proved defective. We do not undertake to replace or refix, or bear the cost of replacing or refixing such new part in the motor cycle, motor cycle combination or sidecar. We undertake, subject to the conditions mentioned below, to make good at any time within six months any defects in these respects. As motor cycles, motor cycle combinations and sidecars are liable to derangement by neglect or misuse, this guarantee does not apply to defects caused by wear and tear, misuse or neglect.

The term "misuse" shall include amongst others the following acts:—

- 1.—The attaching of a sidecar to the motor cycle in such a manner as to cause damage or calculated to render the latter unsafe when ridden.
- 2.—The use of a motor cycle and sidecar combined when carrying more persons or a greater weight than for which the machine was designed by the manufacturers.
- 3.—The attaching of a sidecar by any form of attachment not provided, supplied or approved by the manufacturers, or to a motor cycle which is not designed for such use.

Any motor cycle, motor cycle combination or sidecar sent to us to be plated, enamelled or repaired, will be repaired upon the following conditions, i.e., we guarantee that all precautions which are usual and reasonable have been taken by us to secure excellence of materials

Guarantee—contd.

and workmanship, such guarantee to extend and be in force for three months only from the time such work shall have been executed, or until the expiration of the six months above referred to, and this guarantee is in lieu and in exclusion of any common law or statute warranty or condition, and the damages recoverable are limited to the cost of any further work which may be necessary to amend and make good the work found to be defective.

## CONDITIONS OF GUARANTEE.

If a defective part should be found in our motor cycles, motor cycle combinations or sidecars, or in any part supplied by way of exchange before referred to, it must be sent to us CARRIAGE PAID and accompanied by an intimation from the owner that he desires to have it repaired or exchanged free of charge under our guarantee, and he must also furnish us at the same time with the number of the machine, the date of the purchase, or the date at which the alleged defective part was exchanged, as the case may be.

Failing compliance with the above, such articles will lie here AT THE RISK OF THE OWNER, and this guarantee and any implied guarantee, warranty or condition shall not be enforceable.

We do not guarantee specialities such as tyres, saddles, chains, magnetos, lamps, etc., or any component parts supplied to the order of the purchaser differing from standard specifications supplied with our motor cycles, motor cycle combinations, sidecars or otherwise.

IMPORTANT NOTE.—Any part sent to us for any reason whatsoever must bear distinctly the sender's name and address, and instructions or requests relative to parts must be sent separately by letter post.

A.J.S. MOTOR CYCLES.

## SPARES SECTION.

Models 35/4, 35/12, 35/14, 35/16, 35/22 and 35/26.

### INTRODUCTION.

We have pleasure in presenting this Spares List for the A.J.S. Models 35/4, 35/12, 35/14, 35/16, 35/22 and 35/26.

Every part likely to be required can be readily found by reference to the various illustrations.

Every part has a distinctive number and in ordering care must be taken to give both description and part number.

Read carefully rules on Pages 29, 30 and 31.

Always quote both engine and frame number of your cycle when corresponding or ordering spare parts.

A.J.S. MOTOR CYCLES

Proprietors: Matchless Motor Cycles (Colliers) Ltd.

### TERMS OF BUSINESS.

Our invariable rule in this department is net cash with order. Remittance to £1 in value may be sent by Postal Order, but over this amount it is advisable to remit by cheque. Cheques to be made payable to A.J.S. Motor Cycles and crossed. When making a remittance by Telegraph Money Order, the name and address of sender should be included, as unless this is done, the Post Office do not give this information in the telegram. We frequently receive Telegraph Money Orders without sender's name, with the result that we cannot trace by whom the amount is sent and we have to await until the customer writes complaining about delay before the matter can receive attention. If remittance is not sufficient to pay for postage or carriage, goods will be sent "Carriage Forward" (Goods Train).

All repairs accounts are strictly net cash before delivery.

The prices in this list are subject to alteration without notice.

Only goods to the value of 5s. and over are sent upon request, per C.O.D.

IMPORTANT NOTE RE C.O.D.—Owing to the labour involved and to the fact that the minimum C.O.D. fee is 10d., only goods to the value of 5s. and over can be sent on the above system.

### DEPOSIT ACCOUNT.

We strongly advise all owners of A.J.S. Motor Cycles to take advantage of our "Deposit System." It often occurs that parts are required by return, but unless customers have a current account, there is the inevitable delay while a pro forma invoice is sent, and we have to await receipt of the remittance before the goods can be despatched. This delay causes considerable inconvenience to the party concerned, and can be avoided by opening a Deposit Account.

A remittance of not less than £2 entitles a customer to this form of account, and when goods are ordered by phone, telegram, or letter they will be despatched at the earliest possible moment by the quickest route. Invoices will be sent for all goods supplied and a statement will be rendered when required showing amount of deposit in hand. Customers will be notified immediately their deposit becomes exhausted, so that they can renew same. We are at all times prepared to return balance of deposit upon request.

Kindly note when ordering to mention "Deposit" or quote reference as shown on monthly statements.

### FOREIGN ORDERS.

The conditions governing the supply of spares against Home orders equally apply to orders received from Overseas. It must be noted that the C.O.D. system (Cash on Delivery or Value Payable by Post) can only be used in connection with Overseas orders when those orders are accompanied with cash to not less than 25 per cent. of the value of the complete order. This condition is necessary because of the difficulties presented by foreign exchange and the expenses that may be incurred if delivery of the consignment cannot be made, such as might arise in the event of the client refusing to take delivery.

# ENGINE PARTS.

Part No.	Description.	Models.	Price Each.
			£ s. d.
<b>A.</b>			
20821	Axle for flywheel, driving side	All models	11 6
DE26	Axle for flywheel, timing side	All models	8 0
AE17	Axle for flywheel, crankpin	35 12 and 22	4 0
D8E2017	Axle for flywheel, crankpin	35 16, 4, 26, 14	7 6
<b>B.</b>			
DE27	Bush for flywheel axle, timing side	All models	3 0
BE45	Bush for guidepin	35 12 and 22	2 6
LSF86	Bush for guidepin	35 4, 14, 16, 26	2 0
LSF318 A	Big end liner or bush	35 12 and 22	2 6
MX2F218	Big end liner or bush	35 16, 4, 14, 26	4 0
35 22 E136	Bush for exhaust camshaft, in timing cover	All models	1 0
CE36	Bush for inlet camshaft, crankcase or timing cover end	All models	1 0
15985	Bush bearing for overhead rocker axle (2 off)	35 12, 16, 22, 26	2 3
RLS7	Bearing, journal for flywheel axle bearing driving side (2 off)	All models	10 0
20822	Bearing spacer, fits between above	All models	6 6
<b>C.</b>			
FE2	Cylinder head	35 12	1 16 9
20815	Cylinder head	35 16	2 5 9
D5E15-2	Cylinder head	35 4 and 14	1 0 4
35 F2 E2	Cylinder head	35 22	2 0 0
35 F3 E2	Cylinder head	35 26	2 7 6
FF88	Cylinder head fixing bolts (4 off)	35 12, 16, 22	1 6 0
12574	Washers for above (4 off)	35 12 and 22	1 1
V3E1088	Cylinder head fixing bolts (5 off)	35 4 and 14	6 6
20571	Cylinder head gasket	35 12 and 22	5 5
12268	Cylinder head gasket	35 16 and 26	5 5
D5E1504	Cylinder head gasket	35 4 and 14	1 5
AF64	Camshaft driving studs (2 off)	All models	2 2
STD4	Nuts for above		2 2
FE1	Cylinder barrel	35 12 and 22	1 17 6
20814	Cylinder barrel	35 16 and 26	1 17 6
D5E1501	Cylinder barrel	35 4	2 12 6
BE2	Cylinder barrel holding down studs (4 off)	35 12 and 22	5 5
STD4	Nuts for above (4 off)	35 12 and 22	2 2
D5E326	Cylinder barrel holding down studs (4 off)	35 16 and 26	3 3
LSF514	Nuts for above (4 off)	35 16 and 26	5 5
D5E1526	Cylinder barrel holding down studs (3 off)	35 4 and 14	5 5
TE197	Nut for above (1 off)	35 4 and 14	5 5
D5E1557	Nut for above (1 off)	35 4 and 14	5 5
R6E617	Cylinder base washer	35 12 and 22	2 2
TR9F505	Cylinder base washer	35 16 and 26	2 2
D5E5-5	Cylinder base washer	35 4 and 14	2 2
2-587	Crank axle, timing and timing side halves (supplied complete with studs and bushes only)	35 12 and 22	4 5 0
2-588	Do. do.	35 16 and 26	4 5 0
105775	Do. do.	35 4 and 14	4 5 0
HE18	Crankcase pin bolt, 7/8" diam., 4 1/2" long	All models	3 3
STD5	Nut for 7/8" bolt (2 off)	All models	2 2
STD4	Nut for 7/8" bolt (2 off)	All models	2 2
LSF239	Crankcase drain plug	All models	4 4
D2E1216	Connecting rod bare, less small and big end bushes	35 12 and 22	16 0
FE416	Connecting rod bare, less small and big end bushes	35 16, 4, 26, 14	16 0
D2E1244	Connecting rod with small and big end bushes	35 12 and 22	1 2 9
CE444	Connecting rod with small and big end bushes	35 16, 4, 26, 14	1 3 0
AE17 AS	Big end assembly (crankpin, washers, rollers, nuts and big end liner)	35 12 and 22	15 0
D8E2017 AS	Big end assembly (crankpin, washers, rollers, nuts, big end liner and cage)	35 4, 14, 16, 26	1 6 0
LSF318 A	Connecting rod big end liner	35 12 and 22	2 6 6
MX2F218	Connecting rod big end liner	35 26, 14, 16, 4	4 6 0
AE17	Crankpin	35 12 and 22	4 6 0
D8E2017	Crankpin	35 16, 4, 14, 26	7 6 6
LSF396	Crankpin (3 to a set)	35 12 and 22	2 2
	35 in a set	35 16, 4, 26, 14	2 2
DE19	Crankpin washers	35 12 and 22	1 0
D8E2018	Crankpin washers	35 16, 4, 14, 26	1 0
LSF70	Crankpin bearing nuts	35 12 and 22	1 5
V2E126	Crankpin bearing nuts	35 16, 4, 14, 26	7 5

Always quote both Engine and Frame Numbers when ordering Spare Parts.

Part No.	Description.	Models.	Price Each.
			£ s. d.
MX28318	Crankpin cage	35 16, 4, 14, 26	6 0
FE532	Camshaft, inlet	All models	9 6
FE531	Camshaft, exhaust	35 12, 16, 4	10 6
35 22 E131	Camshaft, exhaust	35 14, 22, 26	10 6
STD4	Nut for above	35 14, 22, 26	2 2
R+E1036	Cap for outer inlet camshaft bush	All models	3 3
FE65	Covering tubes for tappet push rods	35 12 and 22	5 6
20810	Covering tubes for tappet push rods	35 16 and 26	3 6
CE43	Pinning screw for above (2 off)	35 12, 16, 22, 26	1 1
X2E1085	Cover for valve chest	35 4 and 14	3 0
X2E1185	Washer for above	35 4 and 14	4 4
D5E582	Stud for valve chest	35 4 and 14	5 5
KSTD4	Nut for valve chest stud	35 4 and 14	2 9
AE86	Knob for cover stud	35 4 and 14	2 2
AE86W	Oil retaining washer for knob	35 4 and 14	2 2
<b>D.</b>			
LSF239	Drain plug for crankcase	All models	4 4
CE39	Dowel peg, locating timing cover, fits in crankcase (2 off)	All models	1 1
<b>F.</b>			
FE410	Flywheel, driving side	35 12 and 22	10 0
20831	Do. do.	35 16 and 26	12 6
20858	Do. do.	35 4 and 14	12 6
FF425	Flywheel, timing side	35 12 and 22	10 0
D3E2325	Do. do.	35 16 and 26	12 6
D8E2825	Do. do.	35 4 and 14	12 6
20821	Flywheel axle or shaft, driving side	All models	11 6
12074 6	Key for above	All models	2 2
11955	Nut securing axle to flywheel	All models	5 5
STD15	Lock screw for above	All models	1 1
RLS7	Ball or journal bearing for above shaft	All models	10 0
DE26	Flywheel axle shaft, timing side	All models	8 0
LE85 N	Key for above shaft	All models	1 1
LS3E70	Nut securing above axle to flywheel	All models	9 9
STD15	Lock screw for above	All models	1 1
RE82	Nut securing small timing pinion (left-hand thread)	All models	2 2
DE27	Bush for timing side flywheel axle	All models	5 0
<b>G.</b>			
D2E1214	Guidepin	35 12 and 22	2 0
D3E314	Guidepin	35 16 and 26	2 0
D5E614	Guidepin	35 4 and 14	5 5
12366	Guidepin securing rings	All models	2 6
RE45	Guidepin bush	35 12 and 22	0 0
LSF89	Guide for tappet, inlet	35 16, 4, 26, 14	0 6
FE83	Guide for tappet, inlet	35 4 and 14	0 6
D2E1285	Guide for tappet, exhaust	35 12, 16, 22, 26	4 1
FE283	Guide for tappet, exhaust	35 4 and 14	4 1
D5E2583	Guide for tappet, exhaust	35 12, 16, 22, 26	0 3
LE148-S	Guide for valve	35 4 and 14	2 5
AE48	Guide for valve	35 4 and 14	2 5
AB68	Grease nipple for rocker box, plain type (3 off)	35 12, 16, 22, 26	2 2
P165	Grease nipple for rocker box, angular type	35 12, 16, 22, 26	2 2
<b>O.</b>			
BE60	Oil pump plunger or shaft	All models	6 0
AE66	Oil pump plunger guide screw	All models	6 6
AE97	Oil pump plunger end cap (2 off)	All models	6 6
AE98	Small hexagon screws for above (8 off)	All models	3 3
AE99	Paper washers for above end caps	All models	1 1
<b>P.</b>			
D2E1212	Piston, standard size	35 12 and 22	15 0
D3E312	Piston, standard size	35 16 and 26	11 6
D5E712	Piston, standard size	35 4 and 14	15 0
OD5E1212	Piston, .020" oversize	35 12 and 22	15 0
OD5E312	Piston, .020" oversize	35 16 and 26	11 0
OD5E712	Piston, .020" oversize	35 4 and 14	15 0
DE11	Piston ring (3 to a set)	35 12 and 22	1 0
D3E311	Piston ring (3 to a set)	35 16 and 26	1 0
LSF611	Piston ring (3 to a set)	35 4 and 14	1 0
OD5E11	Piston ring, .020" oversize	35 12 and 22	1 0

Always quote both Engine and Frame Numbers when ordering Spare Parts.



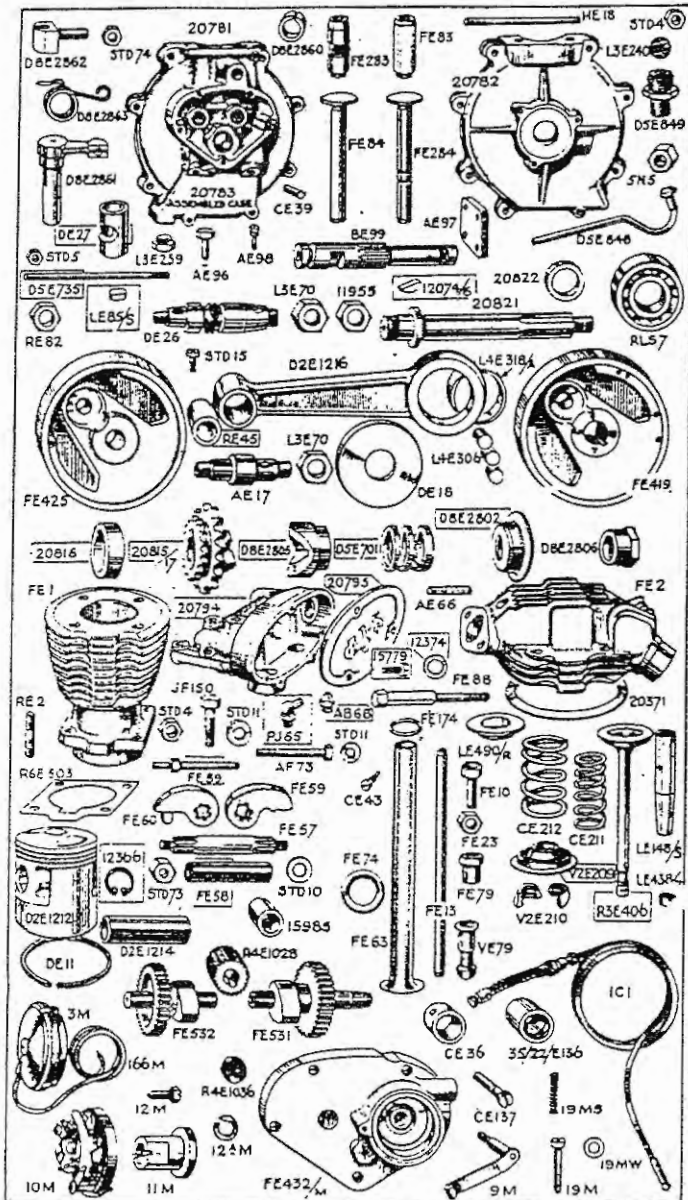

Part No.	Description.	Models.	Price Each.
OD3E311	Piston ring, .020" oversize	35 16 and 26	£ 8. d.
OD3E611	Piston ring, .020" oversize	35 4 and 14	1 0
D2E1212A	Piston complete with rings, gudgeon pin and securing rings, standard size	35 12 and 22	16 5
D3E312A	Ditto	35 16 and 26	17 8
D5E712A	Ditto	35 4 and 14	1 11
OD2E1212A	Piston complete, .020" oversize, with rings, gudgeon pin and securing rings	35 12 and 22	16 5
OD3E312A	Ditto	35 16 and 26	17 8
OD5E712A	Ditto	35 4 and 14	1 11
R4E1028	Pinion, small timing	All models	3 9
LE85S	Key for above	All models	3 9
RE82	Nut securing above pinion, left-hand thread	All models	1 2
FE13	Push rods only, less ends	35 12 and 22	1 2
20818	Push rods only, less ends	35 16 and 26	1 0
VE79	Push rod hardened steel ball end, bottom	35 12, 16, 22, 26	1 9
FE79	Push rod adjusting screw or bolt	35 12, 16, 22, 26	1 0
FE16	Lock nut for above	35 12, 16, 22, 26	4
FE23	Push rod cover tubes	35-12 and 22	3 6
20819	Ditto	35 16 and 26	3 6
FE74	Rubber rings for bottom end of above	35 12, 16, 22, 26	1
FE174	Rubber rings for top end of above	35 12, 16, 22, 26	1
CE43	Screws securing push rod cover tubes to rocker box	35 12, 16, 22, 26	1
FE14	Push rod assembled with ends	35 12 and 22	4 3
20818AS	Ditto	35 16 and 26	4 3
CE39	Pez. dowel, locating timing gear cover	All models	1

R.

D3E849	Release valv. body	All models	1 0
L3E240	Release valve diaphragm	All models	1 2
D5E848	Release valve oil pipe with nipple	All models	1 3
SL4	Nipple for release valve oil pipe	All models	4
SN5	Union nut for above	All models	2
L4E306	Rollers for big end (30 off)	35 12 and 22	2
L4E306	Rollers for big end (28 off)	35 16, 4, 26, 14	2 6
MXE218	Roller race or liner for big end	35 12 and 22	4 0
20794	Rocker box, bare, less all fittings	35 16, 4, 26, 14	18 6
20795	Rocker box aluminium cover	35 12, 16, 22, 26	2 6
15779	Rocker box cover screws (3 off)	35 12, 16, 22, 26	3 3
FE57	Rocker spindle (splined ends) (2)	35 12, 16, 22, 26	5 6
STD73	End nuts for above (4 off)	35 12, 16, 22, 26	2 8
STD10	Washers for above (4 off)	35 12, 16, 22, 26	1
FE58	Rocker spindle hardened steel sleeves 2 off)	35 12, 16, 22, 26	3 0
15985	Bronze bushes for above (4 off)	35 12, 16, 22, 26	3 0
FE59	Rockers, valve end	35 12, 16, 22, 26	2 6
FE60	Rockers, push rod end	35 12, 16, 22, 26	2 6
AB68	Rocker box grease nipple, plain type (3 off)	35 12, 16, 22, 26	2
PJ65	Rocker box grease nipple, angular type	35 12, 16, 22, 26	4
AFT3	Rocker box long securing bolt	35 12, 16, 22, 26	4
JF150	Rocker box bolt, short (2 off)	35 12, 16, 22, 26	4
FE79	Rocker box bolt, long (1 off)	35 16 and 26	4
FE89	Rocker box bolt with threaded extension	35 12 and 22	7
STD11	Washers for above bolts (4 off)	35 12, 16, 22, 26	1
FE74	Rubber ring for bottom of push rod cover tubes	35 12, 16, 22, 26	3
FE174	Rubber ring for top end of push rod cover tubes	35 12, 16, 22, 26	1

S.

20815.17	Engine and dynamo driving sprocket, 17 by 17 teeth	35-12 and 22	0 6
20815 18	Ditto, 18 by 17 teeth	35-4 and 14	0 6
20815 19	Ditto, 19 by 17 teeth	35 16 and 26	0 6
D8E2805	Shock absorber ram	All models	3 0
D5E701	Spring for engine sprocket shock absorber	35-12, 16, 22, 26	1 6
CE101	Distance collar for shock absorber	35 4 and 14	1 6
20816	Collared nut securing shock absorber	All models	6
D8E2806	Shock absorber spring cap	All models	8
D8E2802	Screws securing timing gear cover (5 off)	All models	2
CE137	Screws securing top end of push rod cover tubes	35 12, 16, 22, 26	1
12366	Securing ring for gudgeon pin	All models	4
FE58	Sleeves, hardened steel for rocker spindles	35 12, 16, 22, 26	3 0
35 22-E138	Sprocket for magnets chain for cam shafts	35 22, 26, 14	2 6

Always quote both Engine and Frame Numbers when ordering Spare Parts.

T.

IGNITION (35/4, 12, 16 only).

Part No.	Description.	Models.	Price Each.
			£ s. d.
FF47 M	Timing gear cover with camshaft bushes only	35 12, 16, 4	12 6 0
35 22 E52	Idiot	35 22, 26, 14	12 6 0
35 22 E26	Magneto chain cover, front half	35 22, 26, 14	5 0 0
FF47	Screws for above 5 off	35 22, 26, 14	2 2 0
FF47	Screws securing timing gear cover (5 off)	35 12, 16, 4	2 2 0
FF47	Timing gear camshaft, inlet	All models	0 6 6
FF47	Timing gear camshaft, exhaust	35 12, 16, 4	10 6 6
35 22 E131	Timing gear camshaft, exhaust	35 14, 22, 26	10 6 6
ST14	Nut for above	35 22, 26, 14	2 2 0
R4E1 16	Timing gear cover cap, covering outer inlet camshaft bush	All models	3 3 3
R4E1 28	Timing gear small pinion	All models	3 3 3
LEB14	Key for above	All models	3 3 3
R4E2	Nut securing above pinion (left-hand thread)	All models	2 2 0
R4E2	Tappet, inlet	35 12, 16, 22, 26	2 2 0
R4E2	Tappet, exhaust	35 4 and 14	2 2 0
R4E2	Tappet, inlet	35 12, 16, 22, 26	2 2 0
R4E2	Tappet, exhaust	35 4 and 14	2 2 0
R4E2	Tappet guide, inlet	35 12, 16, 22, 26	2 2 0
R4E2	Tappet guide, inlet	35 4 and 14	2 2 0
R4E2	Tappet guide, exhaust	35 12, 16, 22, 26	2 2 0
R4E2	Tappet guide, exhaust	35 4 and 14	2 2 0
R4E2	Tappet head, 2 off	35 4 and 14	2 2 0
R4E2	Tappet head lock nut, 2 off	35 4 and 14	2 2 0
R4E2	Tappet push rod covering tubes	35 12 and 22	2 2 0
R4E2	Idiot	35 16 and 26	2 2 0
R4E2	Small screws securing top end of above to rocker box		1 1 1
FE14	Rubber rings for bottom end of covering tubes	35 12, 15, 22, 26	3 3 3
FE14	Rubber rings for top end of tubes	35 12, 16, 22, 26	3 3 3
FE14	Tappet push rod with ends assembled with tappet adjusting screw and lock nut	35 12 and 22	4 1 3
20813 1	Idiot	35 16 and 26	4 1 3
FE14	Tappet push rod only, less ends	35 12 and 22	1 2 2
20818	Tappet push rod only, less ends	35 16 and 26	1 2 2
VE70	Tappet push rod hardened steel ball end, bottom	35 12, 16, 22, 26	1 0 0
FE14	Tappet push rod end or sleeve nut, top	35 12, 16, 22, 26	1 0 0
FE14	Tappet adjusting screw or bolt	35 12, 16, 22, 26	1 0 0
FE14	Lock nut for above	35 12, 16, 22, 26	4 4 4

V.

R3E4 6	Valve, inlet or exhaust	35 12 and 22	7 6 6
TE3 5 8	Valve guide	35 12 and 26	7 6 6
TE3 6 8	Valve, exhaust	35 16 and 26	3 9 9
D5E12 6	Valve, inlet or exhaust	35 4 and 14	3 9 9
R3E4 6 A	Valve complete with springs, collars and guide, inlet or exhaust	35 12 and 22	11 9 9
TE3 5 8 A	Idiot	35 16 and 26	10 11 1
TE3 6 8 A	Idiot	35 16 and 26	11 9 9
D5E12 6 A	Valve, inlet or exhaust	35 4 and 14	7 11 1
VE12 1	Valve spring, outer	35 12, 16, 22, 26	1 0 0
VE12 1	Valve spring, inner	35 12, 16, 22, 26	1 0 0
VE12 1	Valve spring	35 4 and 14	1 0 0
VE12 1	Valve spring top collar	35 12, 16, 22, 26	1 2 2
VE12 1	Valve spring seat, bottom (exhaust only)	35 12, 16, 22, 26	10 10 10
VE12 1	Valve spring collar, tappet end	35 4 and 14	6 6 6
VE12 1	Valve spring seat	35 4 and 14	6 6 6
VE12 1	Valve taper collars, 2 pieces	35 12, 16, 22, 26	9 9 9
R4E2	Metal washers for valve guide	35 4 and 14	4 4 4
L3E25 0	Valve cutter	35 4 and 14	3 3 3
LE148-8	Valve guide	35 12, 16, 22, 26	2 3 3
AC48	Valve guide	35 4 and 14	2 3 3
LE148-8	Valve stem hardened steel end caps	35 12, 16, 22, 26	3 7 7
D5E12 6	Valve lifter collar for exhaust tappet body	All models	1 0 0
D5E12 6	Valve lifter lever	All models	3 6 6
D5E12 6	Valve lifter spring	All models	3 3 3
D5E12 6	Valve lifter cross-head	All models	9 9 9
ST14	Lock nut for above	All models	2 2 2
VE12	Valve lifter cable complete assembled, 3/24"	All models	3 6 6
VE12	Valve lifter cable outer case, 2/10"	All models	2 0 0
VE12	Valve lifter cable inner wire, 3/24"	All models	2 9 9
VE12	Nipple for inner wire, each end	All models	1 1 1
3865	Valve lifter cable adjuster	35 12 and 16	5 5 5
H4E1	Valve lifter cable adjuster	35 4, 14, 22, 26	5 5 5
20813	Lock nut for above	35 12 and 16	4 4 4
20813	Lock nut for above	35 4, 14, 22, 26	4 4 4
HE36 A	Cable armour	35 4 and 14	3 3 3

NOTE.—There is no Valve Spring Bottom Seat fitted on the Inlet Valves of Models 35/12, 16, 22, 26.

Part No.	Description.	Models.	Price Each.
			£ s. d.
33M	Contact breaker bakelite cover complete with condenser	35 4, 12, 16	5 0 0
9M	Spring post retaining bakelite contact breaker cover	35 4, 12, 16	1 0 0
11M	Contact breaker cam	35 4, 12, 16	2 6 6
12M	Screw securing above cam	35 4, 12, 16	3 3 3
12A1M	Spring washer for above	35 4, 12, 16	1 1 1
10M	Contact breaker base assembled with points	35 4, 12, 16	7 6 6
19M	Fixing screw for above with spring	35 4, 12, 16	3 2 2
13M	Contact point or screw with rocker arm	35 4, 12, 16	3 6 6
14M	Contact breaker screwed contact	35 4, 12, 16	2 0 0
16'1	Ignition control cable complete, 3/7"	35 4, 12, 16	3 9 9
16'2	Ignition control outer casing only, 3/3"	35 4, 12, 16	1 8 8
16'3	Ignition control inner wire with nipples, 3/7"	35 4, 12, 16	1 8 8
32M	Rubber, covering cable adjuster	35 4, 12, 16	8 8 8
17M	Spring for ignition control cable	35 4, 12, 16	4 4 4
15M	Toggle for ignition control cable	35 4, 12, 16	6 6 6
18M	Screwed gland nut for ignition control cable (screws in timing gear cover)	35 4, 12, 16	6 6 6
31M	Ignition control cable adjuster complete	35 4, 12, 16	3 6 6
HE36 A	Armouring for outer case	35 4	3 3 3
221M	Ignition end	35 4, 12, 16	15 0 0
222M	Clip for above, complete with pinch bolt, spring washer and nut (sold complete)	35 4, 12, 16	0 0 0
166M	High tension cable complete with terminal end	35 4, 12, 16	1 0 0
173M	Terminal for above		3 3 3

IGNITION (35/14, 22, 26).

Part No.	Description.	Models.	Price Each.
			£ s. d.
35 22/E77	Magneto, Lucas M.C.1		4 0 0
35 22/E38	Magneto sprocket		3 6 6
35 22/E138	Sprocket for magneto chain drive, engine end		3 6 6
35 22/E76	Magneto platform		4 0 0
10318	Magneto base bolt (4 off)		4 4 4
35 22/E62	Magneto platform fixing bolt, short		4 4 4
ST14	Nuts for above		2 2 2
ST111	Washer for above		1 1 1
35 22/E51	Magneto platform bolt, long (low exhaust pipes only)		5 5 5
35 22/E55	Magneto platform distance piece, short (top left)		3 3 3
35 22/E53	Magneto platform distance piece, long (top right)		5 5 5
35 22/E54	Magneto platform distance piece, medium (bottom right)		4 4 4
DE15	Magneto platform bolt, long (high exhaust pipes only)		5 5 5
35 22/E200	Magneto shield		3 6 6
4284	Magneto shield H.T. cable bush		4 4 4
M71A	Magneto control cable complete, 3'		3 3 3
M72	Magneto control outer cable, 2'8 1/2"		2 0 0
M73	Magneto control inner wire with nipples, 3'		0 0 0
M74	Brass toggle for inner wire		6 6 6
M75	Spring for inner wire		2 2 2
M76	Control cable sleeve, fitted to magneto		6 6 6
M77	Magneto control cable adjuster		4 4 4
M78	Nut for above		1 1 1
M79	Gland rubber for above		3 3 3
HE36 A	Armouring for magneto control cable outer casing		3 3 3

EXHAUST PIPES.

Part No.	Description.	Models.	Price Each.
			£ s. d.
20850	Exhaust pipe only	35 4	1 0 0
35 14 E4/2	Exhaust pipe only	35 14	1 0 0
20802	Exhaust pipe only, low	35 12	18 6
20803	Exhaust pipe only, low	35 16	18 6
20802	Exhaust pipe only, low right	35 12	18 6
35 22 E401	Exhaust pipe only, low left	35 22	18 6

Always quote both Engine and Frame Numbers when ordering Spare Parts.

Part No.	Description.	Models.	Price Each.
20803	Exhaust pipe only, low right	35/26	18 6
35 26E401	Exhaust pipe only, low left	35 26	18 6
20872	Exhaust pipe only, high	35/12	1 8 6
20873	Exhaust pipe only, high	33/16	1 8 6
35 26E422	Exhaust pipe only, high right	35/22	1 8 6
35 22E421	Exhaust pipe only, high left	35/22	1 8 6
35 26E422	Exhaust pipe only, high right	35/26	1 8 6
35 26E421	Exhaust pipe only, high left	35/26	1 8 6
17480	Silencer (for high or low pipes)	All models	17 6
20867/1	Clip supporting rear end of silencer, low	35/4, 12, 14, 16	1 6
20867/1	Clip supporting rear end of silencer, low (2 off)	35, 22 and 26	1 6
D8E862A	Clip supporting rear end of silencer, high	35, 12 and 16	1 6
10921	Clip supporting rear end of silencer, high (2 off)	35, 22 and 26	1 6
55 22/E567	Tail pipe clip stay, high pipes only (2 off)	35, 22 and 26	1 6
2752	Pinch bolt for above, high or low exhaust pipes	All models	3
10499	Nut for above	All models	2
2886	Washers for above	All models	1
LF32	Bolt securing above clip to frame, low pipes	All models	3
STD4	Nut for above	All models	2
R2F250	Washer for above	All models	1
LF106	Bolt securing above silencer clip to mudguard arch assembly, low, high pipes only	35 12, 16, 22, 26	4
STD4	Nuts for above bolt	35 12, 16, 22, 26	2
R2F250	Washers for above	35 12, 16, 22, 26	1
10676	Front silencer clip, high and low pipes	All models	3
2751	Pinch bolt for above, low pipes	All models	3
10499	Nut for above	35 22 and 26	3
2752	Pinch bolt for above, high pipes	All models	1
2886	Washer for above bolt	35 22 and 26	1 6
35 22 E457	Silencer clip front star, high pipes	35 22 and 25	1 6
HRD36	Saddle spring bolt, high pipes only	35 12 and 16	4
AGL3	Front exhaust pipe clip bolt, high pipes	35 12, 16, 22, 26	2
STD4	Nuts for above	35 12, 16, 22, 26	4
STD11	Washers for above	35 12 and 16	3
L1117	Distance piece for above bolt, high pipes	35 12 and 16	1 6
R2F250	Packing washer, high pipes	35 12, 16, 22, 26	1 6
20860	Front exhaust pipe strap	35 4	1 6
35 26E401R	Front exhaust pipe strap, right	35 14	1 6
20568	Front exhaust pipe strap, low pipe	35 16	1 6
20377	Front exhaust pipe strap, low pipe	35 22	1 6
20377	Front exhaust pipe strap, left, low pipe	35 22	1 6
166-5	Front exhaust pipe strap, right, low pipe	35 26	1 6
35 26E401R	Front exhaust pipe strap, right, low pipe	35 26	1 6
20378	Front exhaust pipe strap, high pipe	35 12	1 6
20874	Front exhaust pipe strap, high pipe	35 16	1 6
20878	Front exhaust pipe strap, left, high pipe	35 22	1 6
10921	Front exhaust pipe clip, left, high pipe	35 22 and 26	1 6
BC0	Front exhaust pipe clip stay, right, high pipes	35 22 and 26	1 6
20766K	Exhaust pipe clip to stay distance piece	35 22 and 26	5
2751	Bolt for front exhaust pipe clip, right, high pipes	35 22 and 26	3
10499	Nut for above	35 22 and 26	2
2886	Washer for above	35 22 and 26	1

## ENGINE PLATES AND BOLTS.

Part No.	Description.	Models.	Price Each.
20780	Engine plates (2 off)	35 12, 16, 22, 26	4 0
20845	Engine plates (2 off)	35 4 and 14	4 0
HE18	Top front engine pinch bolt, 3 1/8" long	All models	1 6
STD4	Nuts for above	All models	2
LE15	Bolts securing rear engine plates to crankcase, 5 off, 3 1/8" long	All models	3
STD4	Nuts for above	All models	2
T5R1073	Bottom front engine fixing bolt, 5 1/8" long	All models	4
STD4	Nuts for above	All models	2
LE15	Front engine fixing bolts, 5 1/8" long	All models	3
HE17	Front engine fixing bolts, 5 1/8" long	All models	2
STD4	Nuts for above two bolts	All models	2
STD11	Washers for above bolts	All models	3
RF50	Rear engine lug bolt, 3 1/8" long	All models	1
STD3	Nuts for above	All models	3
HE18	Rear engine top bolt, 3 1/8" long	All models	5
STD4	Nuts for above	All models	2

Always quote both Engine and Frame Numbers when ordering Spare Parts.

## FRAME.

Part No.	Description.	Models.	Price Each.
20775	Front portion of main frame	All models	2 15 0
20776	Rear portion of main frame	All models	2 5 0
LF40	Rear chain adjuster screws (2)	All models	9
STD5	Lock nuts for above (2)	All models	2
RF40	Distance collar for above (2)	All models	2
FF323	Seat lug bolt, carries earth wire terminal (1 1/2" diameter)	All models	9
DF123	Seat lug bolt, carries earth wire terminal (1 1/2" diameter)	All models	6
STD1	Nuts for above, 1"	All models	4
2880	Washers for above, 1"	All models	1
STD4	Nuts for above, 3/16"	All models	2
STD11	Washers for above, 3/16"	All models	1
STD79	Nut securing earth wire terminal to above bolt	35-4, 12, 16	1
20860	Steady rod for cylinder head	35 12, 16, 22, 26	1 3
V2H17	Bolt for above	35 12, 16, 22, 26	2
STD4	Nut for above	35 12, 16, 22, 26	3
STD11	Washer for above	35 12, 16, 22, 26	1

## FRONT STAND.

Part No.	Description.	Models.	Price Each.
TFP67	Front stand	All models	5 0
11842	Front stand fixing pin to fork girder (2)	All models	3
STD74	Nut for above	All models	2
RM31	Front stand fixing pin to mudguard	All models	3
STD12	Plain washers for above (3)	All models	1
STD5	Nuts for above (2)	All models	2

## PROP STAND.

Part No.	Description.	Models.	Price Each.
D5F844	Centre nr prop stand	All models	12 6
D5F812	Fixing bolt for above, 4 1/8" long	All models	4
20766	Distance piece, 2 1/2" long	All models	4
STD4	End nuts for above (2 off)	All models	2
D5F2847	Flanged bushes for prop stand (2)	All models	6
HT6	Double spring washer for fixing bolt	All models	2
R2F250	Plain metal washer to fixing bolt	All models	1
D5F2845	Prop stand pull up spring (2 off)	All models	5

## MUDGUARDS (Front and Rear) AND NUMBER PLATES.

Part No.	Description.	Models.	Price Each.
20765	Front mudguard only	All models	10 0
FM50	Front mudguard stays (2)	All models	3
STD70	Bolts fixing top end of mudguard stays to mudguard	All models	1
2885	Spring washer for above	All models	3
STD12	Plain metal washer for above	All models	1
STD5	Nuts for above	All models	2
LF32	Bolt fixing bottom end of mudguard stay to fork girder (2 off)	All models	3
29768	Distance piece for above	All models	2
STD11	Plain metal washer for above	All models	1
110-25	Front number plate	All models	1 6
16905	Fixing screw for above	All models	3
3901	Nuts for above	All models	2
3901-N	Plain washers for above	All models	1
3901-N	Nuts for above	All models	4
1787	Rear mudguard complete (2 halves)	All models	18 0
1787F	Front portion of rear mudguard	All models	15 6
1787R	Rear portion of rear mudguard	All models	4 6
RF31	Bolt securing bottom end of front portion	All models	3
2885	Washer for above	All models	1
STD5	Nut for above	All models	2
TF71	Bolt securing top end of front portion to frame 1 1/8" under head	All models	3
STD5	Nut for above	All models	2
2885	Washer for above	All models	1

Always quote both Engine and Frame Numbers when ordering Spare Parts.

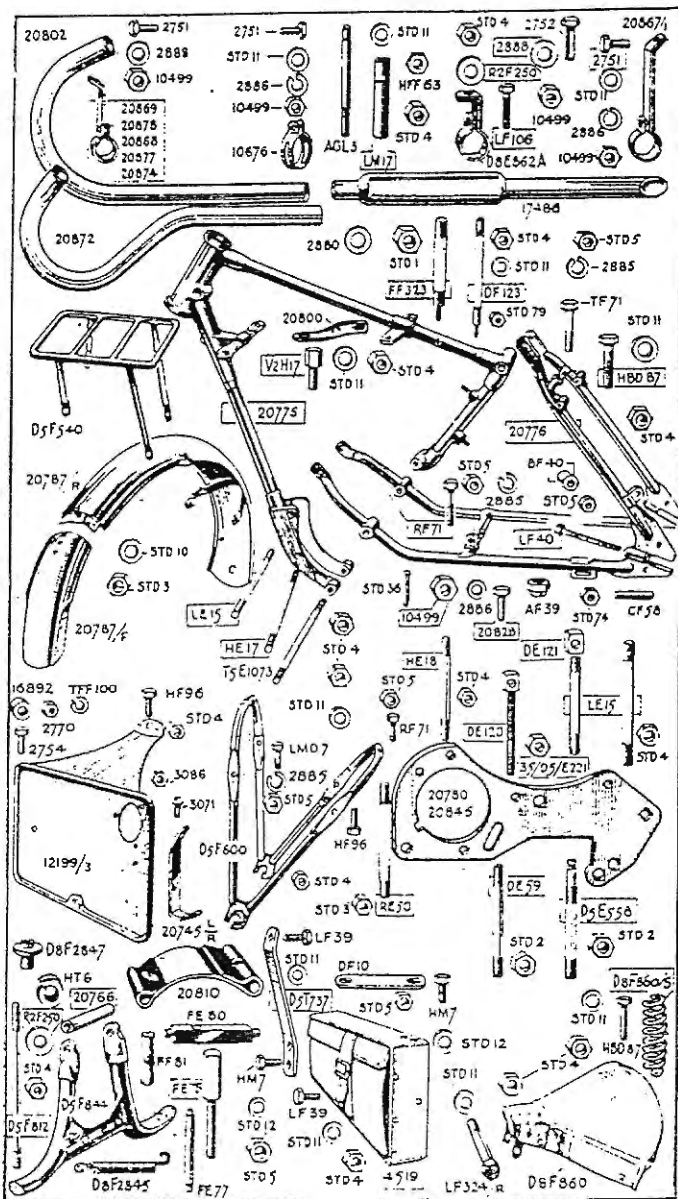

Part No.	Description.	Models.	Price Each.
			£ s. d.
STD3	Nut for mudguard joint stud	All models	3
STD10	Washer for above	All models	3
D5F600	Rear mudguard arch assembly	All models	13 6
CF58	Stud for bottom end of above, screws in frame (2 off)	All models	2
STD74	Inside lock nut for above	All models	2
AF59	Spigoted nut for above stud	All models	3
LMD7	Bolt securing top of arch assembly to mudguard	All models	1 2
2885	Spring washer for above	All models	2
STD5	Nut for above	All models	4
HF96	Bolt securing rear of arch assembly to mudguard	All models	2
STD4	Nuts for above	All models	5
HM3	Bolt securing rear of arch assembly to mudguard bridge (when low exhaust pipes fitted)	All models	2
STD4	Nuts for above	All models	1
STD11	Washer for above	All models	4
LF106	Bolt securing rear of arch assembly to mudguard bridge (when carrier fitted)	All models	2
STD4	Nuts for above (2 off)	All models	1
STD11	Washers for above	All models	4
LF106	Outside bolt securing rear of arch assembly to mudguard bridge (when high exhaust pipe fitted)	35 12. 16. 22. 26	2
STD4	Nuts for above	35 12. 16. 22. 26	1
STD11	Washers for above	35 12. 16. 22. 26	4
LF106	Outside bolt securing rear arch assembly to mudguard bridge (when high exhaust pipes and carrier fitted)	35 12. 16. 22. 26	3 6
STD74	Nut for outside bolt securing rear arch assembly, etc.	35 12. 16. 22. 26	4
12199 3	Rear number plate	All models	3 6
HF96	Bolt securing top of rear number plate to mudguard and arch assembly	All models	4
STD4	Nut for above	All models	3
2754	Bolt securing bottom of number plate to mudguard	All models	2
16892	Distance collar for above	All models	1 1
TFP160	Washer for above	All models	2 2
2770	Nut for above bolt	All models	4 1
20745 R	Number plate stay, right-hand or off side	All models	4 1
20745 L	Number plate stay, left-hand or near side	All models	2
3071	Screws for above (4 off)	All models	1
3086	Nuts for above (4 off)	All models	2
2885	Spring washer for bolt securing bottom of number plate	All models	1

## REAR CARRIER.

Part No.	Description.	Models.	Price Each.
			£ s. d.
D5F540	Carrier	All models	13 6
LMD7	Front fixing bolt (2 off)	All models	3 6
STD5	Nut for above (2 off)	All models	1
STD12	Washer for above (2 off)	All models	5
HM3	Rear fixing bolt (2 off) with low exhaust pipes	All models	2
STD4	Nuts for above (2 off) with low exhaust pipes	All models	1
STD11	Washers for above (2 off) with low exhaust pipes	All models	1

## SADDLE AND PARTS (35/4, 12, 14, 16, 22, 26).

Part No.	Description.	Models.	Price Each.
			£ s. d.
D8F860	Saddle top, complete assembled (Lycett)		1 0 9
D8F860 S	Saddle coil spring		5
HBD87	Bolt fixing bottom end of saddle spring (1 1/2" long under head)		3 6
STD4	Nut for above		1 1
STD11	Washer for above		3 6
LF324 R	Saddle nose bolt		1
STD4	Nut for above		1
STD11	Washer for above		4 4
AGL3	Stud fixing off-side saddle spring bottom end (when high exhaust pipe fitted) 4 1/2" long		2 2
LM17	Distance piece for above (2 1/8" long)		2 2
STD4	Nut for above (inside)		1
RF763	Nut for above (outside)		1
STD11	Washer for above		

Always quote both Engine and Frame Numbers when ordering Spare Parts.

# DYNAMO AND PARTS (35/4, 12, 14, 16, 22, 26).

Part No.	Description.	Models.	Price Each.		
			£	s.	d.
200.171	Lucas dynamo. E5A M04 0	35 14, 22, 26	10	0	0
DM3T	Miller dynamo	35 12, 16, 4	2	0	0
208e2	Dynamo chain sprocket	All models	3	6	3
DF187	Washers for dynamo shaft	All models	2	1	1
DF188	Locking washer for sprocket nut	All models	2	1	1
20865	Plain spring washer for above	All models	6	2	2
FE181	Sprocket lock nut	All models	2	1	1
FE182	Securing pin, dynamo to plate	All models	1	9	9
STD12	Washer for above	All models	1	5	5
FE190	Locating plate for dynamo	All models	1	0	0
36	Main brush for dynamo	35 4, 12, 16	1	5	5
37	Regulating brush for dynamo	35 4, 12, 16	1	0	0
34	Main brush holder	35 4, 12, 16	1	4	4
34A	Regulating brush holder	35 4, 12, 16	1	4	4
35	Brush holder spring	35 4, 12, 16	1	2	2
36	Cable plug for lighting cables	35 4, 12, 16	1	6	6
21-810	Strap securing dynamo	All models	1	6	1
FE188	Round cross bar for above	All models	1	0	0
FE189	Square cross bar for above	All models	1	0	0
FE175	Long hexagon-headed bolt, passes through above	All models	8	5	5
FE81	Round collar for above bolt	All models	1	0	0
200.025	Dynamo commutator strap	35 14, 22, 26	1	0	0
L.13+4 26	Pinch screw for above	35 14, 22, 26	2	2	2
200.027	Dynamo brushes (set of 3)	35 14, 22, 26	3	0	0

# HANDLEBAR GROUP (35/4, 12, 14, 16, 22, 26).

Part No.	Description.	Models.	Price Each.		
			£	s.	d.
12346 AN	Handlebar, complete assembled with levers, twist grip, horn switch cable, dipping switch cable, less control cables		3	0	0
12349	Handlebars, bare, less all fittings		1	1	0
H3275	Locating ring for twist grip and dummy grip		1	0	1
H3273	Grip screw for above		1	1	1
H3347	Shim washer for twist and dummy grip (4)		3	1	1
H3478	Twist grip sleeve with rubber only		5	0	0
H3297	Twist grip and dummy grip rubber only		1	2	2
H3462	Dummy grip sleeve and rubber		1	2	2
H3288	Cap washer for inner ends of grips		1	1	1
H3471	End plug for handlebar		1	1	1
H3292	Screw securing above		1	1	1
H3284	Twist grip and dummy grip outer end cap		1	1	1
H2-14	Fixing bolt for above		1	5	2
H3481	Plain metal washer for end plug		2	0	0
H334	Double spring washer for end plug twist grip end only		2	0	0
H3444	Twist grip inner slider		2	0	0
H3287	Twist grip outer slider		9	0	0
H3502	Screw for above securing nipple or outer cap		1	0	0
H3276	Clutch lever		1	0	0
H3485	Ignition lever		1	0	0
H3486	Air lever		1	0	0
H3267	Front brake lever		1	0	0
H3395	Exhaust litter lever		2	0	0
H3282	Eburnum screw for above		2	0	0
H8	Nut for above		3	0	0
H3266	Plate separating levers		3	0	0
H3276	Bush for ignition and air lever		3	0	0
H3464	Bush for clutch and front brake lever		3	0	0
H3467	Long aluminium screw for levers, 1" under head		3	0	0
H3315	Double spring washer for above		1	1	1
H731	Plain metal washer for above		1	1	1
H3484	Collar nut for above		3	0	0
H8	Lock nut for above		3	0	0
H3506	Horn switch knurled chromite ring		2	0	0
H3469	Knurled switch knurled chromite ring		2	0	0
H3768	Electric push button		6	6	6
H3461	Electric contact block for horn switch		1	0	0
H3464	Electric contact block for dipping switch		2	0	0
H3271	Revolving nipple for clutch and front brake levers		3	0	0
H3274	Adapter for front brake control outer casing		3	0	0
H3487	Adapter for air control outer casing		3	0	0
H3275	Adapter for clutch control outer casing		3	0	0
H3488	Adapter for ignition control outer casing		3	0	0
R3287	Adapter for exhaust litter control outer casing		3	0	0
35 4, 12, 16	Dipping switch cable only		1	0	0
35 4, 12, 16	Horn switch cable only		1	0	0

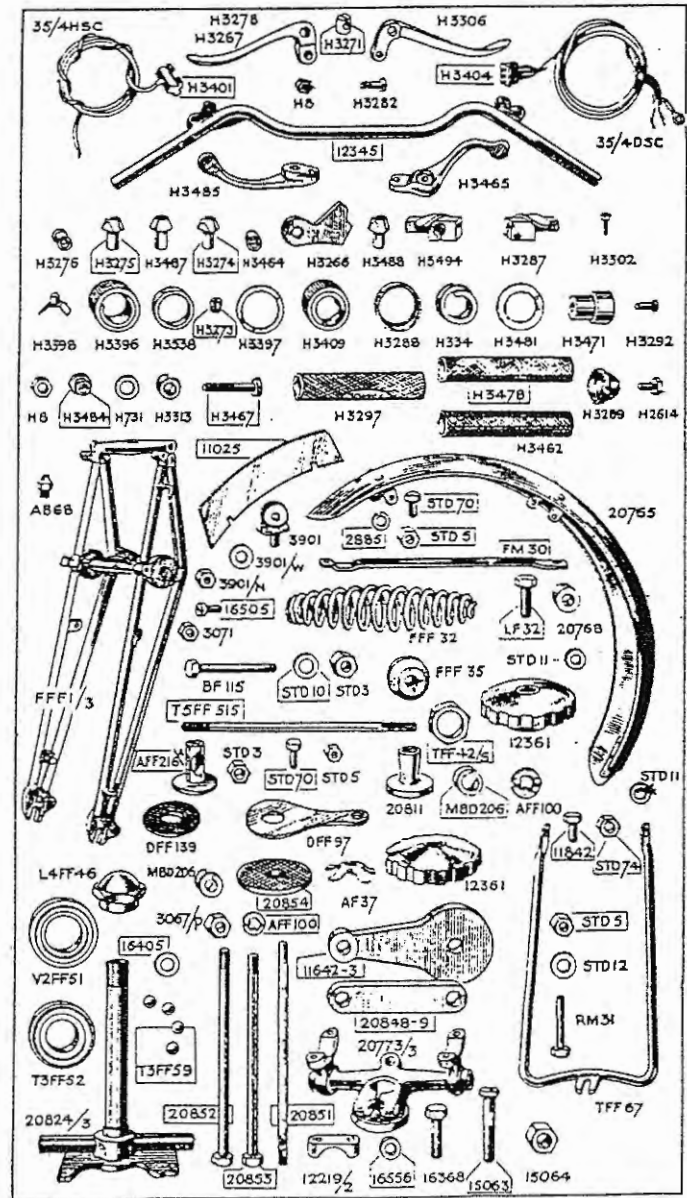

Always quote both Engine and Frame Numbers when ordering Spare Parts.

## FORK GROUP.

Part No.	Description.	Models.	Price Each.
FFF1 5A	Front forks complete assembled with crown and stem, links, fork spindles, spring, damper, etc. less mudguard and stand	All models (except 35 12)	6 0 0
FFF1 5A 12	Front forks complete assembled with crown and stem, links, spindles, spring, etc. but less damper, also less mudguard and stand	35 12	6 12 6
FFF1 5	Front fork zinder only	All models	2 12 0
AD68	Front fork zinder grease nipple	All models	2 2
2 824 5	Front fork crown and stem	All models	15 0
20775 5	Head clip	All models	8 6
AB48	Head clip grease nipple	All models	1 6
12216 2	Handlebar clip (2 off)	All models	1 6
16556	Bolt securing above to head clip (4 off)	All models	1 1
16556	Plain washer for above (4 off)	All models	1 1
15665	Pinch pin for fork head clip	All models	5 5
15664	Nut for above	All models	5 5
FFF32	Front fork spring	All models	3 0
BF115	Bolt securing above to head clip	All models	3 3
STD10	Plain washer for above	All models	1 1
STD3	Nut for above	All models	3 3
FFF35	Distance piece for above long bolt	All models	3 3
2VF51	Steering head frame race (3 off)	All models	2 5
T3FF72	Fork crown ball race	All models	3 2
T3FF59	Set of balls for above	All models	1 2
12561	Adjusting nut for steering head	All models (except 35 12)	1 8
L4FF46	Domed adjusting nut for steering head	35 12	1 6
20855	Front fork spindle, top front or rear (5 51 22" long under head)	All models	1 5
20851	Front fork spindle, bottom front	All models	1 6
20852	Front fork spindle, bottom rear (7 3/8" long under head)	All models	1 6
3 67 P	Lock nut for spindles (4 off)	All models	3 3
15405	Front fork spindle washer, thin (4)	All models	1 1
20846	Left-side top front fork link, threaded hole	All models	1 6
20848	Right-side top front fork link, plain hole	All models	1 3
11642	Left-side bottom fork link, threaded hole	All models	1 0
11543	Right-side bottom fork link, plain hole	All models	1 6
20854	Front fork damper ferodo friction disc	All models	6 8
AF57	Front fork damper star spring washer	All models	6 6
MRD206	Double spring washer for above	All models	3 3
AF111	Batchet washer for above	All models	3 3
12561	Front fork damper hand adjusting knob	All models	1 5

### STEERING DAMPER (All Models except 35/12).

Part No.	Description.	Models.	Price Each.
12561	Steering damper chrome knob		1 6
TFF42 8	Steering crown lock pin		9 9
AF111	Batchet washer for spring damper rod		3 3
MRD206	Spring washer for steering damper rod		2 2
20811	Plated distance piece for steering damper rod		1 3
T5FF515	Steering damper rod		8 8
STD5	Nut for steering damper rod		5 5
AF1216-A	Steering damper base		1 0
DFF139	Fibre washer for steering damper base (2)		3 3
DFF97	Steering damper anchor plate (2)		3 3
STD70	Fixing pin for steering damper anchor plate (2)		3 3
STD5	Nut for above (2)		2 2

### TOOLBAG, TOOLS, TOOLBOX AND FITTINGS.

Part No.	Description.	Models.	Price Each.
17520A	Toolbag complete with tools	All models	1 5 0
17520	Toolbag only	All models	1 6 0
5251	Large open-ended spanner (3 3/4")	All models	1 6
3362	Medium open-ended spanner (3 1/8")	All models	1 3
3265	Small open-ended spanner (3 7/8")	All models	1 0
3270	Pair pliers	All models	2 0
LTK20	Grease gun	All models	4 0
LTK14	Tyre lever	All models	3 3
LTK15	Screwdriver	All models	4 4
LTK12	Adjustable spanner	All models	4 0
11024	Pair sidecut pin circlip pliers	All models	6 6

Always quote both Engine and Frame Numbers when ordering Spare Parts.

Part No.	Description.	Models.	Price Each.
35 12TK1	Spanner for coil ignition set	35 12, 16, 4	6 6
35 12TK2	Spanner for Lucas dynamo set	35 22, 26, 14	4 4
(TK9)	Tapet adjusting spanner	All models	9 9
BFK1	Plug spanner with tommy bar	35 4 and 14	9 9
17521	Tyre pump	All models	3 9
4519	Toolbox only	All models	5 6
LF39	Bolt securing bottom of toolbox to frame	All models	3 3
STD4	Nut for above	All models	2 2
STD11	Washer for above	All models	1 1
D5T737	Strap from toolbox to oil tank	All models	6 6
LF39	Bolt securing above to oil tank	All models	3 3
STD11	Washer for above	All models	1 1
HM7	Bolts securing above strap to toolbox	All models	3 3
STD5	Nuts for above	All models	2 2
STD12	Washers for above	All models	2 2
DF10	Stay or strap from toolbox to mudguard	All models	3 3
HM7	Bolts for above (either end)	All models	4 4
STD5	Nuts for above	All models	4 4
STD12	Washers for above	All models	1 1

### PETROL TANK AND FITTINGS, AND PETROL PIPES.

Part No.	Description.	Models.	Price Each.
20779	Petrol tank less all fittings, for foot gear change	All models	3 10 0
20799-2	Petrol tank less all fittings, for hand gear change	35 4 and 14	3 15 0
20799	Petrol tank less all fittings, for hand gear change	35 12, 16, 22, 26	3 15 0
P43	Petrol tank filler cap	All models	2 9
16417/1	Petrol tank fixing bolt	All models	2 2
16413	Petrol tank fixing bolt rubber pad, thick	All models	2 2
16414	Petrol tank fixing bolt rubber pad, thin	All models	2 2
RT17	Metal washer for petrol tank fixing bolt	All models	3 0
5538/B	Petrol tap	All models	2 2
11504	Fibre washer for above, thick	All models	2 2
11503	Fibre washer for above, thin	All models	2 2
12241/1	"U" pipe connecting two halves of petrol tank, assembled with banjo unions	All models	4 0
16190	Banjo union only, for above	All models	8 8
35 G3/T24	Banjo union pin or bolt, with gauge	All models	1 9
11504	Thick fibre washer for above (2)	All models	2 2
11503	Thin fibre washer for above	All models	2 2
20855/1	Petrol supply pipe assembled with unions and nuts	35 4 and 14	3 9
20805/1	Petrol supply pipe assembled with unions and nuts	35 12 and 22	3 9
20806/1	Petrol supply pipe assembled with unions and nuts	35 15 and 26	3 9
5N5	Union for above		4 4
DT4/L	Left-side kneeclip	All models	2 6
DT4/R	Right-side kneeclip	All models	2 6
4307	Kneeclip fixing plate	All models	6 6
11741	Screw securing above	All models	2 2

### OIL TANK WITH FITTINGS AND OIL PIPES.

Part No.	Description.	Models.	Price Each.
D5T745	Oil tank less all fittings	All models	18 6
6901L	Oil tank filler cap	All models	5 0
STD4	Nut securing oil tank to frame (2)	All models	2 2
STD11	Plain metal washer (6ts under above nuts)	All models	1 1
D5T511	Oil tank felt cartridge filter	All models	2 6
D5T577	Chromium-plated hexagonal cap for above	All models	1 6
D5T572	Cork washer for above cap	All models	2 2
D5T573	Recessed washer for felt filter	All models	3 3
D5T576	Small spring for above	All models	4 4
AT87	Brass gauge for oil tank	All models	8 8
D5T737	Oil tank securing strap	All models	6 6
LF39	Bolt securing above to tank	All models	3 3
HM7	Bolt securing above strap to toolbox (2 off)	All models	3 3
STD12	Plain metal washer for above (2 off)	All models	1 1
STD5	Nut for above (2 off)	All models	2 2
2VF2/1	Oil feed pipe	All models	3 6
2VF93/1	Oil return pipe	All models	3 6

Always quote both Engine and Frame Numbers when ordering Spare Parts.

## FOOTRESTS AND FITTINGS.

Part No.	Description.	Models.	Price Each.
20866	Footrest rod	All models	£ 5 3
4518	Footrest hanger, right or left side	All models	5 3
16315	Footrest rubber pad	All models	1 6
V2FR6	Footrest tube, 21" long (fits between engine plates)	All models	5
11457 1	Footrest tube, 15 3/8" long (2 off) (fits outside engine plate)	All models	4
2764	Footrest rod end nut (2 off)	All models	3
2381	Washer for above (2 off)	All models	1

## CHAINGUARDS AND FITTINGS.

Part No.	Description.	Models.	Price Each.
191810 A	Rear chain guard	All models	10 6
12327	Long hexagon-headed bolt securing front end	All models	1 1
2385	Spring washer for above	All models	1
LF39	Bolt securing rear end of chainguard to frame	All models	3
STD11	Washer for above	All models	1
STD70	Bolt securing bottom of chainguard extension to frame	All models	3
STD5	Nut for above	All models	2
TF100	Spring washer for above	All models	1
FC1 6	Front chainguard, back portion	All models	12 6
20817 1	Front chainguard, outer portion	All models	16 6
17285	Bolt securing back portion to crankcase (3 off)	All models	2
17286	Locking plate for above	All models	2
12302 7	Aluminium band clip for front chaincase	All models	5 0
12302 9	Rubber strip for above	All models	6
16450	Pinch screw for aluminium band clip	All models	2
17350 1	Front chaincase inspection cover complete assembled	All models	1 4
17350	Front chaincase inspection black enamel cover only	All models	4
17364	Cork washer for above	All models	2
17258	Fixing screw for front chainguard inspection cover	All models	6
17256	Fixing plate for front chaincase inspection cover	All models	4

## CHAINS.

Part No.	Description.	Models.	Price Each.
35 12/C13	Front chain, 1" x 3/65", 65 links	75 4, 12, 14, 22	£ 7 7
35 16/C13	Front chain, 1" x 3/65", 66 links	75 10 and 20	7 9
35 12/C14	Rear chain, 1" x 3/65", 115 links	75 12, 16, 22, 26	12 11
35 4/C14	Rear chain, 1" x 3/65", 114 links	75 4 and 14	13 1
35 22/E24	Magneto driving chain, 1" x 2/25", 42 links	75 22, 14, 25	3 4
75 12/E224	Dynamo chain, 1" x 2/25", 47 links	All models	5 6
LF40	Rear chain adjusting screw	All models	9
BF40	Distance collar for above	All models	2
STD5	Lock nuts for above screws	All models	2

## BURMAN GEAR BOX C.P. TYPE MARK VI.

Part No.	Description.	Models.	Price Each.
ICPM.VI.	Gear box shell	35 4 and 14	£ 1 8 0
3CM.V.	Gear box end plate (supplied only with studs)	35 4 and 14	15 0
4CM.IV.	Kickstarter case cover	35 4 and 14	12 6
155X	Large screwed plug (fits in kickstarter case)	35 4 and 14	1 0
69X	Gear box end plate studs screw in shell (5 off)	35 4 and 14	6
4 1C	Gear box end plate paper washer	35 4 and 14	1
128X	Studs securing grease cover (2 off)	75 4 and 14	6

Always quote both Engine and Frame Numbers when ordering Spare Parts.

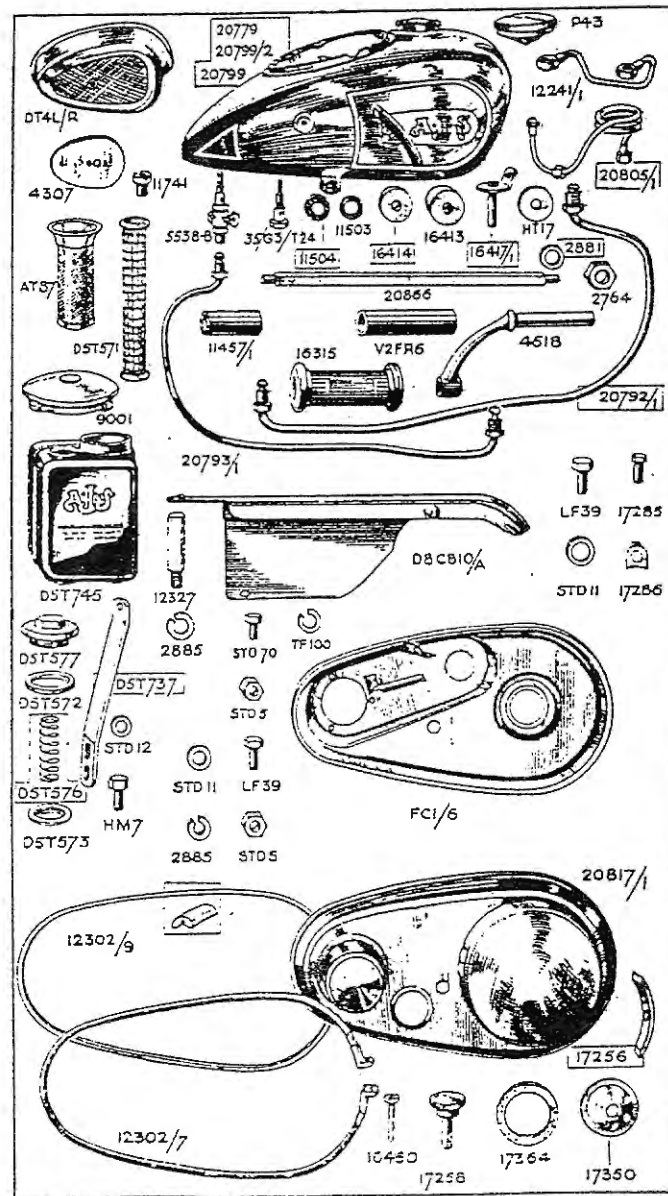

Part No.	Description.	Models.	Price Each.
63X	Nuts for above studs (7 off)	35 4 and 14	2
156X	Pin securing speedometer cable in end plate	35 4 and 14	1
188X	Inspection cover	35 4 and 14	3
152X	Nuts for kickstarter case cover studs, large (2 off)	35 4 and 14	1 0
63X	Nuts for kickstarter case cover studs, small (4 off)	35 4 and 14	2
245X	Grease nipple for kickstarter case cover (2 off)	35 4 and 14	2
157 VII.	H.S. or sleeve pinion with bushes, 36 teeth	35 4 and 14	15 0
187X M 111	Bronze bushes for above (2 off)	35 4 and 14	2 0
177X	Large journal bearing for sleeve pinion	35 4 and 14	15 0
75X	Oiled washer, butts against above	35 4 and 14	6
80X	Spring ring retaining washer	35 4 and 14	4
180X M. V.	Distance collar for sleeve pinion, 1" wide	35 4 and 14	1 0
180X	Thin washer for above	35 4 and 14	1 0
178X	Thin washer for above	35 4 and 14	1 0
179X M 5	Gear box sprocket, 22 teeth	35 4 and 14	15 0
176X	Nut securing above	35 4 and 14	1 9
30C M VIII.	Gear box layshaft	35 4 and 14	1 3 0
25C III.	Layshaft fixed pinion, 22 teeth	35 4 and 14	10 0
27C V.	Layshaft free pinion, 31 teeth	35 4 and 14	12 6
29C III.	Layshaft double sliding clutch	35 4 and 14	7 6
29C V.	Layshaft free pinion, 24 teeth	35 4 and 14	12 6
29C III.	Layshaft fixed pinion, 19 teeth	35 4 and 14	10 0
191X	Bronze bush for layshaft clutch end	35 4 and 14	4 0
182X	Steel end cup for above, presses in shell	35 4 and 14	3
181X	Bronze bush for layshaft kickstarter end	35 4 and 14	4 0
174X	Steel bush for sleeve, butts against above	35 4 and 14	1 0
10C XII.	Mainshaft	35 4 and 14	1 5 0
14C IV.	Mainshaft double sliding pinion, 23-18 teeth	35 4 and 14	1 10 0
24C M III.	Mainshaft free pinion, 27 teeth	35 4 and 14	12 6
68X	Journal bearing for mainshaft, kickstarter end	35 4 and 14	12 6
37 10	Steel washer for above	35 4 and 14	6 6
37 20	Spring ring retaining above	35 4 and 14	4
183X	Kickstarter ratchet pinion, 16 teeth	35 4 and 14	8 0
184X	Steel bush for above	35 4 and 14	2 6
186X	Kickstarter ratchet driver	35 4 and 14	5 9
185X	Spring, fits behind ratchet pinion	35 4 and 14	9
70X	Mainshaft end nut, retains ratchet driver	35 4 and 14	4
33C M III.	Speedometer driving worm shaft, 13 teeth	35 4 and 14	6 0
158X	Kickstarter axle or shaft, less quadrant	35 4 and 14	7 6
245X	Grease nipple for shaft	35 4 and 14	2 6
166X	Kickstarter quadrant only, 17 teeth	35 4 and 14	10 6
201X	Steel bush for kickstarter axle, fits in end plate	35 4 and 14	2 0
130X	Kickstarter crank return spring	35 4 and 14	2 0
134X	Kickstarter crank stop rubber	35 4 and 14	3
142X V	Kickstarter crank less pedal pin	35 4 and 14	7 6
115X	Ball pin for kickstarter crank	35 4 and 14	3 0
145X	Kickstarter cotter pin	35 4 and 14	3 0
147X	Kickstarter cotter pin washer	35 4 and 14	1 2
190	Kickstarter cotter pin nut	35 4 and 14	2
50C M II.	Gear selector camshaft	35 4 and 14	1 5 0
131X	Gear selector fork, large	35 4 and 14	8 0
42	Gear selector fork, small	35 4 and 14	8 0
157X	Guide pins for above (2 off)	35 4 and 14	6
158X	Split pins for above	35 4 and 14	1
159X	Steel bush for above camshaft, clutch end	35 4 and 14	2 0
162X	Rollers for camshaft, kickstarter end (2 to a set) per set	35 4 and 14	2 0
160X M II.	Steel bush for rollers, presses end plate	35 4 and 14	2 0
163X M II.	Locating pawl for gear selector camshaft	35 4 and 14	2 0
193X M I.	Spring for locating pawl for gear selector camshaft	35 4 and 14	9
69X	Scraper plug retaining spring	35 4 and 14	1 0
65X	Small nut retaining above pawl	35 4 and 14	4
161X	Gear selector quadrant complete	35 4 and 14	7 6
162X	Gear selector quadrant complete	35 4 and 14	7 6
166X M I.	Shaft for above	35 4 and 14	7 6
169X	Bronze bush for above, fits in kickstarter case	35 4 and 14	2 0
167X M III.	External gear operating lever	35 4 and 14	4 0
171X	Nut retaining above and selector to shaft (2 off) 1"x26	35 4 and 14	2
170X	Washers for above (2 off)	35 4 and 14	1

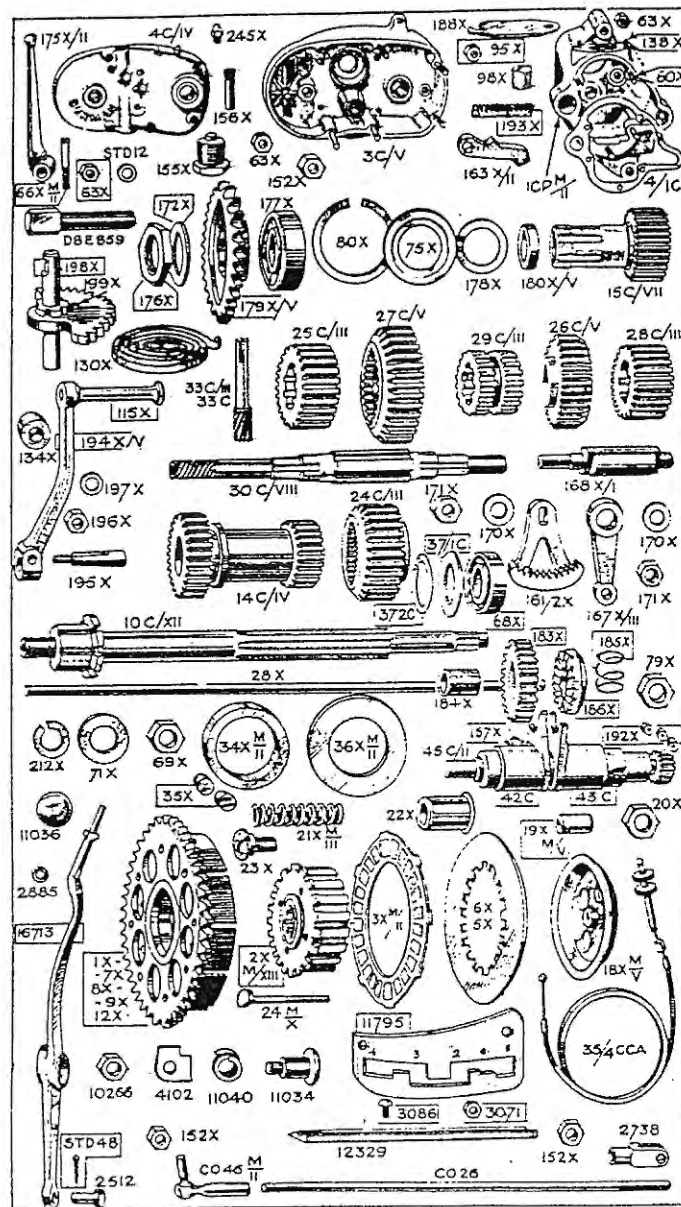

NOTE—It is advisable to quote gear box numbers when ordering. If not available quote horse-power and year of manufacture.

Always quote both Engine and Frame Numbers when ordering Spare Parts



## GEAR BOX FIXING GROUP.

Part No.	Description.	Models.	Price Each.
DF56	Top gear box fixing bolt	35 4 and 14	£ s. d. ..... 6
D5E358	Bottom gear box fixing bolt	35 4 and 14	..... 8
STD2	Nuts for above (3 off) standard type	35 4 and 14	..... 4
D8E856	Top gear box fixing bolt extended type	35 4 and 14	..... 8
DK121	Gear box eye adjusting bolt	35 4 and 14	..... 6
35 5 231	Nut for above	35 4 and 14	..... 2
DK121	Block for gear box adjuster, fits on engine plate	35 4 and 14	..... 4
LF36	Bolt securing above	35 4 and 14	..... 3
STD11	Washer for above	35 4 and 14	..... 1

## CLUTCH.

Part No.	Description.	Models.	Price Each.
1X, X-6X, 6X, 12X	Clutch sprocket assembled with driver, 40 teeth	35 4 and 14	£ s. d. ..... 1 16 8
2XM XII.	Clutch hub	35 4 and 14	..... 1 0 0
34XM II.	Centre steel sleeve for clutch hub bearing	35 4 and 14	..... 2 0 0
35XM II.	Large steel washer for clutch sprocket bearing (2 off)	35 4 and 14	..... 9
37X	Rollers for clutch sprocket bearing, 1" x 1" (per set of 24)	35 4 and 14	..... 3 6
66X	Nut retaining clutch hub	35 4 and 14	..... 6 6
71X	Plain metal washer for above	35 4 and 14	..... 2 2
212X	Spring washer for above	35 4 and 14	..... 3
3XM II.	Clutch friction plate with fibre inserts (4 off)	35 4 and 14	..... 5 0 0
6X	Thick plain metal clutch plate (1 off)	35 4 and 14	..... 2 0 0
5X	Thin plain metal clutch plate (4 off)	35 4 and 14	..... 2 0 0
22X	Outer clutch plate housing thimbles (4 off)	35 4 and 14	..... 6 6
18XM V.	Clutch spring plate	35 4 and 14	..... 9 0 0
41XM III.	Clutch spring (4 off)	35 4 and 14	..... 6 6
24XM X	Clutch spring studs (4 off)	35 4 and 14	..... 4
27X	Special duty spring adjuster nuts	35 4 and 14	..... 4 4
28X	Push rod (2)	35 4 and 14	..... 1 0 0
14XM V	Push rod adjusting screw, fits in clutch plate	35 4 and 14	..... 6 6
2 X	Lock nut for above	35 4 and 14	..... 2 0 0
175XM II.	Clutch operating lever	35 4 and 14	..... 2 0 0
20XM II.	Fulcrum screw for above	35 4 and 14	..... 2 0 0
53X	Lock nut for above	35 4 and 14	..... 2 2
8FD12	Washer for above	35 4 and 14	..... 2
35 20 X	Clutch cable complete assembled with adjuster	35 4 and 14	..... 4 6
35 20 X	Clutch outer case, 45"	35 4 and 14	..... 2 0
35 20 X	Clutch inner wire, 4 1/2"	35 4 and 14	..... 6 6
35 20 X	Handle for above, handbar end	35 4 and 14	..... 1
35 20 X	Handle for above, gear box end	35 4 and 14	..... 1
35 20 X	Clutch cable adjuster	35 4 and 14	..... 6 6
35 20 X	Lock nut for above	35 4 and 14	..... 2
35 20 X	Small sleeve, fits on end of adjuster and clutch outer casing	35 4 and 14	..... 3

## GEAR CHANGE PARTS.

Part No.	Description.	Models.	Price Each.
11795	Change speed gate	35 4 and 14	£ s. d. ..... 4 6
12320	Rubber strip for above	35 4 and 14	..... 3 6
3086	Screw securing gate to tank (2 off)	35 4 and 14	..... 2 2
5071	Nuts for above	35 4 and 14	..... 2 2
16713	Gear change lever	35 4 and 14	..... 7 6
11036	Gear lever knob	35 4 and 14	..... 10
2845	Spring washer for above	35 4 and 14	..... 1
11074	Gear lever fulcrum screw	35 4 and 14	..... 5
11040	Double spring washer for above	35 4 and 14	..... 4
10266	Nut for fulcrum screw	35 4 and 14	..... 4
4102	Locking washer for above	35 4 and 14	..... 3 3
0926	Gear rod - state length when ordering	35 4 and 14	..... 1
2738	Gear rod yoke end	35 4 and 14	..... 3 0
152X	Gear rod yoke end nut	35 4 and 14	..... 1 0 0
2512	Gear rod yoke end pin	35 4 and 14	..... 3 2
STD48	Split pin for above	35 4 and 14	..... 1
0926M II.	Bottom gear rod ball joint assembly	35 4 and 14	..... 1 6
152X	Lock nut for above	35 4 and 14	..... 3
	Nuts for threaded pin of ball joint assembly (2 off)	35 4 and 14	..... 3

Always quote both Engine and Frame Numbers when ordering Spare Parts.

## GEAR BOX PARTS (BURMAN 4-SPEED).

### SHELL GROUP.

Part No.	Description.	Models.	Price Each.
1HP/111	Gear box shell only	35 12. 16. 22. 26	£ s. d. ..... 1 5 0
2H	Gear box end plate	35 12. 16. 22. 26	..... 16 6 0
60X	Studs securing gear box end plate	35 12. 16. 22. 26	..... 2
63X	Nuts securing gear box end plate	35 12. 16. 22. 26	..... 6 6
71H	Grease cap or cover for gear box shell	35 12. 16. 22. 26	..... 1 6 6
138X	Studs securing grease cover	35 12. 16. 22. 26	..... 6 6
63X	Nuts securing grease cover	35 12. 16. 22. 26	..... 2

### FIXING BOLT GROUP.

Part No.	Description.	Models.	Price Each.
DE59	Top gear box fixing bolt	35 12. 16. 22. 26	£ s. d. ..... 6
D5E358	Bottom gear box fixing or pivot bolt	35 12. 16. 22. 26	..... 8
STD2	Nuts for above (4 off)	35 12. 16. 22. 26	..... 4
DE120	Gear box eye adjusting bolt	35 12. 16. 22. 26	..... 6
35/D5/E221	Nut for above (2 off)	35 12. 16. 22. 26	..... 2
DE121	Block for gear box adjuster (fits on engine fixing bolt)	35 12. 16. 22. 26	..... 4

### GEAR BOX BEARING GROUP.

Part No.	Description.	Models.	Price Each.
267X	Ball bearing (21"x7 1/8"x1 1/4") for high-speed sleeve pinion	35 12. 16. 22. 26	£ s. d. ..... 12 3
259X	Grease retaining washer for sleeve pinion bearing	35 12. 16. 22. 26	..... 4
78X	Spring ring retaining sleeve pinion bearing	35 12. 16. 22. 26	..... 4
260X	Shim washer (11 1/8"x1 1/8" hole) for sleeve pinion bearing	35 12. 16. 22. 26	..... 3
268X	Ball bearing in end plate (35 mm. x 11 mm. x 15 mm.)	35 12. 16. 22. 26	..... 11 0
255X	Bush for layshaft in gear box shell	35 12. 16. 22. 26	..... 3 0
255X	Bush for layshaft in end plate	35 12. 16. 22. 26	..... 3 0
254X	External washer for mainshaft bearing (1 1/8"x29/32" hole)	35 12. 16. 22. 26	..... 3
253X	Retaining spring ring for ball bearing in end plate	35 12. 16. 22. 26	..... 1 0

### GEAR AND SHAFT GROUP.

Part No.	Description.	Models.	Price Each.
11H/1	Mainshaft (101" long overall)	35 12. 16. 22. 26	£ s. d. ..... 1 5 0
29H	Layshaft (71" long overall)	35 12. 16. 22. 26	..... 1 5 0
15H	High-speed sleeve pinion with bushes (29 teeth)	35 12. 16. 22. 26	..... 1 12 6
14H	Mainshaft sliding gear wheel (23 and 26 teeth)	35 12. 16. 22. 26	..... 1 5 0
25W	Mainshaft low gear pinion with collar (17 teeth)	35 12. 16. 22. 26	..... 12 0
28H	Layshaft low gear pinion (32 teeth)	35 12. 16. 22. 26	..... 12 0
27H	Layshaft sliding pinion (23 teeth)	35 12. 16. 22. 26	..... 17 6
26H	Layshaft sliding pinion (23 teeth)	35 12. 16. 22. 26	..... 17 6
25H	Layshaft high gear pinion (23 teeth)	35 12. 16. 22. 26	..... 10 0

Always quote both Engine and Frame Numbers when ordering Spare Parts.

## GEAR OPERATING GROUP (Internal).

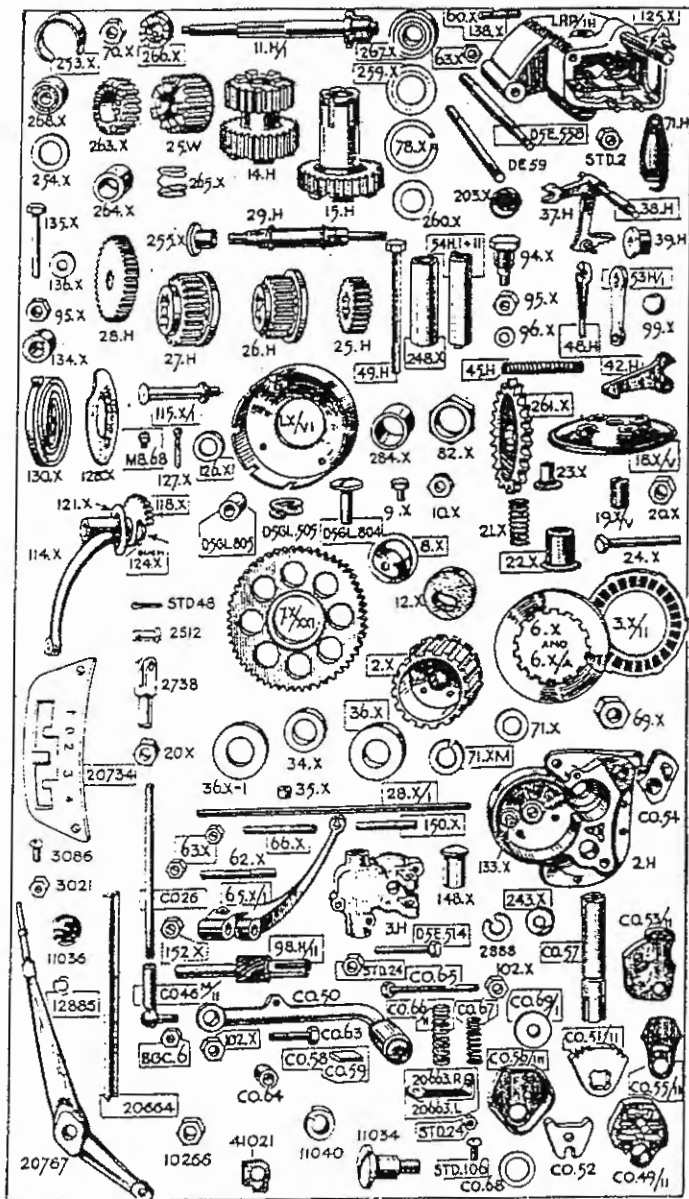

Part No.	Description.	Models.	Price Each.
			£ s. d.
37H	Gear changing bell crank, less spindle .....	35 12. 16. 22. 26	8 6
39H	Bush for gear change bell crank (screws in shell) .....	35 12. 16. 22. 26	1 0
48H	Gear operating lever (inside box) .....	35 12. 16. 22. 26	4 0
99X	Ball for end of gear box operating lever .....	35 12. 16. 22. 26	1 6
54H 1 & 11	Hollow shaft for internal lever (hand change) .....	35 12. 16. 22. 26	4 0
(U57)	Hollow shaft for internal lever (foot change) .....	35 12. 16. 22. 26	5 0
248X	Steel bush for hollow shaft (hand change) fits in end plate .....	35 12. 16. 22. 26	3 0
38H	Bell crank spindle only .....	35 12. 16. 22. 26	2 6
(U57)	Steel bush for hollow shaft (foot change) fits in end plate .....	35 12. 16. 22. 26	5 0
53H.1	External gear change lever (fits on hollow shaft) .....	35 12. 16. 22. 26	2 6
49H	Bolt securing internal and external levers. 3 1/2" x 3/16" (hand change) .....	35 12. 16. 22. 26	1 0
(O65)	Bolt securing internal lever and foot change mechanism. 4 1/2" x 3/16" (foot change model only) .....	35 12. 16. 22. 26	1 3
243X	Lock washer for bolt head (inside box) .....	35 12. 16. 22. 26	1 2
2888	Spring washer for bolt, outside end .....	35 12. 16. 22. 26	1
(O69/1)	Large washer for bolt, outside end (foot change only) .....	35 12. 16. 22. 26	1
102X	Nut for bolt, outside end .....	35 12. 16. 22. 26	3 0
42H	Gear indexing lever or pawl .....	35 12. 16. 22. 26	2 0
94X	Bolt securing gear index pawl (screws in shell) .....	35 12. 16. 22. 26	1 3
95X	Nut for bolt securing gear index pawl .....	35 12. 16. 22. 26	3 0
96X	Washer for bolt securing gear index pawl .....	35 12. 16. 22. 26	1
203X	Cap for head of bolt supporting gear index pawl .....	35 12. 16. 22. 26	2
45H	Spring for gear index pawl .....	35 12. 16. 22. 26	9

## GEAR OPERATING GROUP (External).

Part No.	Description.	Models.	Price Each.
			£ s. d.
20767	Hand gear change lever .....	35 12. 16. 22. 26	9 6
11036	Gear change lever knob .....	35 12. 16. 22. 26	10
2885	Gear change lever knob spring washer .....	35 12. 16. 22. 26	4 3
11034	Fulcrum screw for hand change lever .....	35 12. 16. 22. 26	4 3
10266	Nut for fulcrum screw .....	35 12. 16. 22. 26	1
4102	Lock washer for fulcrum screw .....	35 12. 16. 22. 26	4 6
20734	Gate for hand gear change .....	35 12. 16. 22. 26	1
3085	Bolt securing gate to tank (2 off) .....	35 12. 16. 22. 26	2
3071	Nut for above .....	35 12. 16. 22. 26	3
20664	Rubber for gate .....	35 12. 16. 22. 26	3
CO26	Hand gear change rod only (state length when ordering) .....	35 12. 16. 22. 26	3 0
2738	Top gear rod yoke end .....	35 12. 16. 22. 26	1 0
2512	Pin for top gear rod yoke end .....	35 12. 16. 22. 26	1 2
STD48	Split pin for top gear rod yoke end pin .....	35 12. 16. 22. 26	1 6
CO46/II.	Bottom gear rod ball joint .....	35 12. 16. 22. 26	1 6
182X	Lock nut for above .....	35 12. 16. 22. 26	3
CO50	Foot gear change pedal .....	35 12. 16. 22. 26	5 0
(O65)	Anchor bolt for foot change pedal .....	35 12. 16. 22. 26	1 3
CO64	Distance collar for anchor bolt .....	35 12. 16. 22. 26	1
102X	Nut for foot change pedal anchor bolt .....	35 12. 16. 22. 26	2
CO49/II.	Foot gear change control body (aluminium) .....	35 12. 16. 22. 26	6 0
CO55/II.	Back plate for control body .....	35 12. 16. 22. 26	1 0
CO56/III.	Outer cap for foot gear control .....	35 12. 16. 22. 26	3 6
CO53/II.	Main plate for foot control (to which pedal axes) .....	35 12. 16. 22. 26	3 6
CO51/II.	Foot gear change index plate .....	35 12. 16. 22. 26	4 0
CO52	Foot gear change index pawl .....	35 12. 16. 22. 26	1 6
CO66/II.	Foot gear change control spring, long .....	35 12. 16. 22. 26	4 4
CO67	Foot gear change control spring, short .....	35 12. 16. 22. 26	2
CO58	End plate for short spring .....	35 12. 16. 22. 26	2
CO59	Fr. plate for long spring .....	35 12. 16. 22. 26	2
CO68	Shim washer for foot change control .....	35 12. 16. 22. 26	1

## FINAL DRIVE GROUP.

Part No.	Description.	Models.	Price Each.
			£ s. d.
251X	Sprocket for rear chain .....	35 12. 16. 22. 26	1 0
284X	Spring collar for sprocket .....	35 12. 16. 22. 26	2 6
82X	Nut securing sprocket to high-speed sleeve pinion .....	35 12. 16. 22. 26	1 9

Always quote both Engine and Frame Numbers when ordering Spare Parts.

### KICKSTARTER GROUP.

Part No.	Description.	Models.	Price Each.
			£ s. d.
121X	Kickstarter crank washer .....	35 12. 16. 22. 26	3
119X	Kickstarter crank toothed quadrant .....	36 12. 16. 22. 26	10 0 0
122X	Kickstarter crank bush (retaining quadrant) .....	35 12. 13. 22. 26	1 6 0
114X	Kickstarter crank only .....	35 12. 16. 22. 26	9 0 0
125X	Kickstarter axle fits in shell .....	35 12. 16. 22. 26	4 6 2
31658	Grease nipple for kickstarter crank .....	35 12. 16. 22. 26	1 0 0
127X	Split pin retaining kickstarter crank .....	35 12. 16. 22. 26	2 0 0
128X	Washer retaining kickstarter crank .....	35 12. 16. 22. 26	1 0 0
115X 1	Pedal pin for kickstarter crank .....	35 12. 16. 22. 26	3 0 0
296X	Kickstarter ratchet plate fits on main-shaft .....	35 12. 16. 22. 26	4 0 0
79X	Nut for main-shaft, kickstarter end .....	35 12. 16. 22. 26	4 0 0
263X	Kickstarter ratchet pinion, 14 teeth .....	35 12. 16. 22. 26	5 0 0
264X	Bush for kickstarter ratchet pinion .....	35 12. 16. 22. 26	2 0 0
265X	Spring for kickstarter ratchet pinion .....	35 12. 16. 22. 26	2 0 9
137X	Spring for kickstarter crank return .....	35 12. 16. 22. 26	2 0 0
129X	Cover plate for kickstarter return spring .....	35 12. 16. 22. 26	2 0 0
135X	Bolt retaining kickstarter cover plate .....	35 12. 16. 22. 26	4 0 0
65X	Nut to bolt retaining kickstarter cover plate .....	35 12. 16. 22. 26	3 0 0
124X	Rubber buffer for kickstarter return .....	35 12. 16. 22. 26	3 0 0
133X	Supporting block for rubber buffer fits in end plate .....	35 12. 16. 22. 26	8 0 0
136X	Washer for bolt retaining kickstarter cover plate .....	35 12. 16. 22. 26	3 0 0

### CLUTCH GROUP.

Part No.	Description.	Models.	Price Each.
			£ s. d.
7X XX1.	Clutch sprocket (50 teeth x 75" pitch) .....	35 12. 16. 22. 26	1 0 0
28 X1	Clutch thrust rod (2 1/2" x 3/16" diam) .....	35 12. 16. 22. 26	1 0 0
6X	Clutch plate (main, 19in x 5 off) .....	35 12. 16. 22. 26	2 0 0
6X A	Clutch plate (thin, thick 1 off) .....	35 12. 16. 22. 26	2 0 0
3X H.	Clutch plate (5" inner ins. fits 45 off) .....	35 12. 16. 22. 26	5 0 0
1X V1.	Clutch shoe pressure plate .....	35 12. 16. 22. 26	12 0 0
12X V.	Screw for shoe stud for pressure plate .....	35 12. 16. 22. 26	9 0 0
15X V.	Screw for shoe stud for pressure plate .....	35 12. 16. 22. 26	6 0 0
2X	Lock nut for pressure stud .....	35 12. 16. 22. 26	6 0 0
3X	Clutch hub .....	35 12. 16. 22. 26	1 0 0
65X	Nut for clutch hub to mainshaft .....	35 12. 16. 22. 26	3 0 0
71X	Plain washer for clutch hub fixing nut .....	35 12. 16. 22. 26	1 0 0
71X M	Locking washer for clutch hub fixing nut .....	35 12. 16. 22. 26	3 0 0
34X	Hardened roller race for clutch sprocket .....	35 12. 16. 22. 26	2 0 0
35X	Clutch sprocket rollers (24 off per set) .....	35 12. 16. 22. 26	3 6 0
26X	Hardened steel washer for clutch sprocket, thick .....	35 12. 16. 22. 26	9 0 0
36X1.	Hardened clutch sprocket washer, thin .....	35 12. 16. 22. 26	6 0 0
21X	Clutch springs 4 off .....	35 12. 16. 22. 26	6 0 0
32X	Clutch spring thumb, 4 off .....	35 12. 16. 22. 26	4 0 0
24X	Clutch spring bolts 4 off .....	35 12. 16. 22. 26	4 0 0
23X	Clutch spring adjusting nuts .....	35 12. 16. 22. 26	4 0 0
12X	Shock absorber rubber for clutch sprocket 4 off .....	35 12. 16. 22. 26	2 0 0
8X	Metal retainer for clutch shock absorber 4 off .....	35 12. 16. 22. 26	9 0 0
9X	Bolt securing metal retainer (4 off) .....	35 12. 16. 22. 26	2 0 0
10X	Nut for bolt securing metal retainer (4 off) .....	35 12. 16. 22. 26	1 0 0
37	Clutch lever bracket (aluminium) .....	35 12. 16. 22. 26	6 6 0
62X	Long stud securing clutch lever bracket .....	35 12. 16. 22. 26	4 4 0
15X	Short stud securing clutch lever bracket .....	35 12. 16. 22. 26	3 3 0
63X	Nut securing clutch lever bracket (2 off) .....	35 12. 16. 22. 26	2 0 0
65X 1	Clutch actuating lever fits on brackets .....	35 12. 16. 22. 26	2 0 0
66X	Fulcrum screw for clutch actuating lever .....	35 12. 16. 22. 26	6 0 0
63X	Lock nut for clutch lever fulcrum screw .....	35 12. 16. 22. 26	2 0 0

### CLUTCH CABLE.

Part No.	Description.	Models.	Price Each.
			£ s. d.
35 1201A	Clutch cable complete assembled .....	35 12. 16. 22. 26	4 6 0
35 1201B	Clutch cable outer case .....	35 12. 16. 22. 26	2 0 0
35 1201C	Clutch cable inner wire 4ft .....	35 12. 16. 22. 26	6 1 0
35 1201D	Nipple for above, handlebar end .....	35 12. 16. 22. 26	1 1 0
35 1201E	Nipple for above, gear box end .....	35 12. 16. 22. 26	1 1 0
816E	Clutch cable adjuster .....	35 12. 16. 22. 26	6 6 0
816E A	Lock nut for above .....	35 12. 16. 22. 26	2 0 0

Always quote both Engine and Frame Numbers when ordering Spare Parts.

### REAR WHEEL AND BRAKE PARTS.

Part No.	Description.	Models.	Price Each.
			£ s. d.
20733B	Rear wheel complete with spindles and bearings, less brake parts, tyre, tube and sprocket .....	All models	3 17 9
20733A	Rear wheel complete with brake, less tyre and tube .....	All models	9 3 0
20733	Rear wheel, less all hub and brake fittings rim, drilled, 19x2 1/2 x 15 gauge, 40 hole .....	All models	2 14 0
12366	Spokes (40) .....	All models	8 3 0
2073A	Nipples (40) .....	All models	1 0 0
11403X	Hub complete with bearings, less solid centre spindle .....	All models	2 10 0
11405	Hub shell .....	All models	1 6 0
11406	Hub adjusting ring .....	All models	1 1 0
11407	Hub adjusting ring lock nut .....	All models	1 1 0
11408	Felt washers (2) .....	All models	1 1 0
11409	Felt washer cup (1) .....	All models	3 3 0
11410	Plain spacings washers (3) .....	All models	3 3 0
11411	Spacing ring for felt washer (1) .....	All models	3 3 0
11412	Hub spring ring (1) .....	All models	3 3 0
11413	Hollow spindle with taper bearings .....	All models	17 0 0
20807	Centre solid spindle, 81" .....	All models	5 6 0
20354	Centre solid spindle distance piece .....	All models	2 3 0
12322	Centre solid spindle nuts (2) .....	All models	2 3 0
20719	Centre solid spindle plain washers (2) .....	All models	1 1 0
20718 1	Rear brake cover plate .....	All models	12 0 0
AD67	Rear brake cover plate grease nipple .....	All models	0 0 0
20826	Rear brake cover plate anchor pin .....	All models	0 0 0
16499	Nut for above .....	All models	3 3 0
2886	Washer for above .....	All models	3 3 0
12078	Nut locking cover plate to centre spindle .....	All models	0 0 0
13536	Split pins for anchor pin (per 1 doz.) .....	All models	2 0 0
1 157	Rear brake expander .....	All models	2 0 0
3259	Rear brake expander spindle nut .....	All models	2 0 0
2888	Rear brake expander spindle plain washer .....	All models	1 2 0
2770	Rear brake expander lever .....	All models	2 5 0
19148	Rear brake expander lever pin .....	All models	3 0 0
2 733	Rear brake drum and sprocket (50 teeth) .....	All models	1 4 5
2 424	Rear brake drum fixing pins (3) .....	All models	1 4 5
3 485	Rear brake drum fixing pin nuts (3) .....	All models	1 4 5
2 274 1A	Rear brake shoes, top .....	All models	1 0 0
2 274 1B	Rear brake shoes, bottom .....	All models	1 0 0
2 4408	Rear brake shoe springs (2) .....	All models	2 0 0
3836-3	Brake lining with rivets .....	All models	2 0 0
20788	Rear brake operating pedal .....	All models	7 0 0
1168	Rear brake operating pedal grease nipple .....	All models	2 0 0
17194 L	Brake spindle bush .....	All models	4 4 0
20841	Distance piece between engine plates .....	All models	5 0 0
20825	Distance piece behind chaincase .....	All models	6 0 0
17184 G	Distance piece inside chaincase .....	All models	3 3 0
20758	Rear brake operating spindle .....	All models	1 4 0
2881	Rear brake operating spindle spring washer .....	All models	1 1 0
2702	Rear brake operating spindle nut, 7/8" .....	All models	1 1 0
3060	Rear brake operating spindle nut, 1" .....	All models	1 1 0
2888	Washer for above (1) .....	All models	7 0 0
29780	Rear brake rod .....	All models	2 3 0
2738	Rear brake rod yoke end .....	All models	10 0 0
2512	Rear brake rod yoke end pin .....	All models	3 0 0
20748	Rear brake rod yoke end pin roller pin .....	All models	1 1 0
20791	Coil spring for rear brake rod .....	All models	6 6 0
11762	Plain washer for rear brake rod .....	All models	2 2 0
11772	Rear brake rod fixing yoke .....	All models	1 6 0
11749	Rear brake rod adjusting knob .....	All models	1 9 0

### FRONT WHEEL AND BRAKE PARTS.

Part No.	Description.	Models.	Price Each.
			£ s. d.
20764AB	Front wheel complete with brake fittings and bearings, less tyre and tube .....	All models	4 15 0
20764A	Front wheel with bearings, less brake fittings, tyre and tube .....	All models	3 11 6
20764	Front wheel complete, less bearings and brake parts .....	All models	2 4 6
20334	Front hub only .....	All models	1 6 3
1168	Front hub grease nipple .....	All models	3 0 0
11908	Front hub hollow spindle assembled with bearings .....	All models	15 9 0
20677	Rim drilled, 19x2 1/2 x 15 gauge, 40 hole .....	All models	9 3 0
20676	Spokes, long (20) .....	All models	8 3 0
20676	Spokes, short (20) .....	All models	2 0 0

Always quote both Engine and Frame Numbers when ordering Spare Parts.

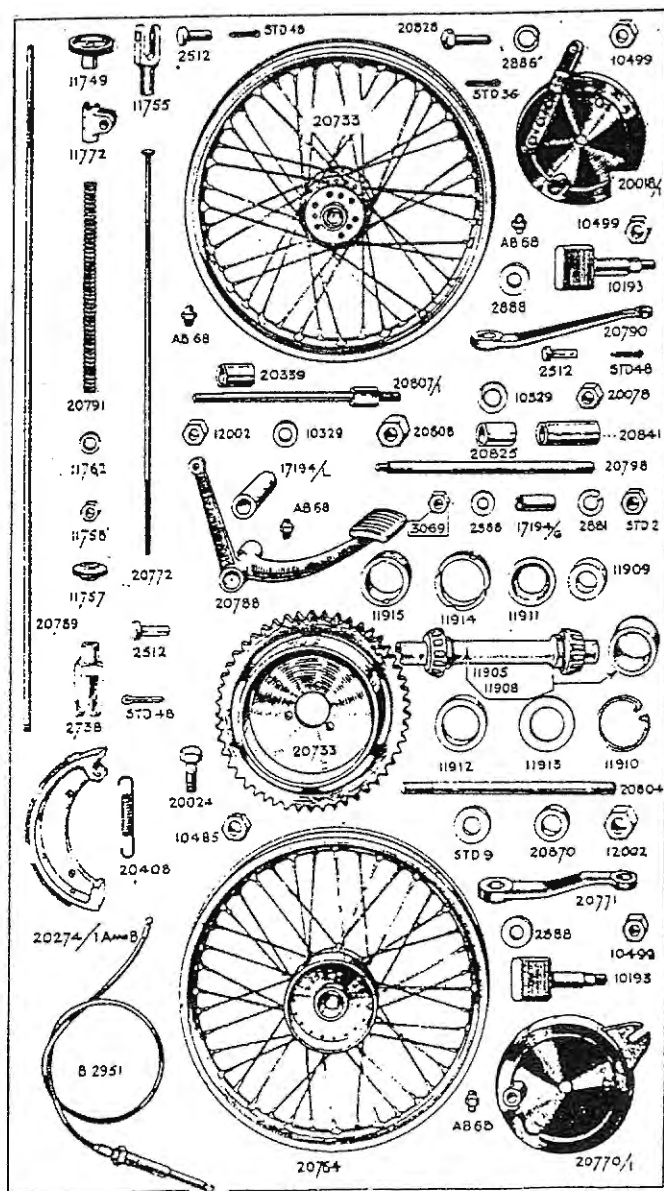

Part No.	Description.	Models.	Price Each.
20678	Spoke nipples (40)	All models	£. s. d. 1 6 1
11915	Hub adjusting ring	All models	1 6 6
11914	Hub adjusting ring lock nut	All models	1 6 3
11909	Felt washers (2)	All models	2 6 2
11913	Plain spacing washer (1)	All models	6 6 6
11912	Spacing collar (3)	All models	2 6 3
11911	Felt washer cup (2)	All models	2 6 2
11910	Hub spring ring (1)	All models	2 6 3
20804	Wheel centre spindle, 61" (1)	All models	2 6 2
20870	Distance piece for centre spindle (2)	All models	3 6 3
STD 9	Washer for centre spindle (2)	All models	1 6 3
12002	Nuts for centre spindle (2)	All models	1 6 3
20770/1	Front brake cover plate	All models	10 6 6
11468	Front brake cover plate grease nipple	All models	6 6 3
20801	Front brake cover plate distance piece	All models	3 6 3
20871	Front brake cover plate packing washer	All models	1 6 3
10193	Front brake expander (1)	All models	5 6 3
2888	Front brake expander spindle washer	All models	1 6 1
10499	Front brake expander spindle nut	All models	2 6 2
20771	Front brake expander spindle lever (1)	All models	2 6 2
20274.1	Front brake shoes (2)	All models	2 6 2
20406	Front brake shoe springs (2)	All models	4 6 0
3636-3	Front brake shoe linings, and rivets	All models	2 6 2
20772	Front brake rod	All models	2 6 2
11755	Front brake rod yoke end	All models	10 6 9
2512	Front brake rod yoke end pin	All models	3 6 3
STD 48	Front brake rod, yoke end pin cotter pin	All models	1 6 1
11758	Front brake rod nut	All models	4 6 4
11757	Front brake rod adjuster	All models	1 6 0
32951	Front brake cable complete with spring box and adjuster	All models	3 6 6
R2950	Front brake inner wire only, 2'31"	All models	1 6 6
R2955	Front brake outer case only, 1'91"	All models	1 6 2
11751	Front brake cable adjuster	All models	2 6 3
11750	Lock nut for above	All models	1 6 3
11756	Outer portion of spring box	All models	1 6 1
11752	Inner portion of spring box	All models	1 6 1
11763	Spring box spring	All models	4 6 4

## BATTERY AND LAMPS (35/4, 12. 16).

Part No.	Description.	Models.	Price Each.
B612	Battery, less lid, Exide	35 4, 12. 16	£. s. d. 17 6 6
180	Lid for battery	35 4, 12. 16	2 6 0
	Battery terminal nuts (2 off)	35 4, 12. 16	1 6 2
	Spring washers for above (2 off)	35 4, 12. 16	1 6 1
DE285	Battery carrier only	35 4, 12. 16	4 6 4
JE180	Battery carrier pinch bolt	35 4, 12. 16	3 6 3
JE177	Screwed collar for above	35 4, 12. 16	3 6 3
JE178	Plain collar for above	35 4, 12. 16	2 6 2
STD 4	Nut securing battery carrier to frame	35 4, 12. 16	1 6 1
STD 11	Washer for above	35 4, 12. 16	6 6 6
DE181/B	Bottom battery carrier fixing strap	35 4, 12. 16	1 6 1
STD 40	Screw securing above to battery carrier	35 4, 12. 16	1 6 1
80E	Head lamp complete with fittings and bulbs	35 4, 12. 16	1 17 6
109	Head lamp shell	35 4, 12. 16	10 6 6
101	Head lamp rim with catch	35 4, 12. 16	6 6 9
102	Head lamp glass	35 4, 12. 16	1 6 3
103	Front lamp glass rubber	35 4, 12. 16	3 6 3
105	Front glass retaining spring	35 4, 12. 16	10 6 0
106	Reflector	35 4, 12. 16	1 6 1
107	Main bulb holder	35 4, 12. 16	1 6 1
108	Main bulb holder spring	35 4, 12. 16	1 6 1
	Head lamp large bulb, double filament, 6 volt 18 x 18 watts	35 4, 12. 16	3 6 3
	Head lamp bulb, small, 6 volt 3 watts	35 4, 12. 16	1 6 3
FFF73	Head lamp bracket, long	35 4, 12. 16	6 6 6
10FF74	Head lamp bracket, short	35 4, 12. 16	6 6 6
HM7	Bolt securing brackets to fork girder (2)	35 4, 12. 16	3 6 3
STD 12	Washer for above	35 4, 12. 16	1 6 4
110	Bolt securing bracket to head lamp (2)	35 4, 12. 16	7 6 6
	Rear lamp complete	35 4, 12. 16	1 6 0
121	Main portion of rear lamp with red glass	35 4, 12. 16	2 6 0
122	Back portion of rear lamp, less bulb	35 4, 12. 16	2 6 0
FLR3	Rear lamp bulb, 6 volt 3 watts	35 4, 12. 16	1 6 3
121A	Screws for securing rear lamp to number plate (5 off) with nuts and washers	35 4, 12. 16	2 6 2
123	Bulb holder spring	35 4, 12. 16	2 6 3
124	Bulb holder plunger pad	35 4, 12. 16	5 6 5
119	Rear lamp glass	35 4, 12. 16	3 6 3
120	Rear lamp mount	35 4, 12. 16	3 6 3

Always quote both Engine and Frame Numbers when ordering Spare Parts.

Part No.	Description.	Models.	Price Each.
AF921	Spring clip for lighting cable, 2" (3 off)...	35 4, 12, 16	.....
AF922	Spring clip for lighting cable, 1 1/2" (2 off)...	35 4, 12, 16	.....
AF923	Spring clip for lighting cable, 4 1/2" (1 off)...	35 4, 12, 16	.....
AF924	Panel complete with switch, ammeter, wiring harness and warning light .....	35 4, 12, 16	1 15 6
125	Switch complete .....	35 4, 12, 16	7 6 0
126	Switch lever .....	35 4, 12, 16	7 6 0
127	Key for switch .....	35 4, 12, 16	7 6 0
128	Ammeter .....	35 4, 12, 16	7 0 0
129	Warning light bulb, 2.5 volts .....	35 4, 12, 16	8 0 0
2234	Rubber for instrument panel .....	35 4, 12, 16	.....
HF22	Electric horn (clear hooper) .....	35 4, 12, 16	15 2 2
HF22 A	Electric horn clip (Lucas) and packing piece .....	35 4, 12, 16	1 1 1
HF23	Electric horn clip bolt .....	35 4, 12, 16	.....
ST105	Nut for above .....	35 4, 12, 16	.....
ST106	Washer for above .....	35 4, 12, 16	.....

## BATTERY AND LAMPS (35/14, 22, 26).

Part No.	Description.	Models.	Price Each.
PCW-E Dry	Battery with lid .....	35 14, 22, 26	17 6 6
522 1/2 6	Vent plug with washer (per doz) .....	35 14, 22, 26	3 9 0
522 3 1	Lid for battery .....	35 14, 22, 26	1 6 0
D142	Head lamp (Lucas) .....	35 14, 22, 26	2 13 1
110	Reflector .....	35 14, 22, 26	.....
111	Back shell .....	35 14, 22, 26	.....
112	Front rim .....	35 14, 22, 26	.....
113	Glass .....	35 14, 22, 26	.....
114	Bulb, main 522 DBMC) .....	35 14, 22, 26	.....
115	Bulb, pilot .....	35 14, 22, 26	.....
116	Tail lamp MT11 (Lucas) .....	35 14, 22, 26	.....
117	Base assembly .....	35 14, 22, 26	.....
118	Body assembly .....	35 14, 22, 26	.....
119	Body .....	35 14, 22, 26	.....
2234 A 22	Instrument panel complete with switch, ammeter, inspection light .....	35 14, 22, 26	2 5 0
2234 B 22	Switch complete .....	35 14, 22, 26	10 0 0
2234 C 22	Ammeter .....	35 14, 22, 26	8 0 0
2234 D 22	Panel .....	All models	10 0 0
2234 E 22	Lighting cable harness .....	All models	9 0 0
2234 F 22	Inspection lamp with switch and bulb .....	All models	6 6 0
2234 G 22	Rest of parts as 35 12 for Brackets, etc.		.....

## SPEEDOMETER GROUP.

Part No.	Description.	Models.	Price Each.
	Speedometer complete, trip type .....	All models	22 5 0
	Speedometer complete, non-trip type .....	All models	22 0 0
	Speedometer head only, trip type .....	All models	1 10 0
	Speedometer head only, non-trip type .....	All models	1 5 0
	Securing nuts for speedometer head (2) .....	All models	1 0 0
	Spring washers for above (2 off) .....	All models	1 2 1
75 128CA	Speedometer drive cable complete, 44" .....	35 12, 16, 22, 26	13 5 0
75 128CB	Speedometer outer casing only .....	35 12, 16, 22, 26	6 6 0
75 128CW	Speedometer inner cable only .....	35 12, 16, 22, 26	6 6 0
75 48CA	Speedometer cable complete, 53" .....	35 4 and 14	16 0 0
75 48CB	Speedometer cable inner wire, 53" .....	35 4 and 14	8 0 0
75 48CW	Speedometer cable outer casing, 53" .....	35 4 and 14	8 0 0
DFE514	Bolt retaining speedometer driving cable, gear box end .....	35 12, 16, 22, 26	3 0 0
ST124	Nut for above .....	35 12, 16, 22, 26	2 0 0
J26 3	Clamp securing outer drive casing to speedometer head .....	All models	4 0 0
J26 6S	Screw for above .....	All models	2 0 0
J26 6S N	Nut for above .....	All models	1 0 0
	Gland rubber for speedometer outer case, gear box end .....	All models	3 0 0
CA-H II	Speedometer drive worm .....	35 12, 16, 22, 26	5 0 0
56M III	Speedometer drive worm .....	35 4 and 14	5 0 0
142N	Bush for speedometer drive worm .....	35 12, 16, 22, 26	7 0 0
2/81	Screw fixing inner cable to head .....	All models	2 0 0
166X	Pin securing speedometer cable in end plate of gear box .....	35 4 and 14	3 0 0

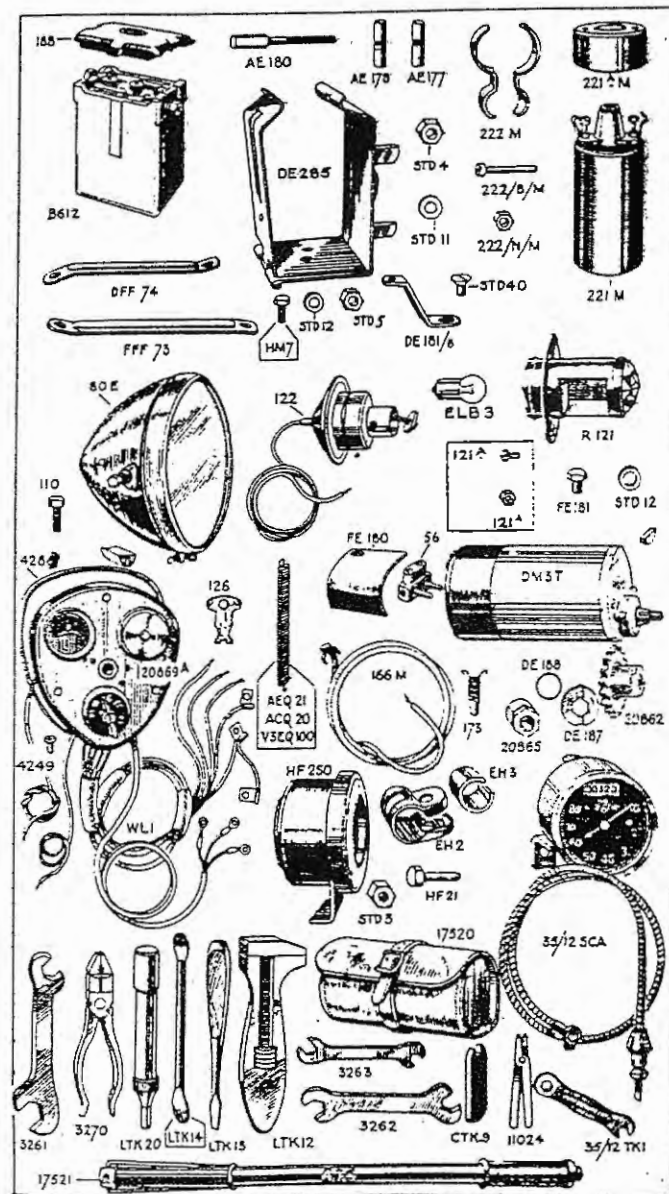

Always quote both Engine and Frame Numbers when ordering Spare Parts.

# CARBURETTOR GROUP.

Part No.	Description.	Models.	Price Each.		
			E	d.	d.
75 154	Carburettor less cables and controls .....	35 12. 16. 22. 26 .....	1	13	6
0 125	Carburettor less cables and controls .....	35 4 and 14 .....	2	0	0
75 154	Mixing chamber .....	35 12 and 22 .....		10	0
75 154	Mixing chamber, engine end, 1" .....	35 16 and 25 .....		10	0
6 165	Mixing chamber .....	35 4 and 14 .....		10	0
5 058	Jet block complete .....	35 12. 16. 22. 26 .....		5	0
6 057	Jet block complete .....	35 4 and 14 .....		5	0
4 042	Mixing chamber union nut .....	35 12. 16. 22. 26 .....		1	6
6 052	Mixing chamber union nut .....	35 4 and 14 .....		1	6
4 051	Mixing chamber cap .....	35 12. 16. 22. 26 .....		1	0
4 052	Mixing chamber cap .....	35 4 and 14 .....		1	0
5 072	Mixing chamber top .....	35 12. 16. 22. 26 .....		1	0
4 053	Mixing chamber top .....	35 4 and 14 .....		1	0
4 054	Cable adjuster .....	All models .....		1	4
4 057	Throttle valve spring .....	All models .....			3
1 059	Air tunnel 1 1/2" I. .....	35 12. 16. 22. 26 .....		2	6
1 060	Air tunnel 1 1/2" I. .....	35 4 and 14 .....		2	6
1 060	Washer for jet block .....	35 12. 16. 22. 26 .....		2	2
6 040	Washer for jet block .....	35 4 and 14 .....		2	2
4 041	Spring cap for needle .....	All models .....		4	4
1 043	Holding bolt .....	All models .....		2	0
5 043	Air valve .....	35 12. 16. 22. 26 .....		2	6
5 043	Air valve .....	35 4 and 14 .....		2	6
4 046	Air valve spring .....	All models .....		3	3
4 047	Air valve spring guide .....	35 12. 16. 22. 26 .....		2	2
6 047	Air valve spring guide .....	35 4 and 14 .....		2	2
5 052	No. 3 throttle valve .....	35 12 and 22 .....		10	10
5 052	No. 4 throttle valve .....	35 16 and 25 .....		10	10
5 052	No. 4 throttle valve .....	35 4 and 14 .....		5	10
4 053	Holding bolt washer .....	All models .....		1	2
4 051	Needle jet .....	All models .....		1	0
5 053	Needle jet 1 1/2" .....	35 12. 16. 22. 26 .....		1	3
5 053	Needle jet 1 1/2" .....	35 4 and 14 .....		1	3
15 1200	Air adjuster screw .....	All models .....		6	6
15 1207	Nut for screw .....	All models .....		2	2
1 042	Main jet No. 124 .....	35 12. 16. 22. 26 .....		5	5
1 043	Main jet No. 125 .....	35 4 and 14 .....		5	5
4 047	Throttle jet screw .....	All models .....		6	6
15 1587	Nut for hose .....	All models .....		2	2
1 061	Split nut for throttle valve .....	All models .....		2	2
12 077	Float chamber, modern .....	35 12 and 22 .....		14	6
12 067	Float chamber complete .....	35 16 and 25 .....		14	6
14 098	Float chamber complete, bent at 20° to standard .....	35 4 and 14 .....	1	0	6
14 042	Float chamber only, bent at 20° to standard .....	35 4 and 14 .....		12	0
22 042	Float chamber only .....	35 12 and 22 .....		8	6
22 042H7	Float chamber only .....	35 16 and 25 .....		8	6
22 042	Float chamber cover .....	35 12 and 22 .....		8	6
1 041	Float chamber cover .....	35 16 and 25 .....		8	6
22 042	Float chamber cover .....	35 4 and 14 .....		2	6
1 041	Float chamber cover .....	35 12. 16. 22. 26 .....		2	6
1 041	Float chamber cover .....	35 4 and 14 .....		2	6
22 042	Needle valve .....	35 12 and 22 .....			11
22 043	Needle valve .....	35 16 and 25 .....			11
14 070	Needle valve .....	35 4 and 14 .....			11
12 021	Tickler .....	35 12. 16. 22. 26 .....			7
12 051	Tickler .....	35 4 and 14 .....			7
12 052	Tickler spring .....	All models .....			2
12 053	Tickler cover .....	All models .....			1
14 025	Petrol union nut .....	All models .....			5
14 025	Petrol union nipple .....	All models .....			3
ACCA	Air control cable complete, 3'11" .....	All models .....		3	
ACTC	Air control outer cable, 3'5" .....	All models .....		2	
ACTW	Air control inner wire, 3'11" .....	All models .....			0
TCCA	Throttle control cable complete, 4'3" .....	All models .....		3	0
TCOC	Throttle control outer cable, 3'9" .....	All models .....		2	0
TCIW	Throttle control cable inner wire 4'3" .....	All models .....			0

Always quote both Engine and Frame Numbers when ordering Spare Parts.