

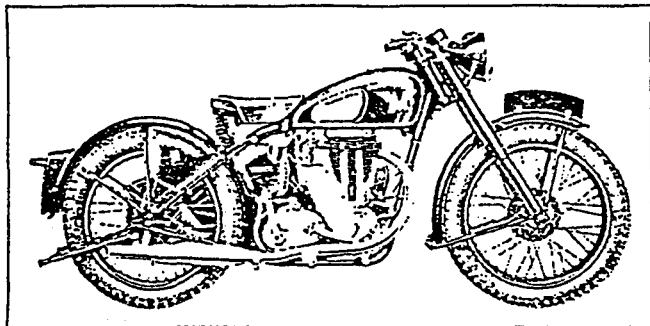



# SPARES LIST



Compiled and Issued by the Manufacturers:

## MATCHLESS MOTOR CYCLES

(Proprietors: ASSOCIATED MOTOR CYCLES LIMITED)

### 1946 MATCHLESS "Clubman" MODELS

350 "CLUBMAN" Model G3L      500 "CLUBMAN" Model G80

46 G3L — Bore 69 mm.      Stroke 93 mm.      Capacity 347 c.c.

46 G80 — Bore 82.5 mm.      Stroke 93 mm.      Capacity 498 c.c.

#### NOTE.

The numbers, in brackets, that appear in the "Description" columns relate to the numbered foot notes regarding items so specially indicated.

The quantities per machine of each item are entered in the "Qty" columns.

Parts for the 500 c.c. model that are not common to both 350 c.c. and 500 c.c. machines are not illustrated.

The illustrations are not to scale and are not necessarily accurate in detail.

EACH SERIES OF FRAMES IS NUMBERED FROM ZERO UPWARDS. THEREFORE THE QUOTATION OF A FRAME NUMBER ONLY DOES NOT PERMIT A MACHINE TO BE IDENTIFIED.

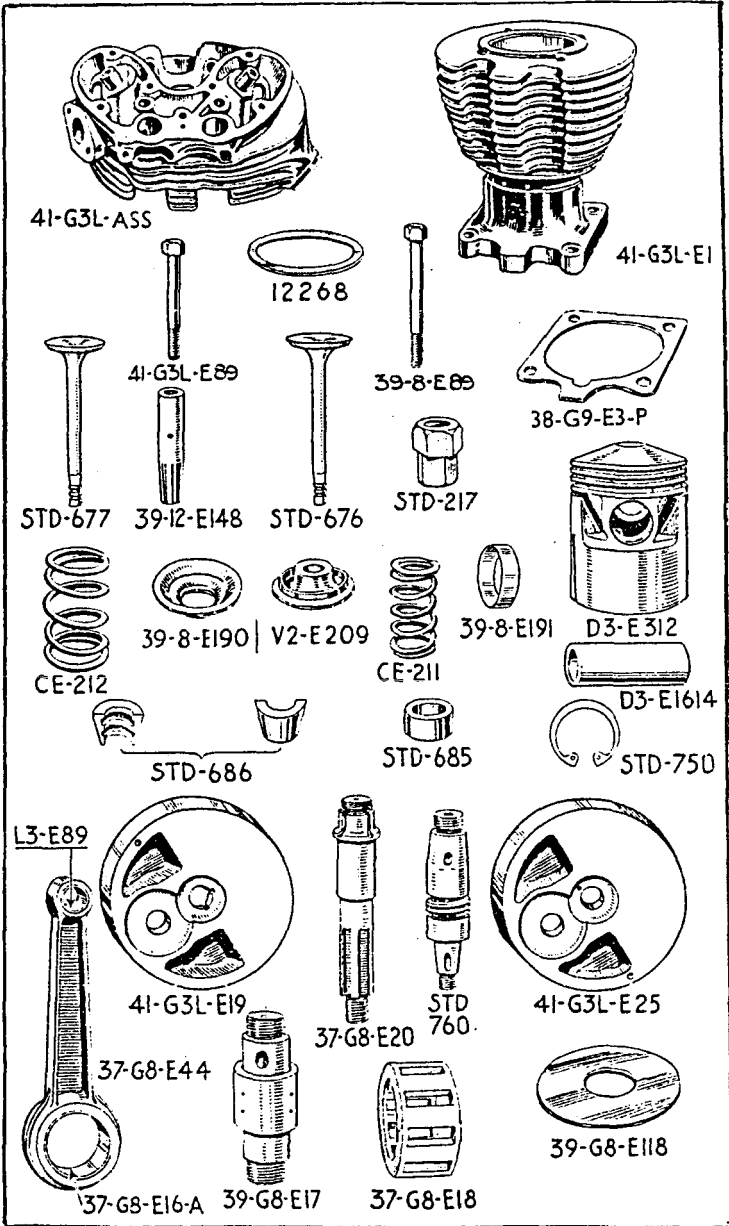

## ENGI    SECTION.

PART NUMBER.	DESCRIPTION.	QTY.	USED ON.	PRICE EACH £ s. d.
<b>CYLINDER.</b>				
41-G3L-E1	Barrel, cylinder	1	350	3 0 0
010947	Barrel, cylinder	1	500	3 15 0
38-G9-E3-P	Plate, compression, cylinder barrel base	1	500	2 7
37-8-E3	Washer, paper, cylinder base	1	350	3
39-8-E3	Washer, paper, cylinder base	1	500	3
39-8-E3	Washer, paper, compression plate	1	500	3
STD-217	Nut, retaining cylinder to crankcase	4	All	7
<b>CYLINDER HEAD.</b>				
41-G3L-E2-ASS	Head, cylinder, with valve guides	1	350	4 17 6
39-18-E2-ASS	Head, cylinder, with valve guides	1	500	5 5 0
41-G3L-E2	Head, cylinder, less valve guides	1	350	4 10 0
39-18-E2	Head, cylinder, less valve guides	1	500	4 17 6
12268	Gasket, cylinder head	1	350	7
38-G9-E4	Gasket, cylinder head	1	500	1 3
41-G3L-E89	Bolt, securing head to barrel, left, short	2	350	1 3
39-8-E89	Bolt, securing head to barrel, right, long	2	350	1 3
39-8-E89	Bolt, securing head to barrel	4	500	1 3
STD-10	Washer, plain, head securing bolt	4	All	1
STD-291	Stud, fixing carburetter	2	All	4
STD-4	Nut, carburetter stud	2	All	3
<b>ENGINE VALVES.</b>				
STD-676	Valve, inlet	1	350	9 9
STD-678	Valve, inlet	1	500	12 9
STD-677	Valve, exhaust	1	350	11 3
STD-679	Valve, exhaust	1	500	12 9
C-E211	Spring, inner, for valve	2	All	9
C-E212	Spring, outer, for valve	2	All	1 6
V2-E209	Collar, valve spring	2	All	1 9
39-8-E190	Cup, valve spring	2	All	6
39-8-E191	Sleeve, spacing, exhaust valve spring cup	1	All	4
STD-686	Collet, for valve. (Each in two pieces)	2	All	1 1
STD-685	Cap, for valve stem	2	All	10
39-12E148	Guide, for valve. (Inlet or exhaust)	2	All	3 9
<b>PISTON.</b>				
D3-E312-A	Piston, complete (1)	1	350	1 7 3
38-G9-E12-A	Piston, complete (1)	1	500	1 14 7
D3-E312	Piston, bare	1	350	16 6
38-G9-E12	Piston, bare	1	500	1 2 6
D3-E311	Ring, compression, 2 ft in. by ¼ in.	2	350	1 6
D5-E611	Ring, compression, 3 ½ in. by ¼ in.	2	500	1 9
38-G3-E111	Ring, scraper, 2 ft in. by ¼ in.	1	350	2 3
36-G8-E111	Ring, scraper, 3 ½ in. by ¼ in.	1	500	2 9
D3-E1614	Pin, gudgeon	1	350	4 6
D5-E614	Pin, gudgeon	1	500	4 10
STD-750	Circlip, for gudgeon pin	2	All	6
The following oversize parts can be supplied.				
o/D3-E312-A	Piston, complete, -020 in. oversize. (Note 1)	1	350	1 7 3
o/38-G9-E12-A	Piston, complete, -020 in. oversize. (Note 1)	1	500	1 14 7
o/D3-E312	Piston, bare, -020 in. oversize	1	350	16 6
o/38-G9-E12	Piston, bare, -020 in. oversize	1	500	1 2 6
o/D3-E311	Ring, compression, 2 ft + -020 in. by ¼ in.	2	350	1 6
o/D5-E611	Ring, compression, 3 ½ + -020 in. by ¼ in.	2	500	1 9
o/38-G3-E111	Ring, scraper, 2 ft + -020 in. by ¼ in.	1	350	2 3
o/36-G8-E111	Ring, scraper, 3 ½ + -020 in. by ¼ in.	1	500	2 9

NOTE 1.—"Piston, complete" includes—Piston, two compression rings, one scraper ring, gudgeon pin and two circlips.

PART NUMBER.	DESCRIPTION.	QTY.	USED ON.	PRICE EACH £ s. d.
--------------	--------------	------	----------	-----------------------

### RE-BORING.

Cylinders may be re-bored to .020 in. oversize and pistons (with rings) supplied to suit.

350 Model ... £1 16s. 3d. ... (New gudgeon pin and circlips 5s. 6d. extra.)

500 Model ... £2 3s. 3d. ... (New gudgeon pin and circlips 5s 10d. extra.)

Cylinders sent for re-boring should be packed in stout cases which will be used by us for their return. Carriage is additional. If a complete machine, or engine, is sent to us for cylinder re-boring, there will be an additional charge, according to the time taken for dismantling and assembly.

### FLYWHEELS.

41-G3L-E19	Flywheel, bare, driving side.....	1	350	1 1 0
39-G9-E19	Flywheel, bare, driving side.....	1	500	1 2 6
41-G3L-E25	Flywheel, bare, timing side.....	1	350	18 9
39-G9-E25	Flywheel, bare, timing side.....	1	500	1 2 6
STD-760	Axle, timing side flywheel.....	1	All	12 0
37-G8-E20	Axle, driving side flywheel.....	1	All	1 0 3
STD-573	Key, driving side flywheel axle.....	2	All	4
STD-230	Nut, timing side flywheel axle.....	1	All	7
STD-234	Nut, driving side flywheel axle.....	1	All	7
STD-15	Screw, lock, timing side flywheel axle nut.....	1	All	1

### CONNECTING ROD.

37-G8-E44	Rod, connecting, with liner and bush.....	1	All	15 3
37-G8-E16-A	Liner, for big-end bearing.....	1	All	6 9
L3-E89	Bush, for gudgeon pin.....	1	All	4 0
STD-75	Roller, crankpin, $\frac{1}{2}$ in. by $\frac{1}{2}$ in.....	30	All	3
37-G8-E18	Cage, for crankpin rollers.....	1	All	11 3
39-G8-E17	Crankpin.....	1	All	15 9
39-G8-E118	Washer, for crankpin.....	2	All	1 6
STD-233	Nut, for crankpin.....	2	All	7

The following oversize part can be supplied but we recommend only skilled mechanics should fit same because it is almost general that the big-end journals and sieves require "lapping" to ensure a correct fit.

O STD-75	Roller, crankpin, $\frac{1}{2}$ + .001 in. dia. by $\frac{1}{2}$ in. long ...	30	All	3
----------	---	----	-----	---

### CRANKCASE.

41-G3-E108	Crankcase, complete (2).....	1	350	6 18 7
010938...	Crankcase, complete (2).....	1	500	7 6 3
37-8-E30	Crankcase, driving side only (3).....	1	350	3 5 7
39-8-E30	Crankcase, driving side only (3).....	1	500	3 11 3
41-G3-E31	Crankcase, timing side only (3).....	1	350	3 13 0
010933...	Crankcase, timing side only (3).....	1	500	3 15 0
STD-575	Plug, drain, for crankcase.....	1	All	6
STD-485	Screw, plug, for crankcase oil holes.....	3	All	1
STD-203	Washer, fibre, for oil hole screws.....	3	All	1
STD-576	Body, for cylinder oil feed valve.....	1	350	4
39-8-E510	Body, for cylinder oil feed valve.....	1	500	6
STD-21	Ball, for cylinder oil feed valve.....	1	All	1
STD-701	Spring, for cylinder oil feed valve.....	1	All	3
STD-300	Stud, for cylinder base.....	4	All	4
35-G3-E32	Cover, timing gear, with bushes.....	1	All	18 9
37-8-E78	Washer, paper, timing gear cover.....	1	All	3
STD-577	Peg, dowel, locating timing gear cover.....	2	All	1
STD-765	Cap, in timing gear cover, for cam bush.....	1	All	4
STD-482	Screw, fixing timing gear cover.....	5	All	3
41-G3L-E29	Cover, magneto chaincase.....	1	All	7 6
STD-484	Screw, fixing magneto chaincase cover.....	6	All	3
STD-51	Nipple, grease, magneto chaincase cover.....	1	All	3

NOTE 2.—"CRANKCASE, COMPLETE" includes all bushes and the cylinder base studs, but does not include timing gear and magneto chain covers.

NOTE 3.—Halves of chaincases must be matched in the Factory. Therefore it is necessary to send the sound half of a crankcase when ordering a new half.

PART NUMBER.	DESCRIPTION.	QTY.	USED ON.	PRICE EACH £ s. d.
--------------	--------------	------	----------	-----------------------

### CRANKCASE BEARINGS.

41-G3-E27	Bush, timing side flywheel axle.....	1	All	3 9
R-137	Rollers and cage, for timing side axle.....	1	All	7 10
41-G3-E541	Sleeve, for timing side roller bearing.....	1	All	4 6
RLS-8	Ball bearing, for driving side axle.....	2	All	16 0
16866	Washer, spacing, between ball bearings.....	1	All	4
16889-A	Collar, spacing, between ball bearings.....	1	All	1 0
STD-651	Bush, for exhaust cam, in crankcase.....	1	All	2 7
STD-651	Bush, for exhaust cam, in timing cover.....	1	All	2 7
STD-651	Bush, for inlet cam, in crankcase.....	1	All	2 7
STD-652	Bush, for inlet cam, in timing cover.....	1	All	2 7

Dimensions of RLS-8 bearing ... 1 in. by 2½ in. by ½ in.

Dimensions of R-137 Rollers and cage ... ½ in. by 1½ in. by ⅜ in.

### CRANKCASE BOLTS.

STD-278	Bolt, front, top position, 4 ⅞ in. by ⅝ in.....	1	All	6
STD-278	Bolt, front, centre position, 4 ⅞ in. by ⅝ in.....	1	All	6
STD-273	Bolt, front, bottom position, 3 ⅞ in. by ⅝ in.....	1	350	4
STD-277	Bolt, front, bottom position, 4 ½ in. by ⅝ in.....	1	500	6
STD-261	Bolt, bottom, rear position, 4 ½ in. by ½ in.....	1	All	6

For the "Bolt, bottom, front position" (which also unites the front and rear frames) see "FRAME," page 24.

STD-274	Bolt, rear, top position, 3 ½ in. by ⅝ in.....	1	350	4
STD-278	Bolt, rear, top position, 4 ⅞ in. by ⅝ in.....	1	500	6
STD-274	Bolt, rear, centre position, 3 ½ in. by ⅝ in.....	1	350	4

For the "Bolt, rear, centre position" on 500 c.c. machines, see "STD-316, bolt, fixing centre of chaincase, on page 28, "FRONT CHAINCASE."

STD-274	Bolt, rear, bottom position, 3 ½ in. by ⅝ in.....	1	350	4
STD-277	Bolt, rear, bottom position, 4 ½ in. by ⅝ in.....	1	500	6
40-G3-F66	Spacer, for front, top bolt.....	2	350	6
40-G3-F66	Spacer, for front, centre bolt.....	2	350	6
STD-11	Washer, plain, for front, top bolt.....	2	All	1
STD-11	Washer, plain, for front, centre bolt.....	2	All	1
STD-5	Nut, for bottom, rear bolt (½ in.).....	2	All	3
STD-4	Nut, for all front and rear bolts (⅝ in.).....	12	350	3
STD-4	Nut, for all front bolts and top and bottom position rear bolts (⅝ in.).....	10	500	3

### OIL PUMP.

STD-770	Plunger, oil pump.....	1	All	9 0
38-12-E96	Screw, guide, oil pump plunger.....	1	All	9
STD-773	Cap, front end, oil pump.....	1	All	1 6
STD-772	Cap, rear end, oil pump.....	1	All	9
STD-582	Washer, paper, pump end cap.....	2	All	1
STD-15	Screw, fixing front end cap, oil pump.....	4	All	1
STD-591	Bolt, fixing rear end cap, oil pump.....	4	All	3

### RELEASE VALVE.

STD-836	Body, release valve.....	1	All	1 6
STD-835	Diaphragm, for release valve.....	1	All	3

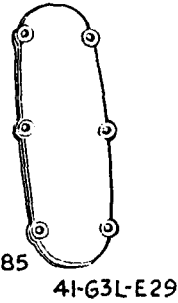
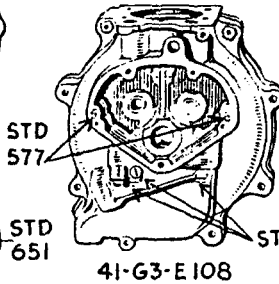
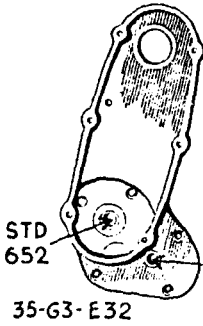
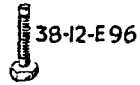
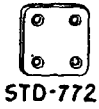

STD  
652

STD  
577  
STD  
651

STD-485

35-G3-E32

41-G3-E108

41-G3L-E29



RL5-8

16889-A

STD  
575

41-G3-E27

168 66

R-137

41-G3-E541

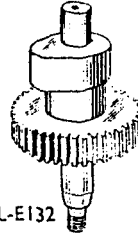
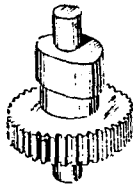

R4-E1028

D8-E2931

STD  
835

STD-836

42-G3L-E132

STD  
670-A



STD  
661

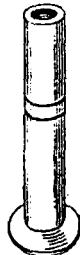

STD-671-A



STD  
638



STD-662



PART NUMBER.	DESCRIPTION.	QTY.	USED ON.	PRICE EACH £ s. d.
--------------	--------------	------	----------	-----------------------

### TIMING GEAR.

42-G3L-E132	Camshaft, inlet.....	1	All	20 0
D8-E2931	Camshaft, exhaust.....	1	All	17 6
R4-E1028	Pinion, timing, on flywheel axle.....	1	All	5 7
STD-570	Key, for timing pinion.....	1	All	4
STD-221	Nut, retaining timing pinion to axle.....	1	All	4

### TAPPETS.

STD-670-A	Tappet, inlet, bare.....	1	350	3 9
39-G9-E84-I	Tappet, inlet, bare.....	1	350	3 9
STD-671-A	Tappet, exhaust, bare.....	1	500	4 10
39-G9-E84-E	Tappet, exhaust, bare.....	1	500	4 10
STD-638	Collar, for exhaust, tappet.....	1	All	1 6
STD-661	Guide, for inlet tappet.....	1	350	3 9
39-G9-E83-I	Guide, for inlet tappet.....	1	500	3 9
STD-662	Guide, for exhaust tappet.....	1	350	6 0
39-G9-E83-E	Guide, for exhaust tappet.....	1	500	6 0

### PUSH RODS.

20818-1	Rod, long, push, complete (4).....	2	350	6 4
39-G9-E114	Rod, long, push, complete (4).....	2	500	6 4
20818	Rod, long, push, bare.....	2	350	1 9
39-G9-E113	Rod, long, push, bare.....	2	500	1 9
STD-721	End, ball, bottom of long push rod.....	2	All	1 6
STD-720	End, sleeve, top of long push rod.....	2	All	1 1
STD-592	Screw, adjusting, top of long push rod.....	2	All	1 6
STD-216	Nut, lock, push rod adjusting screw.....	2	All	6

NOTE 4.—"ROD, LONG, PUSH, COMPLETE" comprises—one long push rod, one bottom ball end, one top end sleeve, one adjusting screw and one lock nut.

### PUSH RODS COVER TUBES.

39-16-E163	Tube, cover, for long push rod.....	2	350	3 9
39-G9-E163	Tube, cover, for long push rod.....	2	500	3 9
38-G4-E368	Gasket, for top of cover tube.....	2	All	6
38-G4-E379	Washer, plain metal, top of gasket (5).....	2	350	4
39-8-E379	Washer, plain metal, top of gasket.....	2	500	4
STD-691	Gland, rubber, bottom of cover tube.....	2	All	4

NOTE 5.—This is used on 500, in lieu of 39-8-E379, when the compression plate 38-G9-E3-P is discarded.

### ROCKER BOX.

39-8-E61-ASS	Box, rocker, assembled (6).....	1	All	4 8 0
39-8-E61-B	Box, rocker, with bushes (7).....	1	All	1 19 6
39-8-E61	Box, rocker, bare.....	1	All	1 10 0
39-8-E452	Bolt, fixing rocker box, short head.....	1	All	1 0
39-8-E451	Bolt, fixing rocker box, long head.....	6	350	10
39-8-E451	Bolt, fixing rocker box, long head.....	5	500	10
010930...	Bolt, fixing rocker box, with extension.....	1	500	1 0
STD-11	Washer, plain, rocker box fixing bolt.....	7	All	1
41-G3-E85-A	Cover, side, for rocker box.....	1	All	5 3
38-G4-E65	Fillet, rubber, rocker box side cover.....	1	All	3
STD-251	Stud, fixing rocker box side cover.....	3	All	3
STD-623	Nut, for rocker box side cover stud.....	3	All	7
STD-205	Washer, fibre, for rocker box side cover nut.....	3	All	1
39-8-E440	Gasket, for rocker box.....	1	All	6
38-G4-E204	Bush, for rocker box.....	4	All	2 3

NOTE 6.—Includes all parts listed in this paragraph and all those listed in the following paragraph (Overhead Rockers).

NOTE 7.—This is a "bare" rocker box to which is fitted—four 38-G4-E204 rocker box bushes and two D8-E1865 felt rings.

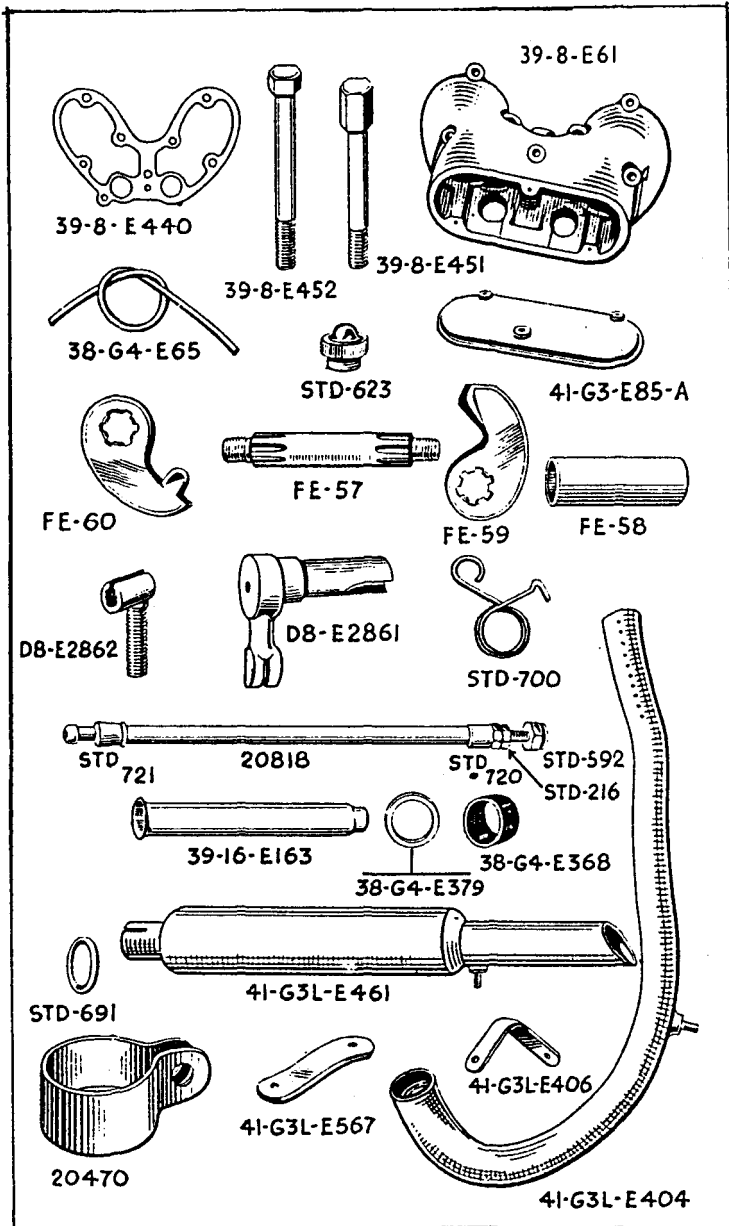

PART NUMBER.	DESCRIPTION.	QTY.	USED ON.	PRICE EACH £ s. d.
--------------	--------------	------	----------	-----------------------

### OVERHEAD ROCKERS.

F-E57 ... ..	Axle, rocker.....	2 ...	All ...	5 3
F-E58 ... ..	Sleeve, for rocker axle.....	2 ...	All ...	4 6
F-E59 ... ..	Arm, rocker, valve end, inlet and exhaust.....	2 ...	All ...	3 9
F-E60 ... ..	Arm, rocker, tappet end, inlet and exhaust.....	2 ...	All ...	3 4
STD-10 ... ..	Washer, plain, for rocker axle.....	4 ...	All ...	1
STD-3 ... ..	Nut, for rocker axle.....	2 ...	All ...	3
DB-E1865 ... ..	Ring, felt, for rocker axle sleeve.....	2 ...	All ...	3

### ROCKER BOX STAY.

010931... ..	Stay, for rocker box.....	1 ...	500 ...	1 0
STD-4 ... ..	Nut, fixing stay to rocker box bolt extension.....	1 ...	500 ...	3
STD-11 ... ..	Washer, plain, rocker box bolt extension.....	1 ...	500 ...	1
010970... ..	Clip, for rocker box stay.....	1 ...	500 ...	9
STD-363 ... ..	Bolt, for rocker box stay clip.....	1 ...	500 ...	4
STD-11 ... ..	Washer, plain, rocker box stay clip bolt.....	1 ...	500 ...	1
STD-4 ... ..	Nut, rocker, box stay clip bolt.....	1 ...	500 ...	3

### EXHAUST VALVE LIFTER.

DB-E2861 ... ..	Lever, with spindle exhaust lifter.....	1 ...	All ...	5 3
STD-700 ... ..	Spring, for valve lifter lever.....	1 ...	All ...	4
DB-E2862 ... ..	Crosshead, for valve lifter cable.....	1 ...	All ...	1 1
STD-11 ... ..	Washer, plain, lifter cable crosshead.....	1 ...	All ...	1
STD-74 ... ..	Nut, lock, lifter cable crosshead.....	1 ...	All ...	3

### GASKETS.

We supply gaskets, either as separate spares, or in complete sets.

Single gaskets are listed in the groups to which they belong.

Gaskets in complete sets are listed below.

45-EQ-1 ... ..	Gasket, set for 350 c.c. models.....	1 ...	350	6 6
45-EQ-2 ... ..	Gasket, set for 500 c.c. models.....	1 ...	500	7 6

Each gasket set contains :—

1 Cylinder base washer. (2 in 500 c.c. set)	2 Washers, fork oil level screws.
1 Cylinder head gasket.	1 Gasket, carburetter.
1 Timing gear cover washer.	1 Gasket, carburetter packing piece.
2 Glands, bottom of cover tubes.	1 Gasket, rocker box.
2 Gaskets, top of cover tubes.	2 Washers, oil pump end caps.
1 Fillet, rocker box side cover.	3 Washers, rocker box side cover studs.
2 Washers, petrol feed taps.	1 Washer, oil tank drain plug.
1 Washer, oil filter compartment cap.	1 Chaincase rubber band.
1 Washer, chaincase inspection cap.	

WHEN IN DOUBT REGARDING THE NAMES AND PART NUMBERS OF THE PARTS YOU REQUIRE, PLEASE SEND THE OLD PARTS TO SERVE AS PATTERNS.

## EXHAUST PIPE AND SILENCER SECTION.

PART NUMBER.	DESCRIPTION.	QTY.	USED ON.	PRICE EACH £ s. d.
<b>EXHAUST PIPE.</b>				
41-G3L-E404	... Pipe, exhaust, bare.....	1	350	10 9
011245	... Pipe, exhaust, bare.....	1	500	10 9
4260	... Baffle, for exhaust pipe.....	1	500	4 0
41-G3L-E406	... Stay, for exhaust pipe.....	1	350	1 6
011091	... Stay, for exhaust pipe.....	1	500	2 3
STD-4	... Nut, fixing, exhaust pipe to stay.....	1	All	3
STD-174	... Washer, plain, exhaust pipe fixing nut.....	1	All	1
STD-192	... Washer, spring, exhaust pipe fixing nut.....	1	All	1
<b>SILENCER.</b>				
41-G3L-E461	... Silencer, bare.....	1	350	9 3
011119	... Silencer, bare.....	1	500	9 3
20470	... Clip, clamping silencer to pipe.....	1	350	1 6
STD-745	... Clip, clamping silencer to pipe.....	1	500	1 6
STD-363	... Bolt, for silencer clip.....	1	All	4
STD-174	... Washer, plain, for silencer clip bolt.....	1	All	1
STD-192	... Washer, spring, for silencer clip bolt.....	1	All	1
STD-4	... Nut, for silencer clip bolt.....	1	All	3
41-G3L-E567	... Stay, for silencer.....	1	350	1 6
39-G3-E567	... Stay, for silencer.....	1	500	1 6
STD-4	... Nut, fixing silencer to stay.....	1	All	3
STD-174	... Washer, plain, for silencer fixing nut.....	1	All	1
STD-192	... Washer, spring, for silencer fixing nut.....	1	All	1
STD-363	... Bolt, fixing silencer stay to fork end.....	1	All	4
STD-174	... Washer, plain, for fork end bolt.....	1	All	1
STD-4	... Nut, for fork end bolt.....	1	All	3

## CARBURETTER SECTION.

PART NUMBER.	DESCRIPTION.	QTY.	USED ON.	PRICE EACH £ s. d.
<b>CARBURETTER.</b>				
011064	... Carburetter, complete (less controls).....	1	350	3 0 0
011068	... Carburetter, complete (less controls).....	1	500	3 10 6
41-G3L-E167	... Spacer, for carburetter, $\frac{3}{4}$ in. thick.....	1	350	2 3
36-G8C-E167	... Spacer, for carburetter, $\frac{3}{4}$ in. thick.....	1	500	2 3
STD-581	... Gasket, for carburetter.....	1	All	3
STD-581	... Gasket, for carburetter spacer.....	1	All	3
<b>FLOAT CHAMBER.</b>				
64-186	... Chamber, float, bare.....	1	350	16 6
64-302	... Chamber, float, bare.....	1	500	16 6
13-153	... Screw, plug, passage in float chamber.....	1	All	3
14-039	... Washer, fibre, passage plug screw.....	1	All	1
4-043	... Bolt, holding float chamber.....	1	350	3 0
29-077	... Bolt, holding float chamber.....	1	500	3 0
4-053	... Washer, fibre, chamber holding bolt.....	2	All	2
14-208-B	... Top, (or cover), for float chamber.....	1	All	3 9
14-021	... Screw, locking float chamber top.....	1	All	4

PART NUMBER.	DESCRIPTION.	QTY.	USED ON.	PRICE EACH £ s. d.
--------------	--------------	------	----------	-----------------------

### FLOAT CHAMBER—continued.

14-015	Float, bare.....	1	All	3 9
14-024	Needle, for float.....	1	All	1 6
14-178	Nut, lock, float needle seat.....	1	All	4
14-175	Washer, fibre, float needle seat.....	1	All	2
14-209	Tickler.....	1	All	10
14-210	Stop, for tickler.....	1	All	9
14-032	Spring, for tickler.....	1	All	2
14-289	Cotter, for tickler.....	1	All	1
14-014-R	Spring, bow, for float.....	1	All	4

### MIXING BODY.

76-014	Body, mixing, bare.....	1	350	14 0
89-403	Body, mixing, bare.....	1	500	16 0
6-062	Nut, union, mixing body base.....	1	350	2 3
29-078	Nut, union, mixing body base.....	1	500	3 0
6-040	Washer, fibre, body union nut.....	1	350	2
29-050	Washer, fibre, body union nut.....	1	500	2
6-032-B	Top, for mixing chamber.....	1	350	2 6
29-042	Top, for mixing chamber.....	1	500	3 3
6-031	Ring, fixing top to mixing body.....	1	350	2 6
29-041	Ring, fixing top to mixing body.....	1	500	3 0
4-235	Clip, locking top fixing ring.....	1	350	9
29-201	Clip, locking top fixing ring.....	1	500	?
4-241	Screw, securing locking clip to body top.....	1	All	2
4-035	Adjuster, for control cable, throttle or air.....	2	All	6
206-038-R	Intake, air.....	1	350	3 0
229-048	Intake, air.....	1	500	3 6

### JETS.

6-058	Choke, or jet barrel.....	1	350	7 6
29-068	Choke, or jet barrel.....	1	500	10 6
4-061	Needle jet.....	1	350	2 6
29-076	Needle jet.....	1	500	2 6
4-042-150	Jet, main, size 150.....	1	350	8
4-042-180	Jet, main, size 180.....	1	500	8
6-065	Needle, taper, for needle jet.....	1	350	2 0
29-075	Needle, taper, for needle jet.....	1	500	2 0
4-230	Clip, for jet taper needle.....	1	All	6
4-060	Pin, split, locating taper needle clip.....	1	All	1
13-129	Screw, for pilot jet air adjustment.....	1	All	9
4-206	Nut, lock, for pilot jet air screw.....	1	All	2
<i>We can also supply the following alternative jets.</i>				
4-042-130	Jet, main, size 130.....	1	All	8
4-042-140	Jet, main, size 140.....	1	All	8
4-042-160	Jet, main, size 160.....	1	All	8
4-042-170	Jet, main, size 170.....	1	All	8

### VALVES (CARBURETTER).

6-052	Valve, throttle, size 6 by 4.....	1	350	6 0
29-062	Valve, throttle, size 29 by 4.....	1	500	6 6
4-037	Spring, for throttle valve.....	1	350	4
29-206	Spring, for throttle valve.....	1	500	4
4-063	Screw, stop, for throttle valve.....	1	All	9
4-206	Nut, lock, for throttle stop screw.....	1	All	2
6-045	Valve, air.....	1	350	3 9
29-055	Valve, air.....	1	500	4 0
6-047	Guide, tubular, for air valve spring.....	1	350	1 0
29-057	Guide, tubular, for air valve spring.....	1	500	1 3
4-046	Spring, for air valve.....	1	All	4

4i-G3L-E167

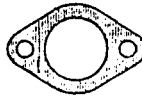
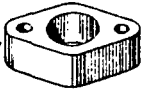

STD-581



4-053



4-043



14-208-B

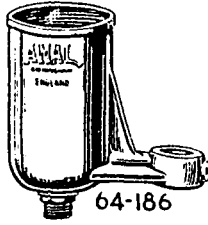

64-186

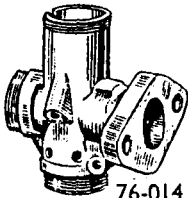

76-014



4-230



14-015



14-021



14-024



6-032-B



6-031



6-062



6-040



4-061

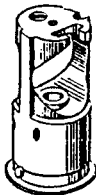

6-058



4-035



4-235

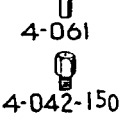

4-042-150



6-065



13-129



4-206

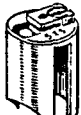

6-052



4-206



4-063



6-045



6-047



4-037



4-046

## TRANSMISSION SECTION.

PART NUMBER.	DESCRIPTION.	QTY.	USED ON.	PRICE EACH £ s. d.
-----------------	--------------	------	-------------	--------------------------

### ENGINE SPROCKET.

20815-18	Sprocket, engine, bare, 18 teeth.....	1	350	14 3
20815-21	Sprocket, engine, bare, 21 teeth.....	1	500	14 3
35-G3-E124	Spacer, collar, for engine sprocket.....	1	All	1 1
STD-830	Cam, engine, shock absorber.....	1	All	7 6
STD-702	Spring, engine shock absorber.....	1	350	1 10
STD-703	Spring, engine shock absorber.....	1	500	2 3
STD-831	Cap, engine shock absorber spring.....	1	All	1 0
STD-610	Nut, lock, engine shock absorber.....	1	All	9

*We can also supply the following alternative engine sprockets.*

20815-15	Sprocket, engine, bare, 15 teeth.....	1	All	14 3
20815-16	Sprocket, engine, bare, 16 teeth.....	1	All	14 3
20815-17	Sprocket, engine, bare, 17 teeth.....	1	All	14 3
20815-19	Sprocket, engine, bare, 19 teeth.....	1	All	14 3
20815-20	Sprocket, engine, bare, 20 teeth.....	1	All	14 3

### CLUTCH SPROCKET.

7-X-28	Chainwheel, bare, 40 teeth (8).....	1	All	1 0 0
34-X-2	Race, roller, clutch sprocket bearing.....	1	All	3 0
35-X	Rollers, clutch sprocket bearing, per set.....	24	All	5 3
36-X-2	Washer, thin, clutch sprocket bearing.....	1	All	1 1
36-X-3	Washer, thick, clutch sprocket bearing.....	1	All	1 1

*NOTE 8.—For chainwheel, assembled with clutch case, see CLUTCH, Page 22.*

### GEAR BOX SMALL SPROCKET.

179-X-7	Sprocket, gear box, 16 teeth.....	1	All	2 6
180-X-8	Collar, spacing, gear box sprocket, $\frac{3}{8}$ in. thick...	1	All	1 6
206-X-2	Washer, spacing, gear box sprocket, $\frac{1}{2}$ in. thick.	1	All	6
176-X	Nut, fixing gear box sprocket to main gear.....	1	All	2 7
206-X-1	Collar, spacing, under gear box sprocket, $\frac{1}{2}$ in. thick.....	1	All	6
210-X	Washer, lock, gear box sprocket nut.....	1	All	9

### REAR WHEEL SPROCKET.

41-G3-B15	Sprocket and brake drum, rear wheel, 42 teeth...	1	All	1 11 6
37-12-H17	Bolt, retaining sprocket to rear hub.....	6	All	4
38-12-H18	Washer, lock, sprocket retaining nut.....	6	All	1
STD-74	Nut, rear wheel sprocket retaining bolt.....	6	All	3

### MAGNETO DRIVING SPROCKETS.

STD-727	Sprocket, magneto, on engine camshaft.....	1	All	6 4
STD-11	Washer, plain, for camshaft sprocket.....	1	All	1
STD-4	Nut, retaining, for camshaft sprocket.....	1	All	3
STD-726	Sprocket, magneto, on armature shaft.....	1	All	6 4
140074...	Washer, plain, armature sprocket.....	1	All	1
171284...	Nut, retaining, armature shaft sprocket.....	1	All	3



20815-18



35-G3-E124



STD-830



STD-702



STD-831



36-X-3



36-X-2



34-X-2

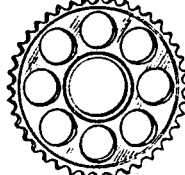

7-X-28



STD-610



206-X-2



206-X-1



176-X



210-X



180-X-8

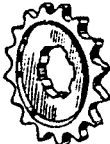

179-X-7



STD-726



STD-725



STD-727

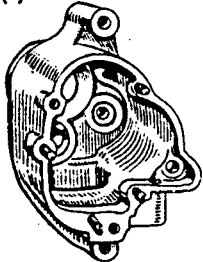

1-CP-16



37-12-H17



38-12-H18

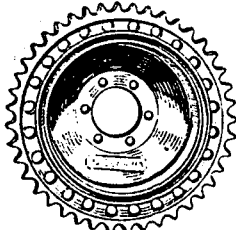

41-G3-B15



STD-164



STD-708



STD-611



326-X

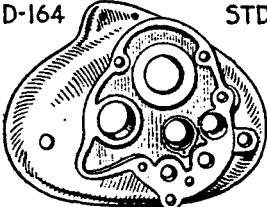

3-C-7

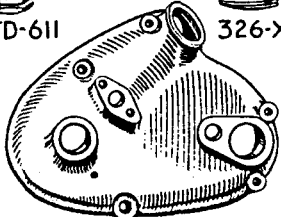

4-C-8



PART NUMBER.	DESCRIPTION.	QTY.	USED ON.	PRICE EACH £ s. d.
--------------	--------------	------	----------	-----------------------

### DYNAMO SPROCKET.

STD-725	Sprocket, on dynamo shaft.....	1	All	5 3
STD-572	Key, for dynamo sprocket.....	1	All	3
STD-10	Washer, plain, dynamo sprocket nut.....	1	All	1
STD-164	Washer, lock, dynamo sprocket nut.....	1	All	3
STD-708	Ring, lock, dynamo sprocket nut.....	1	All	1
STD-611	Nut, retaining dynamo sprocket.....	1	All	9

### CHAINS.

110046-66	Chain, front, 66 Links, $\frac{1}{2}$ in. by .305 in. (9).....	1	350	13 4
110046-67	Chain, front, 67 Links, $\frac{1}{2}$ in. by .305 in. (9).....	1	500	13 6
110056-91	Chain, rear, 91 Links, $\frac{3}{8}$ in. by .380 in. (9).....	1	All	6 10
110036-58	Chain, magneto, 58 Links, $\frac{3}{8}$ in. by .225 in. (10).....	1	All	6 11
110036-47	Chain, dynamo, 47 Links, $\frac{3}{8}$ in. by .225 in. (10).....	1	All	5 8
110046-26	Link, connecting, for $\frac{3}{8}$ in. chains.....	-	All	5
110056-26	Link, connecting, for $\frac{1}{2}$ in. chains.....	-	All	7 $\frac{1}{2}$
110046-30	Link, cranked, for $\frac{1}{2}$ in. chains.....	-	All	9
110056-30	Link, cranked, for $\frac{3}{8}$ in. chains.....	-	All	1 1
110046-27	Clip, spring, for $\frac{1}{2}$ in. connecting links.....	-	All	1
110056-27	Clip, spring, for $\frac{3}{8}$ in. connecting links.....	-	All	1 $\frac{1}{2}$

NOTE 9.—The prices of front and rear chains include spring connecting links and these are also included in the number of links per chain. We do not sell odd lengths of chains.

NOTE 10.—Magneto and Dynamo chains are endless. We do not sell connecting and cranked links for same.

### GEAR BOX SHELL.

1-CP-16	Shell gear box, bare.....	1	All	2 2 0
60-X-6	Stud, gear box shell, 1 $\frac{1}{4}$ in. by $\frac{3}{8}$ in.....	2	All	9
60-X-9	Stud, gear box shell, 3 $\frac{1}{8}$ in. by $\frac{3}{8}$ in.....	2	All	9
60-X-1	Stud, gear box shell, 1 in. by $\frac{1}{2}$ in.....	2	All	9
152-X	Nut, for $\frac{1}{4}$ in. gear box shell stud.....	4	All	4
63-X	Nut, for $\frac{3}{8}$ in. gear box shell stud.....	2	All	3
348-X	Plug, drain, for gear box shell.....	1	All	9
3-C-7	Case, kick-starter.....	1	All	1 2 6
2-1C	Washer, paper, for kick-starter case.....	1	All	1
286-X	Stud, kick-starter case, 2 $\frac{1}{2}$ in. by $\frac{1}{2}$ in.....	3	All	9
63-X	Nut, for $\frac{3}{8}$ in. kick-starter case stud.....	3	All	3
245-X-2	Nipple, grease, for kick-starter case.....	1	All	4
4-C-8	Cover, for kick-starter case.....	1	All	1 2 6
4-1C-2	Washer, paper, for kick-starter case cover.....	1	All	1
326-X	Cap, filler, for kick-starter case cover.....	1	All	3 0

### GEAR BOX FIXING BOLTS.

STD-313	Bolt, gear box top fixing, 4 $\frac{1}{2}$ in. by $\frac{1}{2}$ in.....	1	350	9
39-G9-G59	Bolt, gear box top fixing, 5 $\frac{1}{8}$ in. by $\frac{1}{2}$ in.....	1	500	10
STD-312	Bolt, gear box bottom fixing, 3 $\frac{1}{2}$ in. by $\frac{1}{2}$ in.....	1	350	9
STD-313	Bolt, gear box bottom fixing, 4 $\frac{1}{2}$ in. by $\frac{1}{2}$ in.....	1	500	9
STD-632	Spacer, on top bolt, outside, right.....	1	All	4
39-G9-G61	Spacer, on top bolt, inside, left and right.....	2	500	4
39-G9-G61	Spacer, on bottom bolt, inside, left and right.....	2	500	4
STD-2	Nut, gear box top fixing bolt.....	2	All	4
STD-2	Nut, gear box bottom fixing bolt.....	2	All	4
STD-9	Washer, plain, top fixing bolt, left side.....	1	All	1
STD-594	Eye-bolt, front chain adjustment.....	1	All	9
STD-215	Nut, front, chain adjustment eye-bolt.....	2	All	4
STD-785	Crosshead, front chain adjustment eye-bolt.....	1	All	6
STD-361	Bolt, fixing crosshead to engine plate.....	1	All	3
STD-11	Washer, plain, crosshead fixing bolt.....	1	All	1

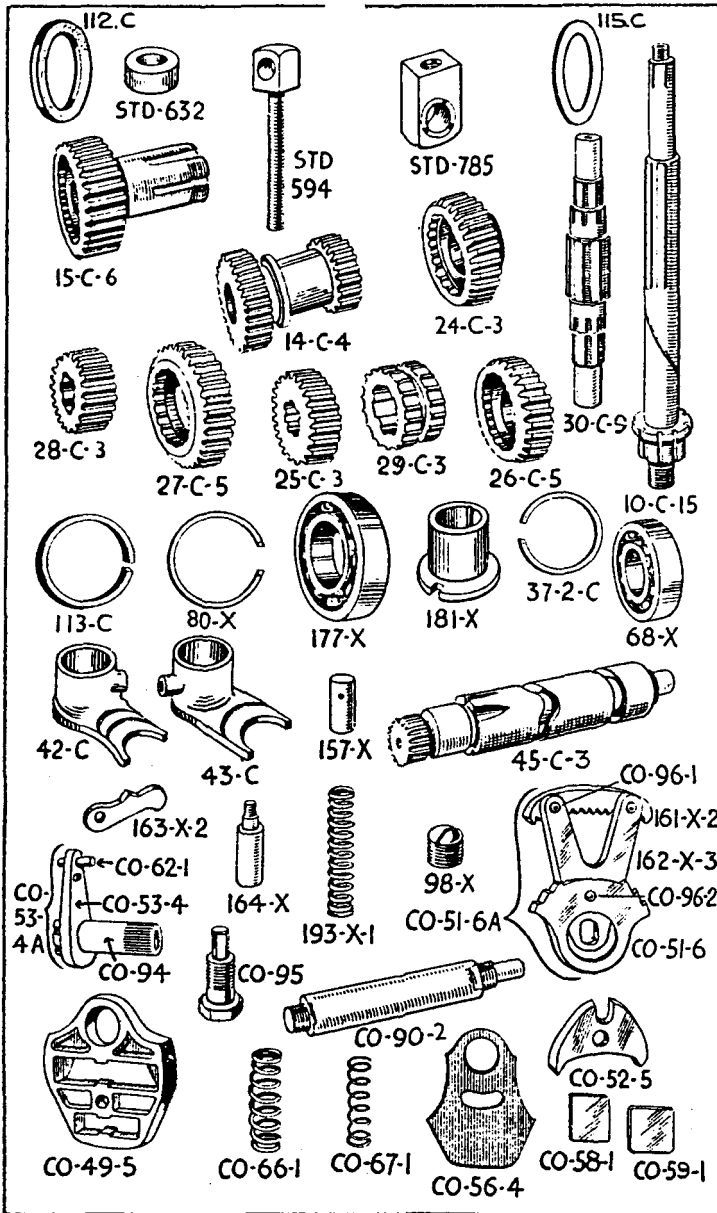

P NUMBER.	DESCRIPTION.	QTY.	USED ON.	PRICE EACH £ s. d.
<b>SHAFTS AND GEARS.</b>				
10-C-15	Mainshaft, gear box, 10½ in. overall length.....	1	All	1 18 3
15-C-6	Gear, driving, mainshaft, with bushes, 30 teeth...	1	All	2 8 0
187-X-3	Bush, only, mainshaft driving gear.....	2	All	3 0 0
14-C-4	Gear, sliding, mainshaft, 18 23 teeth.....	1	All	2 5 0
24-C-3	Gear, third, on mainshaft, 27 teeth.....	1	All	18 9
30-C-9	Layshaft, bare, gear box.....	1	All	1 10 0
28-C-3	Gear, small, on layshaft, 20 teeth.....	1	All	15 0
27-C-5	Gear, first, on layshaft, 32 teeth.....	1	All	18 9
26-C-5	Gear, second, on layshaft, 27 teeth.....	1	All	18 9
25-C-3	Gear, third, on layshaft, 23 teeth.....	1	All	15 0
29-C-3	Clutch, sliding, on layshaft.....	1	All	15 0

### GEAR BOX BEARINGS.

177-X	Ball bearing, driving gear (11).....	1	All	1 2 6
112-C	Washer, felt, main driving gear bearing.....	1	All	9
115-C	Washer, dished, driving gear bearing (12).....	1	All	6
80-X	Ring, split, retaining bearing in shell.....	1	All	9
114-C	Washer, outer, driving gear bearing (13).....	1	All	4
113-C	Ring, split, retaining bearing outer washer.....	1	All	6
68-X	Ball bearing, mainshaft, K-S end (14).....	1	All	18 9
37-1-C-2	Washer, gland, mainshaft ball bearing (15).....	1	All	9
37-2-C	Ring, split, retaining mainshaft ball bearing.....	1	All	6
181-X	Bush, for layshaft.....	2	All	6 0
87-X	Peg, locating layshaft bush.....	2	All	1
182-X	Cap, covering layshaft bush in gear box shell.....	1	All	3

NOTE 11.—Dimensions 1½ in. by 62 mm. by 16 mm. (177-X).

NOTE 12.—Dimensions 1½ in. by 2 in. (115-C).

NOTE 13.—Dimensions 1½ in. by 2½ in. (114-C).

NOTE 14.—Dimensions 12 mm. by 40 mm. by 17 mm. (68-X).

NOTE 15.—Dimensions 1½ in. by 1½ in. (37-1-C-2).

### GEAR OPERATING PARTS.

42-C	Fork, operating mainshaft sliding gear.....	1	All	12 0
43-C	Fork, operating layshaft sliding clutch.....	1	All	12 0
157-X	Peg, operating layshaft sliding clutch.....	2	All	9
158-X	Pin, split, operating fork peg.....	2	All	1
45-C-3	Camshaft, bare, for gear box.....	1	All	1 17 6
159-X	Bush, for camshaft, in gear box shell.....	1	All	3 0
163-X-2	Pawl, engages in gear box camshaft.....	1	All	3 0
164-X	Pin, bearing, for camshaft pawl.....	1	All	1 10
95-X	Nut, for camshaft pawl bearing pin.....	1	All	4
193-X-1	Spring, for camshaft pawl.....	1	All	1 1
98-X	Plug, screwed, retaining camshaft pawl spring.....	1	All	1 6
162-X-3	Quadrant, gear selection.....	1	All	5 3
161-X-2	Sector, gear selection, engages camshaft.....	1	All	6 0
CO-51-6	Ratchet, gear selection.....	1	All	5 3
CO-51-6-A	Quadrant, sector and ratchet, assembled.....	1	All	17 3
CO-96-1	Rivet, fixing camshaft sector to quadrant.....	2	All	1
CO-96-2	Rivet, fixing camshaft ratchet to quadrant.....	1	All	1
CO-90-2	Spindle, for gear selection quadrant.....	1	All	5 3
287-X	Nut (inside), gear selection quadrant spindle.....	1	All	3
CO-91	Bush, in kick-starter case, for control spindle.....	1	All	1 6
160-X-3	Bush, in kick-starter case, for camshaft.....	1	All	4 6
CO-53-4	Quadrant, for foot gear control.....	1	All	4 6
CO-94	Sleeve, for foot gear control quadrant.....	1	All	11 3
CO-62-1	Peg, for gear indexing pawl.....	1	All	4
CO-53-4-A	Quadrant, assembled with sleeve and peg.....	1	All	16 2

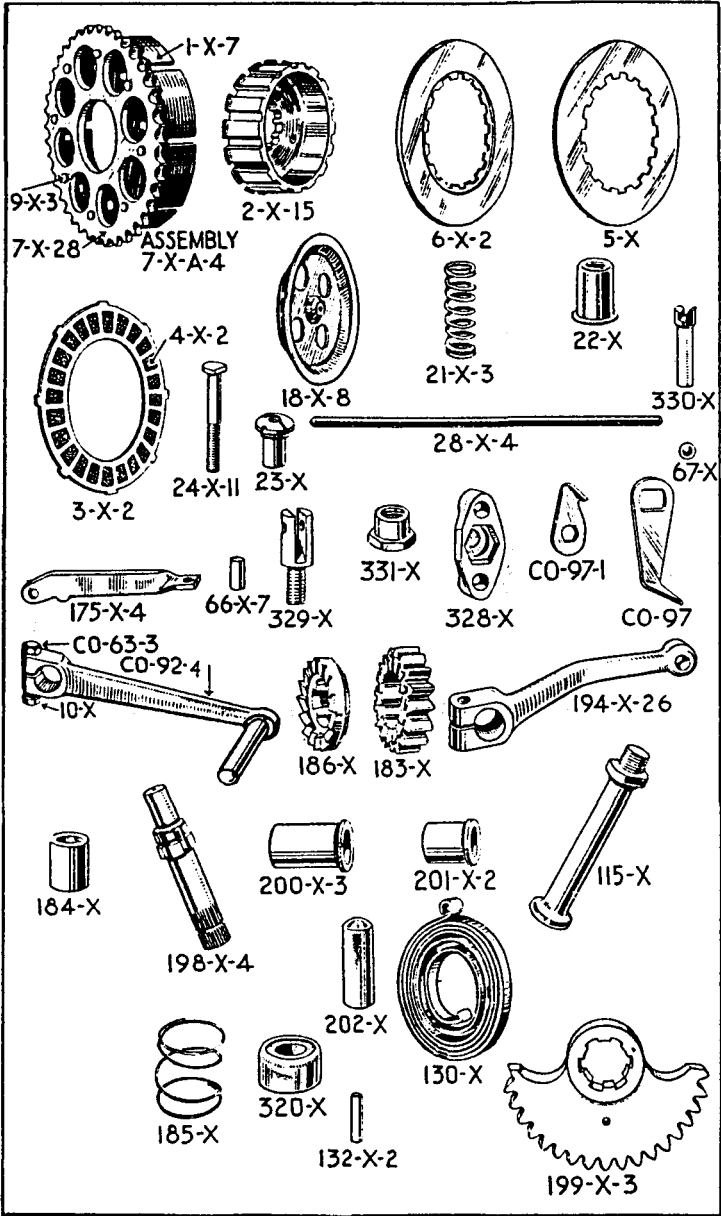

## GEAR OPERATING PARTS—continued.

CO-54-7	...	...	Bush, for foot control quadrant sleeve.....	1	...	All	...	7	6
CO-95	...	...	Bolt, fixing quadrant sleeve bush in K-S cover.....	1	...	All	...	1	10
CO-52-5	...	...	Pawl, indexing, for foot gear control.....	1	...	All	...	2	3
CO-60-1	...	...	Spindle, for gear control indexing pawl.....	1	...	All	...	7	4
CO-49-5	...	...	Box, spring, for foot gear control.....	1	...	All	...	7	6
CO-56-4	...	...	Plate, cover, for foot gear control spring box.....	1	...	All	...	1	6
CO-66-1	...	...	Spring, main, for control box (large spring).....	2	...	All	...	9	9
CO-67-1	...	...	Spring, pawl, for control box (small spring).....	2	...	All	...	9	9
CO-59-1	...	...	Plate, for control box main spring.....	2	...	All	...	3	3
CO-58-1	...	...	Plate, for control box pawl spring.....	2	...	All	...	3	3

## CLUTCH.

1-X-7	...	...	Case, for clutch (for four plates).....	1	...	350	...	18	0
1-X-8	...	...	Case, for clutch (for five plates).....	1	...	500	...	18	0
9-X-3	...	...	Rivet, for clutch case and chainwheel.....	8	...	All	...	1	1
7-X-A-4	...	...	Chainwheel and clutch case, assembled.....	1	...	350	...	2	9
7-X-A-5	...	...	Chainwheel and clutch case, assembled.....	1	...	500	...	2	9

For the bore chainwheel and its roller bearing, see CLUTCH SPROCKET, in the transmission Section, page 16.

2-X-15	...	...	Centre, for four plate clutch.....	1	...	350	...	1	10
2-X-16	...	...	Centre, for five plate clutch.....	1	...	500	...	1	10
69-X	...	...	Nut, retaining centre to mainshaft.....	1	...	All	...	9	9
71-X	...	...	Washer, plain, for centre retaining nut.....	1	...	All	...	4	4
212-X	...	...	Washer, spring, for centre retaining nut.....	1	...	All	...	4	4
6-X-2	...	...	Plate, clutch, plain, steel, thick.....	1	...	All	...	3	9
5-X	...	...	Plate, clutch, plain, steel, thin.....	4	...	350	...	3	0
5-X	...	...	Plate, clutch, plain, steel, thin.....	5	...	500	...	3	0
3-X-2	...	...	Plate, clutch, friction, with inserts.....	4	...	350	...	7	6
3-X-2	...	...	Plate, clutch, friction, with inserts.....	5	...	500	...	7	6
4-X-2	...	...	Inserts, fabric, for friction plate, per dozen.....	96	...	350	...	1	1
4-X-2	...	...	Inserts, fabric, for friction plate, per dozen.....	120	...	500	...	1	1
18-X-8	...	...	Plate, spring pressure, for clutch.....	1	...	All	...	13	6
21-X-3	...	...	Spring, for clutch.....	4	...	All	...	9	9
22-X	...	...	Cup, for clutch spring.....	4	...	All	...	9	9
24-X-11	...	...	Stud, for clutch spring, four plate clutch.....	4	...	350	...	6	6
24-X-12	...	...	Stud, for clutch spring, five plate clutch.....	4	...	500	...	6	6
23-X	...	...	Nut, adjusting, for clutch spring.....	4	...	All	...	6	6

## CLUTCH OPERATING PARTS.

28-X-4	...	...	Rod, thrust, for four plate clutch, 9½ in.....	1	...	350	...	1	6
28-X-5	...	...	Rod, thrust, for five plate clutch, 10½ in.....	1	...	500	...	1	6
330-X	...	...	Plunger, clutch operating.....	1	...	All	...	9	9
67-X	...	...	Ball, steel, for clutch operating plunger.....	1	...	All	...	1	1
175-X-4	...	...	Lever, clutch operating.....	1	...	All	...	3	0
66-X-7	...	...	Pin, for clutch operating lever.....	1	...	All	...	1	1
329-X	...	...	Fork, for clutch operating lever.....	1	...	All	...	2	3
331-X	...	...	Sleeve, for clutch operating lever fork.....	1	...	All	...	9	9
328-X	...	...	Cap, covering clutch operating lever fork sleeve.....	1	...	All	...	2	3
333-X	...	...	Screw, fixing sleeve cap to kick-starter case cover.....	2	...	All	...	6	6

## GEAR CONTROL PARTS.

CO-97-1	...	...	Indicator, gear, fixed.....	1	...	All	...	4	4
CO-97	...	...	Indicator, gear, moving.....	1	...	All	...	9	9
287-X	...	...	Nut, retaining moving gear indicator.....	1	...	All	...	3	3
CO-92-4	...	...	Lever, foot, gear control.....	1	...	All	...	11	3
CO-63-3	...	...	Bolt, clamping gear foot lever to sleeve.....	1	...	All	...	1	1
10-X	...	...	Nut, for gear foot lever clamping bolt.....	1	...	All	...	3	3

## KICK-STARTER.

186-X	...	...	Ratchet, driving, kick-starter.....	1	...	All	...	8	7
183-X	...	...	Pinion, ratchet, kick-starter.....	1	...	All	...	12	0
184-X	...	...	Bush, kick-starter ratchet pinion.....	1	...	All	...	3	9
185-X	...	...	Spring, kick-starter ratchet pinion.....	1	...	All	...	1	1
70-X	...	...	Nut, retaining driving ratchet to mainshaft.....	1	...	All	...	6	6
198-X-4	...	...	Spindle, for kick-starter quadrant and foot lever.....	1	...	All	...	11	3
201-X-2	...	...	Bush, in K-S, case for K-S quadrant spindle.....	1	...	All	...	3	0
200-X-3	...	...	Bush, in K-S case cover, for K-S quadrant spindle.....	1	...	All	...	3	0
199-X-3	...	...	Quadrant, for kick-starter spindle.....	1	...	All	...	15	9
199-X-3-A	...	...	Kick-starter quadrant and spindle, assembled.....	1	...	All	...	1	7
130-X	...	...	Spring, return, for kick-starter foot lever.....	1	...	All	...	3	0
132-X-2	...	...	Pin, anchor, for kick-starter return spring.....	1	...	All	...	4	4
202-X	...	...	Stop rubber and sleeve, for K-S quadrants.....	1	...	All	...	9	9
194-X-26	...	...	Peg, for K-S stop rubber and sleeve.....	1	...	All	...	9	9
115-X	...	...	Lever, foot, kick-starter, bare.....	1	...	All	...	15	9
315-X	...	...	Pin, pedal, for kick-starter foot lever.....	1	...	All	...	4	6
109-X	...	...	Bolt, clamping K-S foot lever to spindle.....	1	...	All	...	1	1
144-X	...	...	Washer, spring, for K-S foot lever bolt.....	1	...	All	...	1	1
	...	...	Nut, for K-S foot lever clamping bolt.....	1	...	All	...	9	9

## FRAME SECTION.

PART NUMBER.	DESCRIPTION.	QTY.	USED ON.	PRICE EACH £ s. d.
<b>FRAME.</b>				
41-G3L-F23 ... ..	Frame, front portion only, bare.....	1 ...	All ...	4 17 6
41-G3L-F24 ... ..	Frame, rear portion only, bare.....	1 ...	All ...	4 14 6
STD-S97 ... ..	Bolt, for seat lug (below saddle).....	1 ...	All ...	9
STD-15 ... ..	Screw, securing earth wires (Screws into end of bolt STD-S97).....	1 ...	All ...	1
STD-185 ... ..	Washer, plain, for earth wire screw.....	1 ...	All ...	1
STD-8 ... ..	Washer, plain, for seat lug bolt.....	2 ...	All ...	1
STD-1 ... ..	Nut, for seat lug bolt.....	2 ...	All ...	4
STD-302 ... ..	Bolt, for seat tube bottom lug.....	1 ...	350 ...	4
STD-303 ... ..	Bolt, for seat tube bottom lug.....	1 ...	500 ...	6
STD-3 ... ..	Nut, for seat tube bottom lug bolt.....	2 ...	All ...	3
011231... ..	Spacer, for seat tube bottom lug bolt.....	2 ...	500 ...	6
STD-280 ... ..	Bolt, uniting front and rear frame.....	1 ...	350 ...	6
011238... ..	Bolt, uniting front and rear frame.....	1 ...	500 ...	6
STD-11 ... ..	Washer, plain, for frame uniting bolt.....	2 ...	All ...	1
40-G3-F66 ... ..	Spacer, for frame uniting bolt.....	2 ...	350 ...	6
STD-4 ... ..	Nut, for frame uniting bolt.....	2 ...	All ...	3
41-G3L-F32 ... ..	Bolt, adjusting, rear chain.....	2 ...	All ...	1 1
STD-5 ... ..	Nut, for rear chain adjusting bolt.....	2 ...	All ...	3
STD-51 ... ..	Nipple, grease, for head lug.....	1 ...	All ...	3
STD-806 ... ..	Ball race, for frame head lug.....	2 ...	All ...	3 6
STD-72 ... ..	Set of balls, $\frac{3}{8}$ in. diameter, for steering head.....	56 ...	All ...	1 6
41-G3L-E250-L ... ..	Plate, engine, rear, left side.....	1 ...	350 ...	9 0
011264... ..	Plate, engine, rear, left side.....	1 ...	500 ...	9 0
41-G3L-E250-R ... ..	Plate, engine, rear, right side.....	1 ...	350 ...	9 0
011264... ..	Plate, engine, rear, right side.....	1 ...	500 ...	9 0
41-G3L-E550 ... ..	Plate, engine, front.....	1 ...	All ...	4 6
STD-303 ... ..	Bolt, fixing front plate to frame tube.....	1 ...	All ...	6
STD-10 ... ..	Washer, plain, for front engine plate bolt.....	2 ...	All ...	1
STD-3 ... ..	Nut, for bolt fixing front engine plate.....	2 ...	All ...	3

### **FORK ASSEMBLIES.**

42-G3L-FF1 ... .. Front fork assembly..... 1 ... All ... 13 6 0

*A front fork assembly comprises all the parts listed in the FRONT FORK group on page 25, except the speedometer head bracket with its two fixing washers and bolts.*

*For ease of servicing, the two main fork units are listed, and supplied, as separate assemblies. These enable a complete assembly to be exchanged in minimum time. They are listed below.*

41-G3L-FF201... .. Front fork inner tube assembly..... 2 ... All ... 2 11 0

*The above assembly comprises all those parts in the FRONT FORK, page 25, that are marked A.*

41-G3L-FF202... .. Front fork damper tube assembly..... 2 ... All ... 7 6

*The above assembly fits inside the inner tube assembly and comprises all those parts in the FRONT FORK that are marked B.*

PART NUMBER.	DESCRIPTION.	QTY.	USED ON.	PRICE EACH £ s. d.
<b>FRONT FORK.</b>				
42-G3L-FF17 ...	Crown, front fork.....	1	All	1 0 3
41-18-FF20 ...	Stem, fork crown.....	1	All	6 0
41-18-FF20 ...	Stem, fork crown.....	1	All	6 0
40-G12M-FF92 ...	Circlip, for fork crown stem.....	1	All	1
42-G3L-FF17-A ...	Crown assembly, comprising above 3 parts.....	1	All	1 6 4
STD-805 ...	Ball race, for fork crown.....	1	All	4 9
STD-369 ...	Bolt, pinch, for fork crown.....	2	All	4
STD-11 ...	Washer, plain, for fork crown pinch bolt.....	2	All	1
42-G3L-FF21 ...	Lug, for handlebar and steering head.....	1	All	1 9 3

The above handlebar lug includes the handlebar half clip and its studs with washers and nuts. For the part numbers and prices of those items see HANDLEBAR, below.

STD-806 ...	Ball race, for handlebar lug.....	1	All	3 6
STD-51 ...	Nipple, grease, for handlebar lug.....	1	All	3
STD-236 ...	Nut, adjusting, for fork crown stem.....	1	All	1 0
L4-FF46 ...	Nut, lock (domed), for fork crown stem.....	1	All	2 3
41-G3L-FF3 ...	Tube, fork inner.....	2	All	1 4 9
40-G12M-FF191 ...	Bush, bottom, fork inner tube.....	2	All	3 9
40-G12M-FF192 ...	Circlip, fork inner tube bottom bush.....	2	All	1 1
40-G12M-FF189 ...	Bolt, top, fork inner tube.....	2	All	1 1
40-G12M-FF190 ...	Washer, plain, fork inner tube top bolt.....	2	All	4
40-G12M-FF183-L ...	Slider, fork, left side, with cap. studs and nuts ...	1	All	1 17 6
40-G12M-FF183-R ...	Slider, fork, right side, with cap. studs and nuts ...	1	All	1 13 0
40-G12M-FF183-C ...	Cap, for slider, left or right.....	2	All	3 9
40-G12M-FF185-A ...	Extension, for fork slider.....	2	All	6 9
40-G12M-FF41 ...	Bush, bakelite, guide, fork inner tube.....	2	All	2 6
40-G12M-FF91 ...	Oil seal, for fork inner tube.....	2	All	4 10
40-G12M-FF95 ...	Washer, paper, for inner tube oil seal.....	2	All	1
41-G3L-FF32 ...	Spring, for front fork.....	2	All	9 0
40-G12M-FF126 ...	Washer, leather, fork spring seating.....	4	All	3
41-G3L-FF184-T ...	Tube, fork cover, top.....	2	All	2 7
40-G12M-FF186 ...	Cap, for fork top cover tube.....	2	All	1 1
40-G12M-FF128 ...	Plate, threaded, locating top cover tube.....	2	All	6
41-G3L-FF184-B ...	Tube, fork cover, bottom.....	2	All	3 0
40-G12M-FF127 ...	Plate, plain, locating bottom cover tube.....	2	All	3
40-G12M-FF129 ...	Screw, retaining both locating plates.....	6	All	3
STD-485 ...	Screw, plug, oil level, fork slider.....	2	All	1
STD-203 ...	Washer, fibre, fork slider oil level screw.....	2	All	1
41-G3L-FF55 ...	Rod, for fork damper.....	2	All	1 6
STD-4 ...	Nut, lock, top end of damper rod.....	2	All	3
STD-11 ...	Washer, for damper rod lock nut.....	2	All	1
40-G12M-FF60-K ...	Tube, fork damper.....	2	All	4 0
40-G12M-FF56 ...	Sleeve, plunger, fork damper rod.....	2	All	6
40-18-FF58 ...	Valve, for fork damper.....	2	All	6
40-18-FF57 ...	Seat, for fork damper valve.....	2	All	1
40-18-FF59 ...	Pin, stop, for fork damper valve.....	2	All	1
STD-5 ...	Nut, lock, fork damper tube valve.....	2	All	3
40-G12M-FF93 ...	Clip, retaining damper rod sleeve.....	2	All	1
40-G12M-FF80 ...	Washer, fibre, damper tube bolt.....	2	All	1
40-G12M-FF94 ...	Bolt, fixing damper tube to slider.....	2	All	7
40-G12M-FF78 ...	Bracket, for speedometer head.....	1	All	9
STD-342 ...	Bolt, fixing speedometer bracket.....	2	All	3
STD-12 ...	Washer, plain, speedometer bracket bolt.....	2	All	1
40-G12M-FF195 ...	Stud, securing fork slider cap.....	4	All	4
STD-4 ...	Nut, fork slider securing stud.....	4	All	3

## HANDLEBAR.

40-G2M-FF66 ...	Handlebar, bare.....	1	All	18 9
41-G3L-FF21-C ...	Clip, half only, for handlebar lug.....	1	All	1 10
40-G2M-FF65 ...	Stud, for handlebar clip.....	2	All	4
STD-11 ...	Washer, plain, handlebar clip stud.....	2	All	1
STD-4 ...	Nut, handlebar clip stud.....	2	All	3

PART NUMBER.	DESCRIPTION.	QTY.	USED ON.	PRICE EACH £ s. d.
--------------	--------------	------	----------	-----------------------

### FRONT STAND.

12403 ...	Stand, front, bare.....	1	All	7 6
41-G3L-FF421...	Bolt, fixing stand to right slider.....	1	All	9
41-G3L-FF422...	Bolt, fixing stand to left slider.....	1	All	9
HBD-52 ...	Washer, spring, front stand fixing bolt.....	2	All	3
STD-14 ...	Pin, split, front stand fixing bolt.....	2	All	1
STD-344 ...	Bolt, fixing front stand to front guard.....	1	All	6
STD-12 ...	Washer, plain, front stand guard bolt.....	1	All	1
STD-211 ...	Nut (with collar), front stand guard bolt.....	1	All	4
STD-5 ...	Nut, lock, front stand guard bolt.....	1	All	3

### REAR STAND.

38-G3-F44 ...	Stand, rear, bare.....	1	All	1 9 3
38-12-F71 ...	Bolt, fixing, stand to fork end.....	2	All	9
STD-8 ...	Washer, plain, rear stand fixing bolt.....	2	All	1
STD-71 ...	Nut, rear stand fixing bolt.....	2	All	4
38-G3-F245 ...	Spring, return, rear stand.....	1	All	2 3

### PROP STAND.

35-G3-F342 ...	Stand, prop, bare.....	1	All	11 3
35-G3-F341 ...	Bolt, hinge, prop stand leg.....	1	All	6
STD-2 ...	Nut, prop stand hinge bolt.....	1	All	4
35-G3-F345 ...	Spring, return, prop stand.....	1	All	9

### FRONT MUDGUARD.

010921...	Mudguard, front, bare.....	1	All	18 9
41-G3L-M38 ...	Bolt, fixing mudguard bracket to slider.....	4	All	4
STD-192 ...	Washer, spring, mudguard bracket bolt.....	4	All	1
42-G3L-M30 ...	Stay, front mudguard.....	2	All	1 0
41-G3L-M38 ...	Bolt, fixing stay to fork slider.....	2	All	4
STD-192 ...	Washer, spring, stay to fork slider bolt.....	2	All	1
STD-70 ...	Bolt, fixing stay to front mudguard.....	2	All	3
STD-191 ...	Washer, spring, stay to front mudguard bolt.....	2	All	1
STD-12 ...	Washer, plain, stay to front mudguard bolt.....	2	All	1
STD-5 ...	Nut, stay to front mudguard bolt.....	2	All	3

### REAR MUDGUARD.

010901...	Mudguard, rear, bare.....	1	All	1 10 0
-----------	---------------------------	---	-----	--------

*Although the above mudguard is made in two pieces the parts are not sold as separate spares.*

STD-5 ...	Nut, uniting halves of rear mudguard.....	2	All	3
STD-12 ...	Washer, plain, for mudguard uniting bolt.....	2	All	1
STD-345 ...	Bolt, fixing mudguard to frame bridges.....	2	All	4
STD-191 ...	Washer, spring, mudguard bridge bolt.....	2	All	1
STD-5 ...	Nut, rear mudguard bridge bolt.....	2	All	3
STD-370 ...	Bolt, fixing guard to oil tank bracket.....	1	All	4
4178 ...	Spacer, thick, oil tank bracket bolt.....	1	All	6
4178-5 ...	Spacer, thin, oil tank bracket bolt.....	1	All	6
STD-11 ...	Washer, plain, oil tank bracket bolt.....	1	All	1
STD-4 ...	Nut, oil tank bracket bolt.....	1	All	3
41-G3L-F300-L-P	Stay, rear mudguard, left side.....	1	All	14 6
41-G3L-F300-R-P	Stay, rear mudguard, right side.....	1	All	14 6
STD-270 ...	Stud, in fork end, for mudguard stay.....	2	All	3
STD-74 ...	Nut, locking stud in fork end.....	2	All	3
STD-213 ...	Nut, (with collar), locking rear mudguard stay to fork end stud.....	2	All	4
STD-363 ...	Bolt, fixing mudguard to rear of stay.....	2	All	4
STD-363 ...	Bolt, fixing mudguard to front stay of, left side ...	1	All	4
9TD-364 ...	Bolt, fixing mudguard to front of stay, right side, also secures tool box stay.....	1	All	6
STD-192 ...	Washer, spring, mudguard stay bolt.....	4	All	1
STD-4 ...	Nut, rear mudguard stay bolt.....	4	All	3



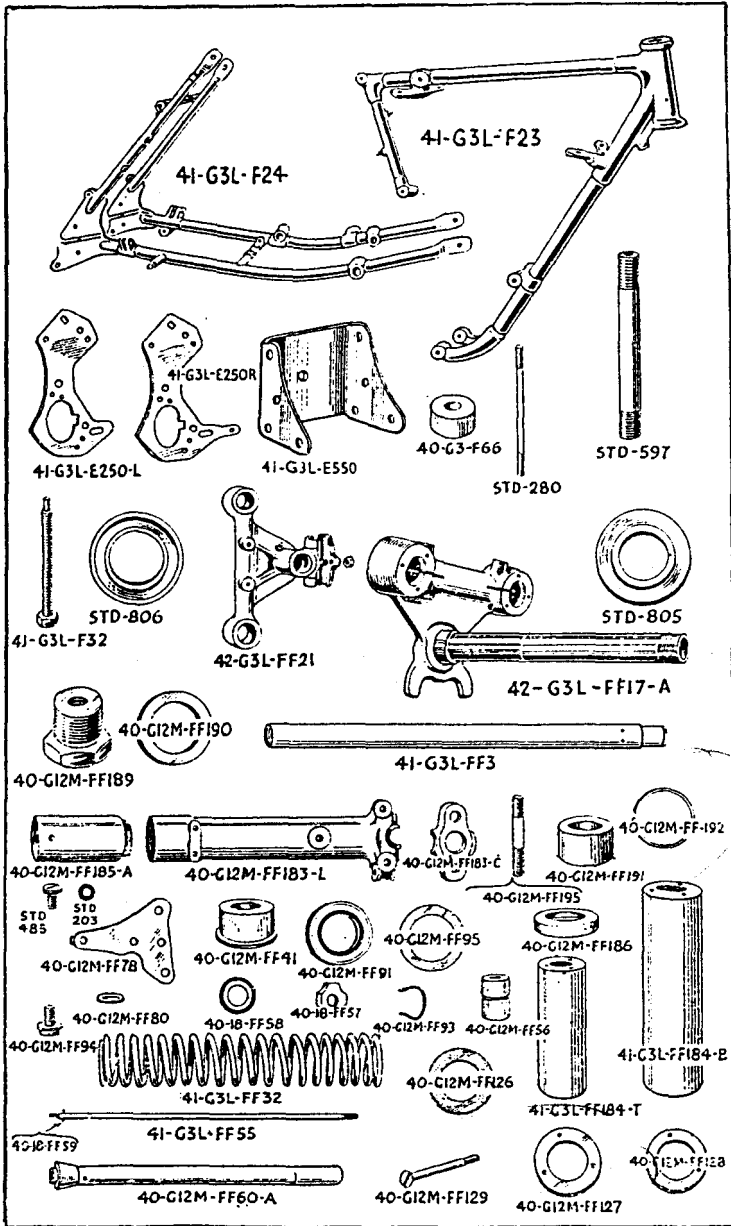

PART NUMBER.	DESCRIPTION.	QTY.	USED ON.	PRICE EACH £ s. d.
--------------	--------------	------	----------	-----------------------

### LIFTING HANDLE.

011038...	Handle, lifting, bare (16).....	1	All	7 0
STD-70	Bolt, fixing lifting handle.....	2	All	3
STD-12	Washer, plain, lifting handle bolt.....	4	All	1
STD-5	Nut, lifting handle fixing bolt.....	2	All	3

NOTE 16.—The lifting handle must be discarded if a rear carrier is fitted.

### REAR CARRIER.

41-G3L-EQ40-P	Carrier, rear, bare (17).....	1	All	1 0 3
---------------	-------------------------------	---	-----	-------

NOTE 17.—This is an optional extra and, if fitted, the lifting handle must be discarded. If Pannier equipment (page 46) is fitted a rear carrier is then essential.

### FRONT NUMBER PLATE.

STD-741	Plate, number, front.....	1	All	2 7
STD-742	Clip, with washer and nut, front plate.....	2	All	6
STD-451	Screw, fixing front plate to clip.....	2	All	3
STD-80	Nut, front plate fixing screw.....	2	All	1

### REAR NUMBER PLATE.

STD-744	Plate, number, rear.....	1	All	6 9
STD-70	Bolt, fixing rear plate to mudguard.....	4	All	3
STD-12	Washer, plain, rear plate fixing bolt.....	4	All	1
STD-5	Nut, rear number plate fixing bolt.....	4	All	3
39-G3-EQ13	Bush, rubber, rear lamp cable.....	1	All	4

### FRONT CHAINCASE.

35-G3-C-A	Chaincase, complete (18).....	1	All	2 12 6
35-G3-C1	Chaincase, back half, bare.....	1	All	18 9
20817-1	Chaincase, front half, bare.....	1	All	1 4 0
12302-7	Band, metal, for chaincase.....	1	All	7 6 4
STD-452	Screw, clamping chaincase metal band.....	1	All	3
12302-9	Band, rubber, for chaincase.....	1	All	9
17350-1	Cap, assembly, chaincase inspection (19).....	1	All	2 0
STD-580	Washer, cork, chaincase inspection cap.....	1	All	3
STD-440	Bolt, fixing chaincase to engine.....	3	All	3
STD-165	Washer, lock, chaincase engine bolt.....	3	All	3
STD-315	Bolt, fixing centre of chaincase.....	1	350	1 1
STD-316	Bolt, fixing centre of chaincase (20).....	1	500	1 1
20841	Spacer, centre bolt, between plates, 2½ in.....	1	350	6
20841-L	Spacer, centre bolt, between plates, 3½ in.....	1	500	6
40-G2M-C27	Spacer, centre bolt, between chaincase and engine plate 1 <sup>11</sup> / <sub>16</sub> in.....	1	350	4
39-G9-C27	Spacer, centre bolt, between chaincase and engine plate 1½ in.....	1	500	4
35-2-C29	Spacer, centre bolt, inside case ¾ in.....	1	All	9
STD-9	Washer, plain, chaincase centre bolt.....	2	All	1
STD-2	Nut, chaincase centre bolt.....	3	All	4

NOTE 18.—"Chaincase, complete" comprises, Back and front halves of chaincase, metal band with rubber band and clamping screw and complete inspection cap. NO FIXING BOLTS, SPACERS, WASHERS AND NUTS ARE INCLUDED.

NOTE 19.—A "Cap, assembly" comprises the cap with its central screw, back plate and cork washer. The cap, central screw and back plate are not sold as separate spares because the central screw is "buried" after assembly.

NOTE 20.—Also see crankcase bolts

### REAR CHAINGUARD.

40-G2M-C10	Chainguard, rear, bare.....	1	All	1 6 3
36-8-C28	Bolt, fixing top of chainguard in front.....	1	All	6

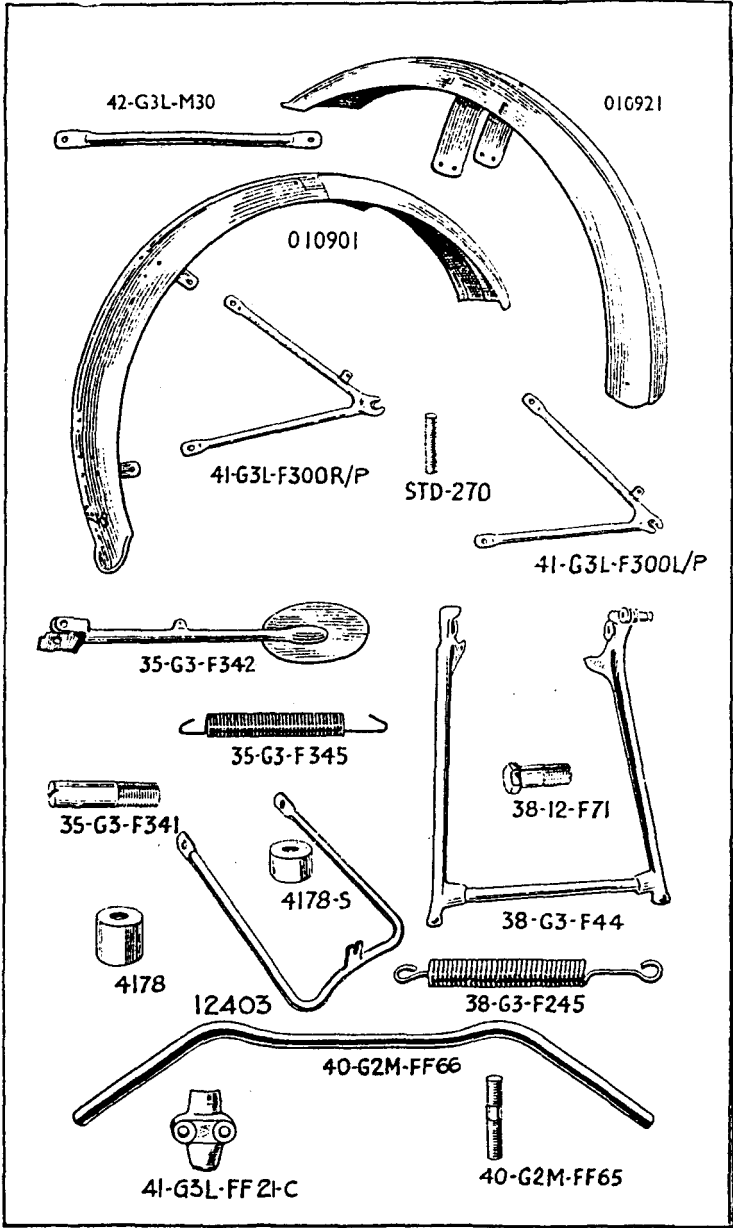

STD-70	...	Bolt, fixing bottom of chainguard in front.....	1	All	3
STD-12	...	Washer, plain, bottom front bolt.....	1	All	1
STD-5	...	Nut, bottom, front chaingua lt.....	1	All	3
STD-363	...	Bolt, fixing rear of chainguar.....	1	All	4
STD-11	...	Washer, plain, for chainguard rear bolt.....	1	All	1

### BATTERY CARRIER.

36-G3-E185	...	Carrier, battery, complete (21).....	1	All	12	6
36-G3-E181-A	...	Carrier, battery, back portion only.....	1	All	6	0
39-G3-E182	...	Carrier, battery, front portion only.....	1	All	5	0
X-E184	...	Pin, hinge, battery carrier front.....	1	All	3	
A-E180	...	Bolt, clamping, battery carrier.....	1	All	6	
A-E178	...	Seat, battery carrier clamping bolt.....	1	All	4	
A-E177	...	Nut, battery carrier clamping bolt.....	1	All	7	
STD-4	...	Nut, fixing carrier to main frame (22).....	2	All	3	
STD-174	...	Washer, plain, carrier fixing nut (22).....	2	All	3	
D-E181-B	...	Stay, battery carrier to chaincase.....	1	All	9	
STD-40	...	Screw, fixing stay to battery carrier.....	1	All	1	
STD-12	...	Washer, plain, battery stay screw.....	1	All	1	

NOTE 21.—“Carrier, battery, complete,” includes front and back portions, hinge pin and clamping bolt with seat and nut.

NOTE 22.—Also serves to retain the oil tank to the main frame.

### TOOL BOX.

011164	...	Box, tool, bare (23).....	1	All	18	9
37-B-F53	...	Screw, knurled, for tool box lid.....	1	All	1	6
STD-189	...	Washer, spring, tool box lid screw.....	1	All	1	
STD-5	...	Nut, tool box lid screw.....	2	All	3	
STD-363	...	Bolt, fixing tool box to seat stay.....	2	All	4	
R-C28	...	Spacer, tool box seat stay bolt.....	2	All	4	
STD-11	...	Washer, plain, tool box seat stay bolt.....	2	All	1	
STD-4	...	Nut, tool box seat stay bolt.....	2	All	3	
STD-5	...	Nut, tool box fixing bolt.....	4	All	3	
40-G3-F158	...	Stay, for tool box.....	1	All	9	
STD-361	...	Bolt, fixing stay to tool box.....	1	All	3	
STD-11	...	Washer, plain, tool box stay bolt.....	1	All	1	
STD-12	...	Washer, plain, tool box fixing bolt.....	6	All	1	
STD-4	...	Nut, tool box stay bolt.....	1	All	3	

NOTE 23.—Does not include the lid fixing screw assembly. That assembly (screw, spring washer and two nuts) is 2s. 1d. extra, making a total of £1 0s. 10d.

### FOOT RESTS.

40-G2M-FR8	...	Rod, footrest, bare.....	1	350	1	10
010913	...	Rod, footrest, bare.....	1	500	1	10
V2-FR6	...	Spacer, footrest rod, between plates.....	1	350	7	
C-FR6	...	Spacer, footrest rod, between plates.....	1	500	1	0
010911	...	Spacer, footrest rod, between arms and plates.....	2	500	6	
010912	...	Washer, plain, footrest rod.....	2	500	2	
STD-194	...	Washer, spring, footrest rod.....	2	350	1	
STD-2	...	Nut, footrest rod.....	2	All	4	
41-G3L-FR22	...	Arm, footrest.....	2	350	11	3
4518	...	Arm, footrest.....	2	500	4	10
16315	...	Pad, rubber, footrest arm.....	2	All	2	3

### PILLION FOOT RESTS.

(These are optional extra equipment.)

011267	...	Pair of pillion footrests, complete (24).....	1	All	10	6
011236	...	Spindle, bare, pillion footrest.....	2	All	3	0
STD-403	...	Bolt, hinge, pillion footrest spindle.....	2	All	6	
STD-73	...	Nut, pillion footrest spindle hinge bolt.....	2	All	3	
16315	...	Pad, rubber, pillion footrest.....	2	All	2	3

NOTE 24.—“Pair of Pillion Footrests, complete,” comprises two spindles with two rubber pads and two hinge bolts and nuts.

### SADDLE.

011065	...	Saddle, with rear springs.....	1	All	2	10	0
38-G3-F60-T	...	Cover, saddle.....	1	All	18	0	
42-G3L-F60-B	...	Spring, saddle, rear.....	2	All	2	3	
41-G3L-F62	...	Bracket, for saddle rear spring.....	2	All	9		
STD-362	...	Bolt, fixing spring to bracket.....	2	All	4		
STD-4	...	Nut, for bolt fixing spring to bracket.....	2	All	3		
STD-368	...	Bolt, fixing bracket to frame.....	2	All	4		
STD-11	...	Washer, plain, bolt fixing bracket to frame.....	2	All	1		
STD-4	...	Nut, bolt fixing bracket to frame.....	2	All	3		
STD-410	...	Bolt, saddle, front hinge.....	1	All	7		
STD-10	...	Washer, plain, saddle hinge bolt.....	1	All	1		
STD-3	...	Nut, saddle hinge bolt.....	1	All	3		

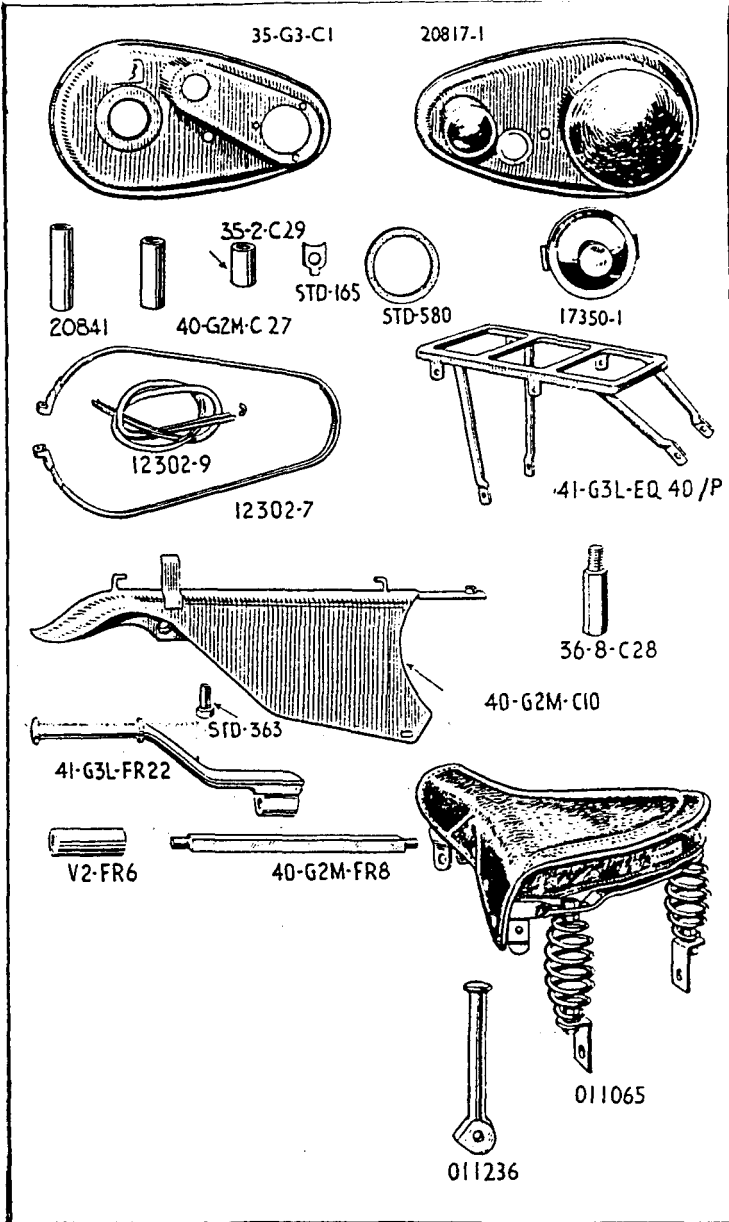

**PILLION SEAT.**

*(This is optional extra equipment.)*

011291...	...	Seat, pillion, with fixing screws, washers and nuts	1	...	All	...	1	7	0
STD-140	...	Screw, fixing pillion seat	4	...	All	...	...	...	3
STD-190	...	Washer, spring, pillion seat screw	4	...	All	...	...	...	1
STD-24	...	Nut, pillion seat fixing screw	4	...	All	...	...	...	3

## NAME TRANSFERS.

38-G3-F391	...	Transfer, for top of tank.....	1	...	All	...	3
38-G3-F392	...	Transfer, for side of tank.....	1	...	All	...	3
38-G3-F393	...	Transfer, for front chaincase.....	1	...	All	...	3
38-G3-F383	...	Transfer, for rear mudguard.....	1	...	All	...	6
38-G3-F385	...	Transfer, for tool box.....	1	...	All	...	4
42-G3L-T57-T	...	Transfer, for petrol tank.....	2	...	All	...	9
STD-9192	...	Transfer, for front forks.....	1	...	All	...	6

The lining on petrol tanks is applied by hand. Therefore transfers for that cannot be supplied.

## CONTROL LEVER AND CABLE SECTION.

### TWIST GRIP.

16-117-CE	...	Twist grip, assembly.....	1	...	All	...	10 6
16-070	...	Grip, rubber, for twist grip.....	1	...	All	...	1 0
16-091	...	Rotor and sleeve, twist grip (25).....	1	...	All	...	5 3
16-060	...	Body, twist grip, top.....	1	...	All	...	4 0
16-061	...	Body, twist grip, bottom.....	1	...	All	...	4 0
11-013	...	Screw, clamping, twist grip body.....	2	...	All	...	3
16-008	...	Spring, friction, twist grip.....	1	...	All	...	9
16-009	...	Screw, twist grip friction spring.....	1	...	All	...	6
16-010	...	Nut, twist grip friction spring screw.....	1	...	All	...	2
16-011	...	Stop, twist grip cable.....	1	...	All	...	6

NOTE 25.—Does not include the rubber grip.

### DUMMY GRIP.

16-069	...	Grip, rubber, dummy.....	1	...	All	...	1 6
--------	-----	--------------------------	---	-----	-----	-----	-----

### CLUTCH CONTROL LEVER.

18-455	...	Lever, assembly, clutch.....	1	...	All	...	9 0
18-519	...	Lever, only, clutch.....	1	...	All	...	5 3
18-234	...	Bracket, clutch lever.....	1	...	All	...	5 3
12-040	...	Clamp, clutch lever bracket.....	1	...	All	...	9
11-014	...	Screw, clutch lever bracket clamp.....	2	...	All	...	3
18-087	...	Pin, fulcrum, clutch lever.....	1	...	All	...	3
18-053	...	Nut, clutch lever fulcrum pin.....	1	...	All	...	3
70-016	...	Washer, lock, clutch lever fulcrum pin nut.....	1	...	All	...	2

### FRONT BRAKE CONTROL LEVER.

This is identical (part numbers and prices) to the CLUTCH CONTROL LEVER, as above.

### EXHAUST LIFTER CONTROL LEVER.

18-454	...	Lever, assembly, exhaust lifter.....	1	...	All	...	9 0
18-059	...	Lever, only, exhaust lifter.....	1	...	All	...	5 3
18-161	...	Bracket, exhaust lifter lever.....	1	...	All	...	5 3
12-040	...	Clamp, exhaust lifter lever bracket.....	1	...	All	...	9
11-014	...	Screw, exhaust lifter lever bracket clamp.....	2	...	All	...	3
11-014	...	Pin, fulcrum, exhaust lifter lever.....	1	...	All	...	3
18-060	...	Nut, exhaust lifter lever fulcrum pin.....	1	...	All	...	3

### AIR CONTROL LEVER.

12-161	...	Lever, assembly, air.....	1	...	All	...	9 0
12-016-B	...	Lever, only, air.....	1	...	All	...	3 9
12-007	...	Bracket, air control lever.....	1	...	All	...	2 9

### IGNITION CONTROL LEVER.

12-171	...	Lever, assembly, ignition.....	1	...	All	...	9 0
12-017-B	...	Lever, only, ignition.....	1	...	All	...	3 9
12-008	...	Bracket, ignition control lever.....	1	...	All	...	2 9

### FITTINGS FOR AIR AND IGNITION CONTROL LEVERS.

12-040	...	Clamp, air or ignition lever bracket.....	2	...	All	...	9
11-014	...	Screw, air or ignition lever bracket clamp.....	4	...	All	...	3
12-029	...	Bolt, central, air or ignition lever.....	2	...	All	...	4
12-031	...	Cap, air or ignition lever.....	2	...	All	...	8
12-033	...	Washer, spring, air or ignition lever.....	2	...	All	...	2

THE COMPLETE CONTROL CABLES LISTED IN THE FOLLOWING SIX PARAGRAPHS INCLUDE ALL THE PARTS THAT MUST BE THREADED ON THE INNER CABLES BEFORE THE NIPPLES ARE FITTED. THEY ARE ASSEMBLED READY FOR USE.

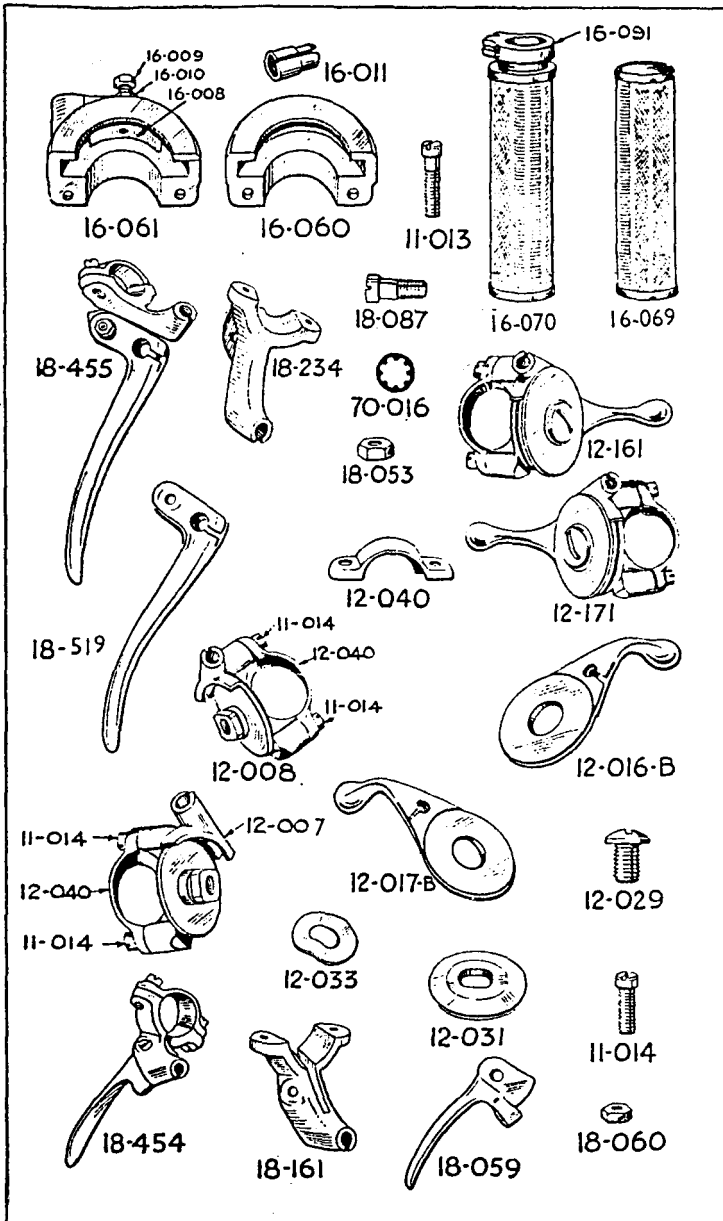

THE INNER WIRES DO NOT INCLUDE THE NIPPLES AND THE OUTER CASINGS DO NOT INCLUDE THE END FERRULES.

**FRONT BRAKE CABLE.**

41-B-2	...	...	Cable, complete, assembled, front brake.....	1	...	All	...	6	4
12-44	...	...	Wire, inner, front brake, finished length 42½ in. }	1	...	All	...	1	1
40-058	...	...	Nipple, brake end, brake inner wire.....	1	...	All	...	1	3
18-088	...	...	Nipple, handlebar end, brake inner wire.....	1	...	All	...	1	3
12C-38½	...	...	Casing, outer, front brake.....	1	...	All	...	1	6

STD-531	...	...	Ferrule, front brake outer casing.....	2	...	All	...	1
16365	...	...	Adjuster, front brake	1	...	All	...	6
16363	...	...	Nut, lock, front brake adjuster.....	1	...	All	...	6
16482	...	...	End, yoke, front brake case.....	1	...	All	...	3
STD-736	...	...	Pin, for yoke end, front brake cable.....	1	...	All	...	4
STD-14	...	...	Pin, split, brake, cable yoke end pin.....	1	...	All	...	1

### CLUTCH CABLE.

41-C-2	...	...	Cable, complete, assembled, clutch.....	1	...	All	...	7 0
12-52	...	...	Wire, inner, clutch, finished length 50½ in.....	1	...	All	...	1 1
4	...	...	Nipple, gear box end, clutch inner wire.....	1	...	All	...	1 1
18-088	...	...	Nipple, handlebar, end clutch inner wire.....	1	...	All	...	3
12C-47	...	...	Casing, outer, clutch.....	1	...	All	...	3 0
STD-531	...	...	Ferrule, clutch outer casing.....	2	...	All	...	1
20876	...	...	Adjuster, clutch cable.....	1	...	All	...	7
STD-612	...	...	Nut, lock, clutch cable adjuster.....	1	...	All	...	6

### VALVE LIFTER CABLE.

41-V-2	...	...	Cable, complete, assembled, exhaust lifter.....	1	...	All	...	5 3
12-35	...	...	Wire, inner, exhaust lifter, finished length 33½ in.....	1	...	All	...	10
40-058	...	...	Nipple, engine end, exhaust lifter inner wire.....	1	...	All	...	3
40-058	...	...	Nipple, handlebar end, exhaust lifter inner wire.....	1	...	All	...	3
12C-30½	...	...	Casing, outer, exhaust lifter.....	1	...	All	...	2 1
STD-531	...	...	Ferrule, exhaust lifter outer casing.....	2	...	All	...	1
STD-709	...	...	Armouring, exhaust lifter outer casing.....	1	...	All	...	4
11751	...	...	Adjuster, exhaust lifter cable.....	1	...	All	...	3
STD-622	...	...	Nut, lock, exhaust lifter cable adjuster.....	1	...	All	...	3

### IGNITION CONTROL CABLE.

39-1-1	...	...	Cable, complete, assembled, ignition.....	1	...	All	...	6 0
11-45	...	...	Wire, inner, ignition, finished length 42½ in.....	1	...	All	...	1 0
MC-4	...	...	Nipple, magneto end, ignition inner wire.....	1	...	All	...	6
12-034	...	...	Nipple, handlebar end, ignition inner wire.....	1	...	All	...	2
11C-39½	...	...	Casing, outer ignition.....	1	...	All	...	2 6
STD-528	...	...	Ferrule, ignition outer casing.....	2	...	All	...	1
MC-9	...	...	Cap, rubber, cable entry to magneto.....	1	...	All	...	3
MC-7	...	...	Adjuster, ignition cable.....	1	...	All	...	3
MC-8	...	...	Nut, lock, ignition cable adjuster.....	1	...	All	...	2
MC-6	...	...	Sleeve, ignition cable, screws into magneto.....	1	...	All	...	6
454969	...	...	Plunger, ignition cable.....	1	...	All	...	6
M3550-2	...	...	Washer, lock, ignition cable sleeve.....	1	...	All	...	2
MC-5	...	...	Spring, return, ignition cable.....	1	...	All	...	2

### THROTTLE CONTROL CABLE.

41-T-2	...	...	Cable, complete, assembled, throttle.....	1	...	350	...	4 10
45-T-2	...	...	Cable, complete, assembled, throttle.....	1	...	500	...	4 10
SW2-41	...	...	Wire, inner, throttle, finished length 39½ in.....	1	...	350	...	1 0
SW2-41½	...	...	Wire, inner, throttle, finished length 40½ in.....	1	...	500	...	1 0
1482	...	...	Nipple, carburettor end, throttle inner wire.....	1	...	All	...	2
12-034	...	...	Nipple, handlebar end, throttle inner wire.....	1	...	All	...	2
11C-39	...	...	Casing, outer, throttle.....	1	...	All	...	2 3
STD-528	...	...	Ferrule, throttle outer casing.....	2	...	All	...	1

### AIR CONTROL CABLE.

41-A-1	...	...	Cable, complete, assembled, air.....	1	...	350	...	4 10
45-A-1	...	...	Cable, complete, assembled, air.....	1	...	500	...	4 10
11-38	...	...	Wire, inner, air, finished length 37 in.....	1	...	350	...	1 0
11-38½	...	...	Wire, inner, air, finished length 37½ in.....	1	...	500	...	1 0
1482	...	...	Nipple, carburettor end, air inner wire.....	1	...	All	...	2
12-034	...	...	Nipple, handlebar end, air inner wire.....	1	...	All	...	2
11C-32	...	...	Casing, outer, air.....	1	...	All	...	1 10
STD-528	...	...	Ferrule, air outer casing.....	2	...	All	...	1

## TANK SECTION.

### PETROL TANK.

010894	...	...	Tank, petrol bare.....	1	...	All	...	7 0 0
38-G3-T15-A	...	...	Bolt, fixing tank (26).....	3	...	All	...	9
39-G3-T15	...	...	Bolt, fixing tank (Hexagon head) (27).....	1	...	All	...	9
16413	...	...	Pad, rubber, thick, tank fixing bolt (28).....	4	...	All	...	3
16414	...	...	Pad, rubber, thin, tank fixing bolt (29).....	3	...	All	...	3
STD-173	...	...	Washer, metal, plain, tank fixing bolt (30).....	5	...	350	...	3
STD-173	...	...	Washer, metal, plain, tank fixing bolt (31).....	9	...	500	...	3
41-G3L-T97	...	...	Wire, copper, 5 ft. by 20 S.W.G.....	1	...	All	...	3



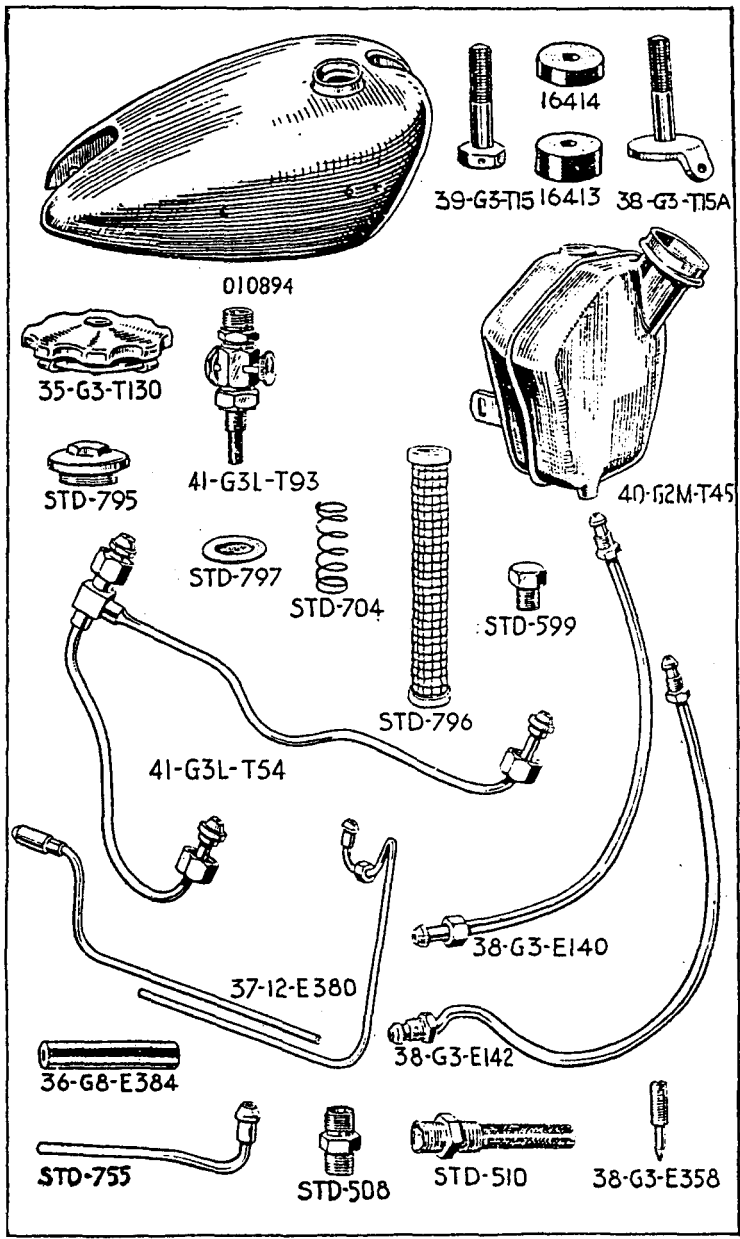

NOTE 26.—Used in all locations except the rear location on left hand side.

NOTE 27.—Only used in the rear location on left hand side.

NOTE 28.—One used on each of the four tank fixing bolts.

NOTE 29.—Used in all locations except the rear location on left hand side.

NOTE 30.—One only used in all locations except the rear location on left hand side.

Two used in the rear location on left hand side.

NOTE 31.—Two used, superimposed, in all locations except in the rear location on left hand side.

Three used in the rear location on left hand side. (All superimposed between tank and supporting bracket).

## PETROL TANK FITTINGS.

35-G3-T130	...	...	Cap, filler, for petrol tank.....	1	...	All	...	4	6
A-T30-C	...	...	Washer, only, for petrol tank filler cap.....	1	...	All	...	4	4
41-G3L-T93	...	...	Tap, for petrol feed, with filter.....	2	...	All	...	4	6
STD-200	...	...	Washer, fibre, for petrol feed tap.....	2	...	All	...	3	3
38-G3-T4-L	...	...	Grip, knee, left hand side.....	1	...	All	...	3	9
38-G3-T4-R	...	...	Grip, knee, right hand side.....	1	...	All	...	3	9
38-G3-T34-L	...	...	Plate, for left hand knee grip.....	1	...	All	...	9	9
38-G3-T34-R	...	...	Plate, for right hand knee grip.....	1	...	All	...	9	9
STD-70	...	...	Bolt, fixing knee grip plate.....	4	...	All	...	3	3
STD-12	...	...	Washer, plain, knee grip plate bolt.....	4	...	All	...	1	1
STD-639	...	...	Spacer, knee grip plate bolt.....	4	...	All	...	3	3

## OIL TANK.

40-G2M-T45	...	...	Tank, oil, bare.....	1	...	All	...	13	9
35-G3-T130	...	...	Cap, filler, oil tank.....	1	...	All	...	4	6
A-T30-C	...	...	Washer, only, for oil tank filler cap.....	1	...	All	...	4	4
STD-599	...	...	Plug, drain, for oil tank.....	1	...	All	...	4	4
STD-200	...	...	Washer, fibre, oil tank drain plug.....	1	...	All	...	3	3
STD-796	...	...	Filter, felt, for oil tank.....	1	...	All	...	3	9
STD-704	...	...	Spring, for oil tank felt filter.....	1	...	All	...	6	6
STD-797	...	...	Cap, metal, dished, for oil tank felt filter.....	1	...	All	...	4	4
STD-795	...	...	Cap, screwed, oil tank filter compartment.....	1	...	All	...	2	3
STD-583	...	...	Washer, cork, filter compartment cap.....	1	...	All	...	3	3

For the two nuts and washers that retain the oil tank (and the Battery carrier) to the main frame, see BATTERY CARRIER

For the bolt, two spacers, washer and nut, fixing the oil tank bracket to the rear mudguard, see REAR MUDGUARD

## PETROL PIPES.

41-G3L-T54	...	...	Pipe, assembly, petrol feed (32).....	1	...	350	...	8	3
011161...	...	...	Pipe, assembly, petrol feed (32).....	1	...	500	...	8	3

## OIL PIPES.

38-G3-E140	...	...	Pipe, oil feed, assembly (32).....	1	...	All	...	5	3
38-G3-E142	...	...	Pipe, oil return, assembly (32).....	1	...	All	...	5	3
37-12-E380-T	...	...	Pipe, rocker box oil feed, top half with union nut	1	...	All	...	2	4
37-12-E380-B	...	...	Pipe, rocker box oil feed, bottom half with union nut	1	...	All	...	3	4
STD-755	...	...	Pipe, oil discharge, for release valve.....	1	...	All	...	1	6

NOTE 32.—The "nipples" on these pipes are formed integrally with the piping. Therefore union nuts cannot be removed or re-fitted.

## OIL PIPE FITTINGS.

36-G8-E384	...	...	Connection, rubber, rocker oil feed pipe.....	1	...	All	...	9	9
STD-508	...	...	Union, oil, in rocker box.....	1	...	All	...	6	6
STD-510	...	...	Union, with filter, oil, feed from tank.....	1	...	All	...	2	0
STD-504-N	...	...	Nut, union, top end rocker feed pipe.....	1	...	All	...	6	6
37-12-E385	...	...	Nut, union, bottom end rocker feed pipe.....	1	...	All	...	1	6
STD-504-N	...	...	Nut, union, oil discharge pipe.....	1	...	All	...	6	6
38-G3-E358	...	...	Screw, needle adjusting, valve feed (33).....	1	...	All	...	7	7
STD-290	...	...	Nut, lock, needle adjusting screw.....	1	...	All	...	3	3

NOTE 33.—This screws into the right-hand side of the cylinder head and regulates the oil feed to the inlet valve guide.

## WHEEL AND BRAKE SECTION.

PART NUMBER.	DESCRIPTION.	QTY.	USED ON.	PRICE EACH £ s. d.
<b>TYRES.</b>				
011088...	Cover, only, 26 in. by 3-25 in.....	2	All	1 19 5
011089...	Tube, inner, only, 26 in. by 3-25 in.....	2	All	9 1
011090...	Tape, for 19 in. by 2½ in. rim (26 in. by 3-25 in. tyres) .....	2	All	1 0
41-G3-H132	Bolt, security, for rear wheel tyre .....	1	All	3 3
<b>FRONT WHEEL.</b>				
41-G3L-H45-A	Wheel, front, assembly, with all fittings (34).....	1	All	6 18 6
41-G3L-H45	Wheel, front, bare, less all fittings.....	1	All	3 4 6
41-G3L-H20	Rim, front, 19 in. by 2½ in.....	1	All	17 3
41-G3L-H51	Spoke, front, left, 5 ½ in. by 8G by 10G.....	20	All	3
12399	Spoke, front, right, 8 ½ in. by 9G by 11G.....	20	All	3
20678	Nipple, front, left, -225 in. by 10G.....	20	All	1
20680	Nipple, front, right, -225 in. by 11G.....	20	All	1
40-G2M-H19	Hub, front wheel, shell only, with brake drum.....	1	All	2 5 0
STD-51	Nipple, grease, for front wheel hub.....	1	All	3
NOTE 34.—" Wheel, front, assembly, with all fittings " comprises : Rim, spokes, nipples, hub, all bearings and all brake parts including cover plate and expander lever, but does not include the tyre.				
<b>FRONT WHEEL BEARINGS.</b>				
40-G12M-H10...	Spindle, with roller bearings, front wheel.....	1	All	1 4 0
11909	Washer, felt, for hub bearings.....	2	All	3
11910	Ring, spring, locating bearings in hub shell.....	1	All	3
11911	Cup, for hub bearing felt washer.....	1	All	4
11912	Ring, spacing, for hub bearing felt washer.....	1	All	3
11913	Ring, retaining felt washer.....	3	All	3
11914	Nut, lock, hub bearing adjusting ring.....	1	All	1 10
11915	Ring, adjusting, for hub bearing.....	1	All	2 3
40-G12M-H47	Nut, locating front brake cover plate.....	1	All	4
40-G12M-B100	Washer, locating front brake cover plate.....	1	All	6
40-G12M-H46	Nut, outside, securing front brake cover plate.....	1	All	1 1
STD-1	Nut, front wheel spindle, left side.....	1	All	4
STD-8	Washer, plain, front wheel spindle, left side.....	1	All	1
<b>REAR WHEEL.</b>				
41-G3L-H31-A	Wheel, rear, assembly, with all fittings (35).....	1	All	5 10 9
41-G3L-H31	Wheel, rear, bare, less all fittings.....	1	All	3 15 9
41-G3L-H21	Rim, rear, 19 in. by 2½ in.....	1	All	17 3
39-B-H54	Spoke, rear, left or right, 8 ½ in. by 6G by 9G.....	40	All	3
12344	Nipple, rear, left or right, -250 in. by 9G.....	40	All	.1
41-G3L-H2	Hub, rear wheel, shell only.....	1	All	2 1 6
STD-51	Nipple, grease, for rear wheel hub.....	1	All	3
NOTE 35.—" Wheel, rear, assembly, with all fittings " comprises : Rim, spokes, nipples, hub, all bearings, but does not include the centre solid spindle, washers, spacers, nuts, brake parts, sprocket and brake drum, speedometer drive and tyre.				
<b>REAR WHEEL BEARINGS.</b>				
11905	Spindle, hollow, with roller bearings, rear wheel	1	All	1 6 3
11909	Washer, felt, for hub bearings .....	2	All	3
11910	Ring, spring, locating bearings in hub shell.....	1	All	3
11911	Cup, for hub bearing felt washer.....	1	All	4
11912	Ring, spacing, for hub bearing felt washer.....	1	All	3
11913	Ring, retaining felt washer.....	3	All	3
11914	Nut, lock, hub bearing adjusting ring .....	1	All	1 10
11915	Ring, adjusting, for hub bearing.....	1	All	2 3
41-G3L-H4-A	Spindle, centre, solid, for rear wheel.....	1	All	3 9
41-G3L-H106	Spacer, rear solid spindle (next to cover plate)....	1	All	4
41-G3L-854	Spacer, rear solid spindle (fits in fork end).....	1	All	7
41-G3L-H26-S	Spacer, rear solid spindle (for speedometer gear box).....	1	All	4
STD-2	Nut, rear solid spindle .....	2	All	4
STD-9	Washer, plain, rear solid spindle.....	2	All	1

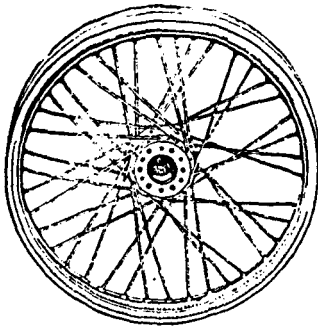

41-G3L-H31

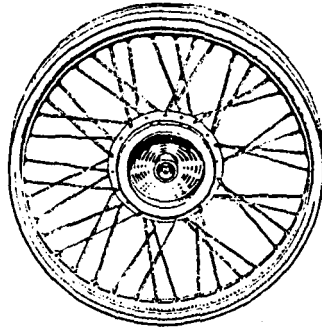

41-G3L-H45



41-G3L-B54



41-G3L-H106



41-G3L-H4-A



11909



11911



11912



11913



41-G3L-H265



11910



11915



11914

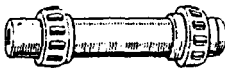

11905



40-G12M-H47



40-G12M-H10

PART NUMBER.	DESCRIPTION.	QTY.	USED ON.	PRICE EACH £ s. d.
--------------	--------------	------	----------	-----------------------

### FRONT BRAKE.

40-G2M-B115	Drum, front brake, bare	1	All	15 9
STD-140	Screw, fixing front brake drum to hub shell	8	All	3
40-G12M-B60	Plate, cover, front brake	1	All	18 0
40-G12M-B7-F	Bolt, anchor, front brake cover plate	1	All	1 3
STD-11	Washer, plain, front brake anchor bolt	1	All	1
STD-4	Nut, front brake anchor bolt	1	All	3
STD-14	Pin, split, front brake anchor bolt	1	All	1
41-12-B71-ASS	Shoes, pair of, for front brake, with brake linings and thrust collars—only supplied in pairs—per pair	1	All	14 0
41-8-B73	Collar, thrust, brake expander adjusting	2	All	1 6
3836-3	Linings, brake, per pair of, less rivets	1	All	3 4
STD-105	Rivets, for brake linings, per set of	16	All	4
20508	Spring, for brake shoes	2	All	3 3
36-12-B51	Expander, for brake shoes	1	All	3 9
40-G12M-B65	Lever, for front brake shoe expander	1	All	4 10
STD-51	Nipple, grease, for brake shoe expander	1	All	3
STD-174	Washer, plain, for brake shoe expander	1	All	1
STD-4	Nut, for brake shoe expander	1	All	3

### REAR BRAKE.

41-G3L-B20	Plate, cover, rear brake	1	All	19 6
37-8-By	Bolt, anchor, rear brake cover plate	1	All	7
STD-3	Nut (thick), rear brake anchor bolt	1	All	3
STD-73	Nut, lock (thin) rear brake anchor bolt	1	All	3
STD-6	Pin, split, rear brake anchor bolt	1	All	1
41-12-B71-ASS	Shoes, pair of, for rear brake, with brake linings and thrust collars—only supplied in pairs—per pair	1	All	14 0
41-8-B73	Collar, thrust, brake expander adjusting	2	All	1 6
3836-3	Linings, brake, per pair of, less rivets	1	All	3 4
STD-105	Rivets, for brake linings, per set of	16	All	4
20408	Spring, for brake shoes	2	All	3
36-12-B51	Expander, for brake shoes	1	All	3 9
38-12-B30	Lever, for rear brake shoe expander	1	All	3 9
STD-51	Nipple, grease, for brake shoe expander	1	All	3
STD-174	Washer, plain, for brake shoe expander	1	All	1
STD-4	Nut, for brake shoe expander	1	All	3

### REAR BRAKE OPERATING PARTS.

37-G3-B1	Pedal, rear, foot brake	1	All	11 7
37-G3-B3	Bush, rear brake foot pedal	1	All	9
STD-54	Nipple, grease, rear brake foot pedal	1	All	9
37-G3-B2	Spindle, rear brake foot pedal	1	All	1 1
STD-9	Washer, plain, rear brake pedal spindle	2	All	1
STD-194	Washer, spring, rear brake pedal spindle	1	All	1
STD-2	Nut, rear brake pedal spindle	1	All	4
37-G3-B8	Spring, return, rear brake foot pedal	1	All	9
STD-345	Bolt, adjusting, rear brake foot pedal	1	All	4
STD-5	Nut, lock, rear brake foot pedal adjusting bolt	1	All	3
37-G3C-B5	Rod, bare, rear brake	1	All	4 6
STD-735	End, yoke, front end of rear brake rod	1	All	1 3
STD-736	Pin, rear brake rod yoke end	1	All	4
STD-14	Pin, split, brake rod yoke end pin	1	All	1
36-G3-B18	Spring, rear brake rod	1	All	4
STD-178	Washer, plain, rear brake rod spring	1	All	1
11772	Clip, adjusting, rear end of rear brake rod	1	All	2 3
STD-736	Pin, rear brake rod adjusting clip	1	All	4
STD-14	Pin, split, brake rod adjusting clip pin	1	All	1
STD-615	Nut, knurled, adjusting, rear brake rod	1	All	2 7

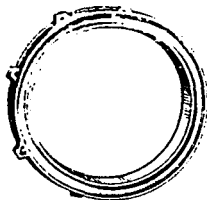

40-G2M-B115

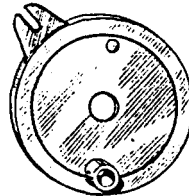

40-G12M-B60

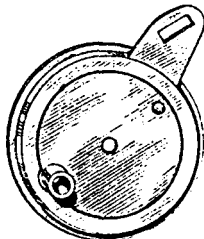

41-G3L-B20

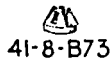

41-8-B73



41-12-B71-ASS



40-G12M-B7F

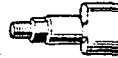

36-12-B51



20408



STD-51



40-G12M-B65



38-12-B30

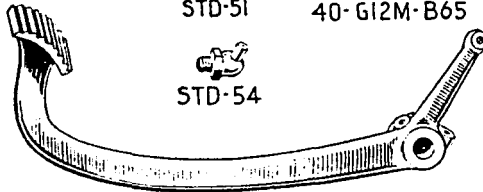

37-G3-B1



STD-54

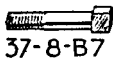

37-8-B7

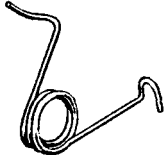

37-G3-B8

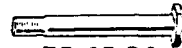

37-G3-B2



37-G3-B3

37-G3C-B5



STD  
736

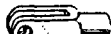

STD-735



36-G3-B18



11772



STD-615

## ELECTRICAL SECTION.

PART NUMBER.	DESCRIPTION.	QTY.	USED ON.	PRICE, EACH £ s. d.
<b>MAGNETO.</b>				
42020-B	Magneto, type NI-3-A0.....	1	All	5 15 6
463066...	Pick-up, with brush and spring.....	1	All	3 6
460061...	Cover, contact breaker.....	1	All	1 0
MLCB-1	Contact breaker, complete.....	1	All	11 6
484098...	Set of points, for contact breaker.....	1	All	4 6
M-2687-1	Tappet, for contact breaker.....	1	All	1 3

### MAGNETO FIXING PARTS.

37-G3-E76	Platform, for magneto (36).....	1	350	6 9
39-G9-E76	Platform, for magneto (36).....	1	500	6 9
STD-341	Bolt, fixing magneto, right, long.....	2	All	4
STD-340	Bolt, fixing magneto, left, short.....	2	All	4
STD-12	Washer, plain, magneto fixing bolt.....	4	All	1
STD-4	Nut, platform front fixing bolt, left side.....	1	All	3
35-G3-E56	Nut, platform front fixing bolt, right side.....	1	All	1 1
STD-11	Washer, plain, platform front fixing bolt.....	2	All	1

NOTE 36.—The magneto platform is mounted above the engine rear plates. Its rear end is secured by the bolt on the seat tube bottom lug and the forward end is secured by the dynamo strap square crossbar which is threaded on both ends and the nuts and washers listed in the final three lines above fit on that bar.

### DYNAMO.

200430...	Dynamo, type E3AR-A05-1.....	1	All	3 15 0
200290...	Set of brushes, for dynamo.....	1	All	2 6

### DYNAMO FIXING PARTS.

35-G3-E275	Strip, dynamo, locating.....	1	350	1 1
39-G9-E275	Strip, dynamo, locating.....	1	500	1 1
STD-44	Screw, fixing, locating strip to dynamo.....	2	All	3
STD-178	Washer, plain, locating strip screw.....	2	All	1
F-E76	Strap, clamping dynamo.....	1	All	2 3
STD-791	Pin, hinge, dynamo clamping strap.....	1	500	6
39-G9-E282	Pin, hinge, dynamo clamping strap.....	1	500	6
35-G3-E277	Sleeve, threaded, eye of dynamo strap.....	1	All	7
41-G3L-E280	Bolt, tightening, dynamo strap.....	1	All	1 0
35-G3-E279	Crossbar, square, dynamo clamping strap.....	1	350	1 1
39-G9-E279	Crossbar, square, dynamo clamping strap.....	1	500	1 1

### VOLTAGE REGULATOR.

33020-A	Regulator, complete Unit, Type MCRI-L31.....	1	All	1 12 5
STD-70	Bolt, fixing regulator to frame.....	2	All	3
STD-12	Washer, plain, regulator fixing bolt.....	2	All	1
STD-5	Nut, regulator fixing bolt.....	2	All	3

### BATTERY.

PUW-7E	Battery, with lid, dry and uncharged (37).....	1	All	1 4 0
PUW-7E (C)	Battery, with lid, filled and charged (38).....	1	All	1 6 3
S-2171	Lid, only, for battery.....	1	All	1 6

NOTE 37.—This is a battery that has not been filled with electrolyte (acid) and is, of course, not charged. It requires no special packing and can safely be packed with other goods.

NOTE 38.—Filled with electrolyte and charged ready for use. Is only supplied to callers. In NO CIRCUMSTANCES do we pack and despatch this battery.

PART NUMBER.	DESCRIPTION.	QTY.	USED ON.	PRICE EACH £ s. d.
--------------	--------------	------	----------	-----------------------

### HEAD LAMP.

50128-A	Lamp, head, complete (39).....	1	All	3 10 0
LR432	Rim, bare, for head lamp.....	1	All	8 3
516144	Glass, only, for head lamp.....	1	All	2 0
516145	Reflector, only (40).....	1	All	9 0
515191	Back shell, with bulb holders.....	1	All	6 0

NOTE 39.—"Lamp, head, complete," comprises complete lamp with ammeter, switch bulbs, handlebar dipping switch and complete cable harness.

NOTE 40.—Does not include the "Back shell, with bulb holders."

### HEAD LAMP STAYS.

41-G3L-FF73-7	Stay, head lamp, bottom, left.....	1	All	9
41-G3L-FF73-R	Stay, head lamp, bottom, right.....	1	All	9
41-G3L-FF74-L	Stay, head lamp, top, left.....	1	All	9
41-G3L-FF74-R	Stay, head lamp, top, right.....	1	All	9

The head lamp top stays are secured by the speedometer bracket fixing bolts and the bottom stays are secured by the fork crown pinch bolts. These bolts are all listed on page 25.

### REAR LAMP.

53037-A	Lamp, rear, type WT-203, complete.....	1	All	10 6
571417	Body, assembly, rear lamp, with red glass.....	1	All	2 3
STD-744-S	Screw, fixing rear lamp to number plate.....	2	All	3
STD-744-N	Nut, rear lamp fixing screw.....	2	All	3

### HORN.

HF-128-A-M	Horn, electric.....	1	All	1 7 6
STD-402	Bolt, fixing horn to engine plate.....	1	All	6
STD-10	Washer, plain, horn fixing bolt.....	1	All	1
STD-3	Nut, horn fixing bolt.....	1	All	3

### ELECTRICAL SUNDRIES.

364455	Ammeter, for head lamp panel.....	1	All	9 0
351551	Switch, main lighting, for head lamp panel.....	1	All	8 6
380057	Switch, dipping, for handlebar.....	1	All	4 3
762178	Switch, horn, for handlebar.....	1	All	4 6
351567	Handle, with screw, for main lighting switch.....	1	All	1 6
990501	Cable harness, main lighting (41).....	1	All	8 0
851884	Cable harness, triple for dipping switch.....	1	All	1 6
STD-543	Cable, high tension, for sparking plug, per foot.....	1	All	9
STD-541	Terminal, for high tension cable.....	1	All	3
STD-542	Terminal, for low tension earth wires.....	2	All	2
SA-147	Connector, screwed, for rear lamp cable and battery.....	2	All	9
70	Bulb, head lamp, main, 6 volt, 24 by 24 watts.....	1	All	2 9
200	Bulb, head lamp, pilot, 6 volt, 3 watts.....	1	All	1 3
200	Bulb, rear lamp, 6 volt, 3 watts.....	1	All	1 3
L-10	Plug, sparking, Champion type L-10.....	1	350	5 0
H-14	Plug, sparking, Lodge type H-14.....	1	500	6 0
STD-524-A	Clip, cable, pliable strip, 7 in. long.....	10	All	3
STD-525	Clip, cable, pliable strip, 3½ in. long.....	5	All	2

NOTE 41.—Does not include the triple wire from head lamp to handlebar dipping switch.



## ACCESSORY SECTION.

PART NUMBER.	DESCRIPTION.	QTY.	USED ON.	PRICE EACH £ s. d.
<b>SPEEDOMETER.</b>				
S-433-1-L	Head, only, speedometer, trip, 80 M.P.H.	1	All	2 7 6
S-433-5-L	Head, only, speedometer, trip, 140 K.P.H.	1	All	2 7 6
53279-1	Set of bulb holding parts, for head (42)	1	All	3 4
53205	Bulb, 6 volts, 1-8 watts, M.B.C. for head	1	All	1 5
N-1253	Nut, fixing speedometer head to bracket	2	All	2
W-7216	Washer, spring, speedometer bracket nut	2	All	1
53395-1-54	Cable, speedometer drive, complete	1	All	17 6
52108-54	Cable, speedometer drive, inner only	1	All	8 9
53398-1-54	Cable, speedometer drive, outer only	1	All	8 2
41-G3L-F311	Clip, for speedometer drive cable	1	All	2
STD-450	Screw, fixing drive cable clip	1	All	1
STD-190	Washer, spring, drive cable clip screw	1	All	1
52283-2	Gear box, speedometer, complete	1	All	1 12 6
40-G12M-FF78	Bracket, for speedometer head	1	All	9
STD-342	Bolt, fixing speedometer bracket to forks	2	All	3
STD-12	Washer, plain, speedometer bracket bolt	2	All	1
011201	Speedometer, trip, 80 M.P.H., complete	1	All	3 10 0
011203	Speedometer, trip, 140 K.P.H., complete	1	All	3 10 0
011204	Speedometer, trip, 180 K.P.H., complete	1	All	1 10 0

NOTE 42.—Only sold in complete sets and includes the bulb.

### TOOLS.

17520	Bag, for tools	1	All	1 9
L-TK13	Screwdriver	1	All	6
L-TK15	Pliers, sidecutting	1	All	5
11074	Pliers, for engine pin rivets	1	All	5
L-TK20	Gun, grease	1	All	5
38-G3-EQ2	Inflator, tyre	1	All	5 6
40-G3-TK29	Lever, tyre	1	All	1 6
41-G3L-TK1	Spanner, double end, $\frac{3}{8}$ in. by $\frac{1}{2}$ in.	2	All	2 3
41-G3L-TK2	Spanner, double end, $\frac{3}{8}$ in. by $\frac{3}{4}$ in.	1	All	3 4
R-TK3	Spanner, triple end, $\frac{3}{8}$ in. by 1-011 in. by 1-2 in.	1	All	1 6
17634	Spanner, box, with continuity, $\frac{3}{8}$ in. by 1-2 in.	1	All	1 6
R-TK1	Spanner, single end, dynamo chain adjustment	1	All	9
11914-S	Spanner, hook, for hub bearing lock nut	1	All	1 0
L-TK5	Spanner, double end, with gauge, contacts	1	All	9
L-TK12	Wrench, adjustable	1	All	5

### PANNIER BAGS.

41-G3L-EQ7-ASS	Bags, pannier, complete set of two with all necessary fittings, including rear carrier which is essential, £6 6s. 11d. plus 13s.-4d. purchase tax	1	All	1 11 8
41-G3L-EQ7-L	Bag, pannier (with plain strap), £1 5s. plus 6s. 8d. purchase tax	1	All	3 9
41-G3L-EQ7-R	Bag, pannier (with slide strap), £1 5s. plus 6s. 8d. purchase tax	1	All	3 9
41-G3L-EQ7-S-S	Strap, short, with buckle	1	All	19 9
41-G3L-EQ7-S-L	Strap, long, plain	1	All	6
41-G3L-EQ26	Frame, carrying pannier bag	2	All	6
41-G3L-F250-L	Bracket, long, for bottom of left frame	1	All	6
41-G3L-F250-R	Bracket, short, for bottom of right frame	1	All	1 0
41-G3L-F423	Stay, connecting pannier frames at bottom	1	All	3
STD-343	Bolt, fixing pannier frame to rear carrier	4	All	3
STD-633	Spacer, for pannier frame fixing bolt	4	All	3
STD-12	Washer, plain, for pannier frame fixing bolt	4	All	3
STD-70	Bolt, for pannier frame brackets	8	All	1
STD-191	Washer, spring, for frame bracket bolt	4	All	3
STD-5	Nut, for pannier frame and bracket bolts	12	All	3





