Norton

Model Coverage

Model Years 1966-1976

Atlas
G15CS
N15CS
P-11
Commando 750
Commando 850

Index

GENERAL SPECIFICATIONS	Clutch and Primary Drive
MAINTENANCE	Timing Case
Lubrication	Bottom End
Engine	Transmission
Gearbox	Engine and Transmission Specifications
Primary Chaincase	Torque Specifications
Front Forks	LUBRICATION SYSTEM
Drive Chain	Oil Pump
Grease Nipples	System Components
Contact Breaker Points	Checking the Lubrication System
Speedometer and Tachometer Cables	Oil Pump Specifications
Steering Head Bearings	FUEL SYSTEMS
Rear Shock Absorbers	Monobloc
Wheel Bearings	Concentric
Service Checks and Adjustments	Carburetor Specifications
Clutch	ELECTRICAL SYSTEM
Brake Adjustment	Ignition System
Primary Drive Chain	Magneto
Final Drive Chain	Capacitor Ignition
Cam Chain	Charging System
Air Cleaner	System Components
Periodic Maintenance Intervals	Starter Motor
Maintenance Data	Wiring Diagrams
Recommended Lubricants	CHASSIS
TUNE-UP	Wheels
Valve Adjustment	Disc Brake Service
Contact Breaker Points	Front Forks
Ignition Timing	Steering Head
Carburetor Adjustments	Rear Shock Absorbers
Tune-Up Specifications	Swing Arm
ENGINE AND TRANSMISSION	Frame
Engine Removal and Installation	Chassis Specifications
Top End	

Norton

General Specifications

	Commando 650	Commando 750 (Standard)	Commando 750 (Combat)	Atlas	GISSCS N15CS	F-11
DIMENSIONS						
Net Weight (lbs)	422-436	390	390	410	N.A.	N.A.
Ground Clearance (in.)	6	6	6	6	N.A.	N.A.
Wheelbase (in.)	57	50 $\frac{1}{2}$	50 $\frac{1}{2}$	N.A.	N.A.	N.A.
Overall Length (in.)	86	87 $\frac{1}{2}$	87 $\frac{1}{2}$	N.A.	N.A.	N.A.
Overall Width (in.)	26	26	26	26	26	26
Seat Height (in.)	31	31	31	N.A.	N.A.	N.A.
ENGINE						
Displacement (cc)	828	745	745	745	745	745
Bore x Stroke (mm)	77 x 89	73 x 89	73 x 89	73 x 89	73 x 89	73 x 89
Compression Ratio	8.5 : 1	8.9 : 1	10 : 1	7.5 : 1	7.5 : 1	7.5 : 1
Carburetor (Amal)	932	930	932	389 Monobloc or 930	389 Monobloc	930
Ignition	Battery and coil	Battery and coil	Battery and coil	Magneto	Magneto	Battery and coil
TRANSMISSION						
Clutch Type	Diaphragm, multi-plate	Diaphragm, multi-plate	Diaphragm, multi-plate	Dry-type, multi-plate	Dry-type, multi-plate	Dry-type, multi-plate
Gear Ratios (: 1)						
First	11.20	12.40	12.4	11.6	12.05	12.65
Second	7.45	8.25	8.25	7.70	8.40	8.40
Third	5.30	5.90	5.90	5.52	6.03	6.03
Fourth	4.38	4.84	4.84	4.53	4.98	4.98
CHAINS						
Rear (in.)	$\frac{3}{8}$ x $\frac{3}{8}$ (99 pitches)	$\frac{3}{8}$ x $\frac{3}{8}$ (98 pitches)	$\frac{3}{8}$ x $\frac{3}{8}$ (98 pitches)	$\frac{3}{8}$ x $\frac{1}{4}$ (97 pitches)	$\frac{3}{8}$ x 0.380 (97 pitches)	$\frac{3}{8}$ x 0.380 (97 pitches)
Primary (in.)	$\frac{3}{8}$ (triple row) (92 pitches)	$\frac{3}{8}$ (triple row) (92 pitches)	$\frac{3}{8}$ (triple row) (92 pitches)	$\frac{1}{2}$ x 0.305 (76 pitches)	$\frac{1}{2}$ x 0.305 (76 pitches)	$\frac{1}{2}$ x 0.305 (76 pitches)
Camschaft (in.)	$\frac{3}{8}$ x 0.225 (38 pitches)	$\frac{3}{8}$ x 0.225 (38 pitches)	$\frac{3}{8}$ x 0.225 (38 pitches)	$\frac{3}{8}$ x 0.225 (38 pitches)	$\frac{3}{8}$ x 0.225 (38 pitches)	$\frac{3}{8}$ x 0.225 (38 pitches)
Magneto (in.)				$\frac{3}{8}$ x $\frac{1}{2}$ (42 pitches)	$\frac{3}{8}$ x $\frac{1}{2}$ (42 pitches)	
CHASSIS						
Front Suspension						
Rear Suspension						
Tire Size						
Front	4.10 x 19	4.10 x 19	4.10 x 19	3.25 x 19	3.25 x 19	3.25 x 19
Rear	4.10 x 19	4.10 x 19	4.10 x 19	4.00 x 18	4.00 x 18	4.00 x 18
ELECTRICAL						
System Voltage	12	12	12	12	12	12
Generator				Alternator on all		

N.A. Not available

Maintenance

NOTE: Common maintenance procedures are explained in detail in "General Information."

Lubrication

ENGINE

Oil should be changed every 2500 miles under normal operating conditions. Change oil when engine is warm.

Use SAE 20/50 or SAE 30 "SE" if the average temperature is above 32° F., and SAE 10/30 or SAE 20 "SE" oil if below this.

Checking Oil Level

1. Remove the seat, if necessary (as on Commandos) to gain access to the oil tank cap. Remove the cap.

2. Start the engine and let it run for a few moments until the sump has been scavenged and the oil in the tank is at its normal level as in operation. You can tell when the sump has been emptied, as the

oil flow coming from the return line inside the oil tank will become intermittent and splutter somewhat.

3. Check the oil level. On Commando models, a dipstick is provided. The oil level should not exceed the "H" mark, or fall below the "L" mark.

Early Commando machines have an oil level tube adjacent to the oil tank. The oil level should be about half-way up the tube under operating conditions.

On all other models, gauge the oil level against the decal level lines on the side of the tank. Both maximum and minimum levels are marked.

Putting too much oil in will cause it to spill out of the overflow tube while in operation, while too little will cause an excess of heat to be built up in the remaining oil.

Changing Oil

1. Let the engine run until it is warm, then remove the seat (if necessary as on Commando models) and the right side cover (if fitted) to gain access to the tank filler cap and drain plug respectively.

2. Drain the warm oil out into a suitable receptacle. On the 1970 Roadster, the filter junction bolt must be removed to drain the oil tank.

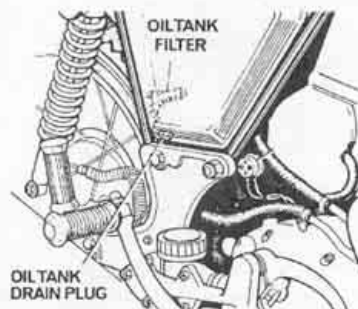

3. Remove the crankcase sump drain plug and allow the sump to drain completely. There should only be a pint or so of oil in the sump.

On early 1973 Commando 750 models, only a small drain plug is fitted to the sump. On the 850 Commando, a large plug with filter is fitted along with a smaller magnetic plug. This small plug should be removed and cleaned when the oil is changed.

4. Clean the sump filter by removing the spring clip, taking out the washer, and pulling out the filter mesh.

5. Wash the filter thoroughly in a suitable solvent to remove all impurities

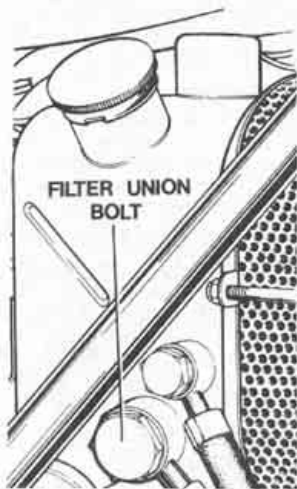

Roalster "S" tank filter bolt (1970)

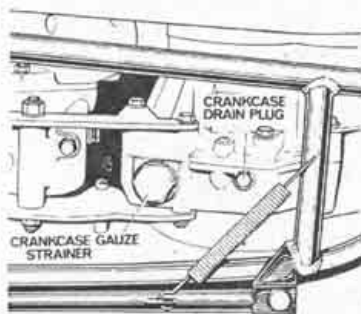

Drain plugs (850 shown)

trapped in it. Also wash out the plug itself checking closely for metal particles.

6. Reassemble the filter in the plug and replace. Tighten the plug firmly.

Commando only:

7. Remove the oil feed line at the tank by loosening the securing nut. Remove the filter (held by a circlip) and clean it. Let the filter dry before refitting it.

On some 1973 Commando 750s, and on the 850 Commando, an automotive-type screw-on cartridge oil filter is fitted to the oil return line, and is located behind the gearbox. This filter should be removed and replaced about every other oil change.

Place a drip pan beneath the filter to catch any oil. Loosen the clamp and unscrew the filter, using a filter strap wrench if necessary.

To install, place a thin coat of oil around the O-ring of the new filter and screw it on hand-tight only. Tighten the clamp. Do not overtighten the clamp as this risks crushing the filter.

Pre-Commando:

For the other models, the factory did not recommend removing the filter on the oil feed pipe as just described for the Commando for fear of causing a leak at this spot by breaking the seal. Instead, the recommended procedure was to remove the oil tank completely and wash it

out with kerosene or another suitable solvent.

a. Take off the metal oil pipe junction at the engine by removing the single fastening bolt.

b. Remove all other hose connections to the oil tank such as the crankcase breather, tank breather, etc.

c. Remove the three or four bolts which hold the oil tank to the frame (depending on the model) and remove the tank.

d. Flush the tank with the solvent several times to assure a complete cleansing job. Let the tank drain and dry thoroughly before refitting.

It is not necessary or recommended to perform this operation at every oil change. It should be done occasionally, though, and for certain if the engine has just been rebuilt.

Commando:

Although this should not be necessary for the Commando under normal conditions, the procedure is as follows:

a. Remove the seat and sidecovers from both sides of the machine.

b. Drain the oil as described above.

c. Take off the chain oiler pipe at the point where it enters the felt cartridge by compressing the spring clip and pulling the pipe away. Also remove the oil tank breather and crankcase breather pipes.

d. Unscrew the front and rear oil tank rubber mountings and remove the tank by lifting it to clear the bottom grommet and taking the bottom of the tank out of the frame first.

e. Reassembly is the reverse of the above procedure.

8. Occasionally check the filter in the oil pressure relief valve. To remove the valve, it may be necessary to take out the rocker oil feed banjo bolt immediately below it.

9. Refill the oil tank with the correct amount and grade of oil. Start the engine and let it run for three minutes. Then shut it off and let it sit for another two minutes. Recheck the oil level and fill it up as necessary.

GEARBOX

The change interval is 5000 miles. Oil should be warm when changing. Use SAE 90EP when average temperature is above 32° F and SAE 30 when it is below this.

Checking Oil

To check the level of oil in the gearbox, simply remove the oil level plug at the rear of the outer gearbox cover. The oil should begin to flow gently out.

Changing Oil

NOTE: The oil should be warm when changing.

1. Remove the clutch lever inspection cap on the outer cover.

2. Remove the drain plug at the bottom rear of the gearbox and allow the oil to drain out. Replace the drain plug and tighten it firmly, but avoid damaging the fiber washer.

3. Using a small funnel or other suitable device, add oil through the inspec-

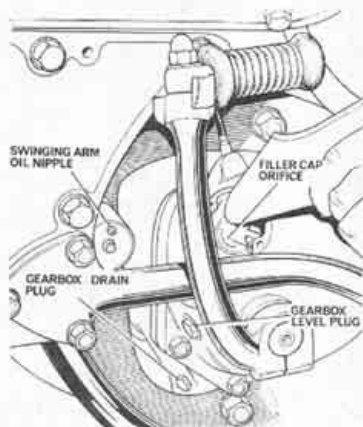

Gearbox plugs (all models)

tion cap. Add the oil slowly, as it is quite thick and must drain through a drilling in the inner cover to get to the gear compartment. When you have added the correct amount of oil (Commando: 1.2 pints; other models: 1 pint), let the oil sit for a minute to ensure that the level is equal in both the inner and outer compartments, then remove the level plug and check as before.

4. Replace the level plug and the inspection cap.

PRIMARY CHAINCASE

The change interval is every 2500 miles. Change when engine is warm. Use the same type of oil being used in the engine.

Checking Oil Level

To check the primary chaincase oil level, remove the oil level plug at the middle, lower portion of the chaincase. The oil should seep gently out the level is correct.

Changing Chaincase Oil

1. Remove the left-side footpeg.

2. Place a long metal tray or suitable substitute beneath the chaincase, unscrew the central fixing bolt, or the screws around the chaincase cover as on some models, and pull off the chaincase cover just enough to break the joint and let the oil escape.

3. Let the cover sit for a moment until as much of the oil as possible has drained out, then remove the cover.

4. Wash out the cover with kerosene or another suitable solvent.

5. Replace the cover, remove the chain inspection cap, and add the correct amount and grade of oil with the aid of a small funnel. Check the oil level as before.

The primary chaincase for the Commando should be filled with 7 oz. of oil, while on the other models, the correct amount is 4.5 oz.

Never use any type of oil additive or a thicker grade of oil in the primary chaincase in an effort to slow or stop a leak, or for any other reason, as these may affect the operation of the clutch.

CAUTION: Do not overfill the primary chaincase.

Norton

FRONT FORKS

The oil should be changed every 5,000 miles (Commando), or 10,000 miles (pre-Commando) and refilled with the recommended grade in the correct amount.

1. Remove the small drain screw at the bottom of one fork leg, having a suitable receptacle ready to catch the oil. Push the bike off the center stand and work the forks up and down to completely drain all of the oil in the fork.

2. Allow the oil to drain for several minutes, then replace the drain screw, paying attention to the fiber washer to avoid damaging it. Drain the other fork leg in the same manner.

3. The large filler plug at the top of each fork leg must now be removed. If necessary for your bike, remove the handlebars for increased accessibility to the plugs.

With the bike off the center stand, remove one of the filler plugs.

CAUTION: Do not remove both plugs with the bike off the center stand, or the forks will collapse.

4. Push down on the front end so that the spring and damper rod rise out of the fork leg.

5. Using two wrenches, remove the filler plug from the damper rod.

6. Put the machine on the center stand so that the spring and damper rod retract into the fork leg, which they will do when the forks extend.

7. Pour the correct amount of oil into the fork leg. Atlas and Commando: 5 oz in each leg; Scramblers: 6.5 oz in each leg.

Oil must be added slowly. It takes time for the oil to seep past the spring and into the slider.

An alternate method to hasten filling is to cover the plug hole with the palm of one hand and then pump the forks up and down slightly.

8. After the oil has been added, push the machine off the stand again to expose the damper rod. Screw the filler plug onto the rod as far as possible, then lock the damper rod nut against it. A little thread locking compound can be used on the filler plug threads, as this will ensure that the damper rod does not come loose in operation.

9. Put the bike back on the center stand and screw the filler plug into the fork leg and tighten firmly, repeat the procedure with the remaining fork leg.

DRIVE CHAIN

The rear chain receives some lubrication from the oil tank by way of the tank breather tube. On Commandos, a felt regulator is incorporated into the tube. A lubricant developed specifically for motorcycle drive chains, however, should be used at regular intervals.

GREASE NIPPLES

On all drum brake models, grease nipples are fitted to the front and rear brake cam pivots. These should be lubricated every 5,000 miles with no more than one stroke of the grease gun to avoid getting grease inside the drum.

Most models also need lubrication of the rear brake pedal pivot and a fitting is provided for this purpose. Grease the pivot every 2,500 miles.

At the same interval, give a few shots of grease to the speedometer drive on the rear wheel.

On Commando models only, there is a nipple on the right side of the swing arm bush housing. This should be attended to every 5,000 miles. Fill it with SAE 140 oil.

To check the swing arm oil level, remove the spindle locating bolt at the top, center, of the swing arm pivot. Fill with oil until it begins to come out of the bolt hole.

CAUTION: Be sure to use oil only; do not use grease.

CONTACT BREAKER POINTS

Battery and Coil Ignition

Every 5,000 miles, when checking or replacing the contact breaker points, apply some grease to the breaker cam and to the pivot posts.

At the same time, apply a small amount of light oil to the centrifugal advance mechanism bob weights at their pivots. The advance mechanism is behind the breaker point plate.

In both cases, use the grease and oil very sparingly so you won't foul the points in the process.

Magneto Ignition

The cam ring in the Lucas K2F magneto has two holes drilled into it in which are fitted very small fiber wicks which hold and distribute oil. They are fed by much larger pieces of fiber beneath the cam ring. Every 3,000 miles, add oil sparingly to the cam ring face. Less often, the cam ring may be removed after first removing the center bolt, prying out the points and breaker plate, and very gently pulling out the cam plate. It must be pulled straight out by hand. Removing the cam ring will allow you to oil the fiber elements directly. Do it sparingly.

If the wicks in the ring are missing, as may happen after many miles, the ring can be lightly greased for the same purpose.

Also apply a drop of oil to the breaker point pivot post.

SPEEDOMETER AND TACHOMETER CABLES

The speedometer and tachometer cables should be removed, cleaned, inspected, and lubricated with grease periodically.

1. Disconnect the cables at the instruments or the drive box.

2. Withdraw the cables, leaving the outer housings in place.

3. Clean the cables thoroughly in kerosene, then inspect them for fraying.

4. Completely coat the cables with light-duty grease except for the 6 in. nearest the instruments.

5. Reinstall the cables as removed.

STEERING HEAD BEARINGS

Late Model Commando

If the machine does not have a large chrome hexagon nut at the top of the steering stem, it is the latest design. The fork bearings are therefore ball journal type, but pre-packed with grease at the

factory which lasts for the life of the motorcycle. These bearings need neither lubrication nor adjustment of any kind.

All Other Models

Steering head bearing lubrication is necessary at intervals of about 20,000 miles. It is necessary to remove the fork legs and steering stem. Refer to "Chassis" for procedures.

REAR SHOCK ABSORBERS

The Girling rear shock absorbers are maintenance-free sealed units and cannot be disassembled. If a shock absorber weeps oil, it must be replaced.

On some early machines, the upper part of the spring might be greased if it grates against the metal dust cover.

WHEEL BEARINGS

The maintenance interval for both front and rear wheel bearings is 10,000 miles, at which time they should be removed, cleaned, inspected, packed with the approved brand of grease, and replaced. Removal procedure is given in "Chassis."

Service Checks and Adjustments

CLUTCH

The procedure is essentially the same for all models.

1. Remove the clutch activating lever inspection cap on the gearbox and the clutch adjusting screw cap on the primary chaincase.

2. Run the clutch cable adjuster all the way down until there is slack in the cable.

3. Check the free-play of the clutch activating lever in the gearbox outer cover. There should be about 1/8 in. of free movement before the lever touches the clutch pushrod.

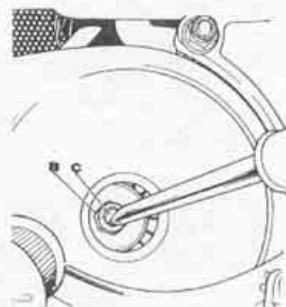

Clutch adjuster locknut (B) and adjuster (C)

4. Adjust, if necessary, by loosening the locknut on the adjusting screw in the center of the clutch hub.

5. Loosen the adjusting screw a few turns until you note the free-play in the gearbox lever.

6. Screw in the adjusting screw until it just touches the clutch pushrod.

7. On Commando models, back the adjusting screw off one full turn, then

Norton

tighten the locknut. On all other models, back the screw off $\frac{1}{2}$ to $\frac{3}{8}$ of a turn, then tighten the locknut.

8. Make sure that the activating lever has the required free-play. Take up the extra cable slack with the cable adjusters at the gearbox or the handlebar. There should be about $\frac{1}{8}$ in. of free movement in the handlebar lever before it engages the clutch for pre-Commando models. This is measured between the hand lever and the lever holder. On the Commando, there should be between $\frac{3}{16}$ in. and $\frac{1}{4}$ in. free movement between the cable outer casing and the adjuster.

BRAKE ADJUSTMENT

Commandos are fitted with either an hydraulic disc or a twin leading shoe drum-type brake at the front, and a single leading shoe at the rear on pre-1975 models. 1975 and later models have a disc at the rear wheel as well. Drum brakes are cable-operated on both wheels.

Other models usually had single leading shoe brakes front and rear, and the rear brake was rod-operated.

On all drum brakes, if the axle nut has been loosened, the brakes must be centralized in the drum before attempting adjustment. This is done by applying the brake hard with the axle nut loose, and then tightening the axle nut while keeping the brake applied. Then adjust the brake as outlined in the following sections.

Commando

FRONT, DRUM TYPE

1. Two adjusters are provided on the front brake cable: at the handlebar and at the drum itself. Usually, the adjuster at the drum is used to compensate for wear of the brake shoes.

Adjust the brakes so that the shoes contact the drum after the handlebar brake lever has moved about 1 in. (measured at the tip of the lever).

2. The angle formed by the cable and the brake plate lever should not exceed 90° when the brake is fully applied. If it does, it is probable that the shoes are worn to the point of replacement.

3. The link rod for the twin leading shoe brake should be correctly set at the factory, and does not require periodic adjustment. If the linkage has been disassembled, or if new brake shoes are fitted, reset the linkage by first removing the top clevis pin. Then pull the handlebar lever until the brake shoe just contacts the drum. Have an assistant hold the handlebar brake lever in this position. Push down on the upper brake plate lever until the brake shoe contacts the drum. The clevis pin holes in the link rod and the lever should line up, if the brakes are correctly adjusted. If not, loosen the link rod locknut, and screw the rod in or out so that the holes line up. Tighten the locknut. Insert the clevis pin and fit the clip. Adjust the brake with the brake plate adjuster.

NOTE: The pins should be checked periodically and replaced if they show signs of wear, or braking effectiveness will be reduced.

4. The front brake is equipped with an

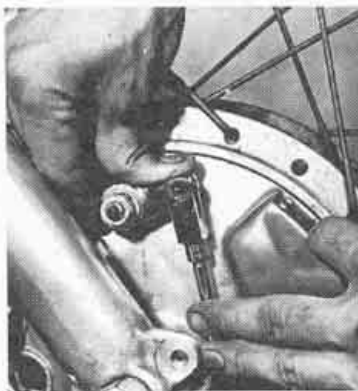

Adjusting the brake rod

air scoop and an outlet, both of which are blocked off. The plates can be removed if desired, but the wire mesh screens must remain in place.

FRONT, DISC TYPE

1. The only required check besides pad wear is for fluid level. The fluid level should be $\frac{1}{2}$ in. from the top of the reservoir. Add DOT 3 brake fluid only if topping up is necessary. Refit the diaphragm closed end down.

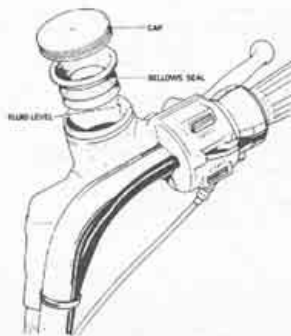

Disc brake fluid level should be $\frac{1}{2}$ in. below the lip of the reservoir

Note that the fluid level may drop slightly as the pads wear. In this case it is not necessary to add additional fluid, since the level will rise when new pads are fitted.

2. Bleeding and flushing procedures for the hydraulic system are provided in "Chassis."

REAR, DRUM TYPE

1. A stop bolt is fitted so that the brake pedal can be positioned to suit rider preference. Adjust this before adjusting the brake. If the stop bolt is moved, check operation of the brake light switch.

2. When the rear brake is fully applied, the lever should not be past the 6 o'clock position. If it is, new linings are necessary. The brake is adjusted with the adjuster on the end of the cable. Allow about 1 in. of pedal travel before the linings contact the drum.

3. Adjust the brake light switch after adjusting the brake. Loosen the securing screws and move the switch up or down as necessary so that the brake light goes

on as soon as the pedal is depressed.

4. Be sure that the brake pedal returns to rest against the stopper bolt, and not against the brake light switch, or the switch will be ruined. The switch plunger must *not* be fully compressed when the pedal is resting against its stop.

REAR, DISC TYPE

Check fluid level as outlined for "Front, Disc Type."

Pre-Commando

FRONT AND REAR

1. Adjust the front brake cable to allow about 1 in. of hand lever movement, measured at the tip of the lever, before the linings contact the drum.

The angle formed by the brake arm and the cable should not exceed 90° when the brake is fully applied, or the linings are probably worn to the point of replacement.

2. If the machine is equipped with a pedal stop for the rear brake pedal, this should be adjusted to the desired position first.

3. The rear brake, if rod-operated, must be adjusted with the motorcycle on its wheels and the weight of a rider on it. Allow about 1 in. of pedal movement before the linings contact the drum.

4. In all cases the wheels should be free to turn with no dragging from the brake linings.

PRIMARY DRIVE CHAIN

1974 and Earlier

On pre-Commando models, this adjustment should be made when the engine is at operating temperature.

1. Remove the primary chaincase inspection cap.

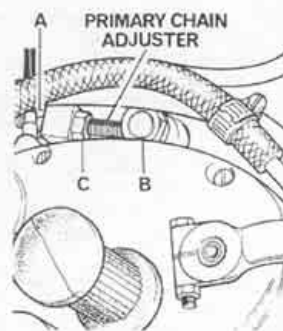

Primary chain adjuster locknuts (A&C) and locking bolt (B)

2. Loosen the large nut on the adjustment assembly on top of the gearbox. Also, loosen the nuts on the lower gearbox mounting stud.

3. On Scrambler models: screw down the adjuster bolt several turns. Pull down hard on the drive chain to take up the slack in the primary chain, then turn the adjuster bolt out until primary chain tension is correct. Tighten the lockbolt.

4. On other models: Back off the adjuster nut on the right several turns. Then tighten the nut on the left. The gearbox will pivot to the left to tighten the pri-

Norton

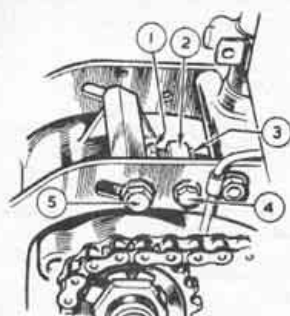

G15CS primary chain adjuster bolt (1), locknut (3), and gearbox lock bolt (5)

mary chain. Tighten the nut until the slack is completely gone, then back it off several turns and tighten the right nut until the correct chain slack is obtained. For Commandos this is $\frac{3}{8}$ in. total up and down movement. For models with single-row chains, $\frac{1}{2}$ – $\frac{3}{4}$ in.

5. Slowly rotate the chain and check the slack at several points. If the chain has a tight spot, the slack must be set to the correct specification at this point.

6. Tighten the large adjuster nut and the mounting stud nuts.

7. The final drive chain adjustment has been altered and must be checked.

1975 and Later

An automatic chain tensioner is fitted to the primary chain, so no adjustment is necessary.

FINAL DRIVE CHAIN

Before attempting adjustment, the chain must be clean and well lubricated. Check for tight spots and set slack at the tight spot, if any.

1. Loosen the rear axle nuts. Loosen the adjuster locknuts. Back off the rear brake adjuster (drum brake).

2. Pull down on the bottom chain run to ensure the wheel is aligned.

3. Turn each adjuster an equal amount until the chain is a bit looser than desired.

4. Check slack with the motorcycle on its wheels and a rider on it. Readjust, if necessary, until there is $\frac{3}{4}$ to 1 in. of slack (total up and down movement) measured in the middle of the bottom chain run.

5. Apply the rear drum brake, tighten the axle nuts and recheck chain slack. Tighten the adjuster locknuts.

6. Check that the brake is not dragging. On models with a rod-operated brake, the adjustment will have changed if the wheel was moved. Readjust the brake as necessary.

CAM CHAIN

1. Cam chain tension should be checked periodically. 1975 and later models are fitted with a plug on the timing case cover to allow the tension to be checked. On other models, the cover must be removed to check the tension.

2. Correct cam chain tension is $\frac{1}{8}$ – $\frac{3}{16}$ in. of total up-and-down movement measured in the middle of the upper chain run. Adjustment is by means of an adjustable slipper secured by two nuts.

Air Cleaner

1974 and Earlier

This is a paper element on most models, although it differs for each type of machine. Replace the filter paper every 5,000 miles or more often under dusty conditions.

On motorcycles like the Commando with its larger filter box, foam air cleaner elements can be fitted as a replacement. These are superior to paper filters and

can be reused by washing them in solvent and oiling as per instructions. Follow the filter manufacturer's recommendations if this is done.

1975 and Later

A foam-type air cleaner is used on these machines. Under normal conditions the filter should be serviced every 3,000 miles by removing it from the machine, washing it in clean gasoline, and squeezing dry. Then soak the filter in motor oil, squeeze off the excess, and install.

Periodic Maintenance Intervals

Weekly

Check tire pressure

Every two weeks

Check battery electrolyte level

Every 250 miles

Check engine oil tank level

Every 1,000 miles

Check primary chaincase oil level

Lubricate and adjust rear chain

Lubricate all control cables

Adjust both brakes

Check gearbox oil level

Every 2,500 miles

Check timing and adjust contact breaker points

Clean spark plugs and set gaps

Change primary chaincase oil and check adjustment

Check clutch adjustment

Change engine oil

Clean crankcase oil filter

Clean, lubricate, and adjust rear chain

Grease rear brake pedal pivot

Grease speedometer drive

Lubricate control cables

Every 3,000 miles

Lubricate magneto cam ring

Clean air filter (foam-type)

Every 5,000 miles

Change gearbox oil

Change oil in forks (Commando)

Check steering head bearing adjustment

Clean contact breaker points

Lubricate contact breaker cam and auto advance unit

Grease brake spindles (one stroke of grease gun)

Check and adjust valve rocker clearances

Check and adjust cam chain

Replace air filter element (paper-type)

Disassemble and clean both carburetors

Lubricate swing arm bushes (Commando)

Replace cartridge oil filter

Every 10,000 miles

Change oil in front forks (pre-Commando)

Re-pack wheel bearings with grease

Check front and rear rubber engine mountings for side play (Commando)

Maintenance Data

	Atlas	G15CS, N13CS, P-11	Commando			
			Footback	Roadster	SS Hi-Rider	Interstate
Fuel Tank (gal)	3.5	2.5	3.0	2.7, 3.0	2.3	⊙
Oil Tank (pts)	4.5	4.5	6.0	6.0	6.0	6.0
Gearbox (pts)	1.0	1.0	1.2	1.2	1.2	1.2
Primary Chaincase (oz)	4.5	4.5	7.0	7.0	7.0	7.0
Front Forks @ Leg (oz)	5.0	6.5	5.0	5.0	5.0	5.0
Tire Pressure (psi) ⊙						
Front	24	24	22	22	22	22
Rear	24	24	24	24	24	24
Chain Slack (in.)						
Primary Drive	$\frac{1}{2}$ – $\frac{3}{4}$	$\frac{1}{2}$ – $\frac{3}{4}$	$\frac{3}{8}$	$\frac{3}{8}$	$\frac{3}{8}$	$\frac{3}{8}$
Rear Drive	$\frac{3}{4}$ –1	$\frac{3}{4}$ –1	$\frac{3}{4}$ –1	$\frac{3}{4}$ –1	$\frac{3}{4}$ –1	$\frac{3}{4}$ –1

⊙ For two-up or extended high-speed operation, add 2 psi, front and 4 psi, rear to given pressures.
⊙ 750–6.0; 850–7.3

Recommended Lubricants

Engine and Primary Chain	SAE 20/50 or SAE 30W
Above 32° F	SAE 10/30 or SAE 20W
Below 32° F	
Carbox	SAE 90EP
Above 32° F	SAE 30
Below 32° F	
Front Forks	SAE 10-30 or SAE 20W
Swing Arm (Commando)	SAE 140
Grease Fittings	Waterproof, medium-weight chassis grease
Control Cables	10/30 motor oil Graphite-base lubricant Molybdenum disulphide-base lubricant
Tach, Speedometer Cables	Light-duty grease
Wheel and Steering Head Bearings	Waterproof, medium-weight bearing grease

Tune-Up

NOTE: Common tune-up procedures are explained in detail in "General Information."

Valve Adjustment

NOTE: Valves must be adjusted when the engine is cold.

1. Remove the gas tank after shutting off the fuel taps and disconnecting them at the tank. On some models, the seat must be removed first.
2. Remove the spark plugs, the two exhaust rocker covers, and the intake rocker cover.
3. Turn the engine over with the kick-starter until the left-side intake valve is fully open (the rocker arm will be depressed). The right intake valve will be closed at this point. Check the clearance at the right intake valve with a feeler gauge. It should be 0.006 in. for all models except Combat-equipped Commandos which are set at 0.008 in.

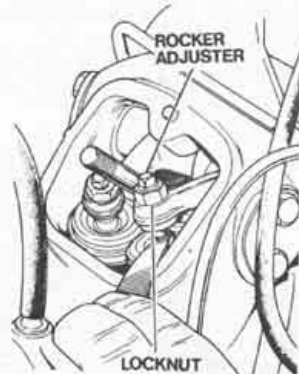

Adjusting the valves

The feeler gauge blade will be a slight drag fit in a correctly adjusted valve.

4. Adjust, if necessary, by loosening the locknut and turning down the adjuster until the feeler gauge blade can be pulled through with a slight drag on it.
5. Hold the adjuster in position and

tighten the locknut. Recheck the gap after tightening.

6. Turn the engine over until the right intake valve is depressed, then adjust the left intake valve.
7. Repeat the procedure with the exhaust valves. Proper exhaust valve clearance for all standard engines is 0.008 in. Combat engines are set at 0.010 in.

Contact Breaker Points

MAGNETO IGNITION

The contact breaker points are located beneath the magneto cover on the left-side of the machine.

Removal

1. Loosen the kill-button wire knurled nut at the magneto. This is attached to the post in the center of the magneto cover.
2. Unscrew the cover and place it aside.
3. Loosen the central hex-head securing screw until it is clear of its threads but is still in the center of the contact breaker. It can be used to "break" the points off their tapered shaft by gently levering sideways with the fingers.
4. When the points have been taken off the shaft, remove them completely.

Installation

Installation is the reverse of the removal procedure. Clean the new points with a non-oily solvent to remove the preservative coating. Do not forget to replace the fiber washers on the pivot post. Refer to the illustration for correct position of various parts. Also, apply a drop of oil to the post for lubrication. Note that the points assembly has a key which must fit in its slot. Set the gap upon installation. The ignition timing need not be re-adjusted.

Gap Adjustment

1. Turn the engine over slowly until the points are fully open. This should be done with care. The points will be open at two positions on the cam ring. These points can be determined by looking at the cam ring itself. There are two "thick" areas. The points will be open when the contact breaker heel passes over these points which are about 6 o'clock and 12 o'clock.

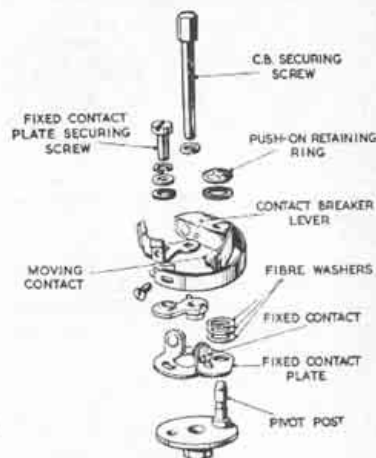

Magneto breaker points assembly

2. Loosen the fixed contact plate securing screw, then use a screwdriver to move the fixed contact plate to the correct gap. Check the gap with the appropriate feeler gauge. It should be 0.012-0.015 in.
3. Tighten the fixed contact plate securing screw and recheck the gap.
4. Check that the gap is the same at both open positions on the cam ring. If it is not, set the gap so that it is within the given specification at both open positions.

CAPACITOR IGNITION

Capacitor ignition systems (or battery and coil ignition) are found on 1967 models as well as on Commandos. The earliest machines equipped with this system had the ignition points located in a canister behind the cylinder barrels and attached to the timing case. The first machines utilized dual points with the condensers mounted on the breaker plate. This set-up was soon replaced with yet another system: Lucas 6CA dual points, individually mounted on the breaker plate, the condensers being remotely positioned. The points on this later system allow each cylinder to be timed separately. This system was used on Commando models also up to engine No. 131257, when the points were relocated to the timing case. Aside from the new location, the points assembly is the same.

Commando 750s (1973) and Commando 850s use another type of breaker point assembly, the Lucas 10CA.

Early 1967 Models

REMOVAL

1. Remove the ignition point cover.
2. If desired, the points assembly may be removed as a unit to reveal the automatic timing advance mechanism. Disconnect the two wires from the snap connectors; remove the two screws which secure the breaker plate and remove the plate.
3. If replacement of the points only is desired, remove the two wires from the snap connectors, release the nut which holds the spring of each breaker point to

Norton

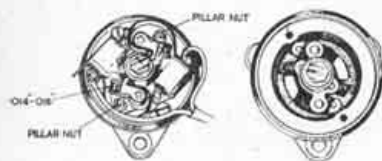

Early battery-and-coil breaker points and advance mechanism

its condenser, being careful of the insulating washers and their positions.

4. Remove the pillar nut which holds each breaker point onto the plate and take away the points.

INSTALLATION

Installation is the reverse of the removal procedure. Clean the new points with a solvent to remove the preservative coating. Be sure that all insulating washers are in their proper positions. Apply a drop of oil to the pivot posts.

NOTE: When refitting the contact breakers, assure that the wires are connected correctly. The yellow-black wire attached to the top contact breaker goes to the coil mounted on the left rear frame down tube. Also, the high tension lead from this coil goes to the drive side cylinder.

When refitting the contact breaker cover, be sure that the two insulated strips for each condenser are in position.

GAP ADJUSTMENT

1. Turn the engine over until one of the breaker points is fully open.
2. Loosen the pillar nut which secures the breaker point fixed plate.
3. Use a screwdriver to adjust the gap by prying between the fixed plate and the contact breaker housing.
4. Using a feeler gauge, set the gap for each breaker point at 0.014-0.016 in.
5. Tighten the pillar nut and recheck the gap.

Late 1967 Models and Commando 750 to Engine No. 131257

These models utilize the Lucas 6CA points assembly, located behind the cylinders.

REMOVAL

1. Remove the points cover.
2. If desired, the breaker points assembly may be removed as a unit to reveal the automatic timing advance mechanism by removing the two large screws which secure the breaker assembly plate.
3. To remove the points themselves, remove the hexagon nut which secures the wire and the contact breaker spring. Be especially careful of the plastic insulator sleeve and the fiber washer.
4. Remove the locking screw (D) and take off the breaker.

INSTALLATION

Installation is the reverse of the removal procedure. Ensure that the insulating washers and insulator sleeve are correctly positioned. Smear the pivot post with a bit of grease before refitting. Clean new points with a solvent to remove the preservative coating. When fitting the

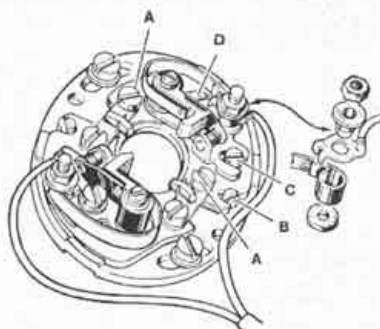

6CA points assembly

point cover, be sure it is seated on the rubber washer.

GAP ADJUSTMENT

1. Turn the engine over until the slash mark on the point cam aligns with the nylon heel of one of the breaker points.
2. Check the gap with the appropriate feeler gauge. It should be 0.014-0.016 in.
3. If adjustment is necessary, loosen the locking screw (D) and turn the eccentric screw (C) until the proper gap is attained.
4. Tighten the locking screw and recheck the gap.
5. Repeat the procedure for the remaining point set.

Commando 750 From Engine No. 131258 to 1972 Models

The points are located beneath the cover on the timing case. This is also a 6CA breaker set and the procedure for removal, replacement, and adjustment is exactly the same as described in the preceding section.

Commando 750 (1973) and Commando 850

These models use Lucas 10CA points assemblies driven off the camshaft.

REMOVAL

1. Remove the points cover.
2. To remove the points assembly complete, remove the two large screws which secure the breaker assembly plate. The ignition timing must be set upon installation if the breaker assembly plate is disturbed.
3. To remove individual points, disconnect the wire, being careful of the

plastic and fiber insulators at the terminal.

4. Remove the two screws which secure each set of points to the plate (C and D in the illustration).

INSTALLATION

Installation is the reverse of the removal procedure. Assure that the insulating washers and insulator sleeve are correctly positioned. Smear the pivot post with a bit of grease before refitting. Clean new points with a solvent to remove the preservative coating.

GAP ADJUSTMENT

1. Turn the engine over until the slash mark on the point cam aligns with the heel of one of the breaker points.
2. Check the point gap. It should be 0.014-0.016 in.
3. If adjustment is necessary, loosen the points securing screws (C and D), and move the point with a small screwdriver until the gap is correct.
4. Tighten the two screws and recheck the gap. Repeat the procedure with the other points set.

Ignition Timing

It is essential that the ignition points be in good condition and correctly gapped before the timing procedure is undertaken.

MAGNETO IGNITION

Adjusting Timing

1. Remove the left and right footpegs and the tachometer drive.
 2. Remove the magneto points cover after loosening the kill button wire nut.
 3. Place a pan beneath the primary chaincase cover and remove the cover.
 4. Take out all of the screws which secure the timing cover. Place a receptacle for oil beneath the timing cover and pull it off, being careful that the conical oil seal fitted to the oil pump nipple is not misplaced.
- Oil will dribble out of the drilling in the crankcase. It can be blocked off by inserting one of the cover screws.
5. Remove the spark plugs.
 6. Remove the alternator rotor nut and affix the timing disc to the crankshaft.

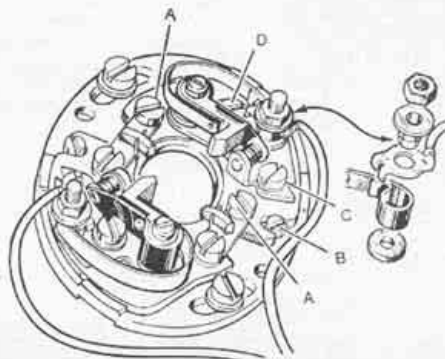

10CA points assembly

7. The pistons must be set to top dead center. Place your thumbs over the spark plug holes and kick the engine over slowly with the kickstarter until compression is felt in one of the cylinders. Now place a short drinking straw or a swizzle stick into that spark plug hole and turn the engine over using a wrench on the rotor nut until the piston's highest point has been ascertained. Work the pistons up and down several times until you are sure that you have it right.

NOTE: There will be about 4° of "loose" movement of the crankshaft which will indicate TDC.

8. Attach a stiff wire anywhere that is convenient so that it points to "zero" on the timing disc.

9. Loosen the self-extracting bolt on the timing advance mechanism until the points can be turned freely.

10. Using a small block of wood, or suitable substitute, lock the bob weights of the timing advance mechanism in the "full advance" position.

11. Turn the rotor nut clockwise until the pointer indicates 32° on the timing wheel.

12. Place a very thin piece of paper (cigarette paper is good) between the points and, tugging gently at the paper, assure that the points are closed, trapping the paper. Rotate the points with a wrench on the center nut, maintaining gentle pressure on the paper.

13. The very instant the points begin to separate, the plug will fire. With the small wrench, hold the points at the place that the paper slips out of the points.

14. Turn the self-extracting bolt on the timing advance mechanism with your hand until it is finger tight, then tap the bolt head lightly with a hammer so that the advance mechanism will lock onto the tapered shaft.

CAUTION: A light tap is all that is needed. Do not smack the bolt with any great force.

Tighten the bolt.

15. Turn the engine over once or twice, then recheck the timing.

16. Before reassembling the components, be sure to remove the block from the timing advance mechanism. Check the mechanism for free play.

NOTE: The correct amount of timing advance is 32° of crankshaft rotation which is equivalent to 0.343 in. (8.69 mm) of piston travel. It is possible to use this measurement if the head has been removed, but it would be inaccurate if an attempt is made to measure piston travel through the plug holes due to their angle.

Also, the point of separation for the ignition points cannot be determined with a test light due to the characteristics of the magneto. A special ohmmeter, however, can be used if one is available.

CAPACITOR IGNITION

Piston position can be found either with a degree wheel, or with marks on the alternator rotor, depending on model. The moment of point opening can be checked in a number of ways, the easiest being with a test light or a self-powered continuity light.

On later model machines, "dynamic" timing by means of an automotive-type strobe light is possible, and this method is preferable to the "static" methods, since it allows timing to be checked at the rpm at which the engine usually operates.

Early 1967 Models

CHECKING TIMING

1. Remove the left footpeg and primary chain cover, placing a pan beneath it to catch the oil.

2. Remove the spark plugs and the ignition points cover.

3. Fit the timing disc onto the crankshaft and place the pistons at top dead center. The left cylinder should be on the firing stroke, as indicated by compression in that cylinder as the piston approaches top dead center and clearance at both valves at TDC.

4. The timing, when fully advanced, is 32°. The advance mechanism is behind the points and it is therefore easier to check the timing in the unadvanced position. This is fine on machines which have not covered a large number of miles. In this case, rotate the crankshaft clockwise a few degrees past 8° as indicated on the timing wheel, then turn it counterclockwise. When the pointer indicates 8°, the points for the left cylinder should just be beginning to open. Verify this by using a test or continuity light.

For machines with this system which have covered a large number of miles, the timing should be checked in the full advance position since the advance unit stops may be worn. To lock the advance unit into full advance position, remove the bolt of the breaker cam and use a screwdriver to turn the cam clockwise until it stops. Using this method, the points should start to open at 32° before top dead center.

ADJUSTING TIMING

To set the timing, proceed as outlined above. Loosen the two securing screws which hold the contact breaker plate and move the plate in the needed direction until the points for the left cylinder begin to open at the correct time. The plate is moved clockwise to retard the timing, counterclockwise to advance it.

Be sure to check the timing on the other cylinder as well. If there is a difference greater than 1° between the two, position the breaker plate so as to split the difference.

Late 1967 Models and Commando Engine No. 131257

CHECKING TIMING

1. Remove the primary chain cover after taking off the left side footpeg and the exhaust pipe, if necessary. Catch the oil in a suitable container.

2. Remove the ignition points cover and the spark plugs.

3. Remove the alternator rotor bolt and fit the timing wheel.

4. Place your finger over the right spark plug hole and kick the engine over until compression is felt in the cylinder.

5. Insert a short drinking straw or a

swizzle stick into the plug hole and continue turning the engine over with a wrench on the rotor bolt until top dead center has been established. Rock the pistons back and forth a few times until you are sure that you have positioned them at the highest point of their travel. Check that the right-hand piston is on the compression stroke by noting clearance at both valves.

NOTE: There will be about 4° of "loose" movement in the crankshaft which will indicate TDC.

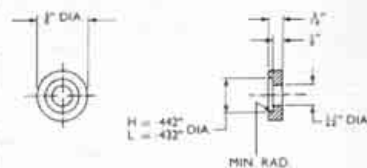

Washer for locking timing advance unit

6. Remove the center bolt of the contact breaker cam and find a washer with a hole large enough to fit over the cam post and bear on the cam itself. Replace the bolt and this washer, turn the cam clockwise to the full advance position, and tighten the bolt. This should lock the cam in the advanced position.

7. Using a piece of wire as a pointer, position it anywhere that is convenient so that it indicates "zero" on the timing disc.

If you have placed the right cylinder piston at TDC on the compression stroke, you will be working with the points with the black/white primary wire. Hook up the test or continuity light.

8. Rotate the crankshaft backward by turning the rotor nut clockwise several degrees past the normal timing advance as indicated by the degree wheel. This will be either 32° or 28° depending on the model. Turn the crank to about 40° before TDC to assure that the points are closed.

9. Slowly turn the nut counterclockwise until the timing wheel indicates the correct reading. At this very point the test light bulb should react, for they will commence to open if the timing is correct.

10. Repeat this procedure for the left cylinder.

ADJUSTING TIMING

If the points do not begin to open at the correct time, refer to the illustration of the 6CA points assembly.

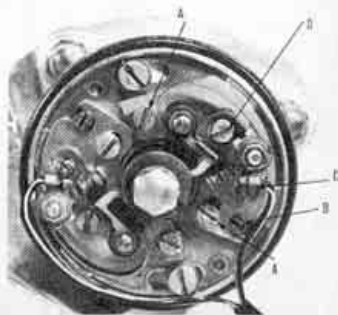

6CA points assembly

Norton

1. Loosen the two securing screws (A) and turn the brass eccentric screw (B) until the points open at the correct time.

2. If the correct timing cannot be attained in this manner, set the contact breaker at about the middle of its adjustment range using screw (B), then tighten the securing screws.

3. Loosen the large screws which hold the contact breaker plate to the housing and rotate the entire plate until the points begin to open.

4. Secure the two screws. Turn the engine over 360° and adjust the other points set as previously described. It should not be necessary to move the entire breaker plate again, only the individual point set.

Commando Models After Engine No. 131257

These machines have the points assembly mounted in the timing case on the right side of the camshaft and are fitted with a timing mark on the rotor and an indicator plate beneath a cap at the front of the primary chain cover. The system may be checked for proper timing either with the engine running or at a standstill.

CHECKING TIMING

1. Remove the points cover and the inspection plug from the primary chaincase.

2. Hook up a strobe light in accordance with the manufacturer's recommendations.

3. Start the engine and run it at 2,000 rpm so that the timing is fully advanced. The mark on the rotor should register with the 28° mark on the indicator plate. (Each line indicates two degrees.)

4. If no strobe light is available, the engine can be checked at rest. Remove the points cover and the inspection cap on the primary chaincase.

5. Remove the spark plugs. Remove the intake valve rocker cover. Rotate the engine until the drive side (left) intake rocker opens and closes. This will place the drive side cylinder on the firing stroke.

6. Remove the center bolt of the contact breaker cam. With a washer which has a hole large enough to clear the cam post and bear on the cam itself, replace the bolt, turn the breaker cam until it is in the full advance position, and then tighten the bolt.

7. Connect a test light to ground and to the terminal of the LEFT contact breaker (black/yellow primary wire) and rotate the engine until the indicator plate on the primary chaincase reads 28°. The test light bulb should react at this point as the points separate.

8. Repeat the procedure to check the timing for the right cylinder.

ADJUSTING TIMING

1. Proceed as above. If the points do not open at the correct time, refer to the illustration of the Lucas 6CA or 10CA points.

2. Loosen the securing screws (A) and turn the brass eccentric adjusting screw (B) until the points open at the proper time. Tighten the screws.

3. Rotate the engine 360° and repeat the procedure for the other cylinder.

4. Be sure to remove the breaker cam bolt and the oversized washer, replace the standard washer, and tighten the bolt. Make sure that the advance mechanism works freely.

IGNITION TIMING—WHEN TIMING HAS BEEN LOST

1. If, for any reason, the breaker cam assembly has been removed from its shaft (and this applies to all models equipped with the 6CA or 10CA points system), it is necessary to align it in approximately the correct position before timing can be accomplished.

2. Referring to timing information previously given, locate the drive side (left) cylinder on its compression stroke, and place the piston at 28° before TDC.

3. Place the breaker cam assembly onto its shaft so that the bobweight pivots of the automatic timing advance mechanism line up with the point assembly cover screw holes (see illustration). The slot on the cam face (not the timing slash mark, but the slot) will be at approximately nine o'clock.

4. Set the ignition timing as previously described.

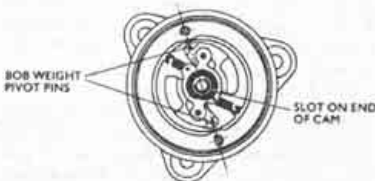

Correct location of timing advance unit

Carburetor Adjustments

These should be made after the other items in this section have been checked, and when the engine is at its normal operating temperature.

IDLE SPEED AND MIXTURE

1. Turn the pilot air screws in until lightly seated, then back them out about 1½ turns.

2. Turn in the throttle stop screws until idle speed is slightly higher than normal.

3. Remove one of the spark plug leads. Keep the engine running on one cylinder by turning in the throttle stop screw for that cylinder until the engine runs, but as slowly as possible.

4. Turn the pilot air screw in or out until the exhaust pulse from the running cylinder is smooth and even.

5. Connect the spark plug lead, rev the engine a few times to clear it out, then disconnect the lead to the cylinder which has been adjusted.

6. Repeat the previous procedure so that the running cylinder fires as slowly and evenly as possible.

7. Connect the lead. Both cylinders will be running and idle speed will be

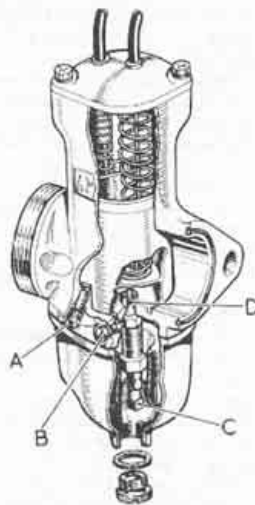

Concentric carburetor throttle stop screw (A), pilot air screw (B), main jet (C) and needle jet (D)

very high. Back out each throttle stop screw by equal amounts until the desired idle speed is reached.

8. Check that both cylinders are firing evenly.

CARBURETOR SYNCHRONIZATION

1. Remove the air cleaner assembly.

2. Twist the throttle fully open to lift up the slides.

3. Position a mirror behind the carburetors or reach into the carburetor bores with the thumb and index finger of one hand.

4. Slowly close the throttle and watch, or feel, the slides as they are being lowered; they should enter their respective bores simultaneously.

5. If the slide positions are unequal, raise or lower one to match the other by turning the adjuster at the top of the carburetor.

6. Another check is to place a finger on each carburetor slide when the throttle is fully closed, then move the twist grip very slightly. Both slides should begin to lift at the same time. Adjust as described above if necessary.

THROTTLE CABLE ADJUSTMENT

On most models, the cable runs from the twist-grip to a junction block, where two shorter cables run to the carburetor tops. One end of each cable is equipped with an adjuster. These are located at the twist-grip and the carburetor tops.

Adjust the long cable so that there is about 2 mm of free-play before actuation.

Adjust the short cables so that there is as close to zero free-play as possible. Check carburetor synchronization as previously described.

After setting the free-play at each cable, start and warm up the engine. Turn the handlebars from side to side and notice any variation in rpm. If a variation occurs, one of the cables is either incorrectly adjusted (not enough free-play) or is binding somewhere along its routing.

Norton

Tune-Up Specifications

	Magneto Ignition	Capacitor Ignition (pre-Commando)	Commando (Standard)	Commando (Command)
Carburetion	Refer to "Fuel System" for standard carburetor settings			
Valve Tappet Clearance (cold)				
Intake (in.)	0.006	0.006	0.006	0.008
Exhaust (in.)	0.008	0.008	0.008	0.010
Ignition				
Spark Plug (standard)				
Champion	N5	N5	N6Y-N7Y	N7Y
Plug Gap (in.)	0.015-0.022	0.023-0.028	0.023-0.028	0.023-0.028
Breaker Point Gap (in.)	0.012-0.015	0.014-0.016	0.014-0.016	0.014-0.016
Ignition Timing (full advance) BTDC	32°	32°	28°	28°

Engine and Transmission

It is important to realize that although the procedures for working on the Norton engine are applicable, with minor variations, to all models, the engine components are usually not interchangeable between Commando and pre-Commando units, even though they may be similar in appearance. Be sure that the correct replacement parts are obtained when necessary.

NOTE: For engine component inspection procedures, refer to "Engine Rebuilding" under the General Information section.

ENGINE SERVICE NOTES

1. On all models, the cylinder head and cylinder can be removed without removing the engine from the frame.

2. The clutch and primary drive and timing case components are also accessible for service with the engine in the frame.

3. All transmission components with the exception of the left-side countershaft (or layshaft) bearing can be serviced without removing the transmission.

If necessary, the transmission itself can be removed without disturbing the engine.

4. Most engine work requires only standard tools and a torque wrench. A variety of pullers are needed.

To remove the Commando diaphragm clutch, a special tool *must* be used for safety reasons.

Engine Removal and Installation

COMMANDO

The engine unit may be removed without disturbing the transmission, and this is the easiest method, since removal of the complete assembly requires removal of the rear wheel and swing arm.

1. Remove the seat and fuel tank.
2. Drain the oil from the tank and disconnect the oil pipe junction (one bolt) at the engine. Some oil will come out when the junction is removed.

3. Remove the spark plugs. If necessary, as on late models, unbolt the ignition coil pack and hang it out of the way.

4. Disconnect the tachometer cable at the engine.

NOTE: On early Commandos with the tach drive box mounted on the outside of the timing case, it is preferable to remove the box itself rather than just the cable, since it is vulnerable to damage if the engine is dropped.

5. Remove the carburetors complete with manifolds and hang them out of the way by the throttle cable.

6. Remove the exhaust system.

7. Remove the small, engine head steady plates. On models with rubber mounts here, loosen the rubber mount nuts first. Remove the head steady plate from the cylinder head.

8. Remove the gearshift lever.

9. Remove the battery cover. Disconnect the positive terminal of the battery to eliminate the possibility of a short.

10. Disconnect the alternator leads at the snap connectors.

11. Remove the left-side footpeg and the rear brake lever. Remove the primary chaincase cover and remove the alternator, clutch, sprocket, and chain. Refer to "Clutch and Primary Drive."

12. Disconnect the crankcase breather from the engine.

13. Disconnect the ground wire attached to the bottom crankcase stud on the left-side, if fitted.

14. Before removing the mounting plate bolts, provide some means of support for the engine or it will drop several inches before hitting the lower frame rails. A block of wood placed beneath the crankcase is a good idea.

15. Take off the self-locking nut from the bolt which passes through the front engine mount. Withdraw the bolt from

the right-side of the frame. Remove the front engine mounting assembly.

16. Remove the rear crankcase mounting nuts and studs, lifting the unit to remove the bottom most stud. Remove the unit from the right-side of the frame.

Installation of the engine and transmission is basically a reversal of the removal procedure.

17. Place the engine in the frame from the right-side of the motorcycle.

18. Fit the three studs and nuts which pass through the rear engine mounting and the crankcase.

19. Supporting the engine, place the front engine mounting assembly in position.

20. Insert the front engine mounting bolt and tighten the self-locking nut to the correct torque setting. Tighten the nuts on the three rear engine mounting studs.

21. Continue reassembly in the reverse of the sequence described for removal.

22. The washers for the finned exhaust pipe nuts should be replaced.

23. Be sure that the exhaust pipe finned nuts are tightened securely. These nuts are best looked after by safety wire fastened by drilling one lobe of the nut and the top cylinder head fin.

24. Check all nuts and bolts for tightness before and after a short ride.

ATLAS

To remove the Atlas engine and transmission as a unit, follow this procedure:

1. Remove the gas tank, disconnecting the fuel lines at the carburetors and taking off the mounting nuts.

2. Remove the head steady bracket.

3. Remove the air cleaner and the carburetors.

4. Drain the oil tank and the engine sump. If work is to be performed on the transmission, drain it also.

5. Unbolt the oil pipe junction at the crankcase. Kicking the engine over a few times after draining the oil tank and before removing the junction will minimize the amount of oil which will dribble out.

6. Remove the exhaust pipes and mufflers.

7. Disconnect the tachometer drive (two screws) at the engine. It is advisable to remove the drive rather than just the cable to avoid hitting it on something as the engine is removed from the frame.

8. Disconnect the battery leads and remove the battery.

9. Remove the rectifier, being very careful of the rectifier bolt.

10. Remove the battery box.

11. Disconnect the crankcase and tank breather hoses to the oil tank and remove the tank (4 bolts).

12. Remove the oil tank platform.

13. Remove the clutch activating lever inspection cap at the top left-hand side of the transmission, pry up the lever with a suitable screwdriver (taking care not to damage the edges of the inspection hole), and remove the clutch cable. Screwing the cable adjuster all the way in makes the job easier. Next, remove the adjuster from the case.

14. Remove both footpegs. Place a pan beneath the primary chaincase cover to

Norton

catch the oil when it is removed. Remove the large hexagon nut on the footpeg stud and carefully take off the chrome cover and the rubber washer. Pull off the chaincase cover.

15. Disconnect the alternator leads at the snap connector.

16. Remove the clutch pressure plate by unscrewing the three spring adjustment nuts. These are cylindrical and have two small tabs on the face that bears against the clutch spring to prevent loosening during operation. Removing the nuts will invariably shear off the tab, making replacement of the nuts advisable. If you must reuse the nuts on the clutch, a knife blade or suitable substitute can be placed between the nut and the spring while removing.

17. Remove the clutch springs and cups.

18. Remove the main clutch nut on the transmission mainshaft and the lock washer. Prevent the hub from turning either with the special tool or by applying the rear brake with the transmission in gear.

19. Remove the three nuts and washers which secure the alternator stator to the stator housing. Pull off the stator.

20. Remove the nut which secures the rotor to the crankshaft and remove the rotor and its woodruff key. A small gear puller is sometimes needed to take the rotor off of the shaft.

21. Disconnect the primary chain. The clutch hub may require a special puller to remove it from the transmission mainshaft, especially if it has not been removed before. In addition, the engine sprocket is fitted onto a tapered portion of the crankshaft and will definitely require a puller. A smaller gear puller can be used in place of the factory sprocket extractor. Be sure to remove the engine sprocket woodruff key.

22. Remove the three screws which fix the stator housing to the mounting plate and the three screws fixing the plate to the crankcase.

23. Remove the nut which is found about halfway between the engine sprocket and the clutch which secures the inner chaincase half.

24. The inner chaincase half is also secured by means of a tab by the nut on the bottom transmission stud. Remove this nut and take away the chaincase half. Disconnect the final drive chain.

25. Proceeding to the four bolts which fasten the upper and lower arms of the engine mounting plates (just before the swing arm), remove the lower bolts and loosen the upper two.

26. Remove the two studs, two bolts, and their respective nuts at the front engine plates.

27. Remove the two bolts which pass through the center stand mounts and the engine mounting plates. Lift the engine and remove the front mounting plates.

28. Remove the engine assembly from the frame.

29. Installation is the reverse of removal.

SCRAMBLERS

For engine service on Scrambler mod-

els, note the following points:

1. The engine and transmission are best removed as a unit.

2. The primary chaincase can be left intact during removal.

Refer to removal procedure for Atlas models for initial steps if additional information is needed.

1. Prepare the engine and transmission for removal in the manner outlined for the Atlas, removing the gas tank, exhaust pipes and mufflers, air cleaners, carburetors, oil from tank, and sump.

2. Remove the tachometer drive from the engine, clutch cable at the transmission, oil junction, oil tank and crankcase breather pipes, and alternator connections.

3. Disconnect the rear drive chain.

4. Remove the metal cover over the transmission.

5. Remove the upper front engine mounting bolts. Loosen, but do not remove, the lower front mounts.

6. Remove the right side footpeg and remove the rod from the left side. There are two spacers involved.

7. Unhook the center stand spring.

8. Remove the left side rear engine mounting bolts.

9. Raise the engine slightly to take the pressure off of the lower front bolts which are still in place and remove the nuts. Take away the engine plates, watching for the spacer.

10. Lever the engine forward and lift it up and out of the right side of the frame.

11. Installation is somewhat simplified by first removing the skid plate.

Before replacing the engine in the frame, be certain that the left side footpeg is in its proper position since it cannot be replaced after the engine is in the frame.

12. Begin by placing the engine in the frame from the right side of the bike, rear end first.

13. Insert a length of steel rod or a suitable screwdriver through the rear engine plates and the frame to align the bolt holes.

14. Lever the front of the engine up to replace the lower small mounting bolt and tighten the nuts firmly.

15. Lower the engine and refit the front and rear engine plate bolts.

16. The remainder of the installation procedure is the reverse of the removal procedure.

Top End

REMOVAL

The following procedure gives instructions for removing the head with the engine in the frame.

1. Remove the seat and gas tank. Disconnect the spark plug leads, remove or loosen the plugs; remove the exhaust system.

2. Remove the coil pack, if fitted.

3. On Commando models, remove the head steady side plates, unscrewing the rubber mounting nuts first. Remove the head steady plate from the head.

4. On pre-Commando models, unbolt

the head steady from the head and the frame, and remove it.

5. Disconnect the rocker oil feed pipe on each side of the head.

CAUTION: Each junction has two copper washers. A rag placed over the spark plug hole is a good idea when removing the banjo bolts.

The rocker oil feed pipe must be placed out of the way so that the head can be removed. On models with neoprene lines, this is not a problem. Earlier machines, however, are equipped with a copper pipe to feed the rockers. This pipe is only flexible to a certain degree. It can be bent out of the way, but take care to avoid crimping it anywhere along its length. The alternate method is to also disconnect the pipe banjo at the crankcase and turn the pipe aside.

6. Remove the exhaust rocker covers and the intake rocker cover.

7. Remove the air cleaner, the carburetors, and the manifolds.

8. On magneto models, removing the front spark plug lead is a good idea.

NOTE: On Scrambler models, additional steps must be taken at this point.

a. Remove all of the cylinder head nuts and the bolt on the center of the head. This will leave only the four bolts flanking the spark plug holes;

b. Remove both exhaust rocker spindle retaining plates and remove the spindles. This requires a special tool. Refer to a following section. Be extremely careful of the washer and spring which are found on the spindle;

c. Remove the four remaining cylinder head bolts.

The remainder of the procedure is the same as that for other models.



Cylinder head tightening sequence; reverse the order when removing the head

9. The cylinder head can now be taken off. It is secured to the cylinders by five bolts and nuts. First position the pistons at TDC. Loosen the bolts and nuts gradually and in the reverse of the tightening order shown. There are two long nuts concealed in the fins which require an especially thin wrench to reach them.

As the last of the fasteners is loosened, the head should begin to rise off its seat slightly, due to the pressure of the valve springs. If the head is not free after the last of the fasteners has been removed, it is probably due to carbon build-up as on engines with many miles on them or those with an oil burning problem. In this event, place a block of wood against the cylinder fins at the exhaust port (the fins are strongest here) and rap sharply with a hammer.

10. The head must be removed very carefully. Remember that there are two

studs at the front of the cylinder barrels and three shorter ones in the head itself which must clear. The most important consideration at this point, however, is the pushrods.

11. Straddle the bike. Lift the head several inches off its seat. Slipping your fingers between the head and barrels, push the four pushrods up into the head as far as they will go. They should only protrude about two inches from the head.

12. Pull the head straight up as far as possible and tilt it backward and to one side until two of the pushrods clear their tunnel. Then tilt it to the opposite side so that the other two are clear. After both sets are out of the tunnels, the head can be taken out to one side.

NOTE: The pushrods are of two lengths. The longer ones activate the intake rockers. These are placed closest to the center of the barrels. Be certain they are correctly located upon reassembly.

13. The barrels can now be removed. Loosen all nuts securing the barrels to the crankcase. There are nine of them, except on the 850 Commando which has four allen bolts. These should be removed first.

Remove the nuts at the front of the barrels. The others must be loosened as much as possible until they hit the cooling fins. Lift the barrels as much as you can, then loosen the nuts again. Continue until the nuts can be taken off of the studs.

As soon as you have removed the nuts, remove and account for all washers. Be sure that none are left on the barrels, or one can easily fall into the crankcase later.

14. Lift the barrels clear of the crankcase. Ordinarily, the pistons will ride up with them if the transmission is in Neutral. As soon as there is enough room to do so, place a clean rag between the barrels and the crankcase covering the studs. This will catch any pieces of broken piston ring, if there is one, and will lessen the chances of the pistons damaging themselves on the studs as the barrel is pulled off.

CYLINDER HEAD

Maximum allowable warpage across the mating surface is 0.002 in.

ROCKER ARMS

Removal

1. For each rocker arm, remove the rocker spindle retaining plate assembly.

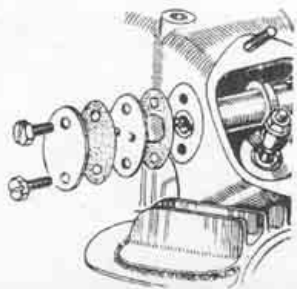

Rocker spindle retaining plate assembly

This consists of an outer plate, a gasket, an inner plate with two tabs to engage the slots of the rocker spindle and assure it maintains its position, and another gasket. Each element in this assembly is different. Note each position carefully.

In most cases the parts will remain together when removed, and need not be taken apart.

2. The rocker spindle is press-fit on the cylinder head. First note the position of the slots in the spindle end. Removal is made much easier, and there is less chance of scoring the spindle or the head, if the head is heated first. Ideally, the head should be placed in an oven and heated to not more than 100° C (212° F). In the case of the Scrambler models, where the factory recommends removing the exhaust rocker spindles prior to removing the head (engine in the frame), a propane torch can be used, with caution, to heat the area around the spindle very gently.

The spindles must be removed with a puller. They are threaded internally to accept special tool no. 064298 for late models. Earlier units could accept the pre-Commando cylinder head bolts (9/16 in W). To remove the spindles, a bolt, a locknut, and a short steel sleeve (or pre-Commando clutch spring cup), can be used as a puller. Thread the locknut most of the way up the bolt, then insert it into the sleeve or spring cup. Screw the bolt as far as possible into the spindle. Tightening the locknut will draw the spindle out of the head.

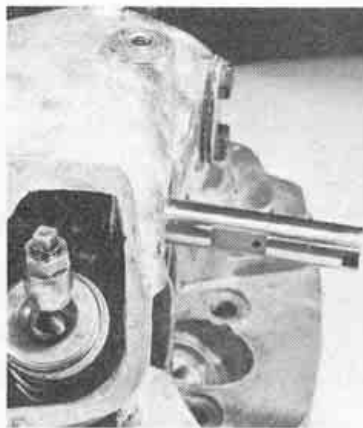

The oil hole in the spindle must face AWAY FROM the center of the head.

4. The rocker arm is flanked by a spring washer, fitted on the side closest to the center of the head, and a plain thrust washer on the opposite side. Be positive that both are accounted for. The thickness of the plain thrust washer should be 0.015 in.

NOTE: The exhaust rockers can be taken directly out of the head after pulling out the spindle. The intake rockers must be turned upside down and then removed on older models.

6. The ball end is press-fit in the rocker arm. To remove it, support the rocker arm on an appropriate surface to prevent damage to it, then drive the ball

shaft out with a drift. The rocker arm has a drilled oil passage from the spindle to the ball end to lubricate the ball and pushrod cup. Make sure that this passage is clear. Also, note that the ball shaft's oil hole must line up with the oil drilling in the rocker. To reassemble, press the ball shaft into position as far as possible. A standard bench vise faced with wood will do the job.

Installation

The rocker arm assembly must be installed correctly or damage to the components will result.

1. The rocker spindle must be located so that the slots on the outer end are HORIZONTAL; the oil hole on the spindle must face away from the center of the head.

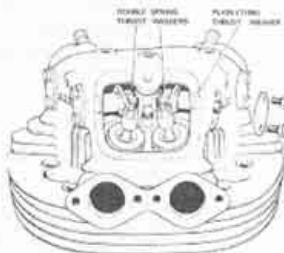

Rocker arm spindle spring and thrust washer installation

2. Fit the spring washer, the rocker arm, and the thrust washer in their proper locations. Remember that the spring washer is closest to the center of the cylinder head.

3. Heat the head, as was done on removal, and press in the spindle. Make sure that the spindle slots are horizontal to engage with the tabs on the spindle locating plate. Also, check to make certain that the spindle is just below flush with the gasket face on the cylinder head.

4. Fit the spindle locating plate. The correct order, from the head out, is:

- Paper gasket with large center hole
- Plate with locating tabs
- Paper gasket
- Plain oval plate
- Two fixing bolts

If oil leaks from the locating plate assembly, it may be due to the spindle protruding even slightly from the head, or the plates themselves may be warped. A late modification has been the fitting of copper washers beneath the plate bolts (Part No. 063129). These may be fitted to all previous models.

VALVES AND VALVE SPRINGS

Removal

1. Take out the stud for the intake rocker cover if you are going to remove the intake valves.

2. Using the valve spring compressor, compress the springs far enough to remove the two tapered valve keepers (collets) and release the spring.

3. The valve collar, inner and outer springs, spring seat, and heat insulating washer can be removed. Keep each assembly separate so that the components

Norton

can be reassembled together and in their original location.

4. Remove the oil seals from the guide, if fitted. Remove the valve.

5. Intake valves are larger than the exhaust valves, so telling them apart is no problem. The Commando valves, however, are about 0.07 in. longer than those found on previous models, with a corresponding decrease in the length of the pushrods. The shorter valves can be fitted to the Commando, if necessary, provided that a winkel cap of the proper thickness is installed.

Commando valves cannot be fitted to a pre-Commando engine. The pushrods for Commando and pre-Commando models are in no way interchangeable.

6. Check the valve spring free length, for both inner and outer springs, against the figures given in the technical data. If the measured length is less than 0.187 in. from the standard value, the spring must be replaced. Note that valve springs should be replaced as a set.

Installation

NOTE: The valve springs are progressively wound, and are installed with the close coils towards the cylinder head.

1. Put some clean oil on the valve stem and place the valve in the guide.

2. Refit the valve seal, if so equipped. New seals must always be used.

3. Replace the heat insulating washer in its seat, then, the valve spring seat, the springs (close coils against the head), and the spring collar.

4. Compress the spring and slip the two keepers into place.

VALVE GUIDES

Removal

Nortons are equipped with cast iron guides, the newer models being fitted with guides grooved to accept an oil seal on the intake side.

All 750 models have a flange around the guide which rests against the surface of the head when the guide is installed. The 850, however, has a spring clip around the guide which accomplishes the same purpose.

Valve guide to valve stem clearance is 0.002-0.004 in.

1. To remove the guides, strip the head of valves, springs, rocker arms, etc.

2. Heat the head on a hot plate or in an oven. This is essential as the guides are force fit in the head and any attempt to drive them out without heating is sure to result in either a broken guide or a scuffed or enlarged guide bore. Do not heat the head in excess of 200° C.

3. Use a drift to drive out the guides.

If the guides are broken, or have a great amount of carbon build-up as in the case of the exhaust guides, some difficulty will be encountered in removing them. If this is the case, use a chisel to break off the lower portion of the guide which protrudes into the port.

This operation should be an emergency recourse undertaken only after the standard procedure has been attempted.

Installation

1. To replace the guides, again heat the head to 200° C. The guide must be accurately inserted in the bore so that the valve can seat properly. To accomplish this, take the valve, which will be used in the port on which you are working, and place it in its normal seated position. The valve stem will be used to locate the valve guide in the head as it is driven in. Use the drift again, this time from the other end, and press home the guide until the flange or clip, abuts against the head. Guide bore size on all models is 0.3135-0.3145 in. Use the appropriate ream after installation.

NOTE: The newer Commando 750s have been fitted with oil seals on the intake guides to eliminate the oil burning which was a problem on some motorcycles. The guides are grooved to accept these seals which must not be fitted on the exhaust side. These guides are identical in other respects to the previous units, so changing over to a seal-type is possible, if so desired, by simply replacing the old guides with the new units.

The 850 is also fitted with oil seals on the intake valve guides, although this guide differs from the earlier one (being fitted with a circlip instead of a flange). In both cases, the oil seals go on the intake side only.

Oversized outside diameter guides are available, if needed, in the following sizes over standard: 0.002 in., 0.005 in., 0.010 in., and 0.015 in.

TAPPETS

Removal and Installation

1. The tappets, which are located at the front of the cylinder block, can be checked in place, or removed by cutting the safety wire and taking out the two screws.

The tappets will come out along with the keeper. Note its position for installation.

2. Since tappets are machined in pairs, it is imperative that they be kept together. If either is damaged, they must be replaced in pairs.

3. Grinding or finishing of the stellite pad which contacts the camshaft is not recommended. Replace the tappets if damage occurred.

4. When installing, note that the beveled edges of the tappets (running from top to bottom) must face the front of the engine. Use safety wire after tightening the screws.

CYLINDER

1. Measure the bore at the top (½ in. below the lip), middle, and bottom in two directions 90° apart.

2. Rebore the cylinders if the difference between the largest and smallest of the measurements is 0.005 in. (0.13 mm) or greater, or if any of them is 0.008 in. (0.20 mm) greater than the standard bore diameter specification.

3. Pistons for 750s are available in four oversizes in increments of 0.010 in. and 0.010 and 0.020 in. for the 850.

4. When boring, set piston-to-cylinder clearance at 0.0045 in.

PISTONS AND RINGS

Removal

NOTE: Mark the pistons "L" or "R" and the front or rear to facilitate installation.

1. Remove the piston pin circlips.
2. Heat the piston crown gently and evenly. Heat only the crown, not the skirt. Push out the piston pin.

Inspection

1. Ring side clearance should be 0.0015-0.0035 in.

2. Ring end-gap should be 0.012-0.013 in. Replace the rings if the compression ring gap exceeds 0.014 in.

On multi-piece oil rings, the rails may have an end-gap of 0.010-0.040 in.

Installation

1. The design of the piston rings has been changed several times over the years. The top compression ring is chromed on most models, or red-coated.

NOTE: Do not remove the red coating if present.

2. On late models the lower compression ring is tapered, while on others it may be stepped. Be sure the rings are installed with the "Top" mark facing upwards. Stepped rings are installed as illustrated.

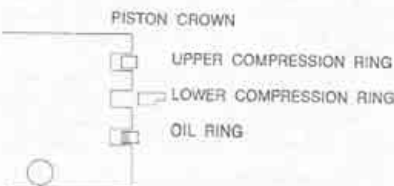

Correct installation of stepped compression ring

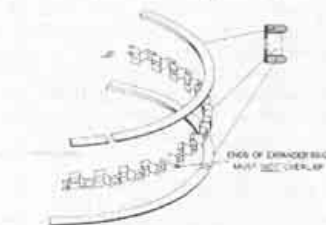

Three-piece oil ring installation

3. Stagger the ring end-gaps around the piston.

4. Fit the pistons to the rods, using new circlips. The rounded edge of the circlip, where applicable, must face the piston.

Be sure the pistons are correctly fitted. 850 models have the crown stamped "RH" or "LH" and the "EX" mark must face the front of the engine.



Piston installation (750)

750 Models have valve cut-outs. The exhaust valve cut-out is closer to the edge of the piston and must be positioned towards the front of the engine.

ASSEMBLY

1. Install the cylinders. Tighten the bolts or nuts in a cross pattern until the correct torque is reached.

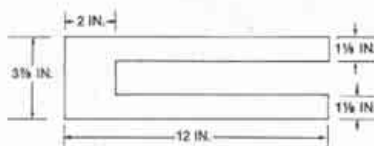

Piston stand dimensions

On 750 models, 20 ft lbs for the two small nuts and 25 ft lbs for the others.

On 850 models, 30 ft lbs for allen bolts, 25 ft lbs for the front nut, and 20 ft lbs for the others.

2. Place the pistons at top dead center.

3. Place the four pushrods up into the head as far as they will go, as described in "Removal." The longer pushrods are to be positioned closest to the center of the head.

4. Carefully position the head over the barrels, so that the pushrods will drop directly into the tunnels, and take care that the three studs in the head do not damage the gasket.

5. Let the pushrods drop into their tunnels and make sure that they are properly fitted into the tappet cups.

6. Lower the head onto the barrels. The upper end of the pushrods must now fit with their respective rocker arm ball ends.

CAUTION: On Scrambler models for which the rocker arm had to be removed before taking the head out of the frame, this rocker arm must now be replaced. This is an operation requiring extreme caution lest the washer or spring drop out of reach. It is probably wise to replace the rocker arm now, before bolting down the head.

7. Support the head about 1/4 in. off of the barrels. Those two long cylinder sleeve nuts, which are found beneath the exhaust ports, can be used to support the head in this position.

8. Looking through the exhaust and intake rocker boxes, fit each pushrod with the proper ball end. A short piece of wire with a hook at one end can be used to move the pushrods to accomplish this.

9. When you think you have engaged all of the pushrods, remove the nuts which support the head. Check again. Be absolutely certain all of the pushrods are engaged before proceeding further.

10. Tighten all of the cylinder head bolts and nuts in the order shown. Tightening should be done in increments of 5 ft lbs.

11. Adjust rocker clearances as described in "Tune-Up."

12. The remainder of the assembly procedure is the reverse of that given for disassembly. Before starting, squirt some clean engine oil into the pushrod tun-



Cylinder head tightening sequence

nels, the rocker spindles, and the valve stems.

13. After the engine has been warmed up, allow it to cool and retorquing the head bolts and nuts. After the engine is cold, readjust the valves.

Clutch and Primary Drive

COMMANDO 1974 AND EARLIER

Disassembly

1. Remove the left-side footpeg and place a pan beneath the primary chaincase to catch the oil; take off the chaincase fixing bolt and pull off the cover.

2. Disconnect the alternator wires at the snap connectors. Unbolt the stator and pull the wires (carefully) through the inner chaincase half.

3. Remove the sleeve nut and the lockwasher which secures the alternator rotor to the crankshaft. Remove the rotor, using a gear puller if needed, and take out the woodruff key. Use a pair of pliers if it is tight.

4. The triplex chain is endless variety and, therefore, the engine and clutch sprockets and the chain must be removed simultaneously.

CAUTION: The clutch can only be removed with the aid of a special tool and it is dangerous to attempt to do so without it.

5. Loosen the clutch adjuster nut and remove the adjuster screw.

6. With the special clutch compressor tool (Part No. 06-0999), screw the center bolt of the tool into the diaphragm spring center. Tighten the nut on the tool's center bolt until the diaphragm spring is free to turn in the clutch sprocket. Stop at this point.

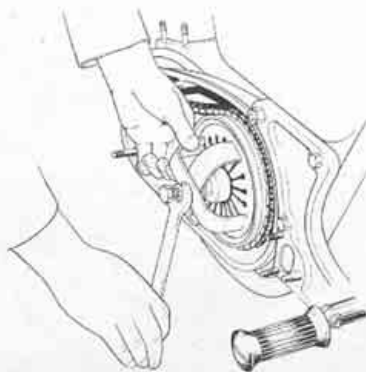

Using special tool to compress diaphragm spring

7. Remove the large circlip which retains the diaphragm spring (there is a groove provided to make removal easier) and take away the spring and the tool together.

8. Remove the nut and washer which secures the clutch hub to the transmission mainshaft; it is necessary to stop the clutch from turning so that this nut can be broken loose. Use the clutch hub tool (Part No. 06-1015) or a suitable substitute. Alternately, put the transmission in gear and apply the rear brake to remove the clutch nut.

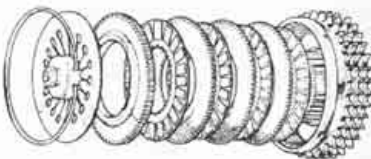

Commando clutch assembly

9. Remove the engine sprocket from its tapered shaft. It is press-fit here and must be removed from the taper with a special tool. The procedure here is to attach the extractor to the sprocket and, after tightening the center bolt, rap it once with a hammer. This should break the sprocket off the shaft. If necessary, a small gear puller can be used instead.

10. The engine sprocket, chain, and clutch hub sprocket can now be taken away. There may be shims behind the clutch hub sprocket. These are used to adjust the true running of the primary chain and should be reassembled in their proper place.

If necessary, a special tool is available which screws into the center of the clutch to aid in removing it from its shaft. It might not be necessary if the clutch has been removed before.

After the assembly has been taken out of the chaincase, remove the engine sprocket woodruff key.

Inspection

1. Maximum allowable plate warpage is 0.012 in. (0.3 mm).

2. Although it operates in the primary chaincase which contains oil to lubricate the chain, this clutch is the "dry" type. The 750's friction plates must have dispersal grooves to get rid of any excess oil which accumulates on them. It may be necessary to cut these grooves if the plate does not have them. Four dispersal grooves spaced 90° apart should be sufficient. On the other side of the friction plate, cut four more grooves offset 45° in relation to the first set and also spaced at 90°.

The plates may have a single groove on each side which is elliptical in reference to the center of the plate.

3. The clutch hub runs on a bearing fitted into the clutch sprocket and located with circlips. To remove the clutch bearing:

- Take out the small circlip which holds the clutch hub with sleeve extension;
- Press out the clutch hub;
- Take out the circlip bearing (the large one);

Norton



Commando clutch bearing assembly

d. Press out the bearing from the inside of the clutch sprocket. Check the bearing for smooth, effortless rotation. If the bearing is halting or rough, or if there is any play between the outer and inner races, replace it.

Assembly

1. Assembly is the reverse of disassembly.
2. First install the clutch and engine sprockets without the primary chain. Place a straightedge across the sprockets to check that the chain line is true. If adjustment is necessary, add or remove shims behind the clutch sprocket.
3. When installing the assembly, tighten the clutch nut to 70 ft lbs, and the engine (rotor) nut to 80 ft lbs.
4. After installing the alternator stator, check that the gap between the stator and the rotor is even all the way around. The gap should be about 0.010 in. If the rotor and stator touch at any point, or if the gap is obviously not equal at all points, loosen the stator mounts and try to move it to even out the gap. If this is not possible, check for bent mounting studs.

COMMANDO 1975 AND LATER

Disassembly

1. Disconnect the electric starter terminal. Engage First gear. Remove the two bolts from the left footpeg mounting flange.
2. Remove the primary chaincase drain bolt to drain off the oil.
3. Place a large pan beneath the chaincase to catch any residual oil when the cover is removed. Remove the primary chaincase screws and the electric starter locating screw, and remove the cover. Tap the cover with a plastic mallet or the like to free it if stuck.
4. Remove the gearshift cross-shaft.
5. Apply the rear brake and remove the alternator rotor nut and the fan disc washer behind it.
6. Remove the alternator stator after disconnecting the leads, and remove the three stator securing nuts.
7. Remove the alternator rotor. The rotor is keyed to the crankshaft. If it resists, use a small gear puller or pry it off with two screwdrivers. Remove the woodruff key and any shims fitted.
8. Remove the alternator stator mounting plate.
9. Remove the reduction gear assembly, sleeve, and washer.
10. Remove the starter intermediate gear shaft with the overload device.
11. Remove the small primary chain tensioner nut; then the two remaining nuts, and remove the tensioner. The ten-

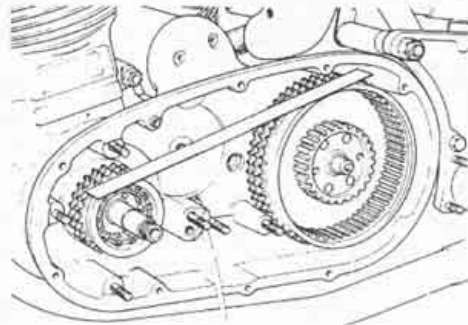

Checking alignment of sprocket and clutch

sioner plungers must remain in their original bores so mark them before removal.

12. Loosen the clutch adjuster nut and remove the adjuster.
13. With the special clutch compressor tool (Part No. 06-0999), screw the center bolt of the tool into the diaphragm spring center. Tighten the nut on the tool's center bolt until the diaphragm spring is free to turn in the clutch.
14. Remove the large circlip which retains the spring, and take away the spring and tool together.
15. Remove the nut and washer which secures the clutch hub to the transmission mainshaft. It is necessary to stop the clutch from turning so that this nut can be broken loose. Use the clutch hub tool

(Part No. 06-1015). Alternately, apply the rear brake after putting the transmission in gear to remove the clutch nut.

16. Break the engine sprocket off its shaft. The shaft is tapered, and the sprocket must be removed with the special extractor. A small gear puller can also be used.
17. The sprocket, chain, and clutch assembly can now be removed. There may be shims behind the clutch. These are used to adjust the true running of the primary chain and must be reinstalled. If any new components are fitted, the chain line should be checked and shims added or subtracted as necessary.

Inspection

Refer to "Commando 1974 and Earlier" for inspection procedures.

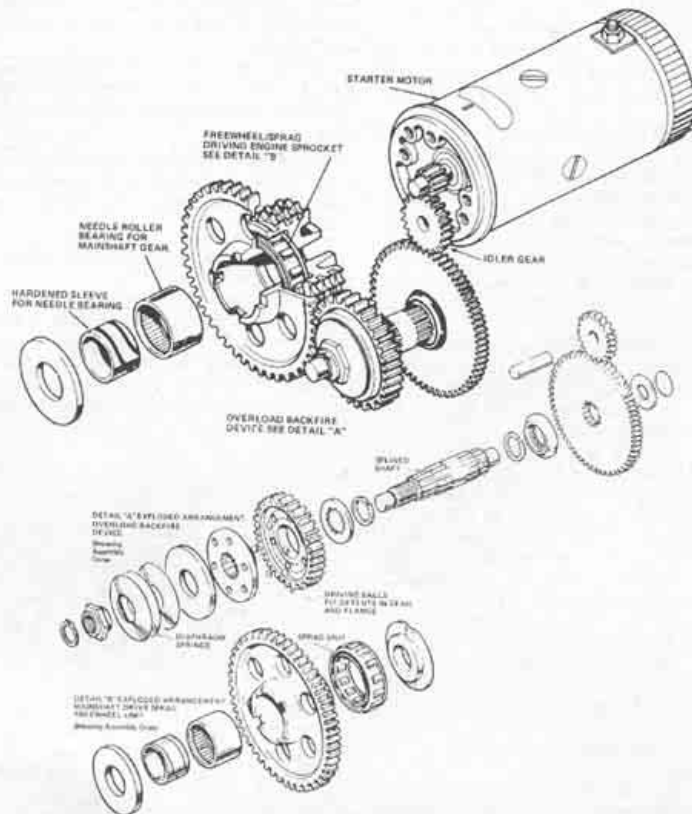

Electric starter drive and reduction assembly

Assembly

1. If the inner chaincase has been removed it must be refitted so that the transmission shaft is perpendicular to the oil seal. Check alignment before bolting up the case.

2. Fit the clutch shaft circlip and the spacer, with the recessed end toward the transmission. Install any spacers which were fitted, and install the engine sprocket and clutch hub and check alignment as outlined under "Commando 1974 and Earlier."

3. After checking chain alignment, fit the large starter gear, then the clutch, sprocket, and primary chain together. Be sure the engine sprocket is pushed onto its shaft as far as possible.

4. Tighten the clutch nut to 70 ft lbs.

5. Install the clutch plates, first fitting a friction plate, then a steel plate, and alternating until fitting the last (iron) plate. Fit the diaphragm spring with the tool attached, and the large circlip. Remove the clutch tool.

6. Fit the clutch adjuster and locknut.

7. Install the thrust collar into the engine sprocket recess with the small end facing outward.

8. Install the sleeve onto the crankshaft. Fit the starter assembly into the sprocket.

9. Install the large starter gear and bearing over the hardened sleeve and insert it into the assembly.

10. Install the chain tensioner. If the plungers have been removed from their bores, add some oil before refitting. Tighten the nuts gradually, torquing the $\frac{1}{16}$ in. nuts to 12 ft lbs, and the $\frac{1}{4}$ in. nuts to 5 ft lbs. Use thread locking compound on these nuts. Do not overtighten.

11. Fit the overload device.

12. The remainder of the procedure is the reverse of disassembly. Rotor nut torque is 80 ft lbs. Check that the air gap between the rotor and stator is about 0.010 in. all the way around.

PRE-COMMANDO

Disassembly

1. Remove the left-side footpeg if necessary.

2. Disconnect the alternator leads at the snap-connector.

3. Remove the large hex nut which secures the chaincase cover (or the screws around the cover on Scramblers). Pull off the chaincase, allowing the oil to drip into a suitable pan.

4. On some models, the alternator stator comes off with the chaincase cover. If not, remove it at this time.

5. Remove the rotor nut. Use a small gear puller, if necessary, to remove the rotor. Take the woodruff key out of the crankshaft.

6. Remove the clutch pressure plate by unscrewing the three spring adjustment nuts. Each nut has two small tabs, on the face which bears against the spring, to prevent loosening in operation. It is possible to place a thin knife blade between the spring and the nut to prevent the tabs from being sheared off upon removal. Otherwise, the nuts should be replaced upon reassembly.

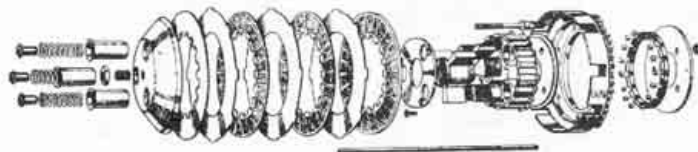

Pre-Commando clutch assembly

7. Remove the clutch springs, cups, and pressure plate. Remove the steel and friction plates.

8. Remove the nut and washer which secure the clutch assembly to the transmission mainshaft.

NOTE: It is necessary to stop the clutch from turning so that this nut can be removed. You can make a simple, though effective, tool to do this. This consists of a standard clutch plain metal plate and a standard friction plate. Bolting the two together takes the place of spring pressure and will make removal of the center nut much easier.

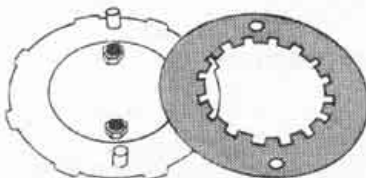

Tool to stop clutch from turning (pre-Commando)

Alternately, the nut can be removed by engaging the transmission, and applying the rear brake. If the engine is out of the frame, an old length of chain wrapped around the sprocket with one end secured in a vise will serve the same purpose.

9. Disconnect the master link of the primary chain and remove the chain.

10. Using the special tool, if necessary, remove the clutch assembly. This tool screws into the center of the clutch and pulls it off the shaft. It may not be necessary to use the tool if the clutch has been removed before.

11. Using a small gear puller, take the engine sprocket off of the tapered portion of the crankshaft. Remove the woodruff key.

Inspection

1. Maximum allowable plate warpage is 0.012 in. (0.3 mm).

2. Friction plates which have become oil-impregnated through long service should be replaced, although it may be possible to salvage them for awhile by dusting with an oil-absorbing compound, and washing in a mild solvent.

3. The clutch hub studs, if damaged or bent, can be removed by removing the nuts on the back of the clutch hub. The nuts are peened for security, and should be replaced rather than reused. Be sure to peen the nuts after tightening them securely.

4. The clutch has rubber shock absorbers in the hub to prevent "snatching"

and the damage it might cause. To inspect them, remove the three countersunk retaining screws from the front of the clutch hub and pry off the steel plate. The rubber blocks will come out of the hub easily if they are worn.

Assembly

Assembly is basically the reverse of the disassembly procedure. Note the following points:

1. Be sure to install the chain masterlink spring clip so that the closed end faces the direction of chain rotation.

2. When assembling the clutch, first fit the housing and hub. Install the engine sprocket onto the crankshaft with the boss outward. Fit the primary chain.

3. Install the clutch plates, noting that the single-sided friction plate is installed last with the steel side outward.

4. Replace the spring cups and springs; the cups have a tab to fit a slot on the pressure plate.

5. Screw down the adjusting nut with a fork-like tool. These should be flush with the spring cups after assembly.

6. Replace the rotor and tighten the rotor nut very firmly. It is advisable to secure this nut with thread locking compound.

7. Bolt on the alternator, run the leads through the inner chaincase half, and reconnect them.

8. Kick the engine over several times while watching the rotor, to be sure that it does not contact the alternator stator at any point. An even gap all around the rotor is preferred and washers may be placed behind the stator to accomplish this.

A spacer, about 0.010 in. thick, can be placed around the rotor and used as a guide while tightening the stator nuts.

9. Work the handlebar clutch lever several times and notice the operation of the clutch. The pressure plate must remain parallel to the other plates when it disengages. If it does not (you will notice it coming off the assembly at an angle), adjust the clutch springs.

10. Adjust the clutch as outlined in "Maintenance."

Timing Case

All of the valve and ignition timing gear on the Norton 750 and 850 is contained in the case on the right-side of the crankcase. The oil pump as well as several important oil seals and junctions for the lubrication system are found here also.

The timing is accomplished by means of a small pinion which is fitted to the end of the crankshaft and drives an inter-

Norton

mediate gear and sprocket. This sprocket drives the camshaft by means of a short, single-row chain. The oil pump drive gear is also located on the crankshaft.

Commando engines after No. 131257 have the ignition points operating at the right end of the camshaft. Prior to this model, Commandos had the points located in a canister behind the cylinder barrels. The points were timed by another chain from the intermediate sprocket to the distributor sprocket which was secured to its shaft by a pin.

Most other Nortons, including the Atlas and G15CS, were equipped with the Lucas K2F magneto. This unit, too, was located behind the barrels and it was also driven by chain from the intermediate sprocket. The automatic spark advance mechanism for the magneto was integrated with the magneto sprocket and they were secured to the magneto's tapered shaft with a self-locking bolt.

TIMING COVER

Removal

To remove the timing cover, follow the procedure outlined below, with attention to variations for particular models.

1. Disconnect the tachometer drive if it is mounted on the outside of the timing cover.
2. Remove the ignition points cover (after engine No. 131257).
3. Remove the rocker oil feed pipe banjo at the rear of the timing cover. If the engine has been recently run, a little oil may dribble out.

AFTER ENGINE NO. 131257:

4. Remove the ignition point base plate which is secured by two screws, also the wires. It may be helpful to mark the location of the base plate before removal, so that it can be reinstalled without the necessity of resetting the timing.
5. Remove the automatic timing advance center bolt.
6. Screw a withdrawal bolt (Part No. 06-0934) into the center of the advance mechanism to pull it off of the camshaft. Slide hammer 06-4298 can also be used.

ALL MODELS:

7. Place a can beneath the cover to catch the oil. Take out the timing cover screws. There are twelve of them and they are of three different lengths, so note their positions.
8. Pull off the timing cover. If difficulty is encountered, tap around the cover very lightly with a rubber mallet until the cover can be separated. Often a commercial brand of penetrating fluid can be used to break the seal.
- Note the oil seal plunger and spring fitted to late 850 models.
9. Oil will dribble out of the drilling in the crankcase at the left (as you look at it) of the timing case. Use one of the cover screws to block off the flow of oil.

TIMING ASSEMBLY

Removal

If the sprockets and chain are to be removed, mark both with paint before removal.



Removing the advance mechanism

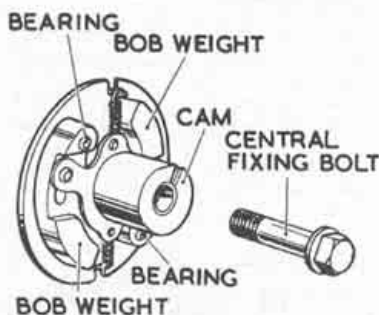

Timing advance mechanism

1. Remove the oil pump. It is secured by two nuts. Make sure that the pump has the conical oil seal fitted on the nipple of the pump body. Sometimes this seal comes away with the timing cover, so check there if it is missing. Note the presence of any shims behind the seal.
2. Remove the oil pump drive gear. This has a LEFT-HAND thread onto the crankshaft.
3. Remove the camshaft chain adjuster. This assembly consists of two

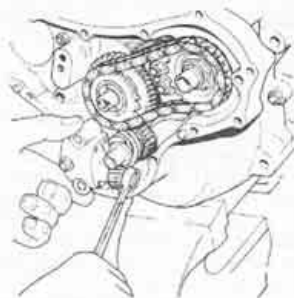

Removing the oil pump



Removing the camshaft sprocket nut

plain metal plates of varying thickness and a metal slipper which bears on the cam chain and it is fastened by two nuts. The thin metal plate goes on the engine side of the slipper.

4. Remove the nut which secures the camshaft sprocket. The sprocket can be taken off with a gear puller or with the extractor tool (Part No. EST12). The cam sprocket cannot be removed at this point on models with a separate ignition timing chain. For these models:

5. Loosen the magneto sprocket bolt and make sure that the automatic advance mechanism can be removed from

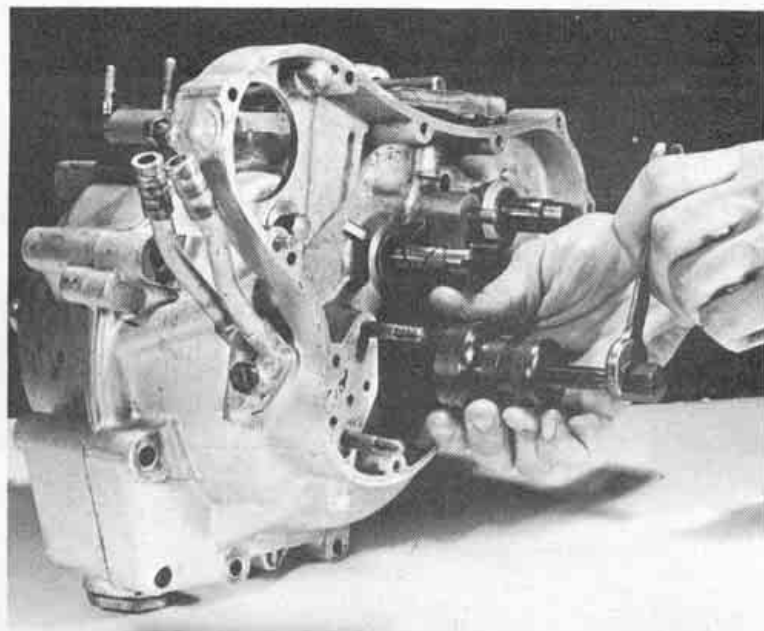

Removing the timing pinion

the magneto shaft or, on capacitor ignition models, drive out the pin passing through the distributor sprocket and shaft.

6. Remove the intermediate sprocket, cam sprocket, and ignition sprocket (if applicable) together. Pinch the chain or chains in the center of their runs to ensure that the sprockets do not change their position on the chain relative to the intermediate sprocket. Remove the thrust washer behind the intermediate sprocket if fitted. Take the woodruff key off of the camshaft.

7. Remove the small timing pinion from the crankshaft. This necessitates the use of the special extractor (Part No. ET2003).

Remove the pinion key, the triangular washer, and the metal oil seal from the crankshaft.

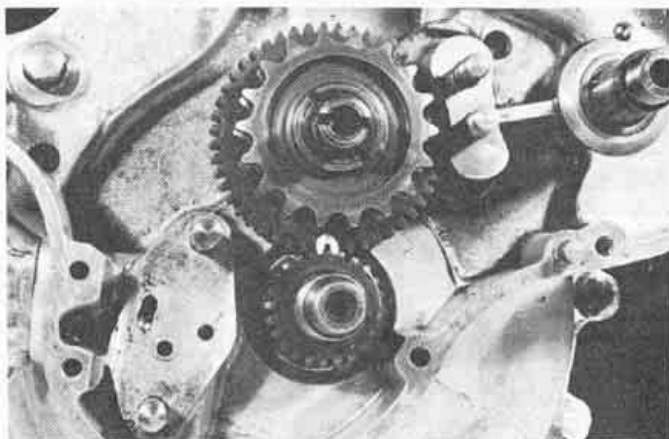

Timing pinion and intermediate sprocket marks aligned

Inspection

1. Check for cracks in the cam chain adjuster slipper. This can occur if the chain had been overtight. Allow for proper play upon reassembly.

2. The magneto or points canister have a small amount of movement on their mountings to adjust the chain tension. Once this movement has been used up, the chain must be replaced.

Installation

1. Replace the metal oil seal, the triangular washer, and the pinion key on the crankshaft.

2. Replace the pinion. Be sure the bevelled edge faces outward, there is a timing "dot" on the outer side of the pinion also.

3. Replace the thrust washer on the intermediate shaft if fitted.

4. Rotate the crankshaft until the small timing dot on the timing pinion is at 12 o'clock.

5. Take the cam timing chain with the intermediate sprocket and cam sprocket, and the ignition timing chain and sprocket if applicable, and position the intermediate gear so that its timing dot aligns with that on the timing pinion.

6. Also fit the cam sprocket on the cam. It is keyed.

7. If the timing has been preserved—fine, but if you are not entirely sure, there is an easy check. There are timing dots on both the intermediate sprocket and the cam sprocket. When the intermediate sprocket is in the correct position, there should be SIX outer plates of the drive chain between the two dots.

8. Replace the distributor or magneto sprocket. If a magneto is fitted, do not tighten the fixing bolt all the way, as the timing must be reset.

9. Stop the engine from turning by placing the transmission in gear or, if the engine is disassembled, place a steel bar through the connecting rod small ends and the bearing on the top of the crankcase. Tighten the camshaft sprocket nut.

10. Replace the oil pump drive gear on the crankshaft (left-hand thread) and tighten it also. The nut should be very tight. Some thread locking compound here is a good idea.

11. Apply a thin coat of gasket com-

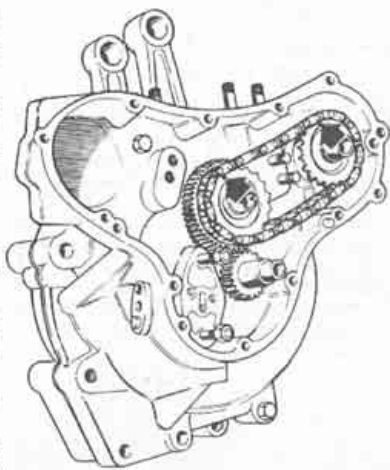

Cam chain correctly timed (six chain plates between the dots on the sprockets)

pound on the face of the oil pump unless a gasket is fitted, and replace the pump on its studs. Tighten the two nuts evenly and torque both to 15 ft lbs.

12. Replace the thin metal plate on the cam chain tensioner with the longest portion from the bolt hole downward.

13. Replace the tensioner slipper itself and, finally, the thick plate. Replace, but do not tighten, the two nuts on the tensioner.

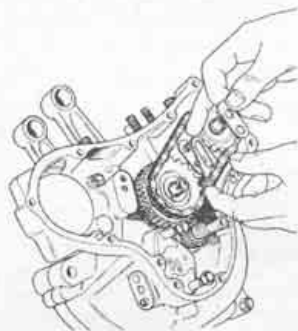

Installing the cam chain tensioner

14. The cam chain tension must now be adjusted. A cut-away timing cover is handy to have for the adjustment of the chain, since it supports the intermediate sprocket spindle and allows a more accurate setting of the chain slack to be made.

1975 and later models have an inspection hole in the timing cover for this purpose.

The tensioner should be adjusted to bear against the lower chain run until there is $\frac{3}{16}$ in. play measured in the middle of the upper chain run.

15. If an ignition chain is fitted, this can be adjusted (also to $\frac{3}{16}$ in. play in the middle of the upper run) by loosening the two nuts and one bolt which secure the distributor or magneto, and pivoting the unit until the desired tension is reached. A screwdriver can be used to pry behind the unit, as there is a shoulder provided on the case for this.

CAUTION: Overtightening of the magneto chain can cause binding of the automatic spark advance mechanism. Therefore, ensure that the chain slack is correct and that the advance mechanism moves freely after the timing is adjusted.

TIMING COVER OIL SEALS

1. To remove the large seal, take out the circlip which secures it and pry the seal out.

2. When replacing the seal, gently heat the cover with a propane torch or suitable replacement and fit the seal with the metal face outward (toward you as you install it).

3. The smaller seal is present on machines after engine No. 131257 and is intended to prevent oil from getting into the points compartment. It fits directly over the camshaft. Pry out the seal with a sharp pointed tool.

4. Warm the cover as before and press the seal into position, metal backing facing you as you install it.

5. The timing cover also has the oil pressure relief valve which is located just above the rocker oil feed pipe junction. The relief valve is spring-loaded to operate at a predetermined pressure and, therefore, needs no attention. The valve does have a wire filter screen fitted which

Norton

might be checked and cleaned if necessary.

TIMING COVER

Installation

1. Remove all traces of old gasket and gasket compound from the mating surfaces. The timing cover can be worked on an appropriate surface (such as a sheet of emery cloth placed on a piece of glass) to remove any surface irregularities, scratches, etc.

NOTE: Early model Nortons had a rather thin paper gasket for the timing cover which was effective only if the mating surfaces were in very good condition. The Commando has a thicker gasket which may be used to advantage on earlier models also. The only difference between this and the earlier gasket (aside from the thickness and composition of the material) is an extra hole for the points wires. This is not needed for early models and can be removed.

2. Models fitted with the ignition points at the camshaft must use a guide bush (Part No. 06-1359) over the cam to prevent damage to the oil seal in the timing cover. The threaded portion of the bush is screwed on to the camshaft by hand, as far as possible. Add a little oil to the outside of the bush to make assembly easier.

3. Check the condition and efficiency of the conical seal on the oil pump. If it is deformed, replace it. It should be able to push the timing cover away from the case about 0.010 in. when fitted. If it does not, replace it, or use shim washers behind the seal.

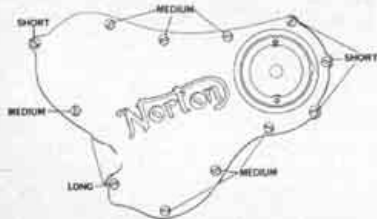

Timing cover screw locations

If the thicker gasket has been fitted to early models, shim washers may be necessary.

4. Refit the timing cover, screw in the 12 cover screws, and tighten them evenly and in a diagonal pattern.

5. Reconnect the rocker oil feedpipe banjo.

6. Reconnect the tachometer drive cable if applicable.

For Commando models after engine No. 131257:

7. Remove the inspection cap on the primary chaincase to expose the indicator plate.

8. Position the engine so that the timing mark on the rotor registers 28° on the indicator plate (each mark equals two degrees).

9. Insert the timing advance mechanism and position it so that the rivets for the bob weights are in line with the two

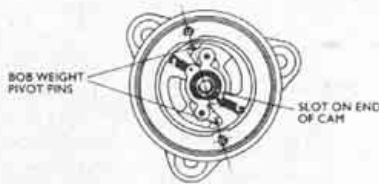

Timing advance mechanism positioned for installation

screw holes for the point cover. The slot (not the slash mark) in the breaker cam should now be about 9 o'clock.

10. Replace the ignition point base assembly. The yellow and black lead is for the drive side cylinder (left point set).

11. Adjust the timing.

Bottom End

Disassembly

1. Remove the engine from the frame. Remove the primary drive and clutch, cylinder head and cylinders, timing cover and timing gear, etc.

2. Unbolt the crankcase studs and remove the screw(s) at the bottom of the cases.

3. Tap against the inside of the left-side crankcase half with a plastic mallet or wooden block to separate the cases. If difficulty is encountered, gently heat the drive side bearing boss. This should only be necessary on relatively new engines.

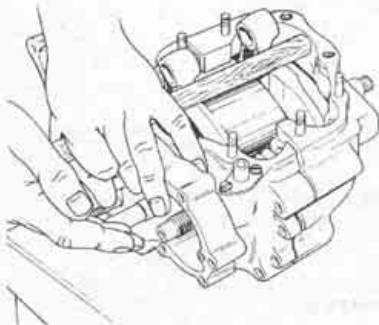

Separating the crankcase halves

4. Take out the camshaft, and the crankcase breather plate and spring, if fitted.

5. Heat the timing side bearing boss, holding the right-side crankcase half, and tap on the timing end of the crankshaft with a plastic mallet to free it.

NOTE: It is a good idea to use a sleeve over the crankshaft end to avoid damage to it or to the oil pump worm gear threads.

6. Bearings can be removed from the crank by prying them off.

7. To remove bearing races from the crankcases, heat the case in an oven (not to exceed 200° C), then drop the case onto a wooden block from about a 6 in. height. If removal is difficult, the bearing race can be cooled, after the case is heated, either with a damp rag, or by running an ice cube around the race.

8. The drive side oil seal can be punched out after removing the bearing race. Late models are equipped with a circlip which must be removed before the oil seal.

Assembly

1. Assembly is the reverse of disassembly.

2. On models with a cam-timed crankcase breather, refusal of the case halves to mate is sometimes due to the engaging dogs on the breather plate not properly engaging the camshaft.

3. On models with a roller bearing on the timing side, insure proper lubrication by pouring clean engine oil into the intake rocker box after engine assembly is completed. This oil will drain into the timing case, and then to the bearings.

4. Be sure that all bearings and bushings are well lubricated before reassembling the rest of the engine.

CONNECTING RODS AND JOURNALS

Removal and Installation

1. To remove the rods, remove the rod bolt nuts and pull the rod off the journal with a sharp jerk.

2. Be sure to keep each rod with its own cap. Rods and caps are machined together, and it is essential that the rod-and-cap assemblies be kept separate. In addition, note that there is a slash mark on each which indicates the correct cap position.



Connecting rod assembly

3. Rod journals must be within 0.001 in. of perfectly round. Minor scoring can be removed with fine emery tape, but if the journal is oval, or heavily scored, it must be reground.

If the crankshaft is reground, be sure that a 0.090 in. radius is restored on the journal shoulder.

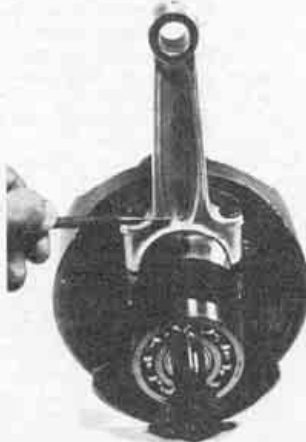

The oil hole at the base of the rods must face outwards

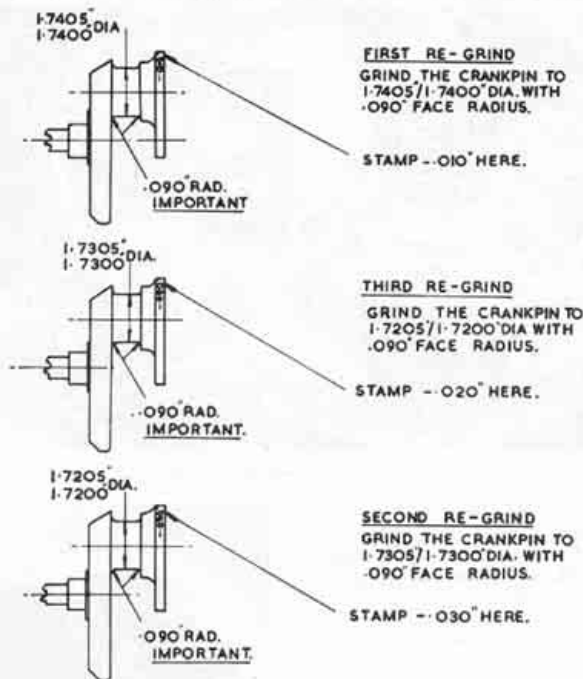

Crank re-grinding dimensions

4. Undersized big end bearings are available in four sizes: 0.010 in., 0.020 in., 0.030 in., and 0.040 in.

The size of the replacement bearing should be stamped on the end cheek.

5. There is no bush at the rod small end, the piston pin riding directly on the rod itself. Small end diameter should not exceed 0.6868 in.

6. Assembly is the reverse of removal. Be sure that the mark on each cap aligns with that of its own connecting rod. Install the rods with the oil hole at the lower end pointing AWAY FROM the center of the crankshaft.

7. New rod bolt nuts must be used, and the use of new bolts is recommended as well. Tighten these nuts to 25 ft lbs.

8. Be sure the big end bearings are well lubricated before assembly.

CRANKSHAFT

Disassembly and Assembly

The crankshaft is a three-piece unit consisting of a center flywheel and two end cheeks which incorporate the rod journals. The crank is bolted together.

1. Mark the positions of the cheeks and the flywheel to eliminate the chance of accidental interchange.

2. Straighten the lock tabs, if applicable, then remove the crankshaft nuts and separate the pieces.

3. Clean out the sludge trap machined into the flywheel.

4. Before assembly, be certain that the mating surfaces are absolutely free of foreign matter.

5. Nuts are torqued to 35 ft lbs on 750s and 30 ft lbs on 850s. Tighten in a cross pattern. Turn up the locking tabs, if fitted. If not,peen the nuts with a punch to lock them in position.

CAMSHAFT

1. After splitting the cases, make the usual inspections of the cam and cam bushes. The bushes must be free of wear or score marks. If replacement is necessary, heat the cases and drive the bushes out. When installing new bushes, align the oil hole in the bush with that in the crankcase.

New bushes must be reamed to size after installation.

Important: Either the cam bushes or the cam itself must be fitted with oil distribution grooves or damage will result. If the camshaft does not have oil grooves, obtain and install grooved bushes.

Transmission

The transmission is basically the same on all models covered here, the major change being the introduction of the left-hand shift for 1975 and later models.

GEARBOX REMOVAL AND INSTALLATION

1. Removal and replacement of all gearbox internal parts with the exception

of the layshaft left-side bearing is possible without removing the gearbox shell from the frame. If removal of the entire unit is desired, the engine must be removed on 1969 and earlier models.

2. On 1970 and later units, remove the clutch and primary drive assembly. Remove the rear wheel. Disconnect the chain.

3. Remove the three rear crankcase-to-engine plate bolts or studs.

4. Support the motorcycle on a large block of wood or a crate, remove the rear wheel and the center stand.

5. Remove the top and bottom mounting bolt and stud. Turn the gearbox counterclockwise as far as possible. Push the rear engine mounting towards the rear of the motorcycle, until the cutaway at the bottom right is clear of the crankcase, and continue rotating the gearbox until it can be removed.

In some cases it may be necessary to remove the front main mounting bolt for extra clearance.

6. Installation is the reverse of the above.

OUTER COVER

Disassembly

1. Take off the clutch lever inspection cap on the outer cover and disconnect the clutch cable by prying up the lever and slipping out the nipple. Unscrew the cable adjuster from the case. Drain the transmission oil.

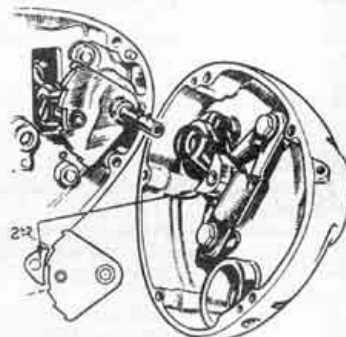

Gearbox outer cover assembly

2. Remove the kick-starter crank bolt and remove the crank. It might be necessary to use a claw-type puller to get the crank off the splined shaft.

3. Remove the right footpeg.

4. Remove the bolt for the gearshift lever, but leave the lever in place.

5. Remove the five screws which secure the outer cover.

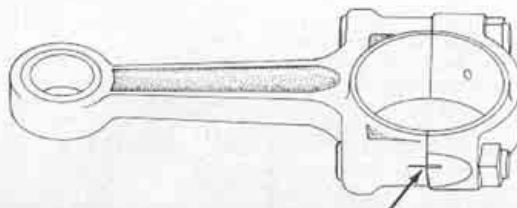

Caps must be installed so that the slash mark on rod and cap align

Norton

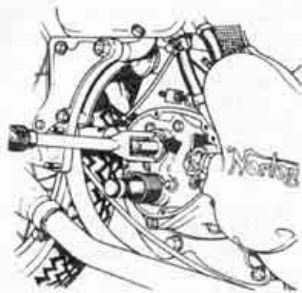

Removing the clutch operating lever

6. Carefully pull off the cover, using the gearshift lever to assist you.
7. Remove the pawl spring.
8. Disengage the shifter return spring legs from the pawl pin, and withdraw the pawl carrier, tapping it if necessary.
9. Remove the shifter stop plate (two bolts), and remove the return spring.

Inspection

1. Check the shifter pawl for unusual wear.
2. The outer cover has two rubber O-rings which act as oil seals. The larger of the two is found on the kick-starter shaft behind a steel bush. The bush may be removed by heating the case and driving it out from the outside after first prying out the O-ring.
3. The smaller O-ring is for the gear shifter shaft. To remove the bush here, heat the cover, gently screw a coarse threaded tap into the bush, and pull it out.
4. Remove any traces of old gasket material from the outer cover mating surface and check the condition of the surface. All abrasions, scratches, etc. should be removed with an oil stone.

Assembly

1. Assembly is the reverse of the previous procedure.
2. When refitting the pawl spring, notice that the cranked leg of the spring will be in the lowest position, the straight leg in the higher.
3. Assure that the pawl concave side is facing the gearshift spindle so that it can remesh with the ratchet plate.
4. Put some clean oil on the kick-starter shaft to avoid bruising the O-ring on reassembly.

INNER COVER

Disassembly

1. Remove the ratchet plate with spindle.
2. Unbolt the clutch operating lever and remove it and its roller from the shaft.
3. Mark the position of the slot in the clutch operating lever shaft on the inner cover so that the shaft can be reassembled in the correct position to give the clutch cable a straight pull. On recent models, the assembly is already marked.
4. Unscrew the lockring on the clutch lever shaft and remove the lockring, the shaft, and the ball.
5. Remove the mainshaft nut which will be exposed after removing the shaft.

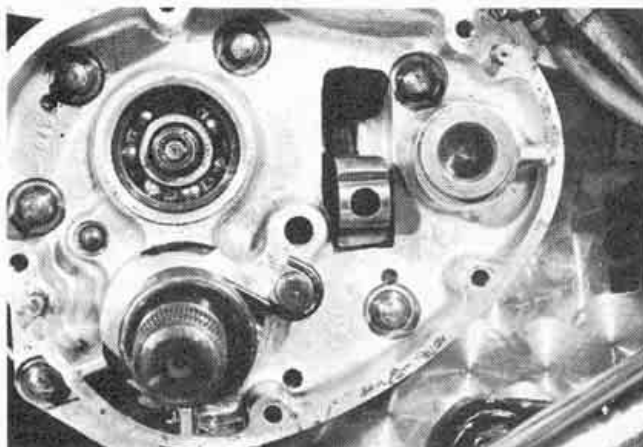

Inner cover ready for removal

6. Remove the seven nuts which secure the inner cover to the gearbox shell and pull off the inner cover, tapping lightly at the front end if necessary.
7. Take the kick-starter return spring out of the hole in the kick-starter shaft.
8. Pull the kick-starter shaft out of its bush from the inside of the cover.

Inspection

1. Check the mating surfaces of the inner cover for scratches, abrasions, or knicks. If present, these may be removed with emery cloth. In addition, place the cover on a flat surface, such as a piece of glass, and make sure that it is flat.
2. Check the mainshaft bearing for excessive play, roughness or binding in rotation, or obvious marks of wear. Replace the bearing if necessary by heating the case gently and driving out the bearing.
3. If the kick-starter bush is worn, it can also be removed after heating the case. After the new bush is driven in, it should be reamed to 0.6875-0.6865 in.
4. Check the condition of the kick-starter pawl very carefully. Be sure that the pawl shows no signs of wear or chipping along the edge. The pawl is easily replaced by removing the pin. If this is done, watch for the plunger or spring.
5. Examine the kick-starter stop-piece and the pawl cam which are riveted to the inner cover. Check for looseness on the rivets and re-rivet the stop-piece if necessary.

Assembly

1. Assemble the inner cover in the reverse of the disassembly procedure. Be certain that the clutch operating lever shaft is correctly aligned to give the cable a straight pull.
2. Be sure that the mating surfaces are clean and in good condition. Refit a new gasket.
3. Tighten the inner cover nuts evenly and in a cross pattern to 12 ft lbs. Fit and tighten the mainshaft nut.

GEAR CLUSTER

Disassembly

1. Proceed with the disassembly procedures outlined above. Removing the

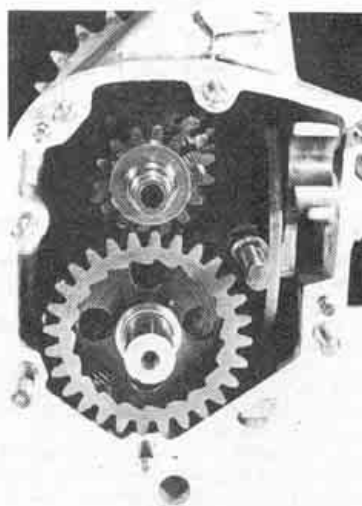

Gear cluster and shifter assembled

inner cover will expose the gear assemblies on the two shafts. The upper shaft is the mainshaft and the lower is the countershaft (or layshaft).

2. Remove the low gear pinion on the mainshaft. Note that the boss on this gear faces outward.
3. Unscrew the shifter fork spindle and remove it.
4. Remove the shifter forks.
5. Remove the clutch pushrod from the mainshaft.
6. If the clutch has been removed, remove the mainshaft and the gears on it. The sleeve gear will remain in place.
7. Take out the layshaft and the layshaft gears.
8. If disassembly is required past this point, it is necessary to remove the primary chaincase, etc., to gain access to the transmission sprocket.
9. Remove the screw which secures the lock plate on the transmission sprocket.
10. Remove the transmission sprocket nut, which has a LEFT-HAND thread, and remove the sprocket from the shaft.
11. Remove the sleeve gear from the bearing.

Norton

Engine and Transmission Specifications

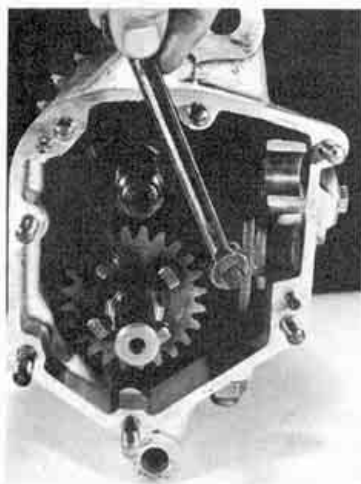

Removing the shift fork spindle

12. Remove the dome nut at the bottom of the transmission case and take out the plunger and spring. Remove the neutral switch, if fitted.

13. Remove the bolt fixing the quadrant and the bolt which secures the camplate and remove these components.

14. To remove the layshaft bearing, it is necessary to remove the case. Heat it in an oven (do not exceed 200° C), then tap the case with a plastic mallet to knock out the bearing.

15. The mainshaft bearing can be removed after prying out the oil seal and again heating the case, driving out the bearing with a suitable drift.

Inspection

1. Check the condition of the mainshaft and layshaft bearings. All bearings should rotate with little friction and should be smooth throughout.

2. The bushes for the camplate and quadrant mounting bolts should be checked. Wear would make shifting difficult. The bushes may be removed by heating the case and tapping them out.

3. There are O-ring oil seals on both the camplate and the quadrant. If oil leakage is noticed at the bolts for these components, the seals should be replaced.

4. Examine the gear bushes. They should be free from any score marks and have a smooth finish.

Except for the layshaft first gear and the sleeve gear, the bushes are a slip fit in the gears. Replacement bushes are easily fitted.

Layshaft first gear and sleeve gear bushes are pressed in; on late models the sleeve gear bushes are secured by snap-rings. These bushes must be checked in place since removal will destroy them. New bushes are pressed into the gear after chilling the bushes in a freezer for several hours (heating the gear will not work), and must be reamed to the proper size after installation. Do not attempt to replace the bushes unless the correct size reamer is available.

Assembly

1. Fit the mainshaft and layshaft

	Commando 850	Commando 750	Alex, G15CS, N15CS, P-11
CYLINDER			
Bore size (in.)	A:3.0315-3.0320 B:3.0320-3.0325	2.8740-2.8754	2.8750-2.8758
Tappet bore size (in.)	1.865-1.875	1.865-1.875	1.865-1.875
PISTONS			
Piston diameter (in.)	3.0271-3.028	2.8703-2.8713	2.8703-2.8713
Piston clearance (in.)	0.0045	0.0045	0.0045
Piston ring end-gap (in.)	0.012	0.013	0.013
Piston ring side clearance (in.)	0.0015-0.0035	0.0015-0.0035	0.0015-0.0035
Wrist pin diameter (in.)	0.6867-0.6869	0.6867-0.6869	0.6866-0.6868
VALVE TRAIN			
Intake Valve			
Head diameter (in.)	1.490	1.490	1.500
Stem diameter (in.)	0.3105-0.3115	0.3105-0.3115	0.309-0.310
Exhaust Valve			
Head diameter (in.)	1.302	1.302	1.312
Stem diameter (in.)	0.312	0.312	0.311
Valve Guides			
Bore (in.)	0.3135-0.3145	0.3135-0.3145	0.3135-0.3145
Valve Springs			
Free-length (inner) (in.)	1.482	1.531	1.531
Free-length (outer) (in.)	1.618	1.700	1.700
Pushrods			
Length (intake) (in.)	8.130-8.166	8.130-8.166	8.194
Length (exhaust) (in.)	7.285-7.321	7.285-7.321	7.351
Rocker Arms			
Spindle bore (in.)	0.4998-0.5003	0.4998-0.5003	0.4998-0.5003
Spindle diameter (in.)	0.4985-0.4998	0.4985-0.4998	0.4985-0.4998
CONNECTING ROD			
Small end bore (in.)	0.6873-0.6878	0.6873-0.6878	0.6873-0.6878
Side clearance (in.)	0.013-0.016	0.013-0.016	0.013-0.016
Big end bearing clearance (max) (in.)	0.001	0.001	0.001
CRANKSHAFT			
Con rod journal diameter (in.)	1.7504-1.7509	1.7504-1.7509	1.7500-1.7505
Bearing journal (drive) (in.)	1.1812-1.1815	1.1812-1.1815	1.1812-1.1815
Bearing journal (timing) (in.)	1.1812-1.1815	1.1807-1.1812 (ball) 1.1812-1.1815 (roller)	1.1807-1.1812
Main bearing (drive) (mm)	30 x 72 x 19	30 x 72 x 19	30 x 72 x 19
Main bearing (timing) (ball) (mm)	—	30 x 72 x 19	30 x 72 x 19
Main bearing (timing) (roller) (mm)	30 x 72 x 19	30 x 72 x 19	—
CAMSHAFT			
Bearing diameter (in.)	0.8735	0.8735	0.8735
Bush bore (in.)	0.8750	0.8750	0.8750
PRESSURE RELIEF VALVE SPRING			
Free-length (in.)	1.171	1.171	1.171
OD (in.)	0.430-0.435	0.430-0.435	0.430-0.435
INTERMEDIATE PINION			
Shaft diameter (in.)	0.5610-0.5615	0.5610-0.5615	0.5610-0.5615
Bush bore (in.)	0.5620-0.5627	0.5620-0.5627	0.5620-0.5627

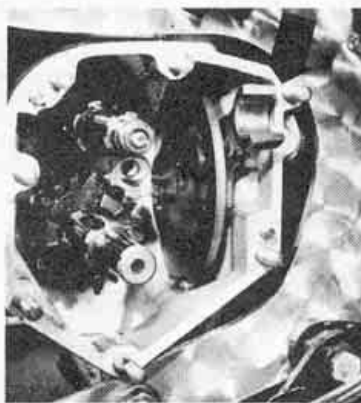

Quadrant upper radius aligned with stud and camplate installed

bearings in the case by driving them in. The case should be heated slightly to aid installation. Note that the mainshaft bearing is installed with the sealed side outward. Do not forget the spacer which fits in the mainshaft oil seal.

2. Fit the shifter quadrant, securing it

with its bolt and washer. Raise the quadrant so that the very top arm is in line with the top right-hand stud on the transmission case.

3. Insert the cam plate, positioning it so that only the first two teeth on the quadrant are visible through the camplate slot. When the camplate plunger is fitted, the plunger will rest in the High gear notch of the camplate. Secure the camplate with its bolt and washer. Fit the camplate plunger, spring, and domed nut.

4. Replace the sleeve gear, making sure that the spacer which bears on the oil seal is in position.

5. Fit the transmission sprocket and secure it with its nut. The nut has a left-hand thread. Tighten it firmly. Hold the sleeve gear in position to tighten the nut by wrapping a length of drive chain around the sprocket and securing one end. Fit the locking plate and screw.

6. Fit the third gear onto the layshaft noting that the boss on this gear faces the fourth layshaft gear. Tap the fourth layshaft gear onto its shaft. Note that this gear has a small boss on one side which must face the layshaft bearing.

Norton

7. Install the mainshaft with the third gear in place on the shaft. Install the layshaft with third and fourth gears in place.

NOTE: The layshaft should be pressed into its bearing by hand and should be reasonably tight once in place. If the shaft cannot be inserted by hand, use a fine emery cloth to work the end of the shaft until this is possible. Otherwise removal of the shaft will be very difficult.

8. Install the mainshaft second gear complete with its shift fork, engaging the shift fork stud into the camplate slot. Note that the camplate may be rotated to the Neutral position (shallow notch), to facilitate installation.

9. Install the layshaft second gear complete with its shift fork and engage the fork stud into the camplate stud. Line up the bores of the shift forks and install and tighten the shift fork spindle.

10. Fit the first gears, noting that the boss on the mainshaft first gear faces outward.

11. Install the roller into the shifter quadrant holding it in place with some grease if necessary.

NOTE: The roller cannot be installed once the inner cover is fitted.

12. Fit a new gasket. Install the inner cover. Using a wrench on the camplate bolt, check that the gears can be shifted. Check that the shifter quadrant clears the cut-out in the inner cover when in the First gear position and Fourth gear position. If it does not, the quadrant and camplate are improperly indexed, and the transmission will not have all gears when completed.

13. Refit the inner cover as previously described.

TRANSMISSION

Mainshaft diameter (clutch side) (in.)	0.8095-0.8105
Mainshaft diameter (kickstarter side) (in.)	0.6244-0.6248
Mainshaft bearing (kickstarter side) (in.)	$\frac{3}{4} \times 1\frac{1}{16} \times \frac{7}{16}$
Mainshaft bearing (clutch side) (in.)	$1\frac{1}{2} \times 2\frac{1}{2} \times \frac{3}{4}$
Layshaft bearing (clutch side) (mm)	17 x 40 x 12
Layshaft diameter (clutch side) (in.)	0.6087-0.6092
Layshaft diameter (kickstarter side) (in.)	0.6845-0.6855
Sleeve gear bearing (OD) (in.)	1.2495-1.2500
Sleeve gear bush (OD) (in.)	0.9055-0.9060
Sleeve gear bush (reamed in place) (in.)	0.812-0.813
Layshaft first gear bush (reamed in place) (in.)	0.6865-0.6875
Clutch bearing (Commando) (mm)	35 x 62 x 14

Torque Specifications

Part	Torque (ft/lbs)
Cylinder head $\frac{3}{8}$ in. nuts and bolts	30
Cylinder head $\frac{5}{16}$ in. bolt	20
Cylinder base nuts	
large front	30
small front	20
others	25
Cylinder allen bolts (850)	30
Connecting rod bolts	25
Rocker shaft cover plate bolts	8.3
Cam chain tensioner nuts	15
Crankshaft nuts	
750	35
850	30
Alternator stator	10
Alternator rotor nut	80
Engine mounting nuts	25
Oil pump nuts	15
Oil feed banjo bolts	15
Oil pressure relief valve	25
Gearbox inner cover nuts	12
Clutch nut	70
Mainshaft nut	50

Lubrication System

Oil Pump

REMOVAL AND INSPECTION

When rebuilding a severely damaged engine, the pump should always be inspected.

1. Remove the timing cover, after taking off the tach drive (if necessary), and disconnect the rocker oil feed pipe at the cover.

2. Remove the two nuts which secure the pump body and pull off the pump. Remove the oil pump gasket, if fitted.

3. Slowly turn the driveshaft and note any roughness or binding in the movement. The driveshaft should turn smoothly.

4. Grasp the driveshaft gear firmly and push and pull on it. There should be no end-play whatsoever if the pump has oil in it.

5. Check the face of the pump body which mates with the crankcase. Place a straightedge across the stud holes to ensure that the body is not warped. It must, of course, be perfectly flat, or air will be introduced into the oil flow. The mating

surface may be lapped flat if necessary after dismantling the pump.

6. Check the conical oil seal on the steel nipple. It must be in very good condition and not deformed. If the seal has been subject to too much pressure, the tapered end will be forced into, and perhaps obstruct, the major oil passage in the timing cover.

Disassembly

1. It is not necessary to remove the pump drive gear to get at the internals,

but it may be taken off the driveshaft if desired by taking off the nut which secures it to the shaft and pulling off the gear. Take out the woodruff key also.

2. Remove the four screws in the pump body and take off the brass end plate.

3. Remove the iron plate from the pump body.

4. Using a brass drift, if necessary, tap out the driveshaft. The return side (wide) gear is a close fit on the shaft so the drift will probably be needed.

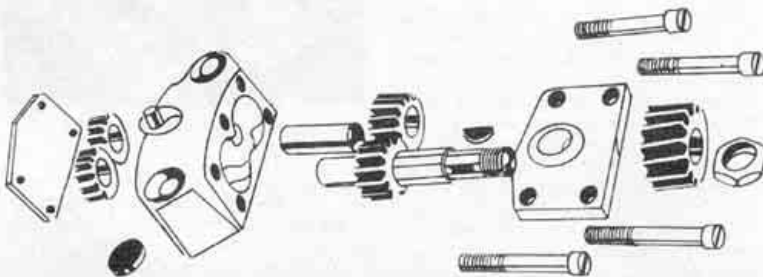

Oil pump disassembled

5. Tap out the shaft for the idler gears. Remove it from the feed side of the pump.

6. Remove both sets of gears.

Inspection

1. Foreign matter in the gear teeth or chipped or worn teeth will be obvious. Under normal operating conditions, however, and assuming that the engine has received routine attention, there should be nothing wrong.

2. If the engine oil in the tank runs down to the crankcase sump after the bike has been sitting for a short time, the problem may be due to loose pump body gears. Another reason may be excessive wear of the shaft bores in the pump body. There is no remedy for this latter cause, other than replacement of the pump body.

3. Check the sides of the oil pump gears and the pump body for wear caused by contact of the gear sides with the body. If there is evidence of wear, assemble the pump dry, and check that there is a slight resistance to turning the driveshaft. If the shaft turns very freely, excessive clearance between the gears and the body may be the cause. Disassemble the pump, and lap the feed side (narrow gears), on a piece of emery cloth placed on a very flat surface. Assemble the pump, tightening the body screws securely. When turning the driveshaft, a slight stiffness should be noted.

Be careful that lapping is done very gradually.

Repeat the procedure on the return gear side. When the pump is reassembled for checking, do not install the feed gears. The driveshaft should be slightly stiff as before.

Finally, assemble the pump completely, and check that the driveshaft is still stiff. Lubricate the pump with motor oil, and continue turning the shaft. Stiffness should disappear as the shaft is turned.

CAUTION: Be certain that the pump body is cleaned out thoroughly after each lapping operation.

Reassembly

1. Clean all of the components thoroughly by washing them in a solvent such as kerosene.

2. Reassemble the gears in their proper positions. The small radius on the return (wider) gears must face the inside of the pump body.

3. Replace the idler shaft and the driveshaft.

4. Place the brass and iron end plates in position and insert the screws, but do not tighten them yet.

5. The end plates must be either perfectly flush or slightly below flush with the edge of the pump body surface which mates with the crankcase. The reason for this should be obvious. There should be just a minimum of play in the end plates which will allow their correct alignment. This is extremely important.

6. Tighten the four screws very securely.

7. Replace the driveshaft key, the drive gear, and the fixing nut.

Installation

1. Oil the pump internals well before installing the pump.

2. Apply some gasket compound to the face of the pump, using it sparingly and being very careful not to get it anywhere near the oil passages. Remember that it will spread along the mating surface when compressed. No gasket compound should be used if a gasket is used between the pump body and the engine as on the 850. A new gasket, however, should also be used.

3. Replace the pump on the studs and gradually tighten the two nuts to 15 ft lbs.

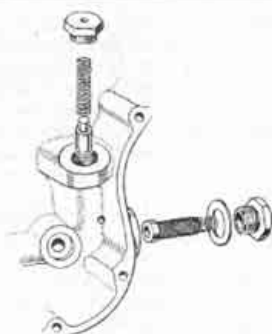

Oil pressure relief valve (Atlas)

not require attention, it does have a wire mesh filter fitted over one end which is easily cleaned after unscrewing the valve.

System Components

CRANKCASE BREATHER

Latest Commandos have the crankcase breather fitted to the rear of the crankcase (750) or at the timing case (850), and no attention is needed for this type. All others, however, have the breather fitted to, and timed by, the camshaft. The breather mechanism consists of a slotted plate with driving tabs to engage the end of the camshaft, and a spring.

The rotating plate opens and closes openings in a stationary plate and this accomplishes the timing of the breather.



Crankcase breather (early models)

The rotating breather plate must be flat on the mating side and it may be worked on a stone to make it so if necessary. The driving tabs should also be in good condition.

The crankcase breather is connected to the oil tank via a rubber hose. If the engine has been standing a while, oil will usually seep into the crankcase and, when the bike is started, it will come out of the breather for a few moments until the oil pump has completely scavenged the sump. While the motorcycle is in operation, especially at high speeds, the breather will pass oil mist or even pure oil. This is normal; the amounts, however, should not be excessive, as this is indicative of oil remaining in the sump.

OIL PRESSURE RELIEF VALVE

The oil pressure relief valve is located on the timing case cover just above the junction for the rocker oil feed pipe. The valve has a spring-loaded steel sleeve which is pre-set to open the valve at an oil pressure of 45-55 lbs per square inch (Commando) or 40-50 lbs per square inch (pre-Commando models). Oil passing through the open valve is diverted back to the feed side of the oil pump on Commandos or into the timing case on earlier machines. Although the valve itself does

OIL LINES

1. All external oil lines should be checked periodically for potential cracks or splits, especially at the joints. If the hoses are secured by screw-type hose clamps, these should not be overtightened or they will crack the rubber.

2. The rocker oil feed pipe is especially important. This unit has been known to crack from vibration. It should therefore be inspected closely, especially if engine work has been done, and the pipe moved about. Arrange the pipe so that it does not touch the barrels or head except at the banjo junctions. Alternately, it can be replaced with a flexible hose as used on the latest Commandos.

The sealing ability of the copper washers used at the banjo junctions can be improved by heating them until they are red hot and then allowing them to cool. Be careful when handling after this operation, however, as the washers will be very soft.

Checking the Lubrication System

OIL PRESSURE

Oil pressure can be readily checked on Commando models with the use of the proper gauge. This is fitted at the rocker oil feed pipe junction and a reading is taken when the engine is at operating temperature. The reading should be 45-55 lbs per square in. at 3,000 rpm.

This method cannot be used for the other models because the rocker arms are fed from the oil return line. The alternative method is to acquire another timing cover. This is then drilled centered with the large oil seal and the gauge inserted. There should be 40-50 lbs per square in. pressure when checked as above, or a minimum of 5 lbs at idle, with the pressure rising with the rpm.

OPERATIONAL CHECKS

If you do not have the proper gauge, the lubrication system can be checked over in some manner by doing the following:

Norton

1. Run engine for several minutes until the oil is warm, then check the oil level at the tank and top up if necessary.

2. Take a short ride to thoroughly circulate the oil. Stop and remove the crankcase sump drain plug. No more than one or two pints of oil should come out as this is done. Be sure to replace the correct amount of oil.

3. Loosen one of the banjo fittings at the cylinder head and, with the ignition OFF, kick the engine over briskly several times. Oil should seep from the loosened banjo as you do this, proving that it is being fed to the cylinder head rocker assembly.

4. Let the machine sit overnight. Upon starting, observe the flow of oil at the return line inside the oil tank. There may be a steady stream for a few moments and then a sputtering return of oil as the sump is scavenged.

5. Check the condition of the oil seals contained in the timing cover. Removal and installation of these seals is described in Engine and Transmission.

CAUTION: Because of a difference in the oil passages, the timing covers found on the Commando are NOT INTERCHANGEABLE with those on earlier machines although they are similar at first sight. Therefore, always be sure that you get the proper timing cover in the event that it must be replaced.

Oil Pump Specifications

Oil Pump Body Material	Cast Iron
Type	Double Gear
Ratio, Feed: Return	1 : 2
Pump Stud Nuts Torque	15 ft lbs
Pressure Relief Valve Spring Free-Length	1.171 in.
Spring Outside Diameter	0.430-0.435 in.
Pressure Relief Valve Torque	25 ft lbs

Fuel Systems

1967 and later models use two Amal Concentric carburetors, while earlier ones are fitted with the Monobloc carburetor. The left-side Monobloc has the float bowl assembly which is used by both carburetors.

Monobloc

Removal and Disassembly

1. Remove the gas tank.
2. Remove the air cleaner.
3. Unscrew the carburetor cap and pull out the slide assemblies.

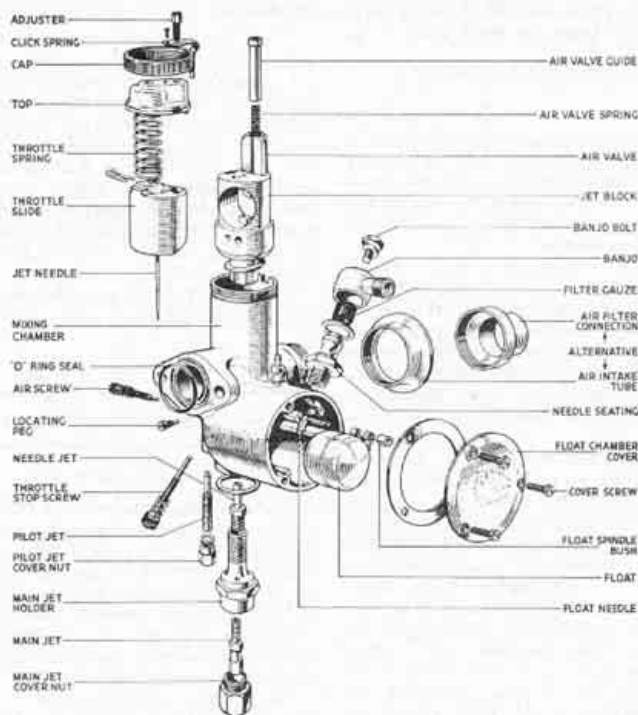

Amal Monobloc

4. To disassemble the slides, remove the needle clip, and disengage the cable from the slide.

5. Gradually loosen the two carburetor flange nuts, and remove the carburetor.

6. Remove the banjo bolt, and take off the banjo and filter screen.

7. Unscrew and remove the float needle seat. Take out the needle.

8. Remove the main jet cover nut. Unscrew and remove the main jet holder complete with main and needle jets.

9. Remove the pilot jet cover nut. Unscrew and remove the pilot jet.

10. If applicable, remove the float bowl cover (3 screws). Remove the float spindle, float, and spindle bush.

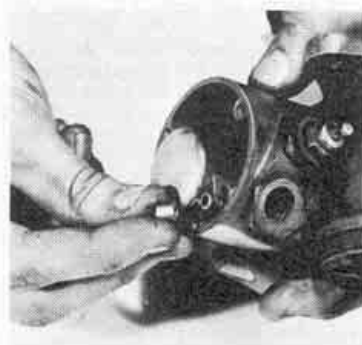

Removing the float spindle bush

11. Remove the pilot air and throttle stop screws.

12. Remove the locating peg, and shake out the jet block.

Assembly and Installation

1. Assembly is the reverse of disassembly. Use new gaskets, O-rings, and fiber washers.

2. Install the throttle slides in the carburetor bodies before tightening the flange nuts. Tighten slowly and evenly, checking for free slide movement as the nuts are tightened. If the slide begins to stick, the nuts are overtightened, warping the carburetor body.



Removing the jet holder and jets

Concentric

Removal and Disassembly

1. Remove the gas tank.

Norton

Carburetor Specifications

	Commando 750 (Combar)	Atlas (up to 1966), P-11	Atlas, G15CS, N15CS
Amal Type	932	930	389/88RH [Ⓢ] 389/871.H
Venturi Size	32 mm	30 mm	1 1/8 in.
Main Jet	230 [Ⓢ]	250	320
Needle Jet	0.106	0.107	0.106
Needle Clip Position	Middle [Ⓢ]	Middle	Lowest notch
Needle	—	—	D
Throttle Slide	3	3	3
Pilot Jet	25	25	25

[Ⓢ] 220 with mute

[Ⓢ] Top with mute

[Ⓢ] 210 with mute

[Ⓢ] 180 with restricted meg; 210 with modified meg

[Ⓢ] Without float bowl

NOTE: Some models, especially in 1966, were equipped by the factory with main jets ranging up to 420 in size. This is far too rich for most applications, especially if the air cleaner and muffler are left stock. The settings were later revised to those shown above.

Electrical System

Ignition System

LUCAS K2F MAGNETO

A magneto ignition is used on machines prior to 1967.

The magneto consists of an armature (with a condenser incorporated) rotating in a magnetic field. The armature is driven by chain from the intermediate sprocket. The centrifugal timing advance mechanism is incorporated in the magneto sprocket and is located in the timing case. The contact breaker points are found on the opposite side of the armature, beneath the magneto cover, and are opened and closed as they rotate inside a cam ring.

The high tension leads contact the magneto slip ring via carbon brushes and these brushes are also used for the "kill button" and the magneto ground, the latter being found beneath the screw on the right-side (top) of the magneto.

Service

1. Every 2,000 miles, clean the breaker points and adjust the gap. Refer to "Tune-Up." Check the gap opening at both firing points on the cam ring. If one is greater than the other, it is best to compromise the value.

2. Apply a small drop of oil to the breaker point pivot. Also, use some high temperature grease to lubricate the cam ring. Be very careful when using any type of lubricant near the breaker points.

3. Every 5,000 miles, remove the high tension pick-ups, and clean off the carbon

brushes. The brushes are mounted on springs and should slide freely in the pick-ups. There must be at least 1/8 in. of the brush protruding from the pick-up for the magneto to work.

Also clean the ground brush after removing its mounting screw.

4. Stuff a clean rag into one of the pick-up holes and kick the engine over a few times to clean off the slip ring. A good deal of oil on the slip ring will indicate a defective oil seal which must be replaced.

5. Remove the timing cover and check the play (up and down) of the magneto sprocket nut. If there is more than 0.005 in. of play, the magneto should be disassembled and the bearings replaced or adjusted.

The following procedure is given for either mechanical (i.e., bearing) or electrical faults:

Removal and Disassembly

1. Remove the timing cover.
2. Remove the magneto points cover.
3. Remove the pick-ups.
4. Unscrew the magneto sprocket bolt and remove the advance mechanism. Remove the two nuts (on studs) and the nut and bolt which secure the magneto to the timing case.
5. Hold the rocker oil feed pipe aside and pull off the magneto.
6. Remove the two safety screws located just by the pick-up holes.

CAUTION: These screws must be removed before the armature is taken out.

7. Remove the points; then remove

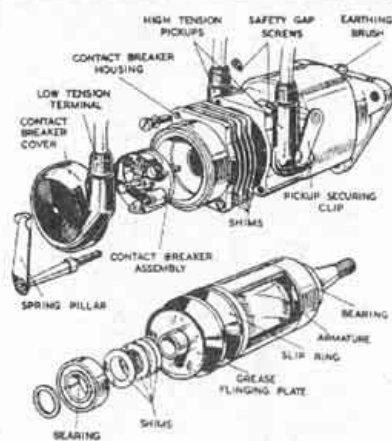

Lucas magneto

the cam ring, which is a slip fit in the magneto case and must be pulled straight out (with the fingers only). Be careful of the lubricating wicks.

8. Remove the two end cover screws and take off the cover. Be careful of the thin metal shims which may be fitted behind the cover.

9. Remove the ground brush and pull out the armature.

10. The magneto sprocket-side bearing race is a press-fit in the housing and a fiber washer is fitted around it. An oil seal is beneath the race. If replacement of the race or oil seal is necessary, heat the housing slightly and tap the race out.

Inspection

1. A simple but relatively effective armature test can be made with a two-volt battery. Screw in the hexagon screw which secures the points into the armature, then connect one of the battery leads to this screw, the other to an ammeter. Then connect the other lead of the ammeter to the ground of the armature itself. The ammeter reading should be about four amps. This is a test of the primary winding.

2. To test the secondary winding (this is the high tension side of the circuit) set

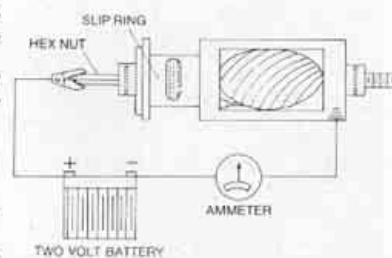

Magneto armature low-tension test

up as above. Obtain a length of high tension wire and clamp one end to ground at the armature, supporting the other end from 1/8 to 3/16 in. from the slip ring contact. Make and break the connection at the hexagon screw several times quickly, and observe the spark produced. The high tension spark must be able to jump at least a 1/8 in. gap.

If no spark is produced, the armature

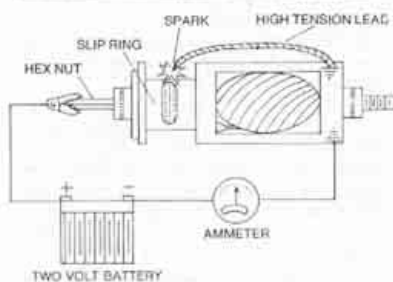

Magneto armature high-tension test

windings or the condenser is defective. Replacement of the complete assembly is the only practical solution.

3. On occasion, a magneto will go intermittent, producing spark on one cylinder, or severe misfiring while running. This is sometimes due to a broken wire within the windings. This cannot be rectified and the armature should be replaced.

4. Magneto bearings are adjustable by removing the thin metal shims from behind the end cover until the end play of the shaft is within acceptable limits.

When the last of these shims have been removed, there is still some possibility of adjustment by adding shims behind the inner races on the armature shaft. However, it requires a special tool to remove or replace the inner races.

Excessive bearing play is most often the result of the drive side outer bearing race, which rides on a rather flimsy fiber insulator, becoming loose.

The ball bearings themselves are held on the inner races by a standard cage. They can be easily removed by simply pulling off by hand as the cage is somewhat flexible.

5. The timing advance mechanism should be inspected. Check for worn sprocket teeth. The two springs which control bob-weight movement should have from 12-14 oz of tension at $\frac{1}{16}$ in. extension.

If the machine has been idle for some time, bathe the advance mechanism in light penetrating oil to assure free movement of the weights.

If the timing cover has not been removed, the efficiency of the timing advance mechanism can be checked by moving the points into the full advance position, when closed. They should return immediately to their normal position when released. If they do not, the advance mechanism is sticking (perhaps the drive chain is too tight) or one or both of the springs may be broken.

Assembly

1. If the sprocket-side bearing race has been removed, fit a new oil seal. Bend the tabs of the insulating washer so that the washer fits the bearing race. Install the washer and press in the race.

2. Lubricate the bearings with a good grade of high temperature grease before installation.

3. Refit the armature, the ground brush, safety screws, and end cover.

4. Replace the point's cam ring.

NOTE: As on removal, the cam ring

must slide directly in. It must be done by hand. Do not force the ring into place. Note that the ring is notched to align with a small stud in the end cover.

5. Replace the points assembly. The backing plate is "keyed" and must align with its slot. Replace the hexagon screw.

6. Replace the complete magneto and place the timing advance mechanism on the armature shaft.

7. Adjust the magneto drive chain and set the ignition timing.

CAPACITOR IGNITION

The capacitor ignition system utilizes a dual-point and dual-coil set-up. A capacitor is wired in parallel with the battery and should provide spark even if the battery condition is low.

To check each of the components in the event of a lack of spark, follow these procedures:

Ignition Coils

1. The ignition coil for each cylinder can be checked by inserting a nail or other suitable conductive object into the spark plug cap and holding this about $\frac{1}{8}$ in. away from the cylinder fins while kicking the engine over briskly. A spark should be able to jump the gap.

2. Pre-1970 and some 1972 models use the Lucas 17M12 coil. The primary winding can be checked by connecting an ohmmeter across the low tension terminals (white and black-white leads or white and black-yellow leads). The reading for the 17M12 coil should be 3.3-3.8 ohms.

Late models are equipped with 17M6 coils. These are 6 volt coils, although the rest of the electrical system remains 12 volt. The 17M6 coils have a ballast resistor wired in series. Resistance for the primary winding is 1.7-1.9 ohms.

The ballast resistor can be tested and should yield a value of 1.8-2.0 ohms.

Condensers

To test the condensers, turn on the ignition and take voltage readings across each set of contact points when open. If no reading is obtained, the condensers have broken down and must be replaced.

If a voltage reading is obtained but there is noticeable arcing and pitting of

the ignition points, the condensers should be replaced.

On 1970 models, the condensers are fastened to the coil clips and are reached from beneath.

On 1971 and later models, the coil assembly must be removed and then the condenser pack (2 screws and nuts). Remove the rubber cover which will reveal the condensers mounted individually to the base plate.

2MC Capacitor

The large Lucas 2MC capacitor is mounted in a coil spring secured to the frame.

1. The capacitor should be checked periodically; this can be done by simply disconnecting the battery (tape up the leads to avoid the possibility of a short circuit). The machine should be able to start and run normally. The lights should still work, although they may dim at low revs, getting brighter as engine speed increases.

2. The capacitor should be mounted with the terminals downward. The single terminal (marked with a red dot) is positive and the double terminal is negative. The terminals are also different sizes, making reversal of the connections almost impossible.

NOTE: If, by some accident, the connections are reversed, the capacitor will be ruined.

3. The capacitor can also be checked by removing it from the machine and connecting a fully charged 12 volt battery across it, leaving it this way for about five minutes. Then, disconnect the battery and let the capacitor sit for another five minutes. At the end of this time, a DC voltmeter connected across the capacitor terminals should give a reading of at least 8 volts.

The capacitor has a limited storage life of approximately 18 months at 68° F. or 9 to 12 months at 86° F. Therefore, it would be wise to check the condition of the capacitor regularly.

Charging System

IMPORTANT: All models are equipped with a 12 volt POSITIVE GROUND system.

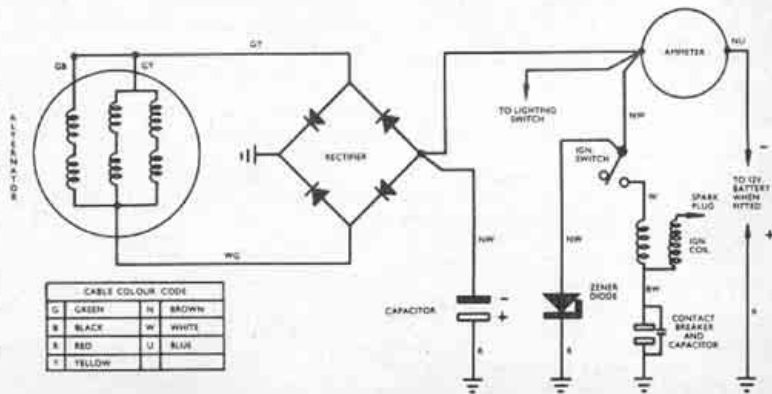

Simplified diagram of Commando wiring system.

Norton

The charging system consists of the alternator, rectifier, zener diode, and the battery itself. 1975 and later models have two diodes.

The alternator produces alternating current by means of a permanent magnet rotor mounted on the left-side of the crankshaft, which rotates within a stationary six-pole laminated iron stator assembly. Three stators have been used and they are easily distinguishable: the RM15 has three leads while the later types RM21 and RM23 have two leads.

The current produced by the alternator is "rectified" (changed to direct current) by the three-plate rectifier.

The amount of charge which the battery receives is determined by the zener diode. This is essentially a variable resistance ("semi-conductor" is the proper term) which automatically raises or lowers the amount of current flowing into the battery according to its condition and needs.

Although the two types of alternator are similar, charging system troubleshooting procedures are provided for each alternator model.

RM15 SYSTEM

There are several types of this model alternator fitted. Nos. 540, 210, and 18 are found on magneto equipped machines, and 047 and 534 on coil ignition machines.

IMPORTANT: For the results of the following tests to be valid, the battery must be in good condition and more than half charged.

Test the system as a whole first by assuring that the battery is receiving the proper charge:

1. Be certain that all electrical connections are clean and tight.
2. Disconnect the 2MC capacitor if fitted.
3. Disconnect the battery negative cable and connect a DC ammeter between the cable and the negative terminal of the battery.
4. Start the engine and run it at 3,000 rpm.
5. Observe the ammeter readings at each of the lighting switch positions.

Switch Position	Alternator RM15 Type	
	540, 210, 18	047, 534
Off	2.75 amps	2.75 amps
Park Light	2.0	1.5
Headlight	2.0	1.5

6. If the readings are higher than those given, the battery may be overcharged. This would most probably be caused by a defective zener diode.

7. If the readings are lower than those given, any one of the other components may be at fault. Perform the test again, but disconnect the diode cable. If the readings become higher, the fault is in the diode, which must be replaced.

If the diode cannot be faulted, the alternator should be checked for voltage output. This requires an AC voltmeter (20 volt range) and a 1 ohm resistor capable of carrying 20 amps without overheating.

1. Disconnect the three alternator leads at the snap connector.

2. Connect the resistor in parallel with the AC voltmeter and check the voltage output between the alternator leads. The following values are the minimum acceptable for an alternator in good condition, with the engine turning 3,000 rpm.

Voltmeter and Resistor connected between leads	Alternator RM15 Type	
	540, 210, 18	047, 534
White-Green and Green-Black	4.0v	4.0v
White-Green and Green-Yellow	6.5	6.5
White-Green and Green-Black*	8.5	9.0
Each lead and ground	0.0	0.0

* With Green-Yellow connected to Green-Black

The following conclusions can be drawn from the test results:

- A. If all readings are low, the rotor has become demagnetized.
- B. If any individual readings are low, a single coil or coils are short circuited.
- C. Zero reading indicates that individual coil or coils are open circuits.
- D. Any voltage reading obtained with the voltmeter and resistor connected to any lead and ground indicates coil or coils internally grounded.

If the alternator tests out okay, the trouble is probably the rectifier. This component is best checked by replacing it with a known workable rectifier. A bench test is given later however.

RM21 SYSTEM

IMPORTANT: Before the following tests are carried out, the battery must be in good condition and close to a full state of charge.

1. Leave the cable connections to the rectifier in place; connect the negative lead of a DC voltmeter (20 volt range) to the center terminal of the rectifier, and the other lead to a ground on the frame or engine. The voltmeter should read battery voltage at this point, if the proper connections are in order.
2. Start the engine and run it at about 3,000 rpm. The voltmeter should register 14.4-16.4 volts.

3. If the voltmeter reading is the proper value, all components are working properly and any trouble with battery charging must be due to the battery itself or to the battery connections.

4. If the voltage reading is higher than the given value, the zener diode is faulty

and must be replaced.

5. If the voltage reading is lower than normal, the alternator, rectifier, diode, or 2MC capacitor can be at fault.

6. If the voltage reading is lower than the given value, perform the test again, but disconnect the diode. The voltage reading should read higher than the regulated value of 14.4-16.4 volts. If it does, the diode is faulty. If it does not, the alternator, rectifier, or capacitor may be at fault.

7. Disconnect the 2MC capacitor and repeat the test. If the voltage reading reaches the normal value, the capacitor is faulty and must be replaced. If it does not, the trouble must be in either the alternator or the rectifier.

8. Test the voltage output of the alternator. Disconnect the two leads at the snap connector and connect an AC voltmeter (20 volt range), with a 1 ohm resistor wired in parallel with it, to the two alternator leads.

9. Start the engine and run it up to about 3,000 rpm. The voltmeter should give a reading of 9 volts if the alternator is satisfactory. If it does, the rectifier is at fault and must be replaced. If it does not, further checks can be carried out to determine the cause of the alternator failure.

The alternator may fail due either to a short or an open circuit in the stator windings or a demagnetized rotor.

1. Connect a 110 volt AC 15 watt test light circuit between the alternator leads (one at a time), and the stator laminations. If the light goes on, there is a short circuit in the windings.

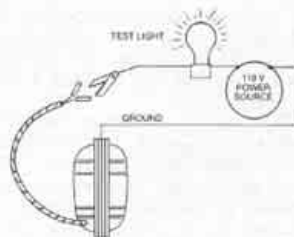

Testing the stator for short circuits

2. It is extremely difficult to carry out a test for an open circuit, so at this point the best thing to do is to fit a replacement rotor and see if this cures the problem. If it does not, the stator is at fault. Since it is plastic-encapsulated, no service is possible and the stator must be replaced.

RM23 SYSTEM

1. Needed for an alternator test are an AC voltmeter and a one-ohm resistor.

2. Disconnect the two alternator leads at the snap connectors and hook up the AC voltmeter across them. Connect the resistor in parallel to the alternator leads.

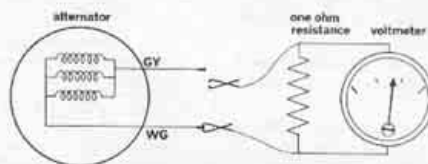

Testing RM21 alternator voltage output

3. Start the engine and run it at 3,000 rpm. The voltmeter reading should be nine volts.

4. If the output is low, the rotor may be becoming demagnetized. The best check is by substitution. If the reading is zero, the stator probably has a broken wire and must be replaced.

System Components

RECTIFIER

A 12-volt test light is needed to carry out the rectifier test.

1. Disconnect the leads and remove the rectifier from the machine. Take care not to disturb the bolt and nut which hold the rectifier plates together as they are set at the factory and disturbing them will affect rectifier output.

2. Assume that the three rectifier plate terminals are numbered 1, 2, 3, and the mounting stud is No. 4.

3. With the test light, check for continuity across the terminals using the following pairs of connections: 1-2, 1-4, 3-4, and 2-3.

4. In each case, reverse the test light leads and again check for continuity.

5. Reading should be as follows: For each connection, there must be continuity in one direction only. If there is no continuity in either direction, or if there is continuity in both directions for one or more of the connections, the rectifier is defective and must be replaced with a new one.

ZENER DIODE

The zener diode accomplishes the function of a voltage regulator. When the voltage across the battery terminals reaches 13.5-15.5 volts, the diode becomes conductive and routes excess voltage to ground.

It is important that the diode always be securely mounted to the heat sink and that the heat sink is firmly attached to the frame. Also, the heat sink should be placed in the cooling airstream.

To test the zener diode, a DC ammeter and voltmeter are needed.

NOTE: When carrying out this test, the battery must be in good condition and have a full charge. Otherwise the test results will not be valid.

1. Disconnect the zener diode lead and connect the positive wire of the DC ammeter to the diode and the negative ammeter wire to the lead.

2. Connect the voltmeter across the diode terminal and ground (positive to ground).

3. Be sure that all lights and accessories are OFF.

4. Start and run the engine; note the following meter readings: when the volt-

meter reads 12.8 volts or less, the ammeter should show zero current flow. When the ammeter shows 2.0 amps flowing, the voltmeter should read 13.5-15.5 volts.

5. If readings do not conform to the above specifications, replace the zener diode.

ALTERNATOR

The alternator requires no maintenance as such, but the following points should be noted:

1. Clean off the rotor and the stator poles from time to time removing any foreign matter, metal particles, etc.

2. Make sure that the rotor is not worn or scored from contact with the stator poles.

3. There must be no contact between the rotor and the stator poles. Ideally, there should be an even gap between the two all around the rotor. This can be checked with a feeler gauge. Clearance should be about 0.010 in. The position of the stator can be altered by using shim washers behind it placed on the housing studs.

4. Before tightening the stator mounting nuts, place an appropriate spacer around the rotor, then place the stator on its studs. Tighten the nuts with the spacer in place. This will help centralize the stator.

Starter Motor

1975 and later models are equipped with a Prestolite starter motor.

Removal

1. Disconnect the starter high-tension lead.

2. Remove the three screws from the primary chain cover flange and remove the starter noting the O-ring.

Disassembly

1. Mount the starter in a suitable vise.

2. Before disassembly, note that the end covers are marked in relation to the body itself and must be properly lined up when assembling.

3. Remove the two through-bolts.

4. Tap the end of the armature with a plastic mallet or the like until the opposite side end cover begins to come off. Stop when the cover has moved about 1/8 in. At this point, hold the armature while attempting to pull off the end cover.

5. After this end cover is removed, tap the brush side of the armature to remove the drive-side end cover.

6. Remove the armature from the starter body, noting that the brushes will spring out as the armature is withdrawn.

Inspection

1. Check the armature bushings for cracks or signs of wear. The drive side bushing can be tapped out with a drift, if replacement is needed, after prying out the oil seal.

The brush-side bushing is removed with a tap.

In both cases, removal and installation can be facilitated by heating the end covers gently.

2. Clean the armature commutator in a solvent to remove any residue or carbon dust.

3. With a continuity tester, check for continuity between each of the commutator segments. All segments must show continuity, or the starter armature must be replaced.

4. Check for continuity between the armature core and the commutator. There must be no continuity here. If there is, replace the starter armature.

Assembly

1. Assembly is the reverse of the disassembly procedure.

2. Before assembly, apply a light coat of molybdenum disulphide grease to each armature bush.

3. After fitting the armature into the body, install the spring shim and thrust washer. Note that the spring shim is closest to the armature.

4. When assembling the end caps, be sure to line up the marks. Use thread locking compound on the through-bolts and torque them to 8 ft lbs. Check that the armature turns easily. Some resistance will be imparted by the brushes which bear against the commutator.

Installation

Be sure that the O-ring is in place when installing the starter.

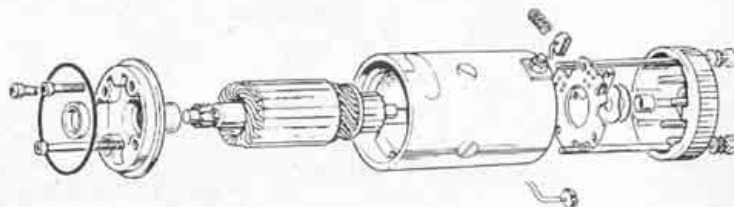

Electric starter assembly

Norton

Wiring Diagrams

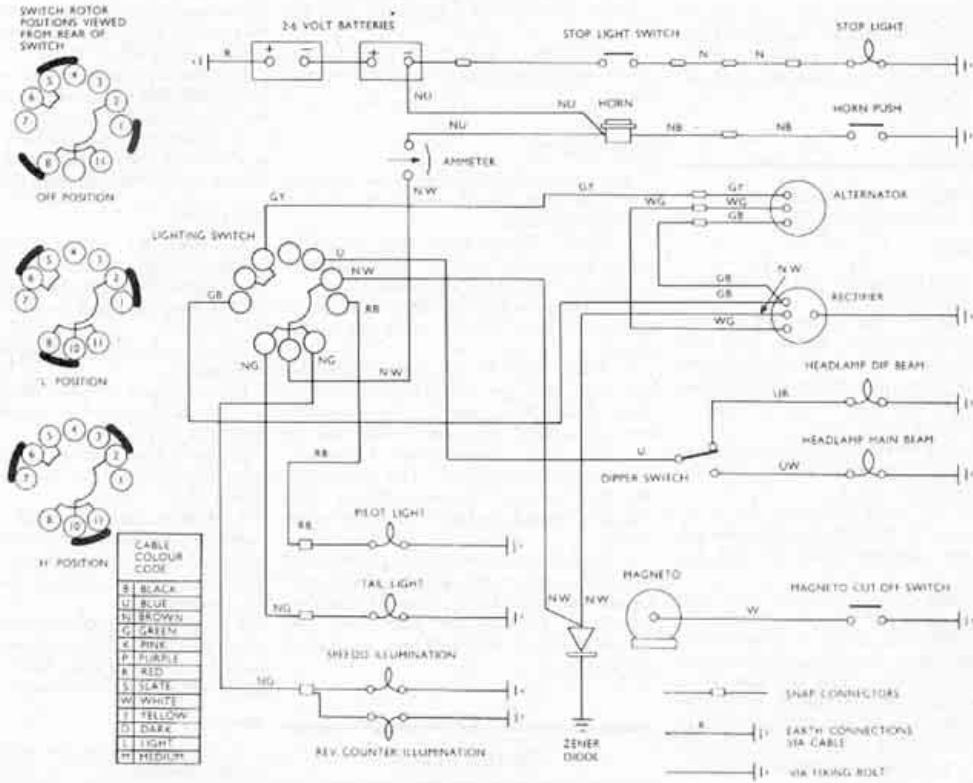

Magneto ignition models

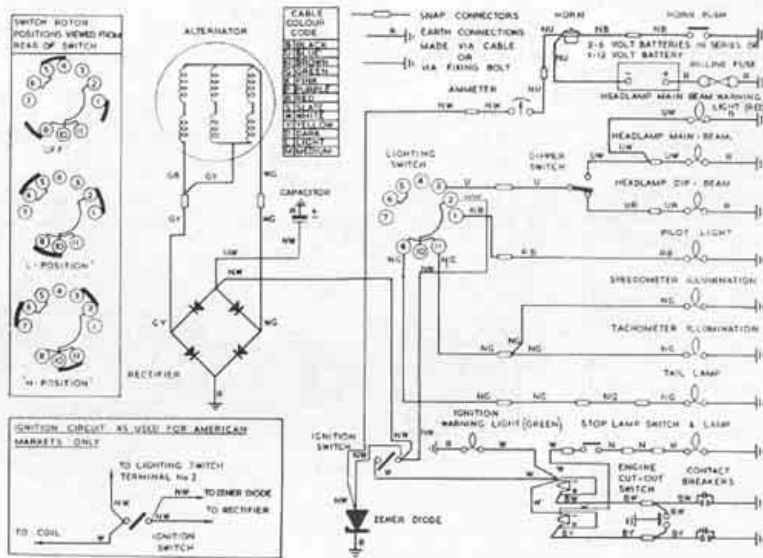

Capacitor ignition 1967 models

Wiring Diagrams

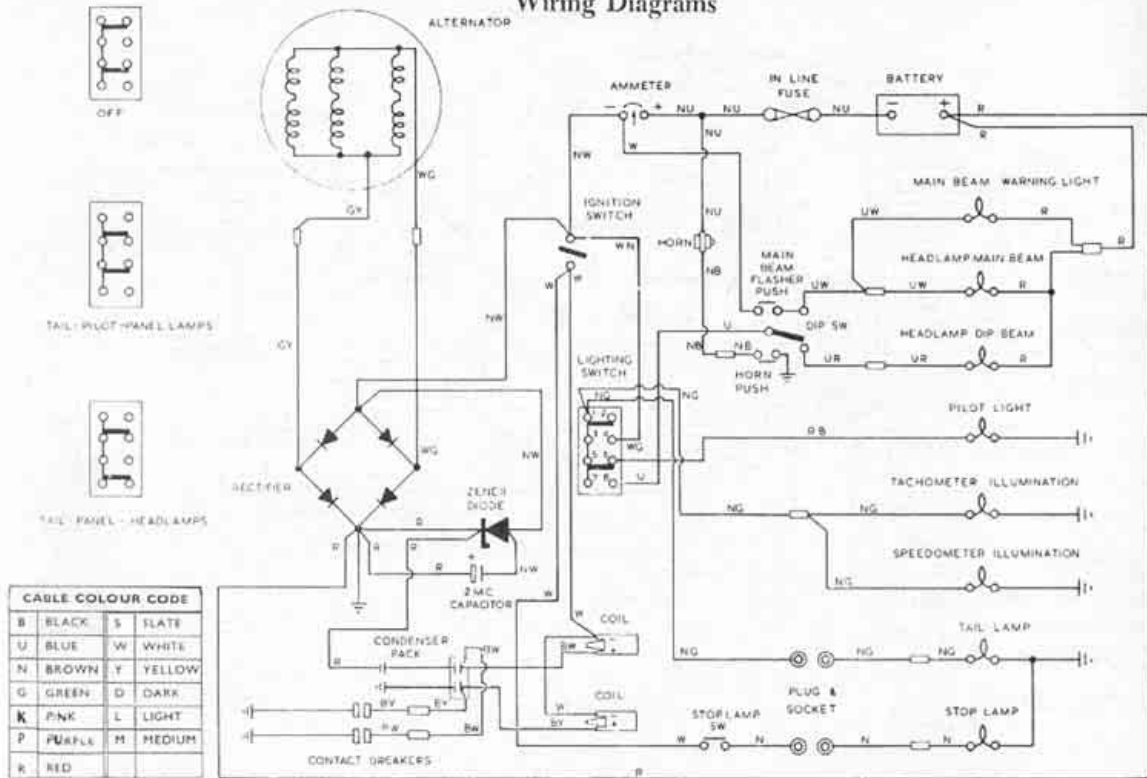

Commando (1968-1970)

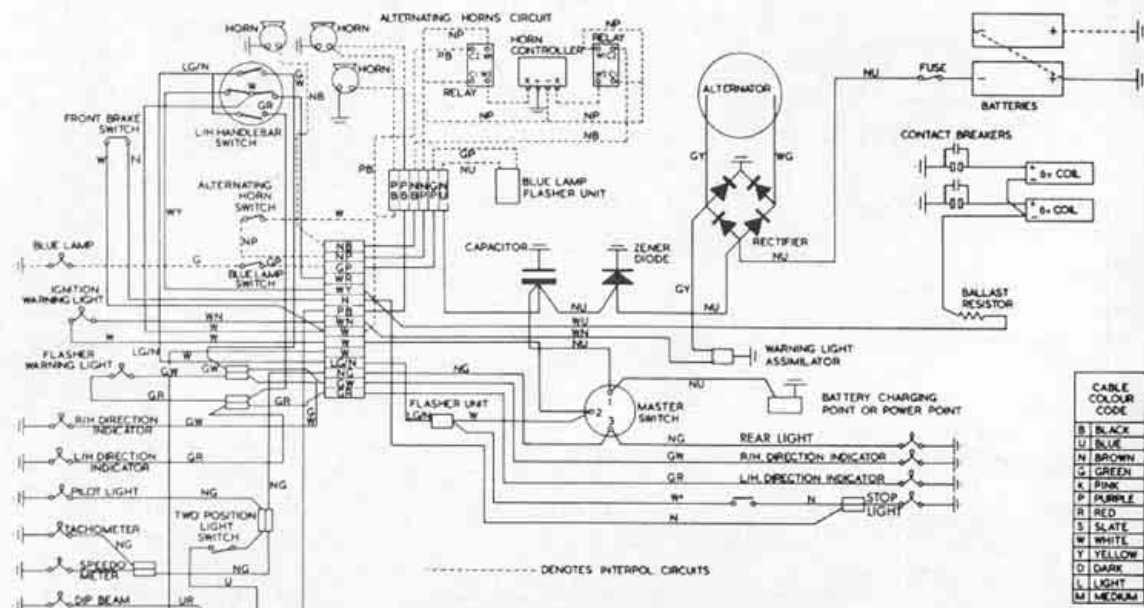

Commando (1971)

Norton

Wiring Diagrams

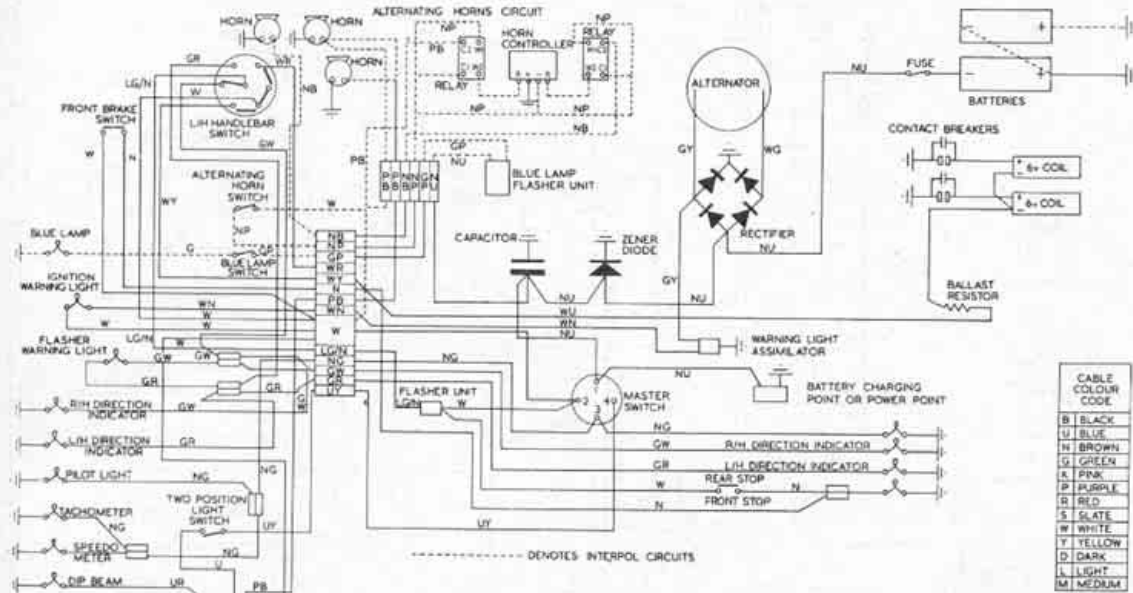

CABLE COLOUR CODE	
B	BLACK
U	BLUE
N	BROWN
G	GREEN
P	PINK
R	PURPLE
R	RED
S	SLATE
W	WHITE
Y	YELLOW
D	DARK
L	LIGHT
M	MEDIUM

Commando (1972-1974)

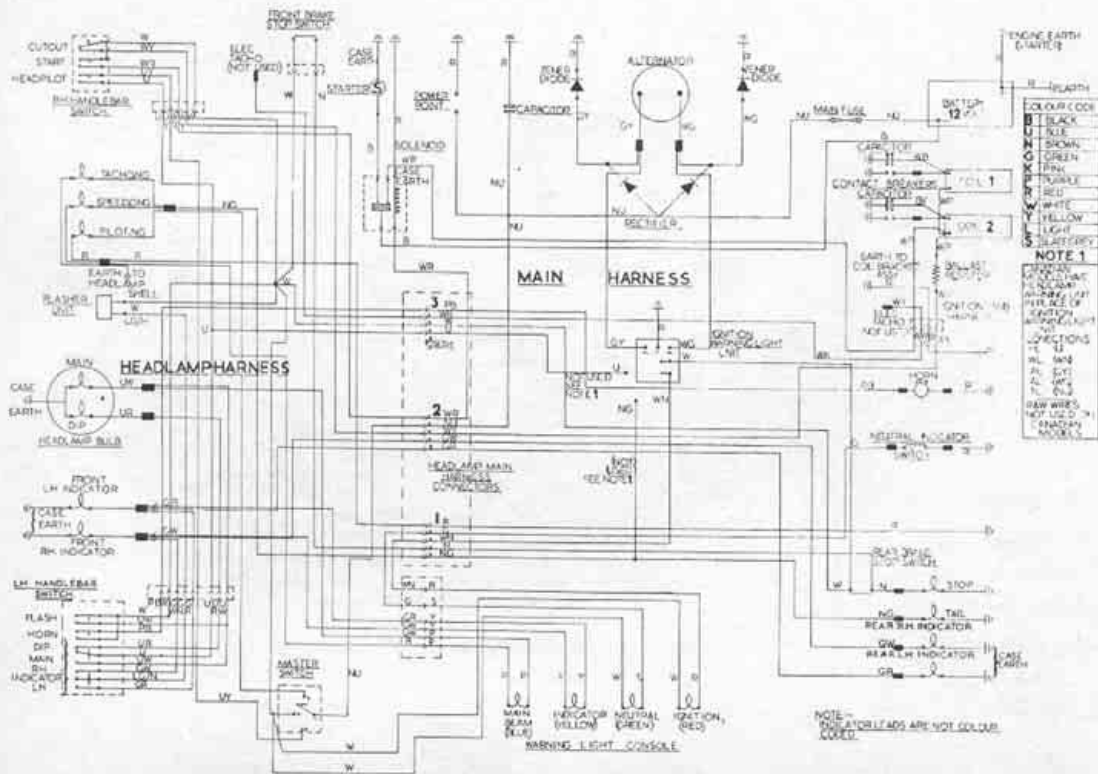

Commando (Mk III)

Chassis

Wheels

FRONT (DISC BRAKE)

1974 and Earlier

REMOVAL AND DISASSEMBLY

1. Support the front wheel of the machine about six inches off the ground by placing a wooden box or wire milk basket beneath the engine.

2. Remove the axle nut; loosen the axle clamp nut on the left fork tube.

3. Slip a suitable bar or a philips screwdriver into the hole in the axle and, supporting the wheel with one hand, pull out the axle.

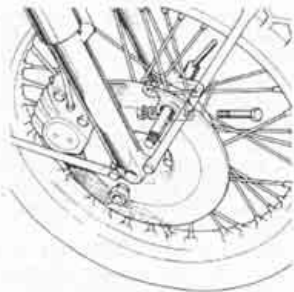

Removing the front wheel (disc brake)

4. Pull the wheel forward, to disengage the disc from the pads, and take it away from the forks.

5. Take off the wheel bearing dust covers to avoid the risk of losing them.

6. Place a 1/4 in. thick spacer of either wood or metal between the brake pads, to prevent their accidental ejection.

7. To disassemble the wheel hub, if this is felt to be necessary, use a peg wrench to remove the locking from the left-side of the wheel. If a peg wrench is not available, the ring can be threaded out by tapping, very carefully, at one of the peg holes with a suitable punch, and unscrewing the ring in this manner.

If the ring resists removal, the hub may be heated very gently with a low flame.

8. Remove any spacers and seals on either side of the hub. Note the order of assembly to facilitate installation.

9. Insert a drift into the right-side of the hub and use it to pry the spacer tube out of the way as far as possible to expose the inner race of the left wheel bearing. Use the drift to drive out the bearing by tapping against the inner race. It will be necessary to move the spacer tube back and forth to tap on both sides of the race. If necessary, the hub may be heated with a rag which has been soaked in boiling water.

10. Remove the spacer tube; then drive out the remaining bearing in the same manner.

ASSEMBLY AND INSTALLATION

1. Assembly is the reverse of the disassembly procedure. Pack the bearings

thoroughly with a good grade of wheel bearing grease.

2. When driving in the bearings, be sure to drive against the outer race only. Fit the left-side (single-row) bearing first, followed by the locking, the spacer, and the right-side bearing assembly.

3. Remove the spacer from the brake pads and install the wheel in the forks with both dust seals in position.

4. Grease the axle and insert it from the left-side of the wheel.

5. Refit the axle and tighten the axle nut firmly. Take the support out from under the bike and work the forks up and down several times. Then tighten the axle clamp nut.

CAUTION: Do not overtighten the clamp nut.

6. Apply the brake hard several times before operating the motorcycle.

1975 and Later

REMOVAL AND DISASSEMBLY

1. Support the machine so that the front wheel is off the ground.

2. Remove the axle nut at the left-side of the wheel. Loosen the pinch-bolt on the right fork leg. Lift the wheel slightly and pull out the axle.

3. Remove the wheel. Do not apply the front brake with the wheel removed. To prevent the brake pads from coming out, fit a 1/4 in. spacer between them.

Note the dust covers on either side of the wheel which should be placed aside to prevent loss.

4. Remove the circlip from the right-hand side of the hub.

5. To heat the hub to facilitate bearing removal, use a rag dipped in boiling water. The hub should not be heated to more than 100° C (212° F).

6. Insert a drift into the hub and use it to pry the spacer tube out of the way as far as possible to expose the inner race of one of the bearings. Use the drift to drive out the bearing by tapping against the inner race. It will be necessary to move the spacer tube back and forth to tap both sides of the race.

7. Remove the spacer tube; then drive out the remaining bearing in the same manner.

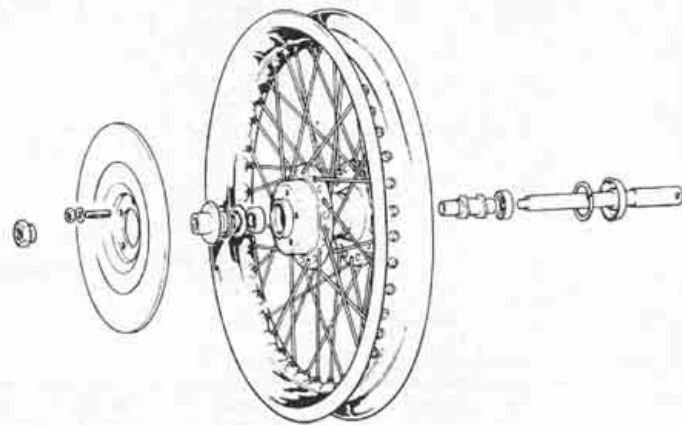

Front wheel assembly (1975 and later)

ASSEMBLY AND INSTALLATION

1. Repack the bearings with a good grade of bearing grease.

2. Press the single-row bearing into the right-side of the hub with the sealed side outward. Do not drive against the inner race. Install the circlip, being sure that it is seated in its groove.

3. Install the bearing spacer tube making sure that it abuts the bearing.

4. Install the remaining bearing with the front axle as a drift. Drive the bearing in until it is completely seated. Install the flet seal, spacer, and dust cover on the right-side of the hub.

5. Install the wheel on the motorcycle.

6. After tightening the axle nut, work the forks up and down a few times to center the wheel, then tighten the clamp nut on the fork slider.

7. Check fork action. If it is stiff, loosen the axle nut and the clamp nut and work the forks up and down. Then tighten the axle nut and clamp nut. If the fork action remains stiff, repeat the procedure with the fender bolts loosened as well.

8. Apply the brake hard several times before operation.

REAR (DISC BRAKE)

Removal and Disassembly

The machine must be firmly supported on the center stand. It is recommended that the stand be safety wired in place temporarily so that the machine does not roll forward during the removal procedure.

1. Engage the transmission in First or Second gear. Loosen the lower right-side shock absorber nut and pull it out as far as the circlip.

2. Unscrew and remove the axle from the right-side.

3. Move the wheel to the left and remove the right-side chain adjuster.

4. Lift the caliper assembly up, but keep the pads in contact with the disc, then squeeze the chain adjuster and insert it between the pads. Hang the caliper upside down from the frame hook provided.

5. Lean the machine to the left and remove the wheel.

6. If desired, the sprocket assembly

Norton

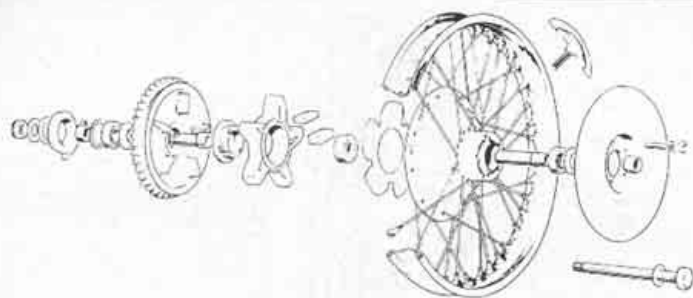

Rear wheel disc brake assembly

may be removed by disconnecting the chain, detaching the speedometer cable, removing the left-side axle nut, and taking off the assembly.

7. To disassemble the rear wheel assembly, first remove the brake disc.

8. Remove the locking on the left-side of the wheel.

NOTE: The locking is a **LEFT-HAND** thread.

9. Remove the small spacer from the right-side of the wheel. The end of the bearing spacer tube will be exposed. Use a soft metal or plastic mallet against the protruding end of the tube to drive out the left-side wheel bearing.

If necessary, the hub may be heated, but to no more than 100° C (212° F), with a rag which has been dipped in boiling water.

10. Use a suitable drift on the left end of the spacer tube and use it to drive out the right-side wheel bearing and oil seal.

11. To disassemble the sprocket hub, remove the bearing circlip and drive out the bearing from the oil seal side.

Assembly and Installation

1. Pack the bearings with grease.

2. Install the disc-side wheel bearing first, driving it straight into the hub with pressure applied to the outer race only. The bearing should be pressed in until it is about 1/16 in. below the lip of the hub. Install the oil seal so that the outer face is flush with the hub lip.

3. Install the spacer tube. Install the left-side bearing. Install and tighten the locking.

4. Install the spacer into the right-side oil seal.

5. To assemble the sprocket hub, drive in the bearing first. Fit the bearing locating circlip, sharp side outward, making sure that it is seated in its groove. Install the oil seal, metal side out.

6. The remainder of the assembly procedure is the reverse of disassembly.

7. Before riding the machine, apply the rear brake hard several times to line up the brake pads.

FRONT (DRUM BRAKE)

Late models are equipped with a twin leading shoe front brake, while earlier ones feature a single leading shoe unit. In either case, the procedures are similar.

Removal and Disassembly

1. Place the machine on the center stand.

2. Disconnect the front brake cable

from the hub.

3. Remove the axle nut, then loosen the axle clamp nut on the left fork leg.

4. Support the wheel to take the weight off the axle, then insert a bar or a philips screwdriver into the hole on the left-side of the axle and pull it out.

5. Watching that the brake anchor clears the slot in the right fork leg, take the wheel out of the forks.

On the P-11, loosen the axle nut, disconnect the brake anchor, remove the axle caps, and remove the wheel.

6. Remove the dust cover on the left-side of the wheel. Remove the brake backing plate assembly from the drum.

7. To disassemble the wheel hub, if this is felt to be necessary, use a peg wrench to remove the locking from the left-side of the wheel. If a peg wrench is not available, the ring can be threaded out by tapping, very carefully, at one of the peg holes with a suitable punch, and unscrewing the ring in this manner.

8. Remove the felt washer. Remove the spacer, noting that the flat side bears against the wheel bearing.

9. Insert the axle through the right-side of the wheel. A few blows with a soft-faced mallet will drive the right-side wheel bearing against the tube spacer, and this in turn will force out the left wheel bearing.

CAUTION: The wheel bearing will not usually "pop" out. In fact, it will be difficult in many cases to notice that it has moved at all. Therefore, after hitting the end of the axle once or twice, try taking out the bearing with your fingers. Under no circumstances should you use undue force on the axle.

10. Take out the axle and insert it into the left-side of the hub. Use the same method to drive out the right-side bearing.

11. Remove the brake shoes from the backing plate by taking out the bolts which secure the fixed end of the shoes

(single leading shoe brake), or removing the circlips (twin leading shoe brake).

Assembly and Installation

1. Pack the bearings with a good grade of bearing grease.

2. Press the left-side (single-row) bearing into place after heating the hub gently to facilitate installation. Tap on the outer bearing race only.

3. Replace the spacer, flat side against the bearing, fit the felt seal, and install the locking.

4. Insert the spacer tube, small end first, into the hub, until it abuts the bearing already fitted.

5. Fit the right-side (double-row) bearing. Be sure that it is fitted squarely into the hub, then drive it home by tapping around the outer bearing race.

6. Fit the thin steel washer (the smaller of the two), the felt washer, and the large steel washer.

7. Secure the large washer by peening it with a punch across the hub. Replace the dust covers.

8. Replace the wheel, slide in the axle, and replace the axle nut, screwing it down only hand-tight.

9. Apply the handlebar brake lever firmly, and, while maintaining pressure here, secure the axle nut with a wrench. This will serve to centralize the brakes in the drum.

10. Take the bike off the center stand and work the forks up and down several times. Then tighten the axle clamp nut.

REAR (DRUM BRAKE)

Removal and Disassembly

1. It is possible to remove the rear wheel without disturbing the rear brake, drive chain, etc. The wheel is secured to the brake drum by three sleeve nuts beneath the rubber caps on the rear hub or, as on more recent models, by three tongues on the brake hub. If your machine has the rubber caps, remove them and remove the sleeve nuts with a suitable socket wrench. On P-11 models, disconnect the brake anchor.

2. Loosen the axle on the right-side of the wheel and pull it out.

3. Remove the spacer on the right-side of the wheel and remove the speedometer drive. It is not necessary to disconnect the cable, simply place the drive mechanism out of the way.

4. Pull the wheel as far as possible to the right-side of the machine, until it is clear of the studs or tongues, then tilt it as necessary to clear the rear fender and pull it out of the machine.

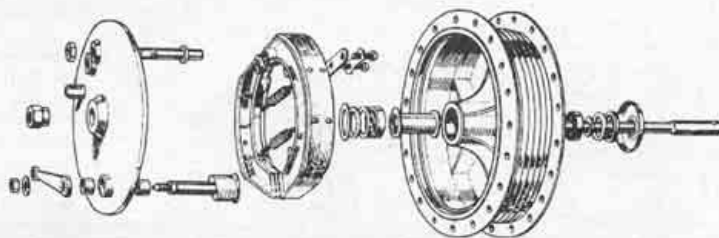

Front hub assembly (pre-Commando)

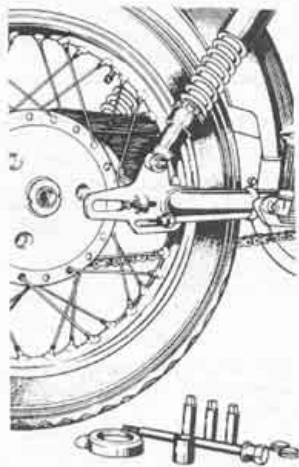

Removing the rear wheel (pre-1971 models)

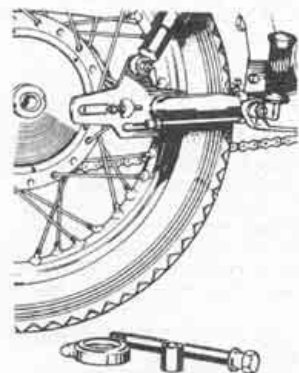

Removing the rear wheel (1971 and later drum brake models)

5. If so desired, the rear brake drum can be removed by removing the chain guard (not necessary on late Commando models with the "chopped" chain guard) and disconnecting the drive chain.

6. Remove the axle nut.

7. Remove the rear brake adjuster nut if the brake is rod-operated, or disconnect the brake cable if it is cable-operated.

8. Take out the brake drum and backing plate, taking care not to loose the large spacer. Remove the brake shoes, if desired, referring to "Front Wheel, Drum Brake," above.

9. If it is desired to remove or lubricate the bearing, remove the locking on the right-side of the rear hub. This ring has a LEFT-HAND thread. Use a peg wrench or a suitable punch and tap the ring to unscrew it. The hub may be heated gently in the vicinity of the ring if it resists removal.

10. Take out the felt washer, being very careful with this item as it is very fragile; also remove the spacer.

11. To the axle, fit the large lock-washer with which it is equipped and the large spacer found between the speedometer drive and the swing arm.

12. Insert the axle into the left (brake) side of the wheel and use a soft-faced mallet to strike the axle smartly once or

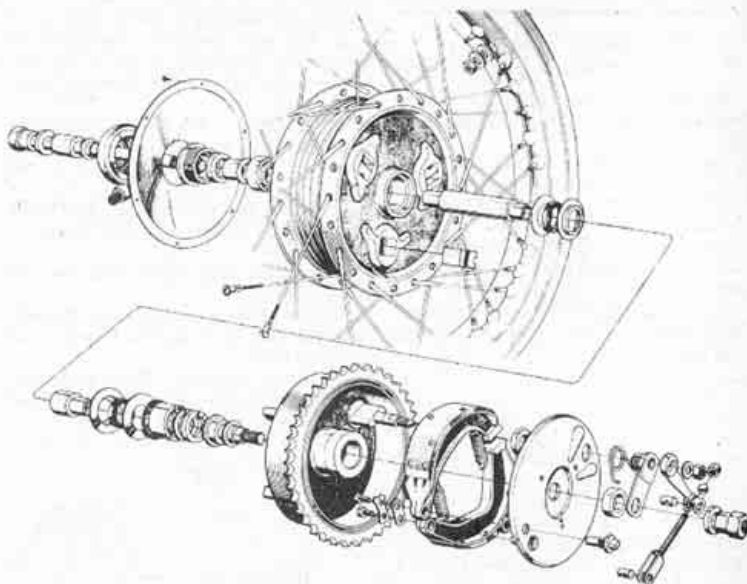

Rear wheel assembly (1971 and later drum brake)

twice. You will feel the brake side bearing give until it bears against a shoulder in the hub. It will have pushed the right side bearing out by an equivalent amount, stop at this point and withdraw the axle.

13. Obtain a short piece of steel tubing with a diameter just slightly smaller than the inside diameter of the bearing. The front wheel axle is suitable for this purpose. Insert the tubing, or the threaded end of the axle, into the brake side bearing, center it, and tap lightly until the right side bearing is driven out. The axle will bear against the spacer inside the hub, which in turn will serve to drive out the right-side bearing.

14. Take out the spacer, if it is still in place, and remove the drift you used. Insert the rear axle (and spacer), into the right-side of the wheel. Carefully center it on the brake side bearing and drive this bearing out with a couple of blows on the end of the axle with a soft-faced mallet. The steel cup washer, felt washer, and thin steel washer will come out with the bearing.

Inspection

1. In 1971, an additional bearing was introduced in the rear brake drum. This bearing should be inspected and lubricated at the same time as the wheel bearings.

2. The three tongues on the brake assembly which drive the wheel must be inspected for security. The tongues are brazed into the brake drum. Note that the brazing material must have run all around the tongue bosses when viewed from inside the drum.

Assembly and Installation

1. Fit the right-side (single-row) bearing into the threaded side of the hub.

2. Fit the tube spacer from the left-side with the long end inserted into the single-row bearing.

3. Refit the spacer, the felt washer, and the locking on the right-hand side of the hub and tighten the locking. Remember, it has a left-hand thread.

4. Replace the brake side bearing and drive it home using the rear axle and spacer as on removal.

5. Fit the thin steel washer, the felt washer, and the cup washer in that order. Peen the cup washer against the hub with a suitable punch.

6. The rest of the assembly is a reverse of the disassembly procedure. Be sure that the speedometer drive is correctly engaged in the slots of the locking before tightening the axle.

Also, apply the rear brake pedal hard, then tighten the axle nut (left-side), while holding the brake pedal on to centralize the brakes in the drum.

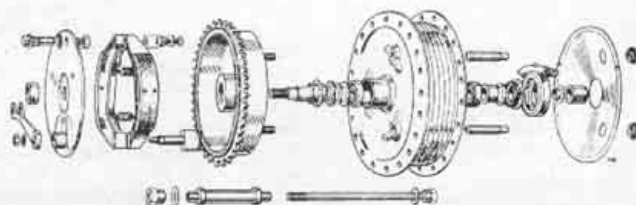

Rear hub assembly (Atlas)

Norton

Disc Brake Service

The following precautions should be observed when working on the disc brake system:

- Use only DOT 3 brake fluid.
- Never reuse brake fluid drained or flushed from the system. Never use brake fluid from an old or unsealed container. Brake fluid is "hygroscopic" (water-absorbing), and is easily contaminated.
- Do not allow brake fluid to contact painted surfaces as it can remove the finish.

FRONT DISC BRAKE

Every 18 months or 24,000 miles (whichever comes first), the hydraulic system should be drained and refilled with fresh brake fluid.

1. Attach a length of plastic tubing to the bleeder screw of the hydraulic unit (as illustrated), placing the other end in a suitable container, assuring that the end of the tube is immersed in a small amount of new brake fluid.

2. Turn the bleeder screw one-half turn.

3. Apply the brake slowly, allowing it to return unassisted. Allow a slight pause between each brake application. Be sure that the master cylinder is kept full by adding the new fluid as needed.

4. When clean fluid, which is completely free of bubbles, emerges from the plastic tube, the flushing operation is complete.

5. Apply the brake lever hard, hold it on, and tighten the bleeder screw.



Bleeding the front disc brake

6. Refill the master cylinder to the correct fluid level (one half inch below the top of the cylinder).

In the event of excessive lever travel or a spongy feel in the front brake, the system must be bled, after first determining the cause of the malfunction.

The bleeding procedure is identical to that for flushing the system as described above, except that it is only necessary to continue the process until the bubbles cease to come out of the plastic tube.

Friction Pad Replacement

- Remove the front wheel.
- Rotate the friction pads slightly

and remove them from the caliper.

3. The pads should be inspected for uneven or excessive wear or scoring. Minimum acceptable thickness is $\frac{1}{16}$ in. (1.5 mm).

4. Clean the pad with the aid of a soft brush. Do not use any solvent or wire brush for removing deposits from the pads.

5. Smear the piston faces and brake pad recesses lightly with disc brake lubricant.

6. Remove the master cylinder cap and bellows seal.

7. Press the pistons back into the caliper, observing the brake fluid level in the master cylinder.

8. Smear the edges of the pad backing plate with disc brake lubricant and press the pads against the pistons.

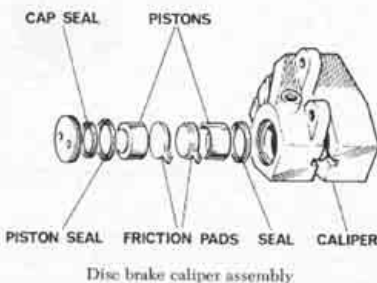

Disc brake caliper assembly

9. Replace the front wheel and spin the wheel while applying the brake lever several times.

10. Check the master cylinder fluid level.

NOTE: If new pads are fitted, they must always be fitted in pairs. Also, the correct pad must be obtained depending on whether the machine is equipped with cast iron, or stainless steel, discs. The latter is identifiable by the part number (063464) stamped on the outer rim. When new pads are fitted, they must be "broken in" for at least 50 miles by avoiding hard application of the brake.

Caliper

If the pistons will not move freely in the caliper, this unit should be disassembled and inspected.

DISASSEMBLY

1. Loosen, but do not remove, the caliper end plug.

2. Remove the two caliper bolts and washers and swing the caliper clear of the fork leg, watching for the brake hose.

3. Remove the two friction pads from the caliper.

4. Clean the outer ends of the pistons and the caliper body with alcohol.

5. Place a can below the caliper to catch the brake fluid. Apply the brake lever, and the inner piston will come out into the pad cavity and the fluid will be released.

IMPORTANT: If the piston is seized, the entire caliper assembly must be replaced.

6. Loosen the lower brake pipe junction nut and separate the pipe from the caliper.

7. Remove the caliper end plug which was previously loosened and drain out the remaining fluid.

8. Remove the piston from the caliper.

9. Remove the pressure seal from the outer bore.

CAUTION: Take extreme care not to damage the seal grooves.

10. Remove the inner piston through the outer cylinder bore. Then remove the pressure seal from the outer bore.

11. Mark the friction pads for position ("inner" and "outer").

INSPECTION

1. Clean the pistons, caliper bores, and seal grooves with ethyl alcohol or clean brake fluid.

2. Examine the pistons for corrosion, wear, scoring, or unevenness of the thrust faces. If there are any irregularities present, the piston must be replaced.

3. Check the caliper bores for corrosion, scratches, abrasion, or damage to the seal grooves.

ASSEMBLY

1. Coat new pressure seals with disc brake fluid and insert the first seal into the inner bore with your fingers, making sure that it is correctly fitted.

2. Coat the inner piston with the brake fluid and insert it into the inner cylinder bore (closed end first) after passing it through the outer bore. Let the piston protrude about $\frac{5}{16}$ in. from the inner bore.

3. Fit the other pressure seal to the outer bore groove.

4. Insert the other piston into the other bore (open end first) until about $\frac{5}{16}$ in. protrudes from the inner mouth of the bore.

5. Replace the end plug. A new O-ring must be fitted.

6. Fit the friction pads and replace the caliper assembly on the fork leg.

7. Torque down the end plug to 26 ft lbs.

8. Examine the fitting of the metal brake fluid pipe for distortion, cracks, or other damage. Fit the pipe into the caliper. Screw down the junction screw until the metal pipe is just lightly seated.

CAUTION: Tighten the junction nut with a wrench no more than 60°. This is VERY important.

9. Loosen the bleed nipple one full turn and connect a bleed tube to it as described earlier in this section. Fill the master cylinder with the recommended brake fluid.

10. Work the brake lever until the fluid begins to flow through the bleed tube. Be sure to keep the master cylinder topped up or air will be drawn into the lines. Hold the brake lever on while adding fluid.

11. When fluid, without bubbles, begins to flow through the bleeder tube, hold the brake lever on and tighten the bleed nipple.

12. Check the brake for sponginess and examine the system for leaks. Recheck the master cylinder fluid level, and fill it up as necessary.

Norton

Master Cylinder

REMOVAL AND DISASSEMBLY

1. Disconnect the brake light switch and lift off the rubber switch cover which exposes the hose junction.
2. Disconnect the hose.
3. Remove the four screws and take off the master cylinder assembly.
4. Remove the reservoir cap and bellows seal. Also remove the brake light switch.
5. Remove the brake lever bolt and the brake lever.
6. Carefully pry out the boot circlip, then remove the boot complete with piston and secondary cup.
7. Remove the primary cup washer, primary cup, spreader, spring, and valve assembly. These parts may be removed by GENTLY tapping the edge of the master cylinder assembly on a wooden block.

INSPECTION

1. Clean the master cylinder and piston in brake fluid or methyl alcohol. Inspect the cylinder body for wear of the piston bore.
2. Make sure that the two ports in the reservoir chamber are clear.
3. Inspect the hose junction for cleanliness.
4. Check the body of the master cylinder assembly for any cracks or fractures, especially in the area of the lever bolt.
5. Check for wear of the piston thrust face.

ASSEMBLY

1. Clean all parts and lay them out for reassembly, referring to the exploded diagram.
2. New primary and secondary cups MUST be fitted. Soak the new cups in hydraulic brake fluid for fifteen minutes, kneading them occasionally.
3. Take the secondary cup and place its non-lipped side against the ground "crown" diameter of the piston. Work the cup over the crown by hand, down the piston body, over the shoulder, and into its groove.
4. Fit the boot over the piston (open end toward the piston crown) and ensure that the boot upper end is fitted into the piston groove. Oil the piston assembly lightly with brake fluid.
5. Assemble the valve to the spring. Make sure that the inner plastic bobbin is

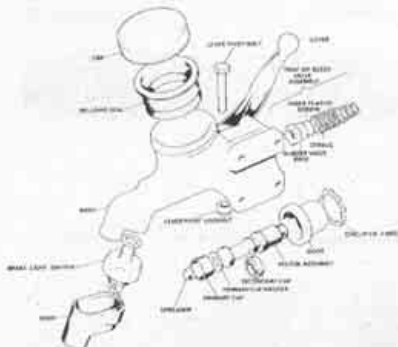

Front disc brake master cylinder assembly

seated in the valve base and that the plastic spreader is pressed securely into the spring.

6. Fit this assembly into the master cylinder, valve end first, holding the master cylinder bore vertical.
7. Place the primary cup into the bore (open end inward), the washer (convex side upward toward the open end of the cylinder bore). Lightly oil the mouth of the cylinder bore.
8. Take the master cylinder assembly in your left hand and insert the piston assembly into the bore.
9. Apply a gentle rotary action to the piston assembly with your right hand, at the same time maintaining pressure downward against the valve spring assembly.
10. Be sure that the lip of the secondary cup enters the bore freely. When the piston has entered the bore, use your left thumb to hold it there and press the lower boot shoulder in.
11. Maintain pressure on the piston and slide the brake lever into position, engaging the thrust pad. Replace the lever bolt.
12. The remainder of the assembly procedure is the reverse of disassembly. Bleed the system as previously described.

REAR DISC BRAKE

1975 and later models are fitted with an hydraulic disc rear brake. Service procedures for the brake system components are the same as described for the front disc brake.

Adjustment

To adjust the rear brake pedal, loosen the locknut which bears against the brake rod clevis and turn the rod to adjust the pedal.

CAUTION: Do not loosen the two locknuts at the opposite end of the rod since this will alter the master cylinder piston stroke. This adjustment is made at the factory.

Front Forks

The fork legs can be removed individually, leaving the steering column in place, or the entire assembly can be taken off at once. The first procedure is given below.

REMOVAL AND DISASSEMBLY

1. Support the front wheel well off the ground. Remove the front wheel, as previously described, and also remove the front fender.
 2. Remove the drain plugs at the bottom of the sliders to drain the oil.
- On 1974 and earlier disc brake models, remove the hydraulic system completely

after placing a 1/4 in. spacer between the brake pads.

On 1975 and later models, the brake system cannot be removed completely. Drain the system completely by means of a tube attached to the bleeder screw. Disconnect the brake line at the junctions. Remove the caliper from the slider. Remove the master cylinder.

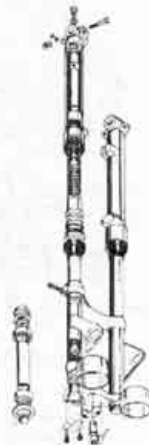

"Slim-line" type forks (Commando)

3. Loosen the filler cap nut at the top of the fork leg until it is clear of the threads in the triple clamp. Then use a thin wrench to loosen the locknut on the damper rod so that the capnut can be removed from the rod. It may be necessary to push up on the fork leg to raise the damper rod enough to gain access to the locknut.

4. Loosen the clamp nut or allen bolt on the lower triple clamp.

5. A sharp downward yank on the fork leg should free the upper end from the upper triple clamp. If necessary, the capnut can be threaded a few turns into place. Then, a sharp blow with a soft-faced mallet should be enough to free the fork leg.

6. Repeat the procedure with the other fork leg.

7. On Scrambler models, remove the external fork springs.

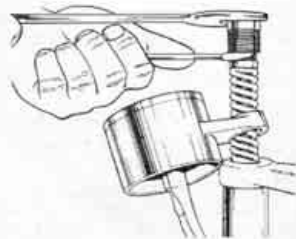

Removing the fork cap nut from the damper rod

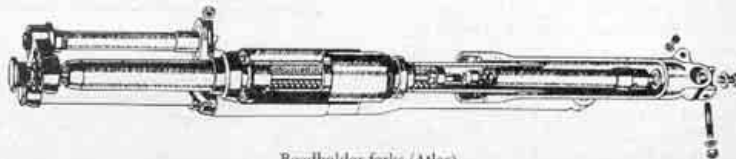

Roadholder forks (Atlas)

normal adjustment procedures do not take play out of the front forks.

NOTE: Latest Commando models have sealed steering head bearings installed and, therefore, the steering head is not adjustable and should not be removed except if damage is suspected as after a collision.

EARLY MODELS

The following procedure applies to early models with adjustable steering stem bearings.

Removal

1. Remove the handlebars, the instrument drive cables, and the light wires.
2. Unbolt the headlight and let it hang from the wiring harness.
3. Remove the fork capnuts and remove the tach and speedometer.
4. Remove the front wheel and fender as previously described.
5. Remove the steering damper, if fitted.
6. Remove the fork crown nut (this is the large nut at the rear center of the upper triple clamp). Give the upper triple clamp a blow from beneath with a soft-faced mallet and remove it.
7. Support the forks and unscrew the bearing race adjuster nut; this is a sleeve nut. Watch for the 18 ball bearings in the upper race.
8. Lower the forks and remove the assembly from the frame.
9. The bearing cups in the frame are press-fit. They can be drifted out, if necessary, using a short piece of steel tubing. The cups must come out parallel to the housing, so move the tubing around the circumference of the cup while driving it out.
10. The cone on the steering column can be removed with a suitable chisel or a screwdriver.

Inspection

1. There are 36 bearings in the steering head assembly (18 in each ball race). Be sure that all are present.
2. Inspect the bearing race surfaces for ripples, cracks, rust, pitting, or signs of wear. The bearing surfaces should be smooth.
3. Make sure that the steering column is parallel with the top ends of the fork tubes.
4. Ball bearings are $\frac{1}{4}$ in. in size. They



Adjusting the steering head bearings (pre-1971 models).

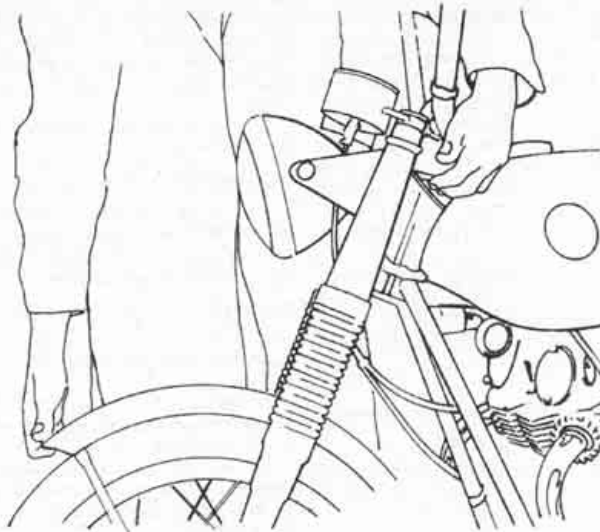

Checking steering head bearings for excessive play

must be in good condition and free from any deformation.

Installation and Adjustment

1. Replace the cone on the steering column and the bearing races in the frame. A draw bolt should be used to press home the races. All traces of paint or foreign matter must be removed to enable the bearings to be repositioned correctly.
2. Place 18 balls in the cone and in the top cup on the frame, holding them in place by embedding them in stiff grease.
3. Replace the dust cover, then thread on the bearing race adjuster nut (sleeve nut). This must be adjusted later. Make it reasonably tight for now.
4. Replace the upper triple clamp and seat it properly. Replace the fork crown nut, but do not tighten it.
5. Replace the front fender and wheel assembly.
6. Check the play in the front forks by grasping the tip of the front fender, pulling forward, and feeling for play with the other hand placed at the junction of the upper triple clamp and the frame.
7. To adjust the bearings, loosen the clamp nuts on the lower triple clamp (be sure that the fork crown nut is also loose), and tighten the sleeve nut with the appropriate wrench until all play in the forks is taken up.
8. Retighten the clamp nuts and the crown nut. Recheck the forks for play and also see that they can be rotated from lock to lock with no binding or tight spots.
9. The remainder of the procedure is the reverse of the removal instructions.

LATE MODELS

Late models feature two sealed ball bearings which do not need lubrication or adjustment. This type is easily identifiable since it has a large nut under the lower triple clamp.

Removal

1. Remove the front forks.
2. Bend back the locktab and remove

the large nut under the lower triple clamp. Remove the triple clamp, tapping down with a plastic mallet while supporting the headlight brackets.

3. Tap the steering stem upward through the bearings to remove the stem and upper triple clamp.
4. The bearings are a press fit in the frame and are separated by a spacer tube. To remove them, move the tube to one side and drift out one of the bearings. Remove the tube and repeat the procedure for the remaining bearing.

Installation

1. Installation is the reverse of the removal procedure.
2. When the triple clamps are installed, do not fully tighten the stem nut. Install the forks, then tighten the fork top bolts, stem nut, and lower triple clamp bolts in that order. Stem nut torque is 15 ft lbs.

Rear Shock Absorbers

The rear shock absorbers are sealed units and the hydraulic damper cannot be serviced. They are adjustable for load and this change is made with the appropriate "C" wrench. The adjuster preloads the spring and turning the adjuster in a clockwise direction provides a stiffer ride when needed (as when carrying two people). Of course, both units must have the same adjustment.

The springs can be removed by:

1. Removing the shocks (one at a time) from the frame.
2. Compressing the spring sufficiently to take out the two keepers at the top.
3. Removing the dust cover (if fitted), and taking off the spring.

NOTE: Grating noises while in operation are usually eliminated by greasing the inside of the dust cover before installation.

Norton

The rear shocks must have some play on their mountings. It should be possible to twist the shocks slightly to either side and have them return to the center position when released. If the shocks are unable to move in this manner, remove them and check the steel mounting sleeves in the eyelets. The sleeves must protrude from the eyelet slightly. If they do not, fit new sleeves.

When fitting shocks, tighten securing bolts to 28 ft lbs.

On Mk III models, check that the bottom of the right shock clears the caliper mounting plate. Clearance can be increased by fitting a spacer behind the shock mount.

Swing Arm

ATLAS

Removal

1. Remove the chainguard. Disconnect the final drive chain.
2. Remove the rear wheel and the brake assembly.
3. Remove the bolts which attach the bottom of the shock absorbers to the frame.
4. Remove the nut and washer from one end of the swing arm spindle and take out the spindle from the other side of the frame.
5. Push the swing arm forward, turn it to one side, and take it out of the frame.

Disassembly

There are two bushes, separated by a spacer. The bushes must be removed and installed with a press.

Assembly and Installation

1. Press in the new bushes.
2. Replace the swing arm in the frame.
3. Replace and tighten the shock absorber bottom bolts before tightening the swing arm spindle nut.
4. Tighten the swing arm spindle nut and proceed with assembly in the reverse of the removal sequence.

G15CS, N15CS

These scrambler models incorporate two oilite bearings in a steel sleeve.

Removal

1. Remove the chainguard, disconnect the chain, and unbolt the rear shocks from the swing arm.
2. Remove the rear wheel and the brake assembly.
3. Take out the cotter pin on the swing arm spindle and press out the steel sleeve. Remove the swing arm. Watch for the two felt washers as the swing arm is removed.

Disassembly

Each bush must be pressed out in turn with a press. Note that they are flanged.

Assembly and Installation

1. The spindle diameter is 0.990-0.995 in. The bushes are reamed, after installation, to 1.001 in.

2. The steel sleeve is oil filled and this is accomplished by removing the filler screw in the cover plate and injecting a heavy grade of oil until the cavity is filled.

3. The remainder of the procedure is the reverse of removal.

COMMANDO (1974 AND EARLIER)

The swing arm pivots on two flanged bushes which are supported by the swing arm spindle which passes through the rear engine mounting plate.

Removal

1. Remove the threaded rod which secures the end plates for the swing arm bushes.
2. Remove the lockbolt, in the middle of the rear engine mounting, which secures the swing arm spindle.
3. The spindle is threaded on the right-side. It must be removed with a 1/2 in. bolt. Thread in the bolt and pull out the spindle.
4. Remove the chainguard. Disconnect the drive chain.
5. Remove the rear wheel and the brake assembly.
6. Remove the bottom bolts on the rear shock absorbers.
7. The swing arm can now be removed from the frame.

Disassembly

1. Remove the large O-rings and dust covers from the swing arm.
2. Take out the small O-rings in the recesses of the bushing housings, then support the ends of the swing arm properly and press out the bushes with an arbor press.

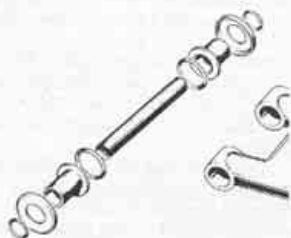

Commando swing arm bushings (to 1974)

Inspection

In the event of a damaged or worn swing arm pivot spindle, oversized units are available. These are 0.005 in. larger in diameter than the stock unit. The spindle bore clearance should be 0.0005-0.0020 in.

To fit the oversized spindle, the bearings should be bored, in place, to 0.8807-0.8817 in.

Assembly and Installation

1. Place the dust cover over the bush. The recess in the dust cover for the large O-ring should face inward.
2. Press in the bushes. Again, an arbor press is used.
3. Refit the large O-rings in the dust covers and the small O-rings in the recess in the bush housing.

4. The rest of the procedure is the reverse of that for removal.

COMMANDO (1975 AND LATER)

Removal

NOTE: New swing arm welch plugs and felt pieces are required if the swing arm is removed.

1. Loosen the right-side shock absorber and pull out as far as the circlips allow.
2. Hang the brake caliper from the hook provided. Remove the rear wheel.
3. Remove the right rear support plate complete with brake, pedal, and footpeg.
4. Pry out the right-side swing arm pivot welch plug. Remove the felt washers.

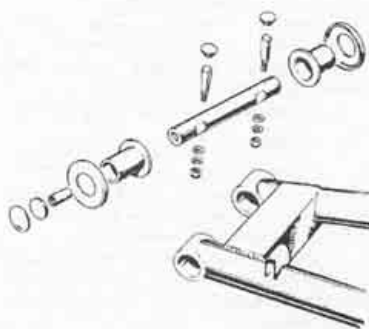

Commando swing arm bushings (1975 and later)

5. Remove the lower rear fender brackets. Remove the oil filter and lines. Remove the horn.
6. Remove the swing arm pivot pins by removing the nuts and driving up from the bottom. Note the rubber plugs.
7. Remove the shock absorber bottom bolts.
8. Remove the swing arm spindle. To do this, screw a bolt with a locknut into the spindle (the main front mounting bolt will work), and pull out the spindle. Disconnect the speedometer cable. Remove the swing arm.

Inspection

1. Check the spindle for wear or scoring. Inspect the bushes for signs of wear.
2. Insert the spindle into place and check for play. There should be none. If play exists, the spindle and the bushes should be replaced.

Disassembly and Assembly

1. Remove the left welch plug.
2. Press out the old bushings.
3. To install new bushes, place the sealing washer over the bush and press it in fully. The bushes do not need to be reamed after installation.
4. Place the felt disc into the recess of the left-side boss after soaking it in SAE 140 oil. Install the welch plug.

Installation

1. Soak the swing arm spindle lubricating wicks in SAE 140 oil and then install one into the left end of the spindle.
2. Place the swing arm into position with the bushes installed and the left-side felt washer and welch plug in place.

Norton

3. Carefully push in the spindle, noting the two cutouts which align with the cotter pins. When the spindle is inserted about half-way, install the left-side cotter pin. Then continue pushing in the spindle until the cotter pin mates with the cutout in the spindle.

4. Install the right-hand cotter pin.

5. Remove the bolt used to install the spindle. Install the oil-soaked felt wick into the right-side of the spindle, then the oil-soaked felt washer, and install the Welch plug.

6. The remainder of the procedure is the reverse of disassembly.



Checking clearance in the front engine mounting (1974 and earlier)

5. To remove the rear engine mounting, the engine, transmission, oil tank, and the swing arm spindle must be removed.

6. The main mounting bush and the rubber spacers are removed with an arbor press. This is also true for the front assembly, although this unit may be taken out of the frame by itself.

NOTE: If proper side-play cannot be obtained, the engine mounting tube may be partially collapsed and must be replaced.

For other engine mounting problems, refer to the following chart:

Frame

PRE-COMMANDO

The rigid frame Nortons require no maintenance in this area other than routine checks of the frame gussets and steering lug for cracks if vibration is high or handling poor.

COMMANDO

The engine and transmission are bolted rigidly together by the rear engine mounting plate. The swing arm, instead of being attached to the frame, is bolted to this assembly, although it pivots independently in the normal manner. Now, the entire engine-transmission-swing arm unit is mounted in the frame at three places by means of polymer filled absorption units. These are located at the very top of the cylinder head, at the front of the crankcase, and above and to the rear of the transmission.

The absorption units must be assembled properly if the system is to work as the designers intended.

The front and rear engine mounting units must be checked for side-play if vibration occurs.

NOTE: When checking the mountings, 1970 and earlier models may be supported on the center stand. 1971 and later models, however, must be supported with a crate or box on which the lower frame rails can rest. These models cannot be checked while on the stand, since this will put tension on the mountings.

1974 and Earlier

FRONT MOUNTING

1. For the front engine mounting, be sure that the engine mounting bolt is torqued to the correct value of 25 ft lbs.

2. The total side-play of the front engine mounting should be 0.020-0.025 in. If the side play is reduced, the mounting bush will not function. Side-play is adjusted by means of shim washers of varying thickness. These are available in four sizes: 0.005, 0.010, 0.020, and 0.030 in.

3. If the engine plate is moved and then released, the assembly should react through the elasticity of the mounting bush. If it does not, the shim washers are too thick.

4. To fit new shims, remove the nut on the left side of the assembly, drive out the bolt far enough so that the spacer and the cap can be removed for access to the shim washer, and replace this with one which will give the correct side-play.

5. Reassemble the mounting, torque down the nut to 25 ft lbs, and recheck the side-play.

REAR MOUNTING

1. Checking the side-play for the rear mount is the same as for the front. The value is 0.010-0.015 in. It should be checked on the right-side of the machine.

2. New shims can be fitted by taking off the nut on the right-side and driving out the bolt far enough so that the spacer and cap can be removed.

3. Replace the shim washer with the one selected and refit the cap and spacer.

4. Torque down the nut (25 ft lbs) and recheck side-play.

1975 and Later

The Isolastic mounts on the Mk III are similar to those found on earlier models, although they incorporate an adjusting device.

FRONT MOUNTING

1. Slide the right-side gaiter back to give access to the adjuster and plastic washer.

2. Push the engine as far as possible to the right to take up all the slack in the mounting. Hold the engine in this position and check the clearance between the plastic washer and the plated adjuster collar. If the clearance exceeds 0.010 in. (0.25 mm), adjustment will be necessary.

3. Loosen the mounting main bolt and slide the spring clip clear of the holes in the adjuster. Use a thin screwdriver or a suitable substitute and turn the adjuster until there is no clearance. Then back off the adjuster 1½ holes.

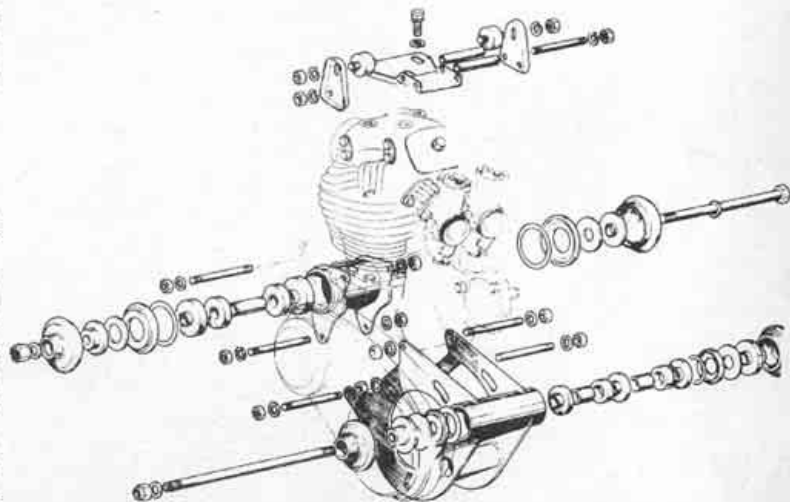

Isolastic mountings (1974 and earlier)

Norton

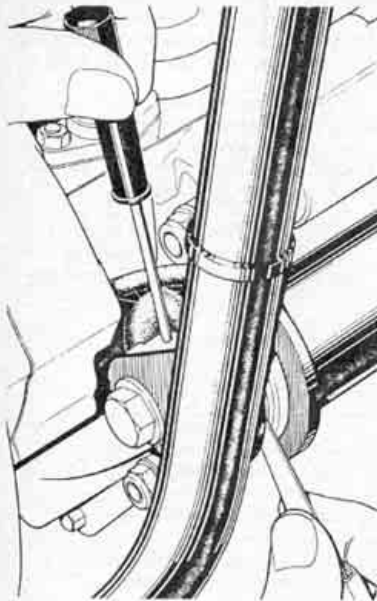

Adjusting clearance (1975 and later)

4. Tighten the main bolt to 30 ft lbs. Clearance should be about 0.006 in. (0.152 mm).

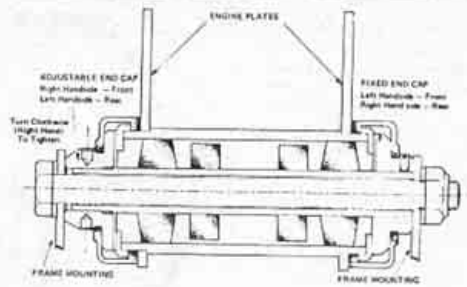

Mounting unit (1975 and later)

REAR MOUNTING

1. Slide the left-side gaiter back to expose the face ring and plastic washer.
2. Push the rear wheel as far as possible to the left and check the clearance between the plastic washer and the plated adjusting collar. If clearance exceeds 0.010 in. (0.25 mm), the mounting should be adjusted.
3. Loosen the mounting main bolt. Insert a small screwdriver or something similar into the adjuster and turn it until there is no clearance. Then back it off 1½ holes. Tighten the bolt to 30 ft lbs. Clearance should be about 0.006 in. (0.152 mm).

Chassis Specifications

Wheel Bearings (mm)	
Front, left side	17 x 40 x 12
Front, right side	17 x 40 x 16
Rear, left side	17 x 40 x 12
Rear, right side	17 x 40 x 16
Torque Wrench Settings (ft lbs)	
Engine Mounting Bolts (All)	25
Disc Brake Caliper Bolts	25
Disc Brake	
Pad type: Steel backed, molded and bonded friction material	
Pad friction area diam. (in.)	1.65
Pad thickness (in.)	0.37-0.38
Disc diameter (in.)	10.70
Disc width (in.)	0.250-0.260