

A
J
S

MOTORCYCLES
1935

INTRODUCTION

To Motorcyclists throughout the World, the name "A.J.S." is synonymous with High Quality, Perfection in Detail, and Superfine Finish. Never have these characteristics been shown to greater advantage than in the 1935 "A.J.S." models described in this Catalogue.

Behind these latest productions of the "A.J.S." Factory is an experience extending over more than a quarter of a century, backed up by a world-wide Dealer organisation, equipped to give Service and ensure the utmost satisfaction to "A.J.S." riders. Every "A.J.S." Dealer is an "A.J.S." enthusiast whose services are at the disposal of all interested in high grade motorcycles.

The "A.J.S." range for 1935 includes models designed specifically for every use and purpose. Tourist, Sportsman, Utility Rider, Racing man—all are catered for by the "A.J.S." Motorcycles described herein.

"A.J.S." performances in the Racing and Competition world are known to all motorcyclists, and proof of the utter reliability of "A.J.S." products is given by the large numbers of "A.J.S." Motorcycles in use by Police Authorities, and other Government Departments and Official Bodies throughout the World.

"A.J.S." Motorcycles are built to a Standard of Quality and not to a Price. They may cost a little more than some others, but they are worth it.

A.J.S. MOTOR CYCLES

Proprietors: MATCHLESS MOTOR CYCLES (COLLIERS) LTD.

PLUMSTEAD ROAD
LONDON, S.E.18

TELEPHONE: WOOLWICH 1010
CODES: A.B.C. 5th EDITION
A.B.C. 6th EDITION. BENTLEYS

TELEGRAMS:
"ICANHOPIT-WOL-LONDON"
CABLES: "ICANHOPIT-LONDON"

EXAMPLES OF A.J.S. "PERFECTION IN DETAIL"

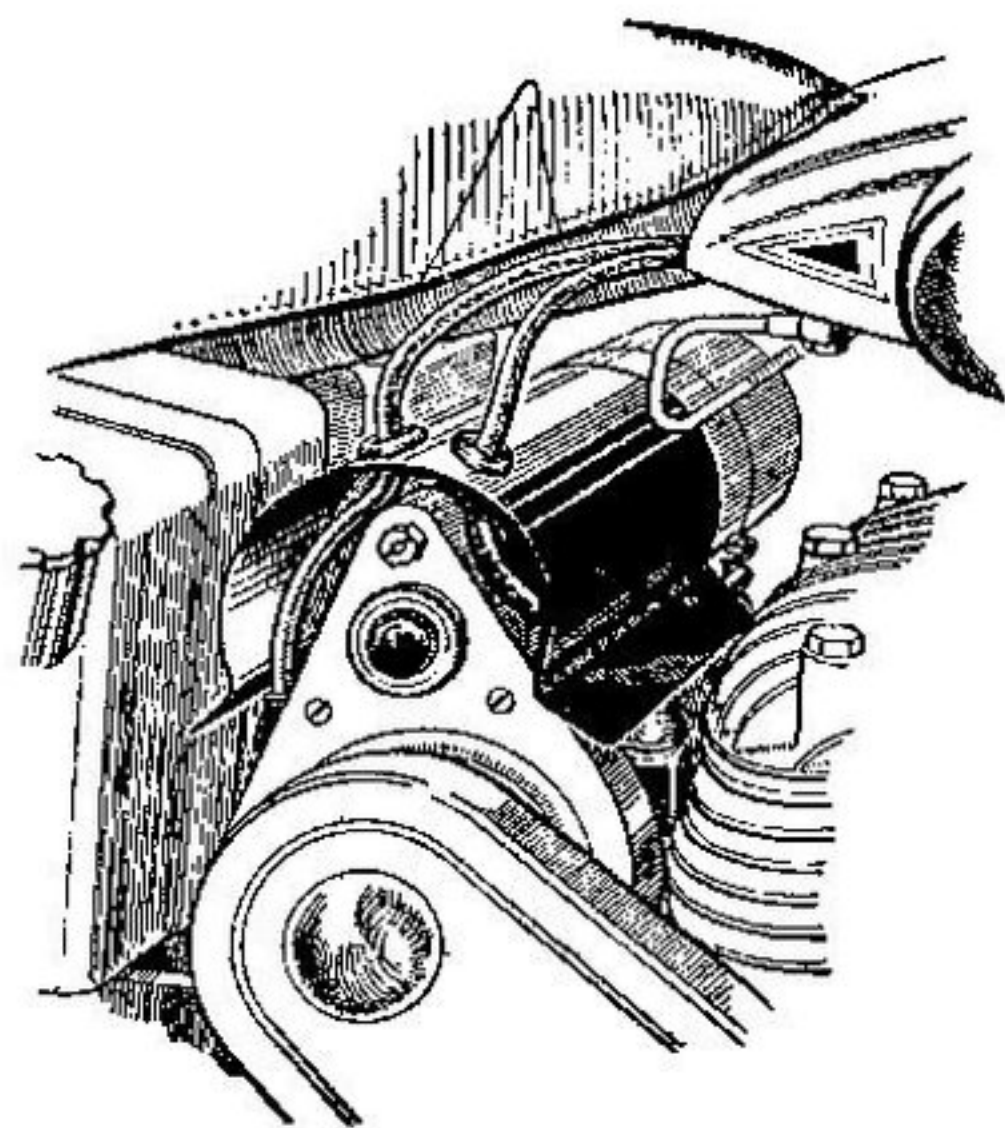

On the Big Twin Models the magdyno is protected by the efficient shield shown above, which ensures reliable ignition even in tropical downpours.

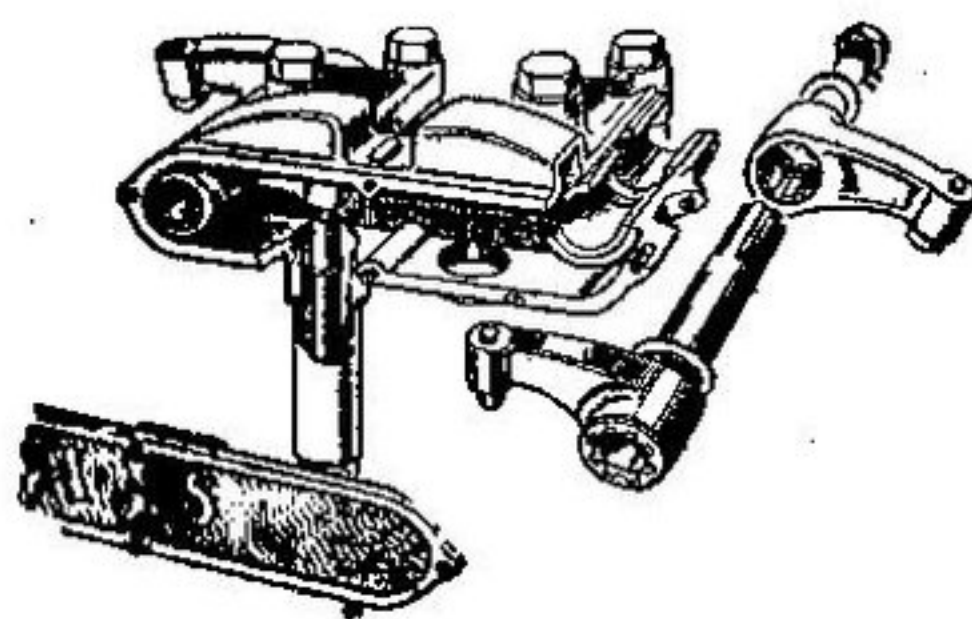

This sketch shows the design of the overhead rocker gear on 35/6, 35/18 and 35/8 Models. The rockers are duralumin forgings, attached by splines to the hollow alloy steel rocker spindles. Observe the ample diameter of the bronze bushes for the spindles and the neat manner in which the ball-ended duralumin push rods are enclosed.

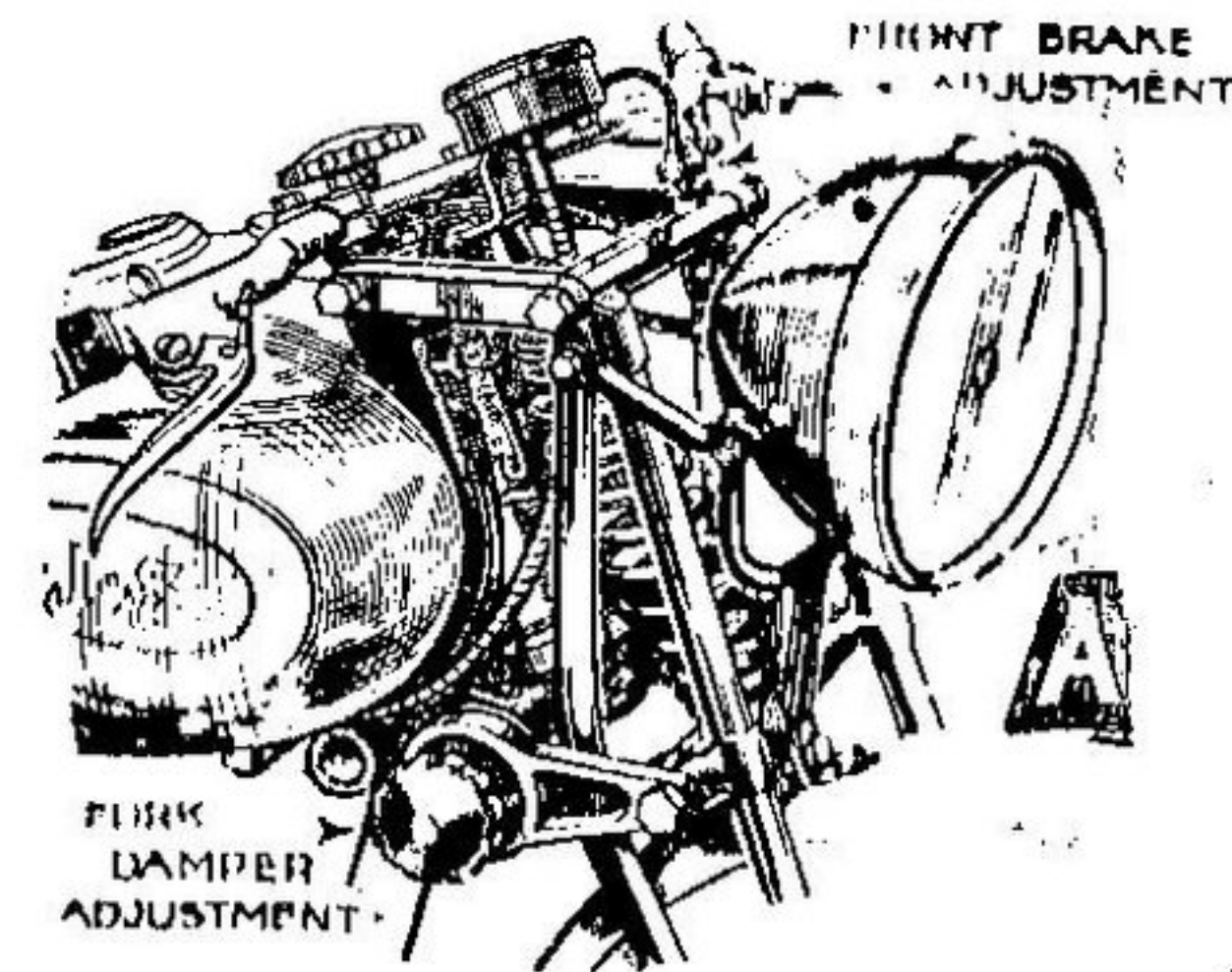

A well-known feature of "A.J.S." Motor Cycles is the exceptionally sturdy front fork assembly shown above. Note the accessible finger adjustment for the front brake, the convenient shock absorber adjustment knob, and the stiff headlamp mounting.

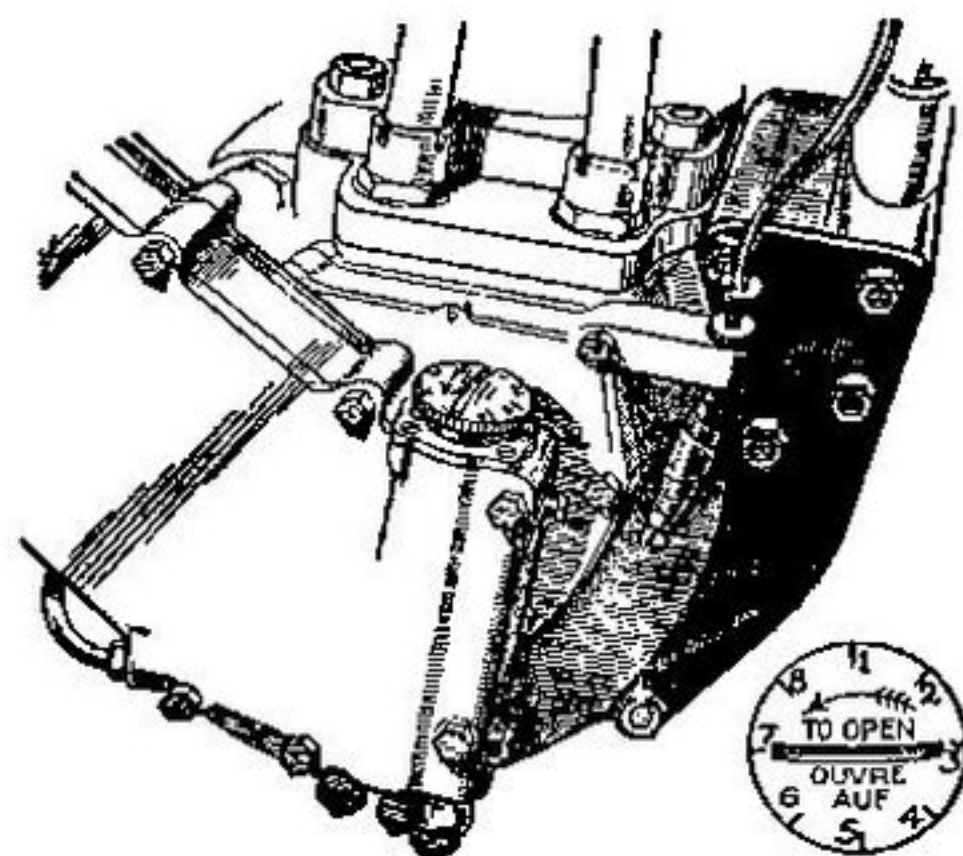

This view shows the simple adjustment for the oil pump provided on Models 35/5, 35/6, 35/8, 35/18 and 35/9.

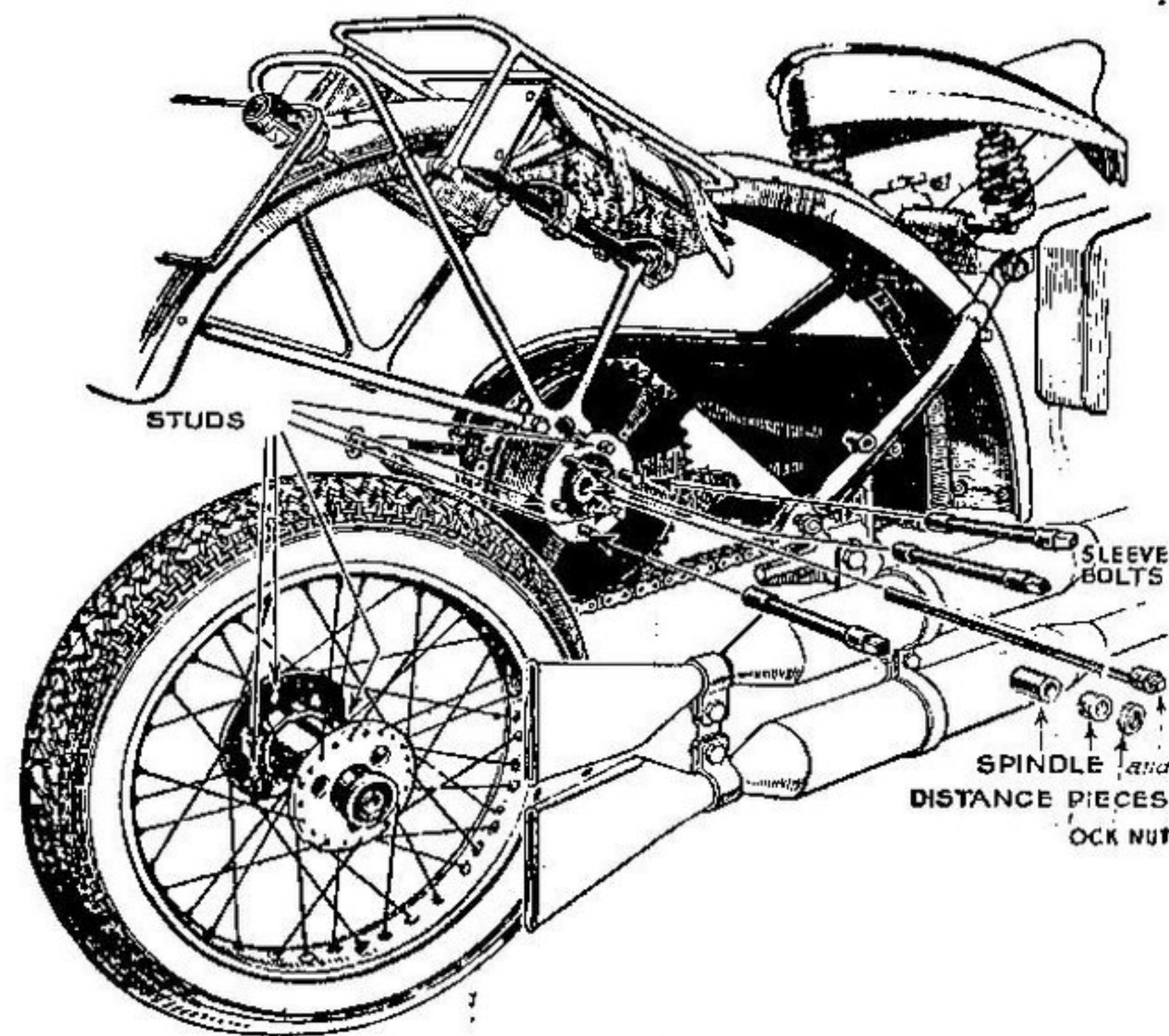

The arrangement of the "A.J.S." quickly detachable wheel is clearly shown above, the wheel being removable without disturbing the chain or brake. This design is used for front and rear wheels of the Big Twin Models, the wheels being interchangeable, and for the rear wheel only of Models 35/6, 35/7, 35/18, 35/8, 35/9 and 35/10.

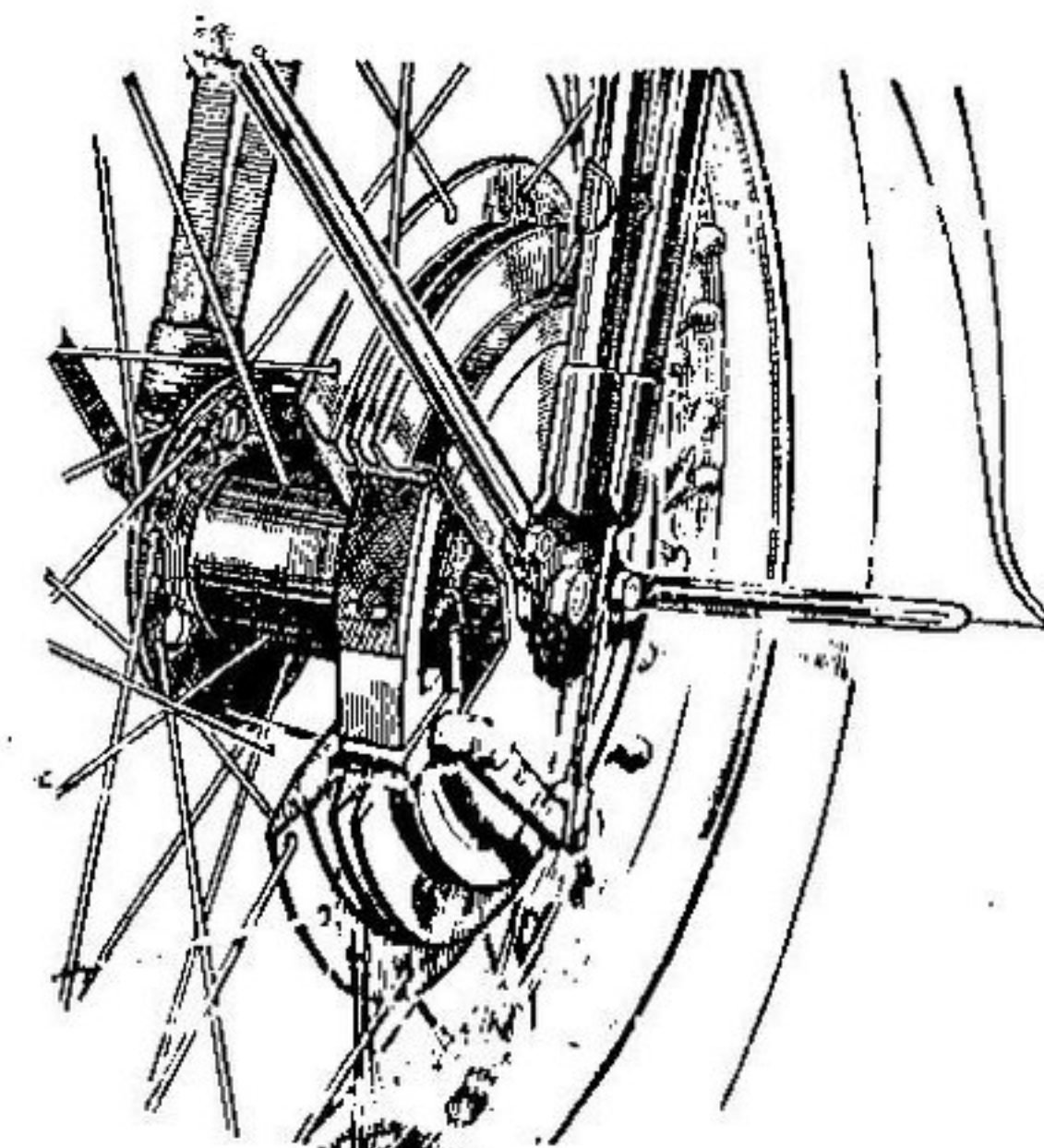

This cutaway view of the highly efficient front brake used on all Models except 35/12, 35/5, 35/11 and 35/4, shows the alloy drum with its cooling fins which serve also to stiffen the drum to prevent distortion, the aluminium alloy brake shoes, and the neat manner in which the operating cable is concealed by passing through the front fork tube, whence it emerges at the finger adjuster shown in the top illustration.

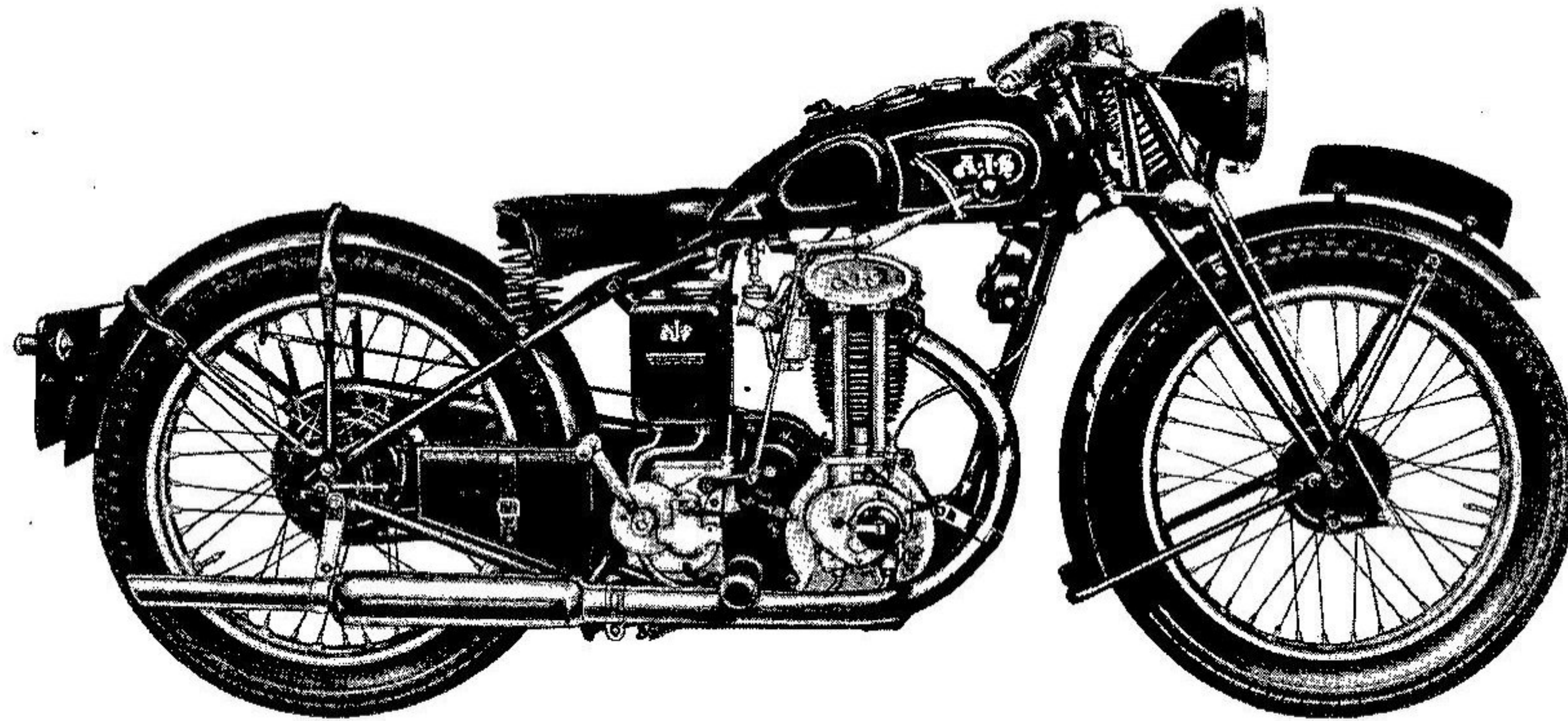

MODEL 35/12—2.46 H.P. SINGLE PORT O.H.V.

SPECIFICATION

ENGINE. Of "A.J.S." manufacture and design. Highly efficient engine with overhead valves, down draught inlet port, enclosed valve and rocker gear, "Lo-ex" alloy piston, roller bearing big end, twin-camshaft timing gear running in oil-bath. All latest improvements embodied to ensure absolute reliability, complete efficiency and high power output. Bore 62.5 mm. Stroke 80 mm. Capacity 246 c.c.

LUBRICATION. Full dry sump system with pressure-type fabric oil filter, which removes all impurities, and can be easily removed for cleaning.

GEARBOX. Four-speed gearbox. Ratios: 6.0, 8.4, 10.75, 17.8 to 1. Entirely enclosed foot-starter mechanism. Hand gear change is standard, but foot change can be fitted at an extra charge of 12/6.

TRANSMISSION. By chain throughout. Front chain running in oil-bath, and rear chain adequately protected by guard having back panel.

CARBURETTER. "Amal" two-lever semi-automatic carburetter. Throttle control operated by twist grip.

EXHAUST SYSTEM. Large diameter exhaust pipe with tubular silencer and tail pipe. A normal low exhaust pipe or upswept competition pipe can be fitted at option.

FRAME. Sturdy duplex loop frame with single down tube.

FRONT FORKS. Centre barrel spring pattern. Shock absorber adjustable by hand.

PETROL TANK. Usual "A.J.S." Black and Gold finish. Flush-fitting instrument panel in top of tank. Capacity 2½ gallons.

OIL TANK. Capacity 3 pints. Quick-action filler cap.

HANDLEBARS. Adjustable semi-sports pattern with controls integral. Finish: Black enamel, with chromium-plated levers.

SADDLE. "Lycett," flexible top, improved three-point mounting.

TYRES. 26 in. x 3.25 in. studded cord tyres.

BRAKES. Internal expanding front and rear, both 5½ in. diameter, fitted with hand adjusters, dust and water excluders. Very powerful and progressive in action.

WHEELS. Wheel rims heavily chromium-plated. Adjustable taper roller bearings to both wheels.

STAND. Easily operated centre stand.

MUDGUARDS. Dome section. Rear, with detachable back portion to facilitate wheel removal.

EQUIPMENT. Full kit of tools, grease gun and tyre inflater.

PRICE:

Including Dynamo-coil electric lighting and ignition set, instrument panel in tank and electric horn,

38 Guineas

When ordering it is essential to state whether high or low exhaust pipe is required. Unless otherwise instructed this machine will be supplied with hand gear change.

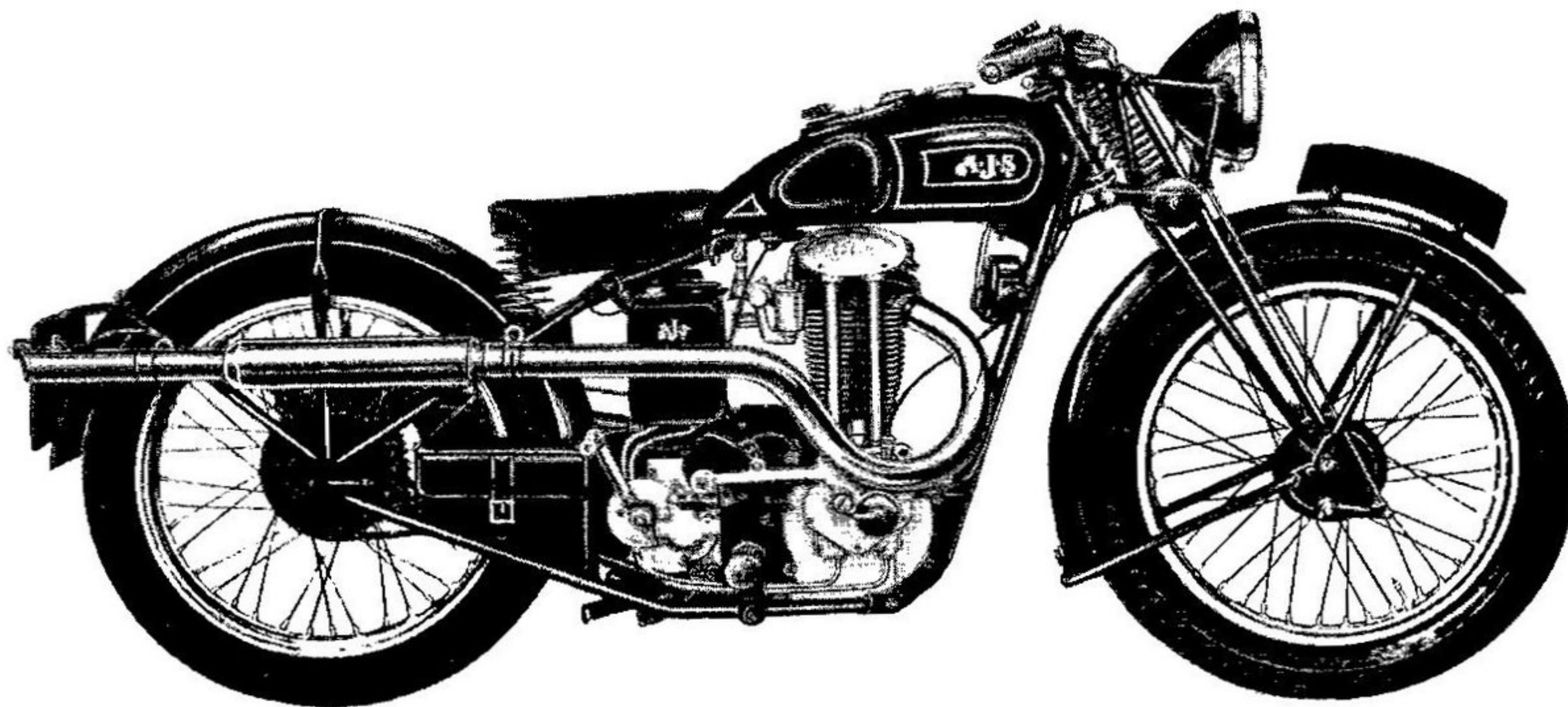

MODEL 35/16—3.47 H.P. SINGLE PORT O.H.V.

SPECIFICATION

ENGINE. Of "A.J.S." design and manufacture. Highly efficient vertical engine with overhead valves. Similar in all respects to the 35/12, but having a larger cubic capacity. Bore 69 mm. Stroke 93 mm. Cubic capacity 347 c.c.

LUBRICATION. Full dry sump system with fabric oil filter.

GEARBOX. Four-speed gearbox. Ratios: 5.32, 7.46, 9.55, 15.81. Completely enclosed foot-starter mechanism. Hand gear change is standard, but foot gear change can be fitted at an extra charge of 12/6.

TRANSMISSION. By chain throughout. Front chain running in oil-bath, and rear chain adequately protected by guard having back panel.

CARBURETTER. "Amal" two-lever, semi-automatic carburetter. Throttle control operated by twist grip.

EXHAUST SYSTEM. Large diameter exhaust pipe with tubular silencer and tail pipe. A normal low exhaust pipe, or upswept competition pipe can be fitted at option.

FRAME. Sturdy duplex loop frame with single down tube.

FRONT FORKS. Centre barrel spring pattern. Hand adjustable shock absorber. Incorporated multi-plate steering damper, also adjustable by hand.

PETROL TANK. Usual "A.J.S." Black and Gold finish. Flush-fitting instrument panel in top of tank. Capacity 2½ gallons.

OIL TANK. Capacity 3 pints. Quick-action filler cap.

HANDLEBARS. Adjustable semi-sports pattern with controls integral. Finish: Black enamel, with chromium-plated levers.

SADDLE. "Lycett," flexible top, improved three-point mounting.

TYRES. Studded Cord, 26 in. x 3.25 in.

BRAKES. Internal expanding front and rear, both 5½ in. diameter, fitted with hand adjusters, water and dust excluders. Very powerful and progressive in action.

WHEELS. Wheel rims heavily chromium-plated. Adjustable taper roller bearings to both wheels.

STAND. Conveniently operated centre stand.

MUDGUARDS. Dome section, rear with detachable back portion to facilitate wheel removal.

EQUIPMENT. Full kit of tools, grease gun and tyre inflator.

PRICE:

Including Dynamo-coil electric lighting and ignition set, instrument panel in tank and electric horn.

£40 Guineas

When ordering it is essential to state whether high or low exhaust pipe is required. Unless otherwise instructed this machine will be supplied with hand gear change.

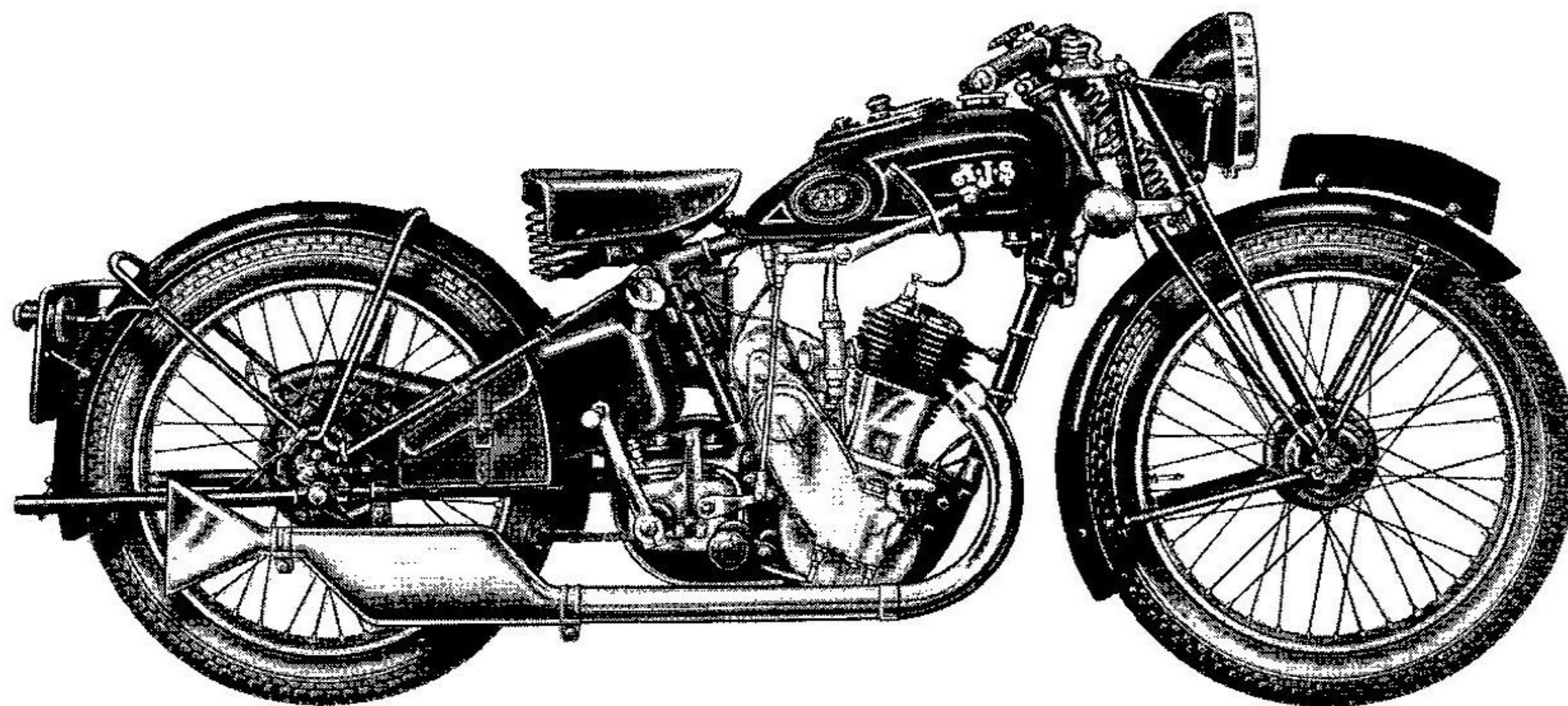

MODEL 35/5 — 3.49 H.P. SIDE VALVE

SPECIFICATION

ENGINE. Of "A.J.S." design and manufacture. Single-cylinder, side-by-side valves. Adjustable mechanical lubrication by gear driven pump integral with magneto chain cover. Aluminium alloy piston with four rings and fully floating gudgeon pin. Roller bearing big end, double row ball bearing to driving side, and single row bearing to timing side shafts. Fully enclosed valve and tappet gear. Inspection disc in magneto chain cover to give easy access to vernier setting device for ignition timing. Bore 74 mm. Stroke 81 mm. Capacity 349 c.c.

GEARBOX. Three-speed gearbox made to "A.J.S." design. Ratios: 5.8, 9 and 16 to 1. Enclosed foot-starter mechanism.

CLUTCH. Single-plate clutch with sensitive hand control. Adjusters on both cable and push rod.

TRANSMISSION. Chain size $\frac{1}{2}$ in. \times .305 in. Front chain completely enclosed in oil-bath chaincase. Rear chain adequately protected by chain guard.

CARBURETTER. "Amal" needle type, with throttle stop and twist grip control.

FRONT FORKS. Centre barrel spring type with hand adjustable shock absorber. Multi-plate steering damper incorporated, also adjustable by hand.

HANDLEBARS. Adjustable semi-sports type, with controls integral. Black enamel finish with chromium-plated levers.

WHEELS. Wheel rims heavily chromium-plated. Adjustable taper roller bearings to both wheels.

TYRES. 25 in. \times 3 in. Studded Cord tyres.

BRAKES. Internal expanding front and rear, both 5 $\frac{1}{2}$ in. diameter, fitted with hand adjusters, water and dust excluders. Very powerful and progressive in action.

SADDLE. "Lycett," flexible top, adjustable in all directions.

FOOTRESTS. Adjustable, affording a wide range of positions.

TANKS. Petrol tank, usual "A.J.S." Black and Gold finish. Capacity 1 $\frac{1}{2}$ gallons. Flush-fitting instrument panel. Oil tank—capacity 3 $\frac{1}{2}$ pints.

EQUIPMENT. Includes full set of tools, grease gun, and tyre inflator.

PRICE:

Including Lucas Magdyno lighting set with instrument panel and electric horn,

£47 - 10 - 0

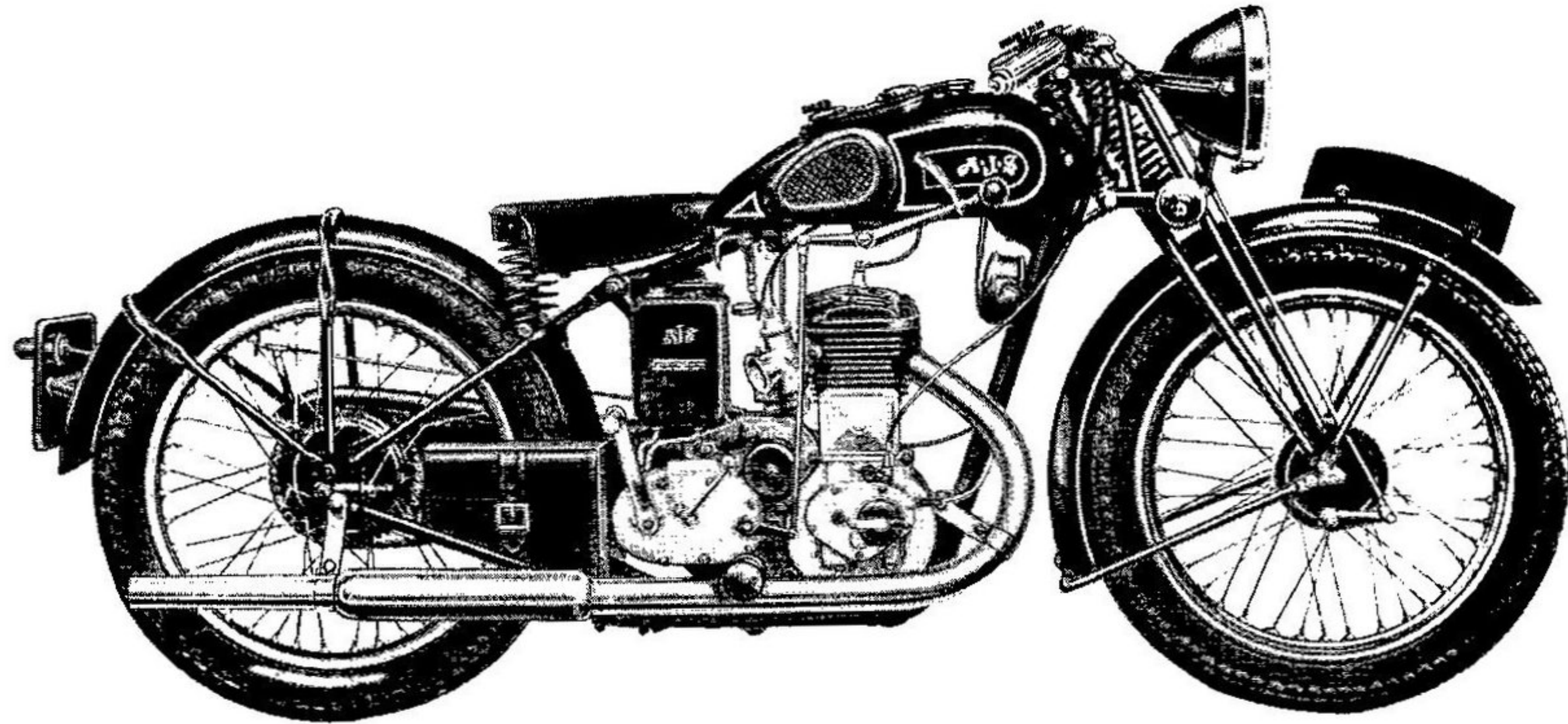

MODEL 35/4 — 4.98 H.P. SIDE VALVE

SPECIFICATION

ENGINE. High-efficiency side-valve engine with Car type detachable cylinder head and latest semi-turbulent combustion space. "Lo-ex" piston, twin-camshaft timing gear. Valves and tappet gear entirely enclosed. Efficient shock absorber on engine shaft. Bore 82.5 mm. Stroke 93 mm. Capacity 498 c.c.

LUBRICATION. Full dry sump system with fabric oil filter.

CARBURETTER. "Amal," feeding engine through latest design "straight-flow" inlet port.

GEARBOX. Heavyweight four-speed gearbox, hand controlled. Gear ratios: 5.1 top, 6.2 third, 8.9 second, 13.6 to 1 bottom.

TRANSMISSION. Oil-bath front chaincase. Rear chain adequately protected by chain guard.

EXHAUST SYSTEM. Large diameter exhaust pipe with tubular silencer and tail pipe.

STANDS. Spring-up centre stand and separate front wheel stand.

TANKS. Petrol tank finished in usual "A.J.S." Black and Gold, with flush-fitting instrument panel. Capacity 2½ gallons. Oil tank—capacity 3 pints.

SPRING FORKS. Centre barrel spring type with hand adjustable shock absorber, steering damper incorporated also adjustable by hand.

WHEELS. Heavily chromium-plated rims, both wheel hubs fitted with adjustable taper roller bearings.

BRAKES. Internal expanding front and rear, both 5½ in. diameter, fitted with hand adjusters, water and dust excluders. Very powerful and progressive in action.

TYRES. 26 in. x 3.25 in. Studded Cord.

MUDGUARDS. Dome section, detachable back portion on rear guard to facilitate wheel removal.

SADDLE. "Lycett" Aero spring seat, three-point suspension.

EQUIPMENT. Includes full set of tools, grease gun and tyre inflator.

PRICE :

Including Dynamo-coil electric lighting and ignition set, instrument panel in tank, and electric horn,

£49 - 10 - 0

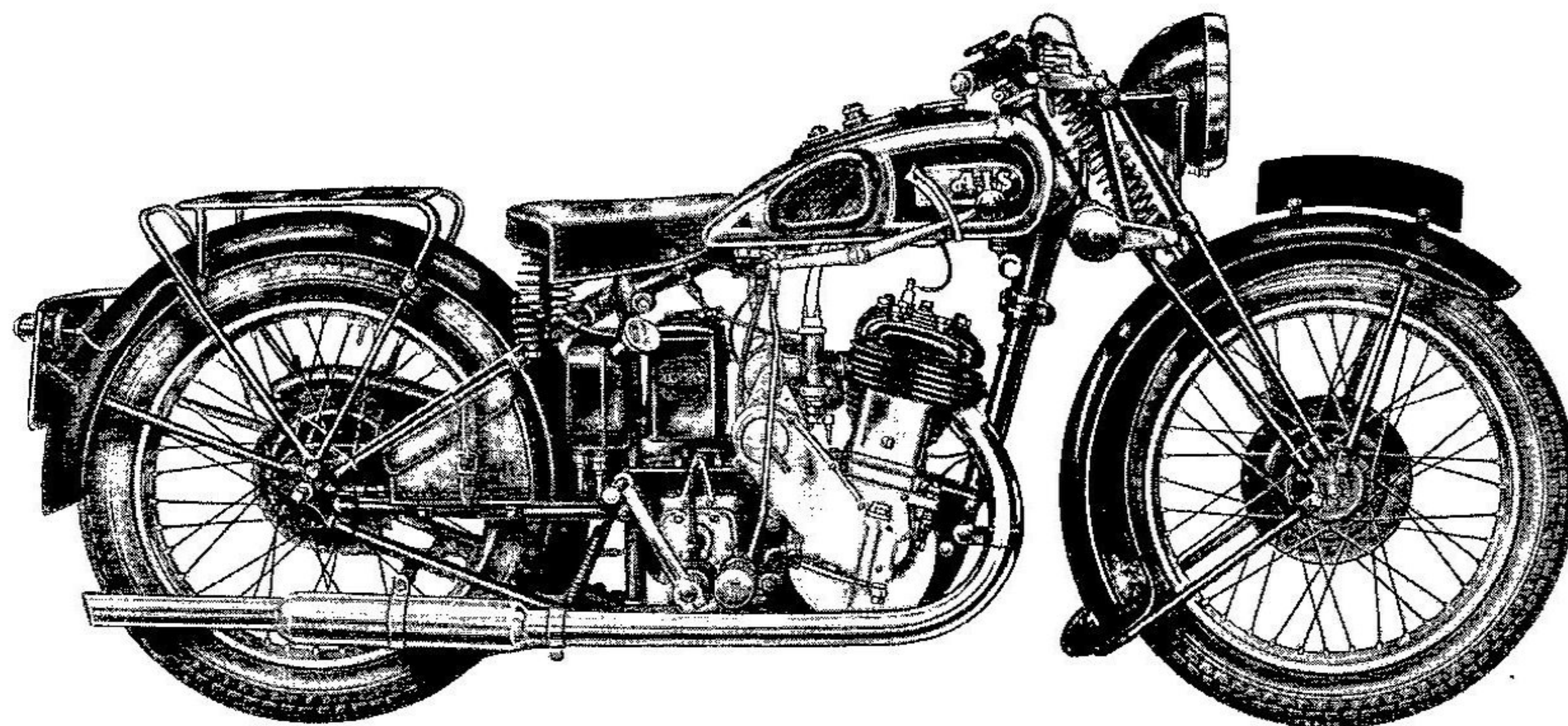

MODEL 35/9 — 4.98 H.P. SIDE VALVE DE LUXE

SPECIFICATION

ENGINE. Of "A.J.S." design and manufacture. Inclined single-cylinder, side-by-side valves. Adjustable mechanical lubrication by gear driven pump integral with magneto chain cover. Detachable aluminium alloy cylinder head, which, when removed leaves the valves *in situ*. Enclosed tappets, valve gear and exhaust valve lifter mechanism. Aluminium alloy piston with fully floating gudgeon pin and four rings. Roller bearing big end, single row ball bearing to timing side mainshaft and double row ball bearing to driving side mainshaft. Inspection disc on magneto chain cover to give easy access to vernier setting device for ignition timing. Bore 84 mm. Stroke 90 mm. Capacity 498 c.c.

GEARBOX. Three-speed constant mesh gearbox made to "A.J.S." design. Ratios: Top 4.81, Second 7.06, Bottom 12.85 to 1. Four-speed gearbox optional at extra charge of £1.0.0.

CLUTCH. Multi-plate clutch, push rod and cable adjusters provided.

FRAME. Semi-cradle with duplex chain stays and torque tubes, sidecar lugs made integral.

FRONT FORKS. Centre barrel spring type, smooth action, adjustable spindles and hand adjustable shock absorbers. With hand adjusted multi-plate steering damper.

HANDLEBARS. Adjustable "clean" type with integral controls, including twist grip and steering damper control knob. Black finish with chromium fittings.

WHEELS. Rear wheel "A.J.S." patent, quickly detachable, with locking device on sleeve bolts. Adjustable taper roller bearings to both wheel hubs. Rims chromium-plated.

TYRES. 26 in. x 3.25 in. Studded Cord.

MUDGUARDS. Rear hinged for quick wheel removal. Front fully valanced.

CARBURETTER. "Amal" needle type with throttle stop and pilot jet.

FOOTRESTS. Footrest arms adjustable to wide range of positions, rubber covered and of sturdy design.

BRAKES. Both 7 in. diameter, brake drums of special iron alloy, front with cooling fins. Both fitted with dust and water excluders and finger adjustment.

TRANSMISSION. "Renold" chain, primary $\frac{1}{2}$ in. x .305 in. running in oil-bath. Efficient shock absorber fitted to engine shaft, also running in oil. Rear chain "Renold" $\frac{3}{8}$ in. x $\frac{3}{8}$ in. fitted with top half chain cover.

SADDLE. "Lycett" soft top with three-point suspension, adjustable backwards and forwards.

STANDS. Central spring-up. Front tubular steel bolted to front mudguard.

PETROL TANK. Chromium-plated and black finish, with flush-fitting instrument panel. Capacity 2½ gallons. Quick-action filler cap.

OIL TANK. Capacity 4½ pints. Quick-action filler cap.

REAR CARRIER. Detachable, made of welded steel tubing.

EQUIPMENT. Full kit of tools, grease gun and tyre inflator.

PRICE:

Including Lucas Magdyno electric lighting set, instrument panel in tank and Lucas electric horn,

£56 - 2 - 6

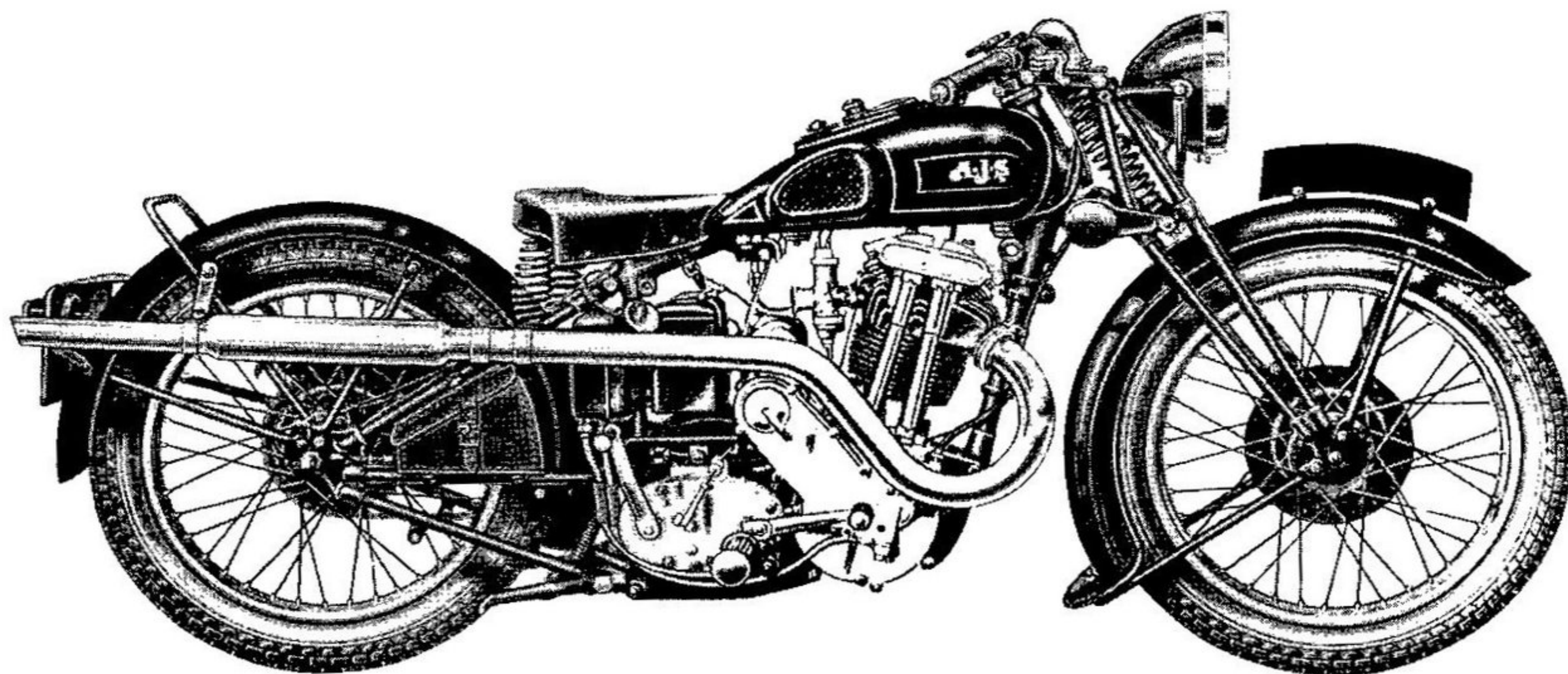

MODEL 35/18—4.98 H.P. SINGLE PORT O.H.V.

SPECIFICATION

ENGINE. Of "A.J.S." design and manufacture. Single-cylinder with overhead valves. Adjustable mechanical lubrication by gear driven pump integral with magneto chain cover. Compression ratio 6 to 1. Single-port cylinder head. Duralumin rocker arms, tappet tubes and small end bush. Roller bearing big ends, single row ball bearing to timing side, and double row ball bearing to driving side mainshaft. Totally enclosed rocker gear and tappet tubes. Vernier setting device for ignition timing. Bore 84 mm. Stroke 90 mm. Capacity 498 c.c.

GEARBOX. Four-speed gear made to "A.J.S." design. Ratios: 5, 6.3, 7.85 and 13.25 to 1. Hand or foot control optional.

CLUTCH. Multi-plate clutch, finger-operated cable adjuster provided.

FRAME. Semi-cradle, with duplex chain stays and torque tubes, sidecar lugs made integral.

FRONT FORKS. Centre barrel spring type, smooth action, adjustable spindles, and hand adjustable shock absorber. With hand adjusted multi-plate steering damper.

HANDLEBARS. Adjustable "clean" type with integral controls, including twist grip and steering damper control knob. Black finish with chromium fittings.

EXHAUST SYSTEM. With normal downswept exhaust pipe, round type silencer and tail pipe. Upswept competition pipe at option.

WHEELS. Rear wheel—"A.J.S." patent, quickly detachable with locking device on sleeve bolts. Adjustable taper roller bearings to both wheel hubs, chromium-plated rims.

TYRES. 26 in. x 3.25 in. Studded Cord.

MUDGUARDS. Rear hinged for quick wheel removal. Front fully valanced.

CARBURETTER. "Amal" needle type with throttle stop and pilot jet.

FOOTRESTS. Footrest arms adjustable to wide range of positions, rubber covered and of sturdy design.

BRAKES. Both 7 in. diameter. Brake drums of special iron alloy, front with cooling fins. Both fitted with dust and water excluders and finger adjustment.

TRANSMISSION. "Renold" chain, primary $\frac{1}{2}$ in. x .305 in. running in oil-bath. Efficient shock absorber, fitted to engine shaft, also running in oil. Rear chain "Renold" $\frac{5}{8}$ in. x $\frac{3}{8}$ in. fitted with efficient top half chain cover.

SADDLE. "Lycett" soft top with three-point suspension, adjustable backwards and forwards.

STANDS. Centre spring-up. Front—tubular steel bolted to front mudguard.

PETROL TANK. Finished in Black and Gold, with flush-fitting instrument panel. Quick-action filler cap. Capacity 2 $\frac{1}{2}$ gallons.

OIL TANK. Capacity 4 $\frac{1}{2}$ pints. Quick-action filler cap.

EQUIPMENT. Full kit of tools, grease gun and tyre inflator.

PRICE:

Including Lucas Magdyno electric lighting set, instrument panel in tank and Lucas electric horn,

£57 - 10 - 0

When ordering it is essential to state whether high or low exhaust pipe is required. Unless otherwise instructed this machine will be supplied with hand gear change.

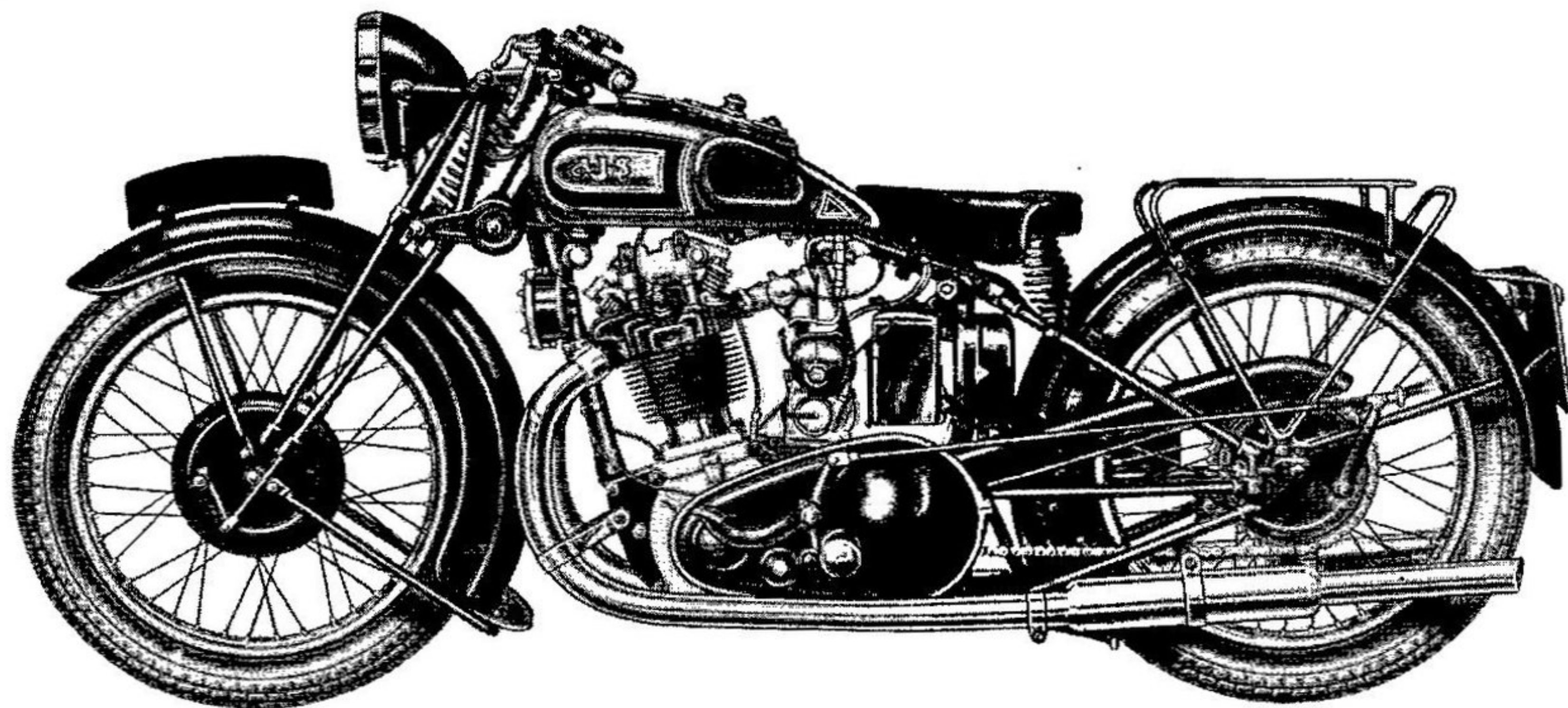

**MODEL 35/6 — 3.49 H.P. TWO-PORT DE LUXE O.H.V.
AND
MODEL 35/8 — 4.98 H.P. TWO-PORT DE LUXE O.H.V.**

SPECIFICATION

ENGINE. Of "A.J.S." design and manufacture. Inclined single-cylinder with overhead valves. Adjustable mechanical lubrication by gear driven pump integral with magneto chain cover. Down-draught Inlet port on Model 35/8. Two-port detachable cylinder head, duplex valve springs. Duralumin rocker arms, tappet tubes and small end bush. Aluminium alloy piston with fully floating gudgeon pin and four rings. Roller bearing big end, single row ball bearing to timing side mainshaft and double row ball bearing to driving side mainshaft. Totally enclosed rocker gear, tappet tubes and exhaust valve lifter mechanism. Inspection disc on magneto chain cover giving easy access to vernier setting device for ignition timing.
Model 35/6: Bore 74 mm. Stroke 81 mm. Capacity 349 c.c.
Model 35/8: Bore 84 mm. Stroke 90 mm. Capacity 498 c.c.

GEARBOX. Four-speed gear made to "A.J.S." design, with totally enclosed foot-starter mechanism and speedometer drive.
Ratios—Model 35/6: 5.8, 7.0, 12.6 and 17.4 to 1.
Model 35/8: 5, 6.9, 8.8 and 13.35 to 1.
Hand or foot control optional.

CLUTCH. Multi-plate clutch; accessible cable adjuster provided.

FRAME. Semi-cradle with duplex chain stays and torque tubes. Sidecar lugs made integral.

FRONT FORKS. Centre barrel spring type, smooth action, adjustable spindles and hand adjustable shock absorber. With hand adjusted, multi-plate steering damper.

HANDLEBARS. Adjustable "clean" type with integral controls, including twist grip and steering damper control knob. Black finish with chromium fittings.

EXHAUST SYSTEM. With normal low exhaust pipes and round type silencers. Upswept competition pipes supplied at option.

WHEELS. Rear wheel "A.J.S." patent, quickly detachable, with locking device on sleeve bolts. Adjustable taper roller bearings to both wheel hubs. Chromium-plated rims.

TYRES. 26 in. x 3.25 in. Studded Cord.

MUDGUARDS. Rear hinged for quick wheel removal. Front fully valanced.

CARBURETTER. "Amal" needle type with throttle stop and pilot jet. On Model 35/8 the carburetter has a horizontal mixing chamber.

FOOTRESTS. Footrest arms adjustable to wide range of positions, rubber covered and of sturdy design.

BRAKES. Both 7 in. diameter, brake drums of special iron alloy, front with cooling fins. Both fitted with dust and water excluders and finger adjustment.

TRANSMISSION. "Renold" chain, primary $\frac{1}{2}$ in. x .305 in. running in oil-bath. Efficient shock absorber fitted to engine shaft, also running in oil. Rear chain "Renold" $\frac{1}{2}$ in. x .305 in. on Model 35/6 and $\frac{3}{8}$ in. x $\frac{3}{8}$ in. on Model 35/8, fitted with efficient top half chain cover.

SADDLE. "Lycett" soft top with three-point suspension, adjustable backwards and forwards.

STANDS. Central spring-up. Front—tubular steel bolted to front mudguard.

PETROL TANK. Chromium-plated and Black finish with flush-fitting instrument panel. Capacity $2\frac{1}{2}$ gallons. Quick-action filler cap.

OIL TANK. Capacity $4\frac{1}{2}$ pints. Quick-action filler cap.

REAR CARRIER. Detachable, made of welded steel tubing.

EQUIPMENT. Full kit of tools, grease gun and tyre inflator.

PRICE:

MODEL 35/6. Including Lucas Magdyno electric lighting set, instrument panel in tank and Lucas electric horn,

£57 - 10 - 0

MODEL 35/8. Including Lucas Magdyno electric lighting set, instrument panel in tank and Lucas electric horn,

£62 - 10 - 0

When ordering it is essential to state whether high or low exhaust pipes are required. Unless otherwise instructed these machines will be supplied with hand gear change.

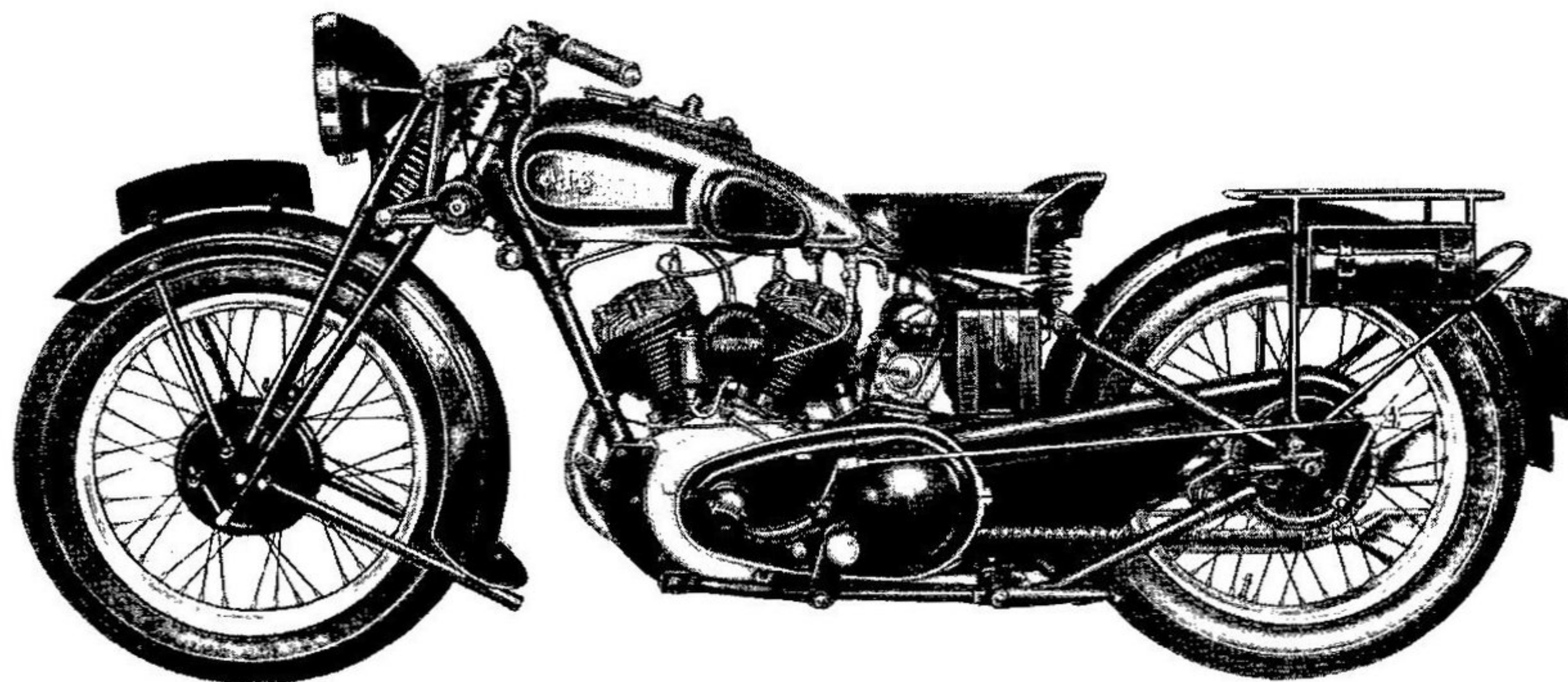

ENGLISH MODEL 35/2—9.9 H.P. S.V. TWIN

SPECIFICATION

ENGINE. High-efficiency 50-degree twin-cylinder 9.9 h.p., with detachable cylinder heads, which, when removed leave the valves *in situ*. Anti-slap lightweight "Lo-ex" alloy pistons, roller bearing big ends, and improved crankshaft assembly and engine shock absorber. Tappets and valve gear totally enclosed and lubricated, timing gears submerged in oil. Bore 85.5 mm. Stroke 85.5 mm. Capacity 990 c.c.

LUBRICATION. Thoroughly tested dry-sump system, incorporating pressure type fabric oil filter, ensuring the removal of all impurities from the oil in circulation.

GEARBOX. Four-speed pivot-mounted to "A.J.S." design. Hand control standard. Foot control can be fitted at an extra charge of 15/-.

CLUTCH. Multi-plate with ferodo and cork inserts. Finger-operated cable adjuster provided, hand control with light tension.

FRAME. Cradle-type with low saddle position and sidecar lugs made integral, and various improvements including greater tyre and chain clearances.

SPRING FORKS. Centre barrel spring type with long movement and adjustable spindles, hand adjustable shock absorber.

BRAKES. Internal expanding front and rear. Front 7 in. diameter with special iron alloy drum with cooling fins. Rear 7½ in. diameter. Both are fitted with dust and water excluders and finger adjustment. Front—hand operated. Rear—foot operated.

CARBURETTER. "Amal" needle type with pilot jet and throttle stop, large "Amal" air filter.

REAR CARRIER. Welded tubular steel with quickly detachable top. Two pannier bags provided.

TANKS. Chromium-plated petrol tank with usual "A.J.S." Black and Gold design. Flush-fitting instrument panel mounted on top of the tank, containing switches, ammeter and provision for watch. Capacity 3½ gallons. A separate oil tank with accessible filler cap is mounted under the saddle. Capacity approximately 5 pints.

TRANSMISSION. Front chain size ½ in. × .305 in. running in oil-bath. Rear chain size ⅝ in. × ⅝ in. with top and back chain cover.

WHEELS. Well-known patent "A.J.S." quickly detachable and interchangeable wheels front and rear, special locking device for sleeve bolts. Extra heavy 19 in. × 3 in. 14-gauge rims, with 6-9 gauge butted spokes, giving enormous strength. Chromium-plated rims.

TYRES. Heavy duty 27 in. × 4 in. Cord tyres.

MUDGUARDS. Deeply valanced front mudguard, wide section giving ample tyre clearance. Rear mudguard detachable for easy wheel removal.

HANDLEBARS. Semi-sports "clean" type, black enamel with chromium-plated levers.

SADDLE. Comfortable pan seat with three-point suspension, hinged at the front and long springs at the rear affording great comfort.

STEERING DAMPER. Control knob conveniently situated on steering head. Duplex plates with large frictional surfaces and rigid anchorage eliminating back lash.

EQUIPMENT. Full kit of tools, grease gun and tyre inflator.

PRICE:

Including Lucas Magdyno electric lighting set, instrument panel in tank and Lucas electric horn,

£72 - 15 - 0

Unless otherwise instructed this machine will be supplied with hand gear change.

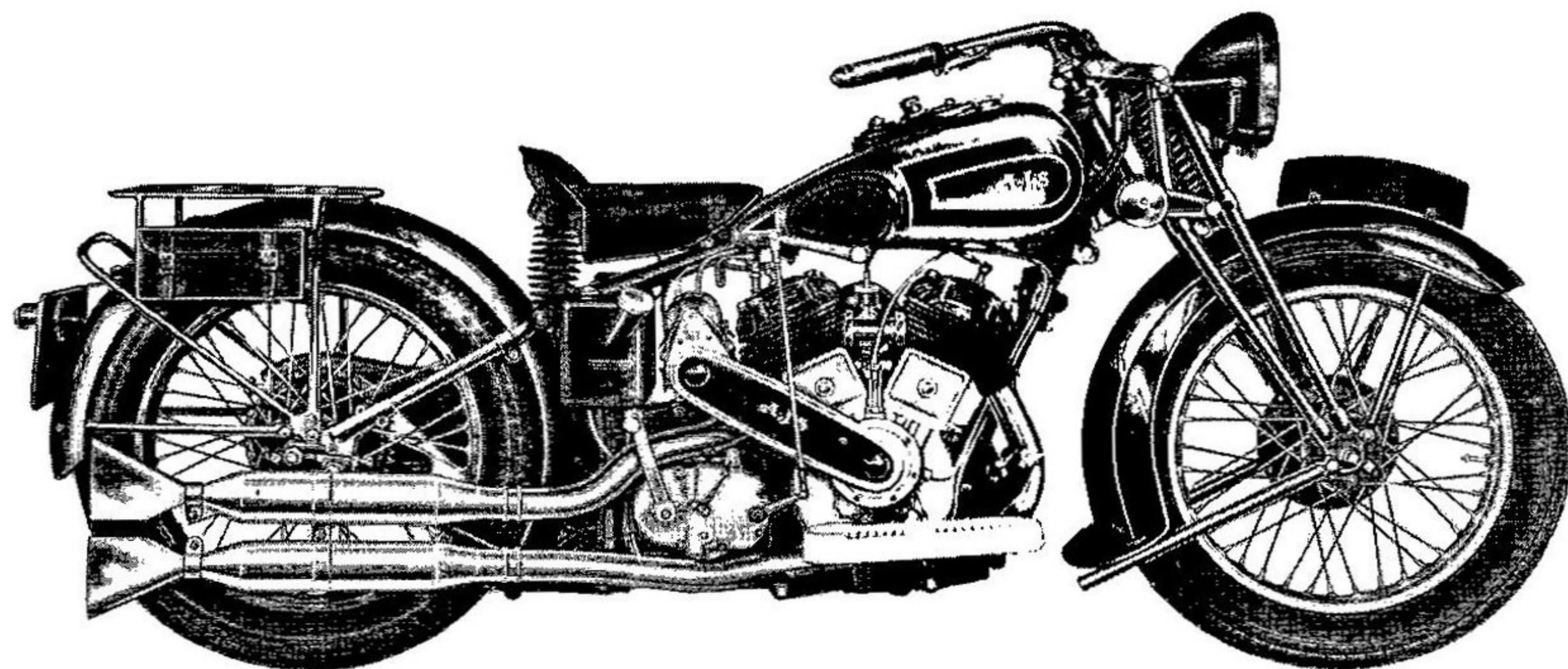

EXPORT MODEL 35/2—9.9 H.P. S.V. TWIN

SPECIFICATION

ENGINE. High-efficiency 50-degree twin-cylinder 9.9 h.p., with detachable cylinder heads, which, when removed leave the valves *in situ*. Anti-slap light-weight "Lo-ex" alloy pistons, roller bearing big ends, and improved crankshaft assembly and engine shock absorber. Tappets and valve gear totally enclosed and lubricated, timing gears submerged in oil. Bore 85.5 mm. Stroke 85.5 mm. Capacity 990 c.c.

LUBRICATION. Thoroughly tested dry-sump system, incorporating pressure type fabric filter, ensuring the removal of all impurities from the oil in circulation.

GEARBOX. Four-speed pivot-mounted made to "A.J.S." design, gear quadrant in convenient position on left side of petrol tank. As an alternative a three-speed gearbox with reverse gear can be fitted at an extra charge of £2.10.0.

CLUTCH. Multi-plate clutch with ferodo and cork inserts, finger-operated cable adjuster provided. Controlled by pedal on left-hand side of machine.

FRAME. Cradle-type with low saddle position and sidecar lugs made integral, and various improvements including greater tyre and chain clearances.

SPRING FORKS. Centre barrel spring type with long movement and adjustable spindles, hand adjustable shock absorber.

BRAKES. Internal expanding front and rear. Front 7 in. diameter with special iron alloy drum with cooling fins. Rear 7½ in. diameter. Both are fitted with dust and water excluders and finger adjustment. Front brake—hand operated. Rear—foot operated, with ratchet locking device on pedal.

CARBURETTOR. "Amal" needle type with pilot jet and throttle stop, large "Amal" air filter.

REAR CARRIER. Welded tubular steel with quickly detachable top. Two pannier bags provided.

TANKS. Chromium-plated petrol tank with usual "A.J.S." Black and Gold design. Flush-fitting instrument panel mounted on top of the tank, containing switches, ammeter and provision for watch. Capacity 3½ gallons. A separate oil tank with accessible filler cap is mounted under the saddle. Capacity approximately 5 pints.

TRANSMISSION. Front chain ½ in. × .305 in. running in oil-bath. Rear chain ⅝ in. × ⅝ in. with top and back chain cover.

WHEELS. Well-known "A.J.S." patent quickly detachable and interchangeable wheels front and rear, special locking device for sleeve bolts. Extra heavy 19 in. × 3 in. 14-gauge rims chromium-plated, with 6-9 gauge butted spokes, giving enormous strength.

TYRES. Heavy duty 27 in. × 4 in. Cord tyres.

MUDGUARDS. Deeply valanced front mudguard, wide section giving ample tyre clearance. Rear mudguard detachable for easy wheel removal.

HANDLEBARS. Long comfortable touring handlebars with twist grip control.

FOOTBOARDS. Thick rubber covered footboards with control pedals conveniently placed.

SADDLE. Comfortable pan seat with three-point suspension, hinged at the front and long springs at the rear affording great comfort.

STEERING DAMPER. Control knob conveniently situated on steering head. Duplex plates with large frictional surfaces and rigid anchorage eliminating back lash.

EQUIPMENT. Full kit of tools, grease gun and tyre inflator.

PRICE:

Including Lucas Magdyno electric lighting set, instrument panel in tank and Lucas electric horn,

£72 - 15 - 0

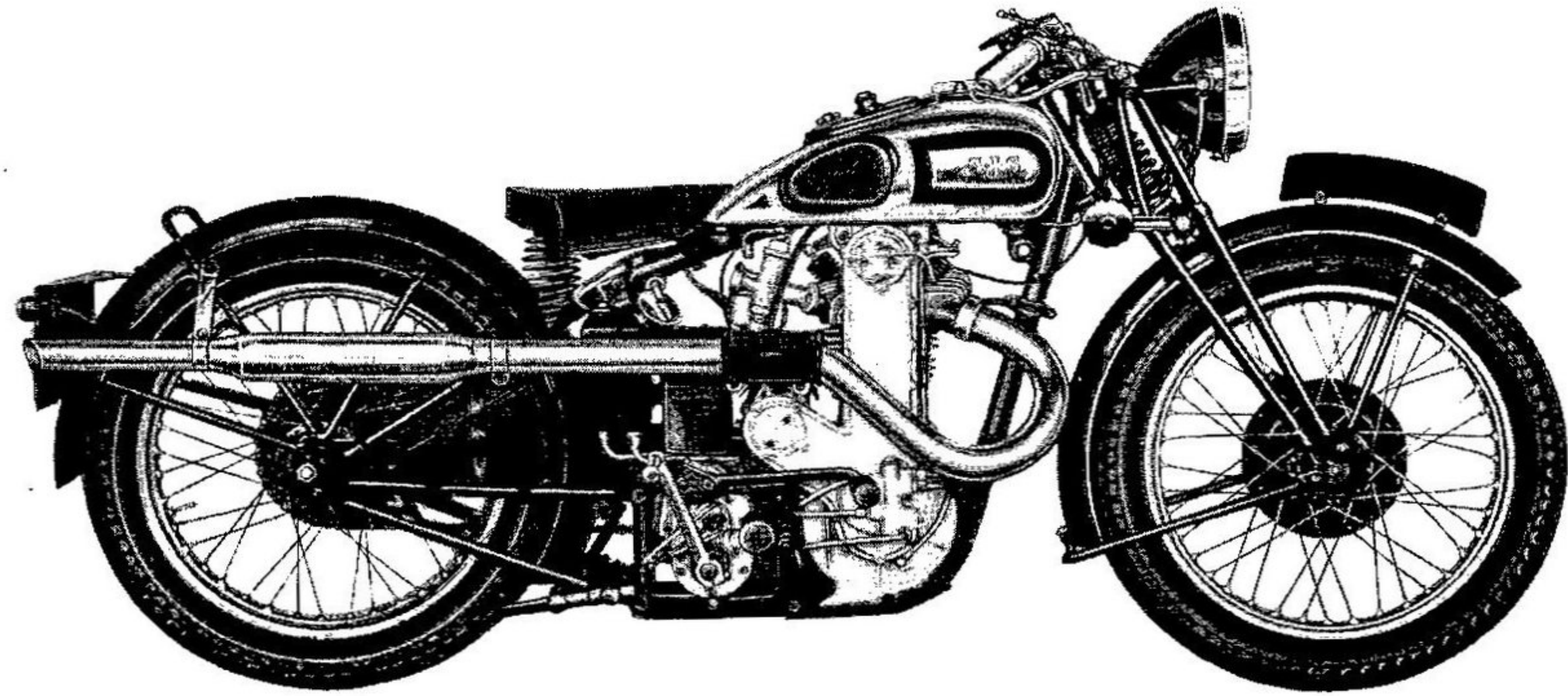

35/7 — 3.46 H.P. CAMSHAFT 'TROPHY' COMPETITION AND RACING MODELS

SPECIFICATION

ENGINE. Famous overhead-camshaft "A.J.S." engine with detachable cylinder head with down-draught inlet port and single exhaust port. Specially designed aluminium alloy piston with fully floating gudgeon pin and three narrow rings. Connecting rod, O.H.C. rockers, etc., machined from special steel. Roller bearing big end, and ball bearings to both timing and driving side mainshafts. The camshaft is driven by roller chain with patented tensioning device and re-action damper. Interior surfaces of the engine are specially finished and highly polished. The piston fitted as standard gives a compression ratio of 6 to 1. Pistons giving ratios of 7.5 and 11 to 1 are available. Vernier setting device for ignition timing. Bore 70 mm. Stroke 90 mm. Capacity 346 c.c.

LUBRICATION. Dry sump system is employed and a fabric filter is included in this, ensuring the removal of all impurities from the oil in circulation. Separate feeds are also taken to the cylinder base, valve guides and camshaft housing, which has its own scavenging pump.

GEARBOX. Four-speed with positive stop foot gear change on offside of machine. No kickstarter on Racing Model.

Competition Model, Ratios: Top 5.37, Third 6.49, Second 9.50, Bottom 15.95;
Racing Model, Ratios: Top 5.7, Third 6.49, Second 7.84, Bottom 13.8.

CLUTCH. Multi-plate clutch with push rod and cable adjusters.

WHEELS. Both wheels fitted with taper roller bearings, rear wheel specially reinforced with 14-gauge rim and 6-9 gauge butted spokes. The rear wheel is of the quickly detachable type. Chromium-plated wheel rims.

TYRES. 26 in. x 3.25 in. Cord tyres on "Competition" Models. 26 in. x 3 in. front ribbed and 26 in. x 3.25 in. rear studded on "Racing" Models.

MUDGUARDS. Of unvalanced "Sports" pattern.

BRAKES. Front and rear internal expanding, both finger adjusted. Rear brake 7½ in. diameter, operated by pedal on left side of machine. Front brake 7 in. diameter, with special iron alloy drum with stiffening ribs.

HANDLEBARS. Latest type with adjustable bolt-on controls. Black finish with chromium fittings.

FORKS. "A.J.S." design with centre barrel spring and re-action damper springs. Fitted with hand adjusted shock absorber and multi-plate steering damper.

STANDS. Centre spring-up stand. Sturdy front stand bolted into position on front mudguard.

FRAME. Semi-duplex type with triple rear fork members ensuring absolute rigidity at high speeds.

TANKS. Petrol tank on Competition Model—capacity approximately 2 gallons. Finished in the usual "A.J.S." style with Black and Gold panels on chromium. Racing Model—capacity 3½ gallons, finished in Black and Gold. Oil tank—capacity 5 pints. Situated behind the saddle down tube and fitted with quick-action hinged filler cap.

CARBURETTER. "Amal" large bore needle type carburetter with throttle stop and quick-action twist grip on Competition Model. "Amal" Racing type carburetter fitted to Racing Model.

IGNITION. Lucas racing magneto or racing magdyno with detachable dynamo portion, usual handlebar ignition lever control.

CHAINS. "Renold" front ½ in. x .305 in. running in oil-bath. Rear chain ½ in. x ⅝ in. with ordinary top half chain cover for accessibility.

EXHAUST SYSTEM. Upswept with round type silencer on Competition Model. Straight-through exhaust pipe without silencer on Racing Model. Low or upswept pipes supplied optional.

TOOL-BOX AND EQUIPMENT. Metal covered, lined tool-box carried between rear chain stays, comprehensive set of tools, grease gun and tyre inflator.

NOTE.—Illustration shows Competition Model. Racing Model is, except for engine, similar in appearance to Model 35/10 illustrated on page 13.

PRICE:

To standard specification without electrical equipment.

COMPETITION MODEL—

£65 - 0 - 0

RACING MODEL—

£70 - 0 - 0

For prices of Electric Lighting see page 16.

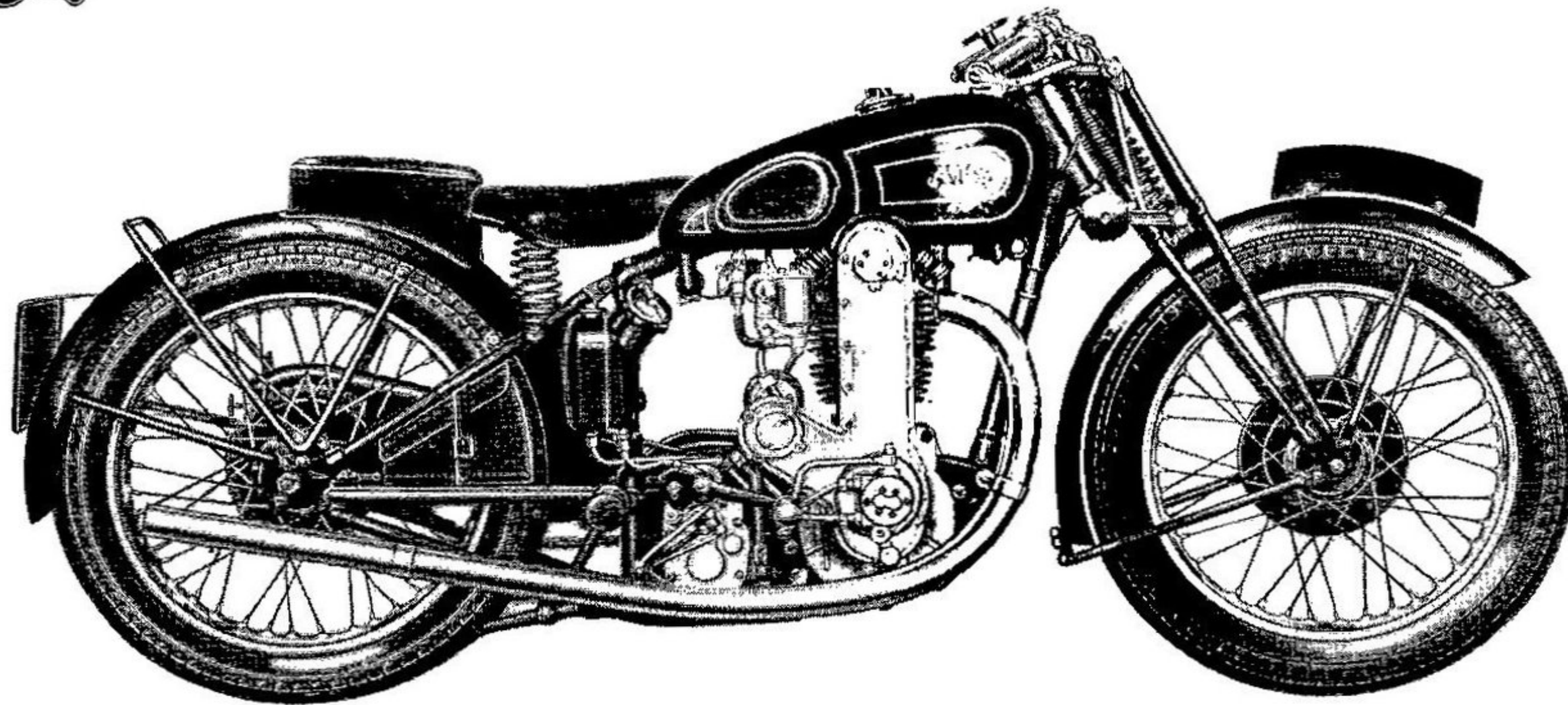

35/10 — 4.95 H.P. CAMSHAFT 'TROPHY' COMPETITION AND RACING MODELS

SPECIFICATION

ENGINE. "A.J.S." high-efficiency overhead-camshaft engine of the very latest design, identical throughout with the engines used in the "A.J.S." machines competing in the Isle of Man Tourist Trophy Senior Race in 1934. The high speed reliability of this engine is proved by the fact that in that race the "A.J.S." team of three machines was the only make to gain 100 per cent. success, all three "A.J.S." machines entered gaining "Trophy" replicas.

This engine has been specially designed and built throughout to give the highest possible efficiency and maximum power output. All internal parts are exceedingly massive. Details include three-row roller big end bearing, two-row ball bearing to driving side mainshaft, ball bearing on timing side mainshaft. Cylinder head and ports of the latest design, down-draught inlet port, "Hairpin" valve springs, exceptionally complete lubrication system with large gear pump mounted in timing case feeding under pressure to big end, piston and camshaft housing. Adjustable feed to cylinder wall. A special exhausting pump is fitted to the camshaft chain cover to remove excess oil from the camshaft housing and so prevent leakage. The lubrication operates on the true dry-sump system, the pump feeding large quantities of oil, excess being sucked out of the sump at the bottom of the crankcase and returned by a second gear pump from the sump to the oil tank. Completeness with which the lubrication system is worked out is shown by the fact that even the valve guides are fed with oil through small sumps at the bottom of the camshaft housing.

On Racing Models the whole of the interior of the engine is highly polished, including flywheels, connecting rod, cylinder head and ports. Standard compression ratio: Competition Model 6 to 1; Racing Model 7.5 to 1, and 11 to 1 piston is also available for use with alcohol fuel.

GEARBOX. Four-speed with positive stop foot change on offside of machine. No kickstarter on Racing Model.

Competition Model, Ratios: 4.7 top, 5.68 third, 8.32 second, 13.95 to 1 bottom; **Racing Model, Ratios:** 4.7 top, 5.68 third, 6.86 second, 12.08 bottom.

CLUTCH. Multi-plate clutch with push rod and cable adjusters.
WHEELS. Both wheels fitted with taper roller bearings. Rear wheel specially reinforced with 14-gauge rim and 6-9 gauge butted spokes. The rear wheel is of the quickly detachable type. Chromium-plated wheel rims.

TYRES. 26 in. x 3.25 in. Cord tyres on Competition Model. 26 in. x 3 in. front ribbed and 26 in. x 3.25 in. rear studded on Racing Models.

MUDGUARDS. Of unvalanced "Sports" pattern.

BRAKES. Front and rear internal expanding, both finger adjusted. Rear brake 7 7/8 in. diameter. Front brake 7 in. diameter, with special iron alloy drum with stiffening ribs.

HANDLEBARS. Latest type with adjustable bolt-on controls.

FORKS. "A.J.S." design with centre barrel spring and re-action damper springs. Fitted with hand adjusted shock absorber and multi-plate steering damper.

STANDS. Centre spring-up stand. Sturdy front stand bolted into position on front mudguard.

FRAME. Semi-duplex type with triple rear fork members ensuring absolute rigidity at high speeds.

TANKS. Petrol tank on Competition Model—capacity approximately 2 gallons. Finished in the usual "A.J.S." style with Black and Gold panels on chromium. Racing Model—capacity 3 1/2 gallons, finished in Black and Gold. Oil tank—capacity 5 pints. Situated behind the saddle down tube and fitted with quick-action hinged filler cap.

CARBURETTER. "Amal" large bore needle type carburetter with throttle stop and quick-action twist grip on Competition Model. "Amal" Racing type carburetter fitted to Racing Model.

IGNITION. Lucas racing magneto or racing magdyno with detachable dynamo portion, usual handlebar ignition lever control.

CHAINS. "Renold" front 1/2 in. x .305 in. running in oil-bath. Rear chain 5/8 in. x 3/8 in.

EXHAUST SYSTEM. Upswept with round type silencer on Competition Model. Straight-through exhaust pipe without silencer on Racing Model. Low or upswept pipes supplied optional.

TOOL-BOX AND EQUIPMENT. Metal covered, lined tool-box carried between rear chain stays, comprehensive set of tools, grease gun and tyre inflator.

NOTE.—Illustration shows Racing Model. Competition Model is, except for engine, similar in appearance to Model 35/7 illustrated on page 12.

PRICE :

To standard specification without lighting.

COMPETITION MODEL—

£75 - 0 - 0

RACING MODEL—

£80 - 0 - 0

For prices of Electric Lighting see page 16.

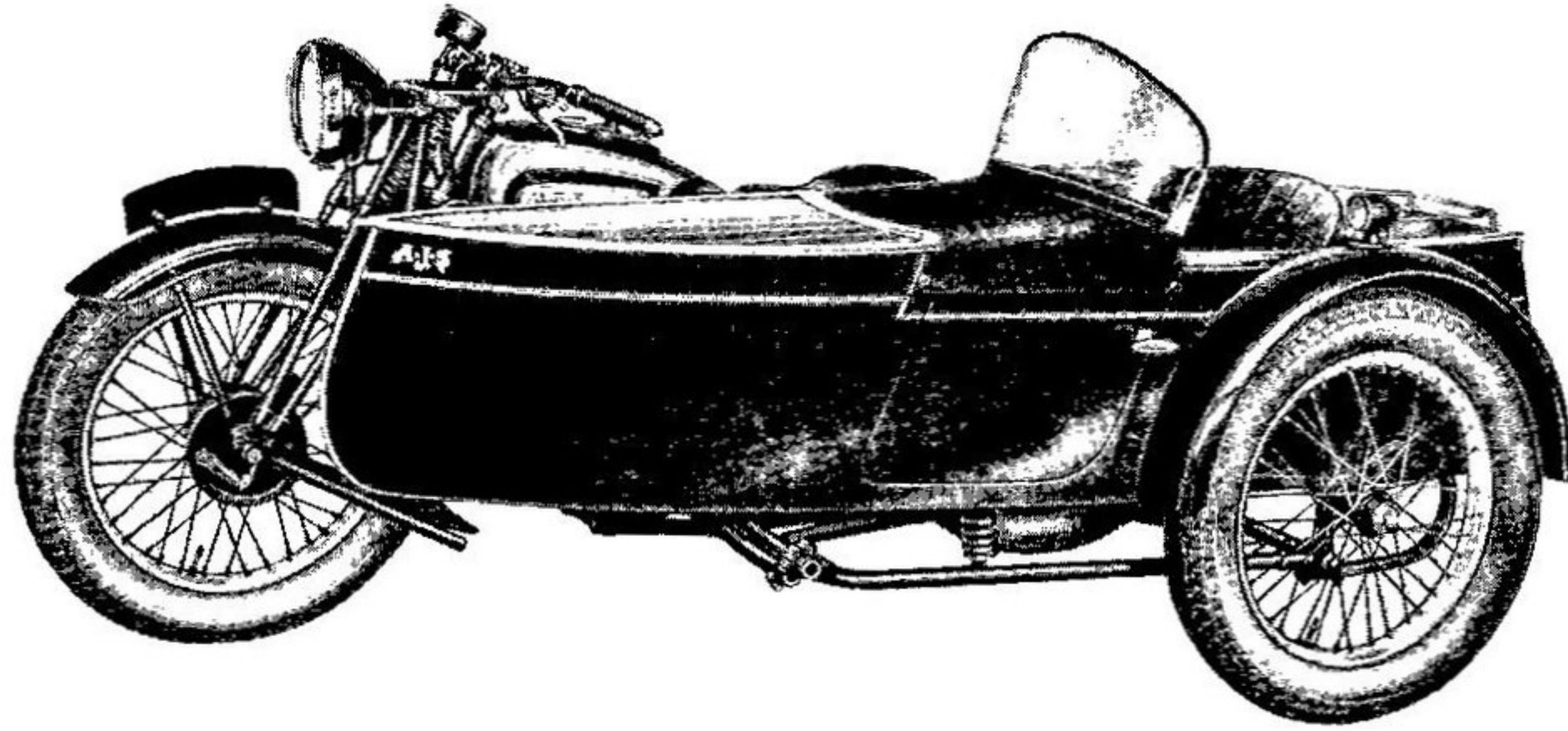

MODEL "B" SIDECAR

The most attractive sidecar which has ever been produced. Finished in Black and Chromium, with broad Chromium deck strips. There is ample leg room even for the tallest of passengers. Chromium-plated rail fitted to rear deck. Windscreen and Electric Lamp included in specification. Suitable for Models 35/6, 35/18, 35/8, 35/9 and 35/2.

Price—on Stub axle chassis **£17 - 15 - 0**

Price—on Special chassis with quick detachable wheel interchangeable with wheels of 35/2 **£19 - 5 - 0**

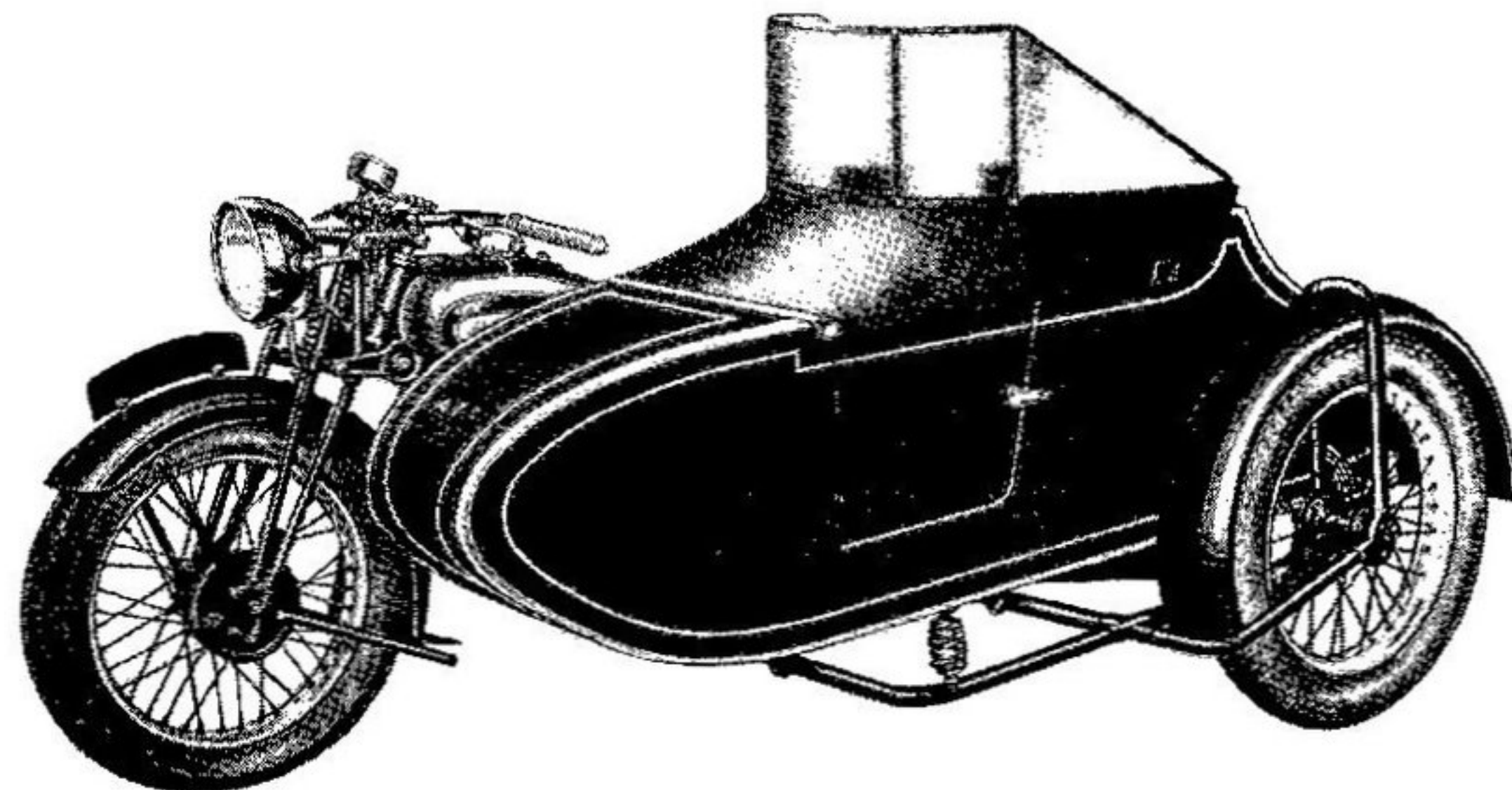

MODEL "D" SIDECAR

This sidecar presents an entirely new design in Sports-Tourist Models. It is finished in Mottled Aluminium and all fittings are heavily Chromium-plated. Note the sloping tail to which is fitted a large luggage grid. Suitable for use with Models 35/6, 35/18, 35/8, 35/9 and 35/2.

Price—on Stub axle chassis **£23 - 0 - 0**

Price—on Special chassis with quick detachable wheel interchangeable with wheels of 35/2. **£25 - 0 - 0**

MODEL "C" SIDECAR

Although this is generally termed an "Occasional Two-Seater" there is sufficient room in the seats to accommodate two adults in comfort. When only one passenger is carried the back can be closed, which gives the impression that the body is of the luxurious single-seater type. Extremely well sprung and upholstered. Windscreen and electric lamp included. This sidecar is only suitable for Model 35/2 and is supplied with special wheel frame chassis, the wheel of which is interchangeable with those on the motorcycle.

£25 - 5 - 0

35/2 BIG TWIN CONTROL LAY-OUT

ENGLISH EXPORT

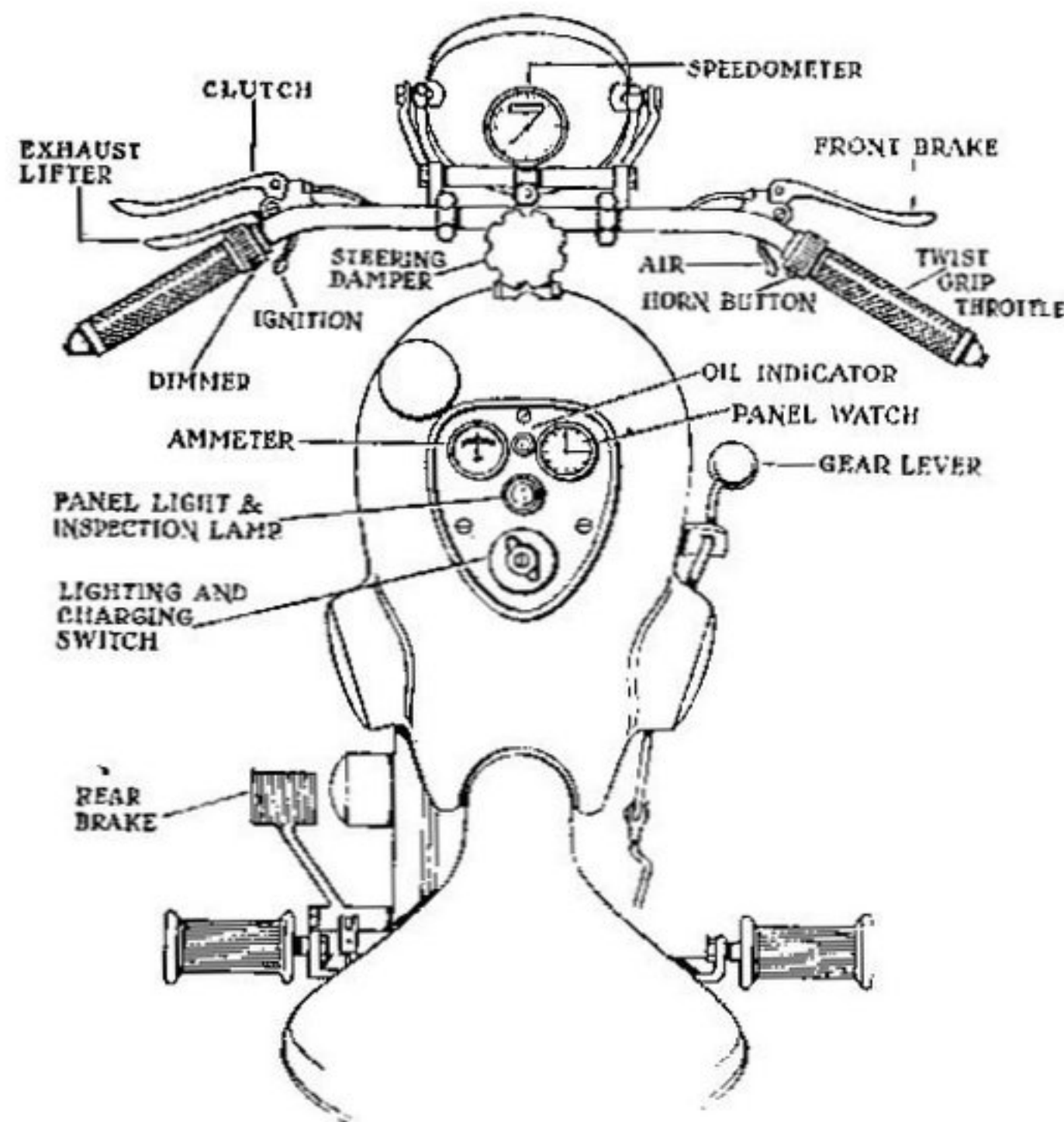

CONTROL LAY-OUT. The illustration on the left shows the English Control Lay-out on the Model 35/2.

The position of the Controls is in accordance with the usual practice in this country, namely: Twist Grip, Front Brake, Air Control Lever and horn button on the right handlebar. Clutch, exhaust valve lifter, ignition lever and dipping and dimming device on the left handlebar. The gear lever is situated on the right-hand side of the Petrol Tank and the rear brake pedal on the left-hand side of the machine. Other Controls such as Steering Damper, Shock absorber, lighting switches, etc., are the same on both the English and Export Models.

Turning to the Export Model illustrated on the right, it will be seen that long touring handlebars are employed with

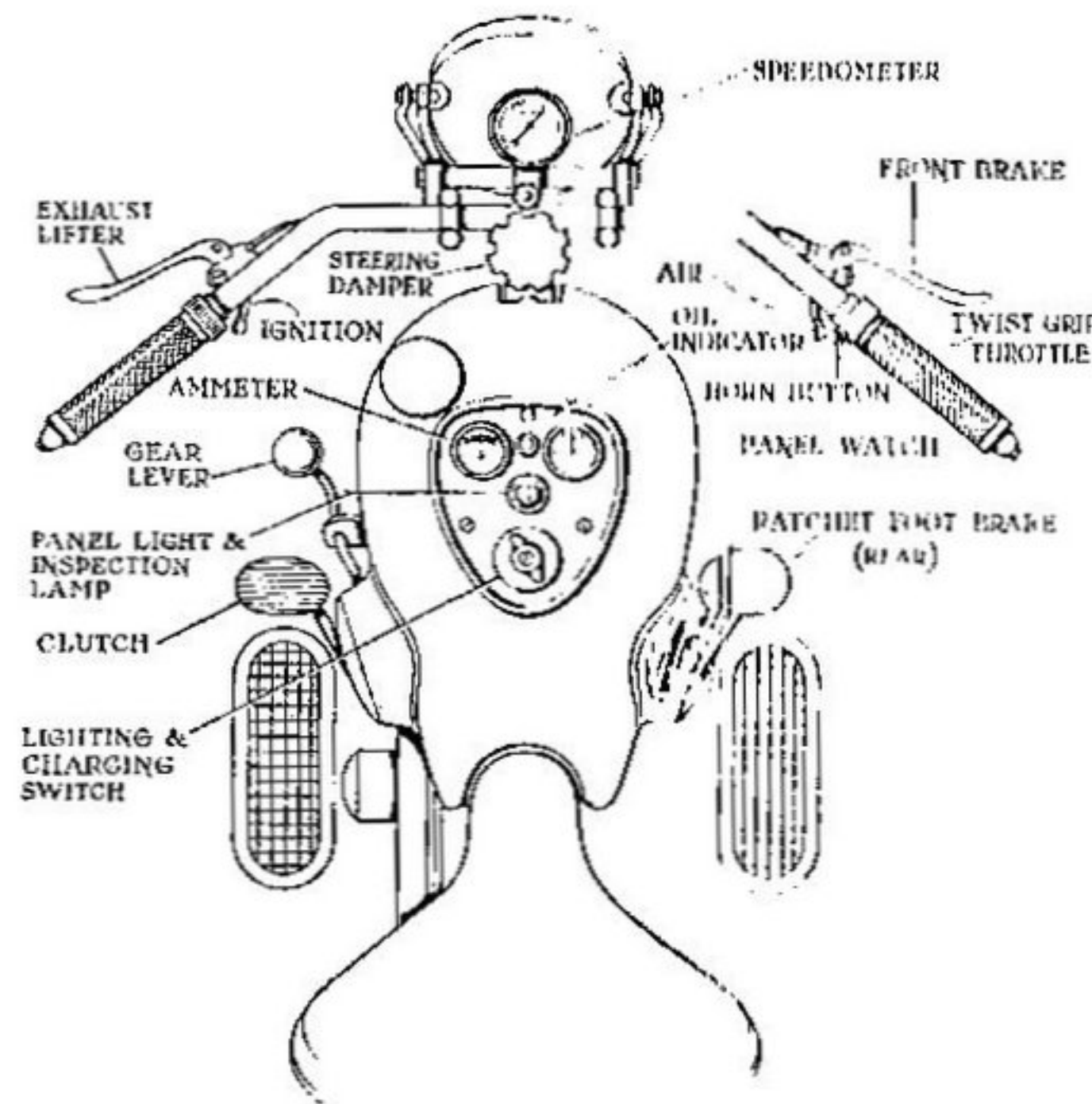

the twist grip, front brake, air control lever and horn button situated on the right handlebar. On the left handlebar will be found the exhaust lifter, ignition control lever and dipping and dimming device. The gear change lever is placed on the left-hand side of the petrol tank. The clutch is foot controlled by a pedal situated in front of the left footboard and the rear brake is controlled by a pedal in front of the right footboard. There is a ratchet locking device on the rear brake pedal.

Intending customers have the option of purchasing either the English or Export Model for use in England or abroad, although the Export Model has been specially designed for overseas conditions and is used in large numbers by Police and other official bodies throughout the world.

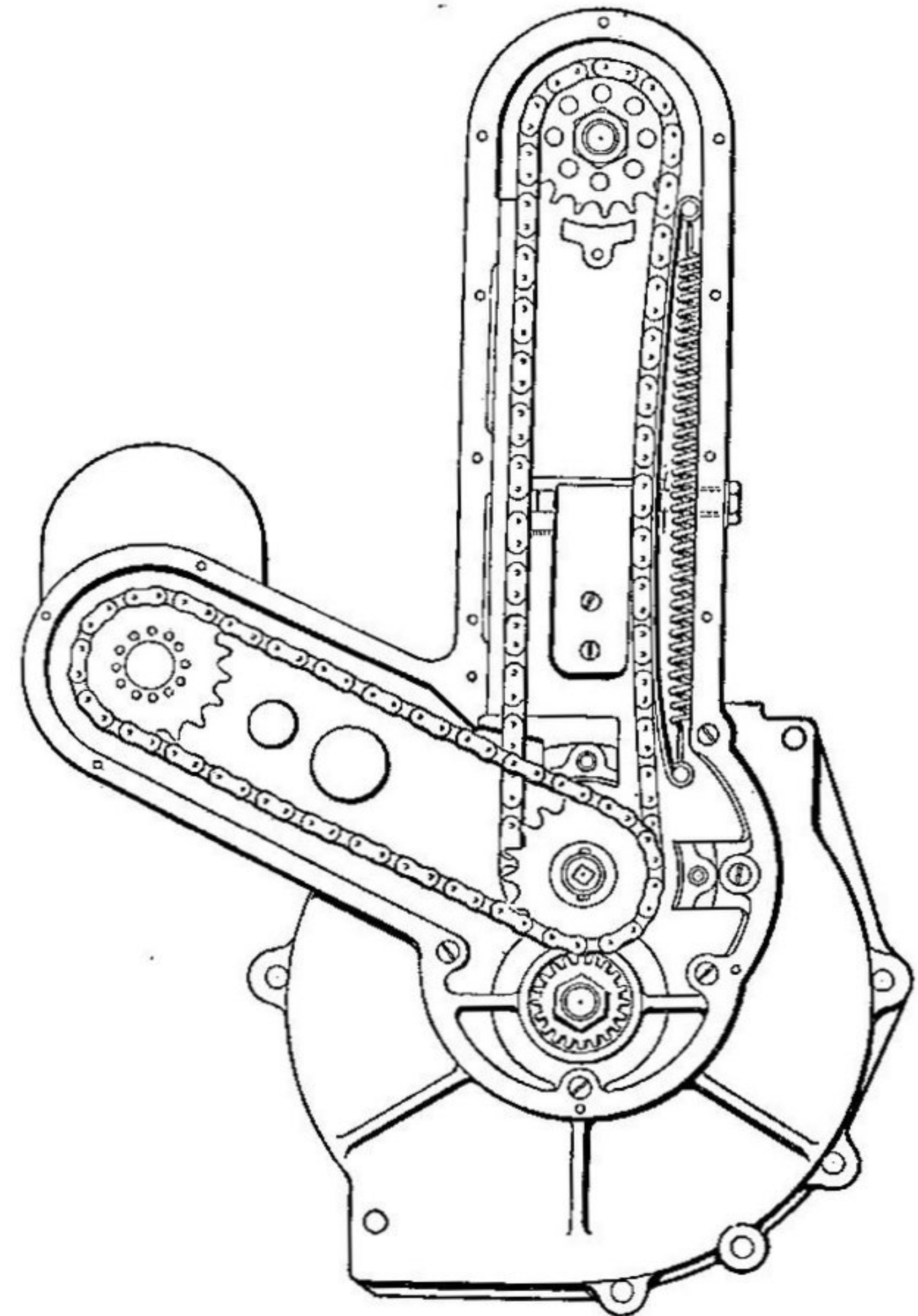

The illustration above shows the well-known "A.J.S." Camshaft Chain drive in which is incorporated a tensioning device and re-action damper. This method of driving the camshaft was employed in our actual T.T. Models, and it will be remembered that "A.J.S." was the only make to obtain 100 per cent. finishers in the Senior Race, each entrant gaining a Replica.

EQUIPMENT

	£	s.	d.		£	s.	d.
Lucas Magdyno Electric Lighting, together with flush fitting Instrument Panel containing Ammeter, Main Switches and removable Inspection Light, with provision for fitting an 8-day Clock on 35/7 and 35/10 Competition Models...	5	17	6	27 in. x 4 in. Tyres on Models 35/6, 35/8, 35/18, 35/9, 35/7 and 35/10	1	0	0
Lucas Magdyno Electric Lighting set with Switch at back of Head Lamp. Suitable for 35/7 and 35/10 Racing Models	5	10	0	Lucas Electric Horn on 35/7 and 35/10	15	0	0
Smith's Gear-box-driven Speedometer, mounted over Front Forks :				Chromium-plated Tank on Model 35/18	1	0	0
Trip	2	5	0	Detachable Luggage Carrier on Models 35/12, 35/5, 35/16, 35/4 and 35/18	12	6	0
Non-Trip	2	0	0	Polished out Cylinder Head, Ports, etc., on O.H.V. Models	1	0	0
Smith's 100 m.p.h. Speedometer and Revolution Counter Combination set on Models 35/7 and 35/10	5	0	0	Smith's 8-day Clock in Instrument Panel	1	10	0
Four-speed Gear Box in lieu of three-speed on Models 35/5 and 35/9	1	0	0	Legshields	1	5	0
26 in. x 3.50 in. Tyres on Models 35/6, 35/7, 35/18, 35/8, 35/9 and 35/10	12	0	0				

All prices and specifications are subject to alteration without notice.

GUARANTEE

We do not appoint agents for the sale on our behalf of our Motor Cycles and other goods, but we assign to Motor Cycle Dealers areas in which we supply to such Dealers exclusively for the re-sale in such areas. No such dealer is authorised to transact any business, give any warranty, make any representation, or incur any liability on our behalf.

We give the following guarantee with our motorcycles, motorcycle combinations and sidecars, which is given in place of any implied conditions, warranties or liabilities whatsoever, statutory or otherwise, all such implied conditions, warranties and liabilities being in all cases excluded. Any statement, description, condition or representation contained in any catalogue, advertisement, leaflet or other publication shall not be construed as enlarging, varying or overriding this guarantee. In the case of machines (a) which have been used for "hiring out" purposes or (b) any motorcycle and/or sidecar used for any dirt track, cinder track or grass track racing or competitions (or any competition of any kind within an enclosure for which a charge is made for admission to take part in or view the competition) or (c) machines from which the trade mark, name or manufacturing number has been removed, no guarantee, condition or warranty of any kind is given or is to be implied.

We guarantee, subject to the conditions mentioned below, that all precautions which are usual and reasonable have been taken by us to secure excellence of materials and workmanship, but this guarantee is to extend and be in force for six months only from date of purchase, and damages for which we make ourselves responsible under this guarantee are limited to the free supply of a new part in exchange for the part of the motorcycle, motorcycle combination or sidecar which may have proved defective. We do not undertake to replace or refix, or bear the cost of replacing or refixing, such new part in the motorcycle, motorcycle combination or sidecar. We undertake, subject to the conditions mentioned below, to make good at any time within six months any defects in these respects. As motorcycles, motorcycle combinations and sidecars are easily liable to derangement by neglect or misuse this guarantee does not apply to defects caused by wear and tear, misuse or neglect.

The term "misuse" shall include amongst others the following acts:—

1. The attaching of a sidecar to a motorcycle in such a manner as to cause damage or calculated to render the latter unsafe when ridden.
2. The use of a motorcycle or of a motorcycle and sidecar combined, when carrying more persons or a greater weight than that for which the machine was designed by the manufacturers.

3. The attaching of a sidecar to a motorcycle by any form of attachment not provided, supplied, or approved by us or to a motorcycle which is not designed for such use.

Any motorcycle, motorcycle combination or sidecar sent to us to be plated, enamelled or repaired will be repaired upon the following conditions, i.e., we guarantee that all precautions which are usual and reasonable have been taken by us to secure excellence of materials and workmanship, such guarantee to extend and be in force for three months only from the time such work shall have been executed or until the expiration of the six months above referred to, and this guarantee is in lieu and in exclusion of any common law or statute warranty or condition, and the damages recoverable are limited to the cost of any further work which may be necessary to amend and make good the work found to be defective.

CONDITIONS OF GUARANTEE

If a defective part should be found in our motorcycles, motorcycle combinations or sidecars, or in any part supplied by way of exchange before referred to, it must be sent to us CARRIAGE PAID, and accompanied by an intimation from the owner that he desires to have it repaired or exchanged free of charge under our guarantee, and he must also furnish us at the same time with the number of the machine, the date of the purchase or the date when the alleged defective part was exchanged as the case may be.

Failing compliance with the above, such articles will lie here AT THE RISK OF THE OWNER, and this guarantee and any implied guarantee, warranty or condition shall not be enforceable.

We do not guarantee specialities such as tyres, saddles, chains, electrical equipment, lamps, etc., or any component parts supplied to the order of the Purchaser differing from standard specifications supplied with our motorcycles, motorcycle combinations, sidecars or otherwise.

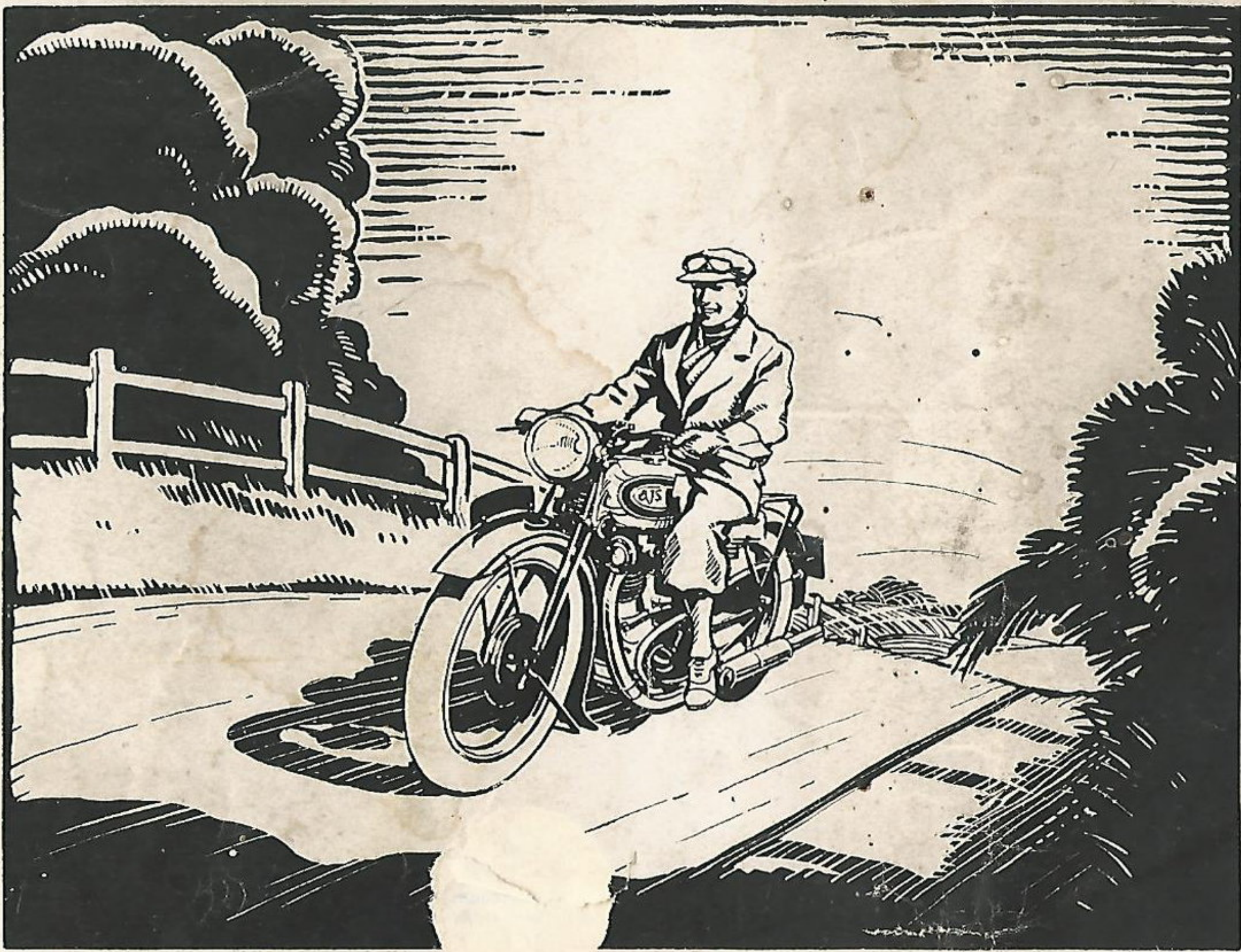

A
J
S

MOTORCYCLES
1935