

AMAL

August, 1958

LIST No. 529 (Issue No. 3)



SPARE PARTS FOR RACING CARBURETTOR

(with Type 302 Float Chamber).

List of MIXING CHAMBER PARTS

COMPONENT	FOR T15GP	FOR T10GP	List Price	FOR T5GP	List Price	FOR T3GP	List Price
Mixing Chamber Body	Specify Engine Details			Specify Engine Details		Specify Engine Details	
Mixing Chamber Top	316/097	316/045		316/049		316/414	
Mixing Chamber Cap	316/103	316/046		316/050		316/412	
Lock Spring for Mixing Chamber Cap ..	316/098	316/126		316/048		316/402	
Adjuster for Throttle Cable	316/159	316/159		316/159		316/159	
Lock Nut for ditto	3369	3369		3369		3369	
Throttle Cable Adjuster Sheath	316/083	316/083		316/083		316/083	
Throttle Valve (Standard)	316/104	316/010		316/020		316/413	
Throttle Valve, opposite Standard, Twin Carbs.	316/185	316/013		316/189		—	
Throttle Valve Screwed Nipple	5/204	5/204		5/204		5/204	
†Throttle Valve Spring	175/308	316/044		175/309		316/466	
Jet Needle (Standard)	316/007	316/007		316/146		—	
Jet Needle (Weak)	316/030	316/030		316/029		316/408	
Jet Needle Clip	316/021	316/021		316/021		316/021	
Jet Needle Clip Screw	316/015	316/045		316/015		316/015	
*Choke Adaptor (Please state bore size) ..	—	—		—		—	
Choke Adaptor Washer	316/100	316/005		316/025		316/462	
Choke Adaptor Securing Screws	316/006	316/006		316/006		316/006	
Spray Tube	316/067	316/067		316/144		316/144	
*Air Tube (Please state bore size when ordering)	—	—		—		—	
Air Tube Lock Ring	175/115	175/119		175/371		316/411	
Main Jet	3326	3326		3326		3326	
Jet Holder	15/625	15/625		15/625		316/027	
Jet Holder Plug Screw	3348	3348		3348		316/028	
Jet Holder Plug Screw (Norton)	—	185/282		—		—	
Needle Jet	316/065	316/065		316/065		316/065	
Air Valve Cable Adjuster	2626	2626		2626		2626	
Lock Nut for ditto	2627	2627		2627		2627	
Air Barrel Top	2507	2507		2507		2507	
Air Valve	2502	2502		2502		2502	
Air Valve Spring	2558	2558		2558		2558	
Air Valve Nipple Holder	2503	2503		2503		2503	
Air Valve Nipple	2629	2629		2629		2629	
Air Jet	316/052	316/052		316/052		316/052	
†Air Jet Plug Screw	316/066	316/066		316/066		316/456	
Air Jet Plug Screw Washer	13/163	13/163		13/163		38/023	
Pilot Adjuster and Needle	316/283	316/283		316/283		316/283	
Pilot Needle Spring	2980	2980		2980		2980	
Pilot Needle Click Spring	2982	2982		2982		2982	
Pilot Needle Insert	2966	2966		2966		2966	
Pilot Needle Plug Screw	2403	2403		2403		2403	
Banjo Connection for Remote Float Chamber ..	14/218	14/218		14/218		—	
Banjo Washer	36/006	36/006		36/006		36/006	

*These parts are not normally supplied separately as they are machined in position with the mixing chamber body.

†For Carburettors marked GP1 this component is No. 316/456.

‡For Carburettors marked GP1 this component is No. 316/458 for 10GP1 Carburettors and 316/459 for 5GP Carburettors.

**AMAL LTD., HOLDFORD ROAD, WITTON,
BIRMINGHAM 6, ENGLAND**

'Phone : Birmingham, BIRchfields 4571.
(P.B.X. 6 lines)

Telegrams : "AMALCARB, 'PHONE,
BIRMINGHAM."

G.P. Mixing Chamber

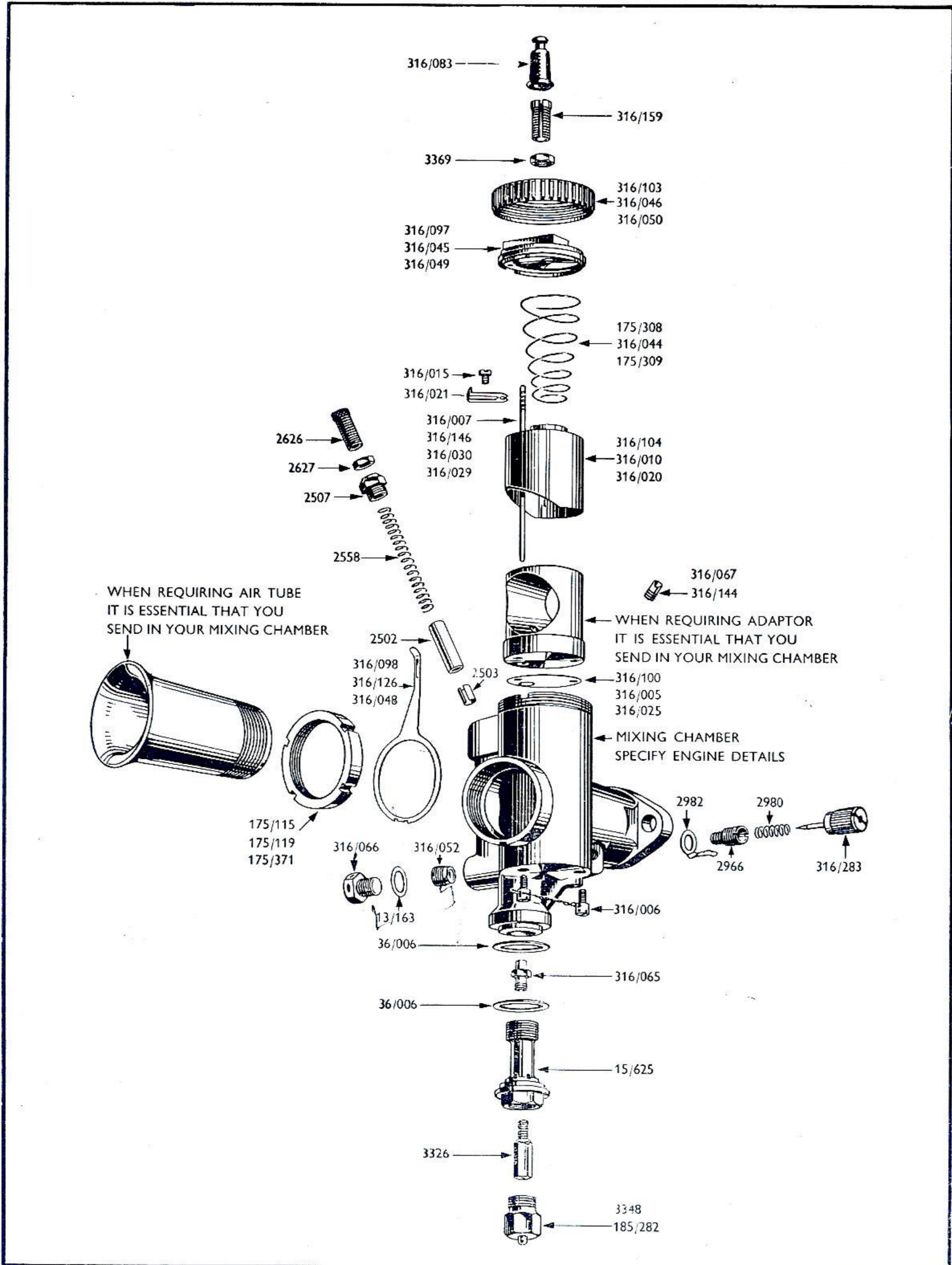

PART NUMBERS FOR T3GP ARE OMITTED ON THE ABOVE ILLUSTRATION.

Type 302 T.T. Float Chamber

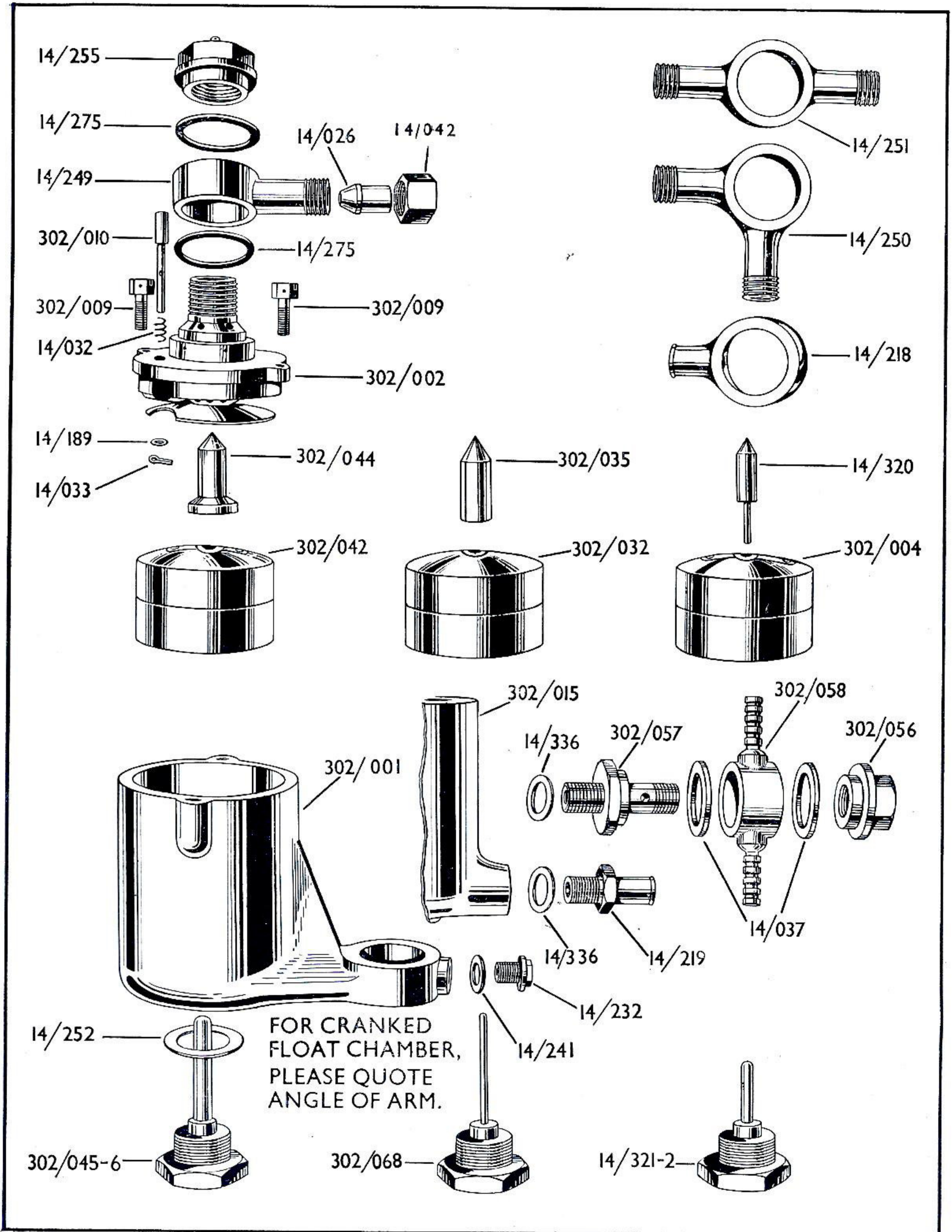



SPARE PARTS LIST

for TYPE 302 LARGE TOP FEED FLOAT CHAMBER

COMPONENT	TYPE 302/1	(Remote) TYPE 302/3	TYPE 302/10	(Remote) TYPE 302/11	(Remote) TYPE 302/17
	PART No.	PART No.	PART No.	PART No.	PART No.
Complete Float Chamber	302/1	302/3	302/10	302/11	302/17
Float Chamber Body only	302/001	302/015	302/001	302/015	302/015
Cover complete with Baffle	302/002	302/002	302/002	302/002	302/002
Cover Fixing Screws	302/009	302/009	302/009	302/009	302/009
Tickler	302/010	302/010	302/010	302/010	302/010
Tickler Spring	14/032	14/032	14/032	14/032	14/032
Tickler Cotter	14/033	14/033	14/033	14/033	14/033
Tickler Washer	14/189	14/189	14/189	14/189	14/189
Float	302/004	302/004	—	—	—
Float	302/032	302/032	—	—	—
Float See note	302/042	302/042	302/042	302/042	302/042
Float Needle	14/320	14/320	—	—	—
Float Needle below re	302/035	302/035	—	—	—
Float Needle	302/044	302/044	302/044	302/044	302/044
Base Plug and Guide modification *	14/321-2	14/321-2	—	—	—
Base Plug and Guide	14/322-302/036	14/322-302/036	—	—	—
Base Plug and Guide	302/045-6	302/045-6	302/045-6	302/045-6	302/045/6
Base Plug Washer	14/252	14/252	14/252	14/252	14/252
Banjo Single	14/249	14/249	14/249	14/249	14/249
Banjo Twin 90°	14/250	14/250	14/250	14/250	14/250
Banjo Twin 180°	14/251	14/251	14/251	14/251	14/251
Banjo Nut	14/255	14/255	14/255	14/255	302/043
Banjo Washers	14/275	14/275	14/275	14/275	14/275
Petrol Union Nuts	14/042	14/042	14/042	14/042	14/042
Petrol Union Nipples	14/026	14/026	14/026	14/026	14/026
Plug Screw	14/232	—	14/232	—	—
Plug Screw Washer	14/241	—	14/241	—	—
Float Chamber Connection	—	14/219	—	14/219	302/070
Float Chamber Connection Washer ..	—	14/336	—	14/336	14/336
Mixing Chamber Connection	—	14/218	—	14/218	—
Banjo Connection (for M/ch.)	—	302/057	—	302/057	—
Banjo Connection Washer	—	14/336	—	14/336	—
Banjo	—	302/058	—	302/058	—
Banjo Washers	—	14/037	—	14/037	—
Banjo Nut	—	302/056	—	302/056	—
Base Plug and Guide (Excelsior) ..	302/069-046	—	302/069-046	—	—

*Original part numbers 302/004, 14/320, 14/321-2, were modified to 302/032, 302/035, 14/322-302/036 since when a further modification was made, *i.e.*, 302/042, 302/044, 302/045-6.

We suggest that parts prior to the last modification should be replaced as an assembly so bringing the float chamber to the latest setting.

GUARANTEE.—The Company take all possible reasonable care in the manufacture and the quality of their products. Purchasers are informed that, any part proved to be defective in manufacture or quality, and returned to the works within six months of its purchase new, will be replaced. The Company must respectfully point out however, that its responsibility and that of its agents, stockists and dealers, is limited to this Guarantee, and that they cannot, under any circumstances, be held responsible for any loss or for any contingent or resulting liability arising through any defect. These conditions of sale and use also apply when the Company's products form part of the original equipment of machines purchased new.

**AMAL LTD., HOLDFORD ROAD, WITTON,
BIRMINGHAM 6, ENGLAND**

'Phone : Birmingham, BIRchfields 4571.
(P.B.X. 6 lines)

Telegrams : "AMALCARB, 'PHONE,
BIRMINGHAM."