

# AMAL

LIST No. A449.

## SPARE PARTS LIST for 'TT9' CARBURETTER (with Type 302 Float Chamber).

### Price List of MIXING CHAMBER PARTS.

COMPONENT	FOR TYPE 15T.T.9	PRICE s. d.	FOR TYPE 10T.T.9	PRICE s. d.		
Mixing Chamber Body (Light Metal) .. .. .	} Specify Engine details	60 0	} Specify Engine details	65 0		
Mixing Chamber Top .. .. .					175/312	5 0
Mixing Chamber Cap .. .. .	175/316	5 0	175/317	5 0		
Air Cable Adjuster .. .. .	2626	6	2626	6		
Air Cable Adjuster Locknut .. .. .	2627	2	2627	2		
Throttle Cable Adjuster .. .. .	175/314	6	175/314	6		
Throttle Cable Adjuster Locknut .. .. .	175/315	2	175/315	2		
Air Barrel Top .. .. .	2507	1 0	2507	1 0		
Choke Adaptor, 1" Bore .. .. .	175/109	25 0	—	—		
Choke Adaptor, 1 1/16" Bore .. .. .	} Machined in position with Mixing Chamber Body which should be sent to Amal, Ltd.	25 0	—	—		
Choke Adaptor, 1 1/8" Bore .. .. .			175/102	25 0	—	
Choke Adaptor, 1 3/16" Bore .. .. .			—	—	175/101	25 0
Main Jet .. .. .	3326	1 6	3326	1 6		
Jet Choke Tube .. .. .	3438	2 6	3438	2 6		
Needle Jet .. .. .	3970	2 6	3970	2 6		
Jet Needle .. .. .	3971	3 0	3971	3 0		
Jet Needle Clip .. .. .	4/230	6	4/230	6		
Throttle Valve (Please state number of cut-away) .. .. .	175/310	8 6	175/311	8 6		
Throttle Valve Spring .. .. .	175/308	1 0	175/309	1 0		
Air Valve .. .. .	2502	1 6	2502	1 6		
Air Valve Spring .. .. .	2558	4	2558	4		
Jet Holder .. .. .	15/625	5 0	15/625	5 0		
Jet Holder Plug Screw .. .. .	3348	1 6	3348	1 6		
Adaptor Washer .. .. .	134/107	2	134/107	2		
Float Chamber Arm Washer .. .. .	36/006	2	36/006	2		
Pilot Needle .. .. .	2981/2967	2 0	2981/2967	2 0		
Pilot Needle Insert .. .. .	2966	1 6	2966	1 6		
Pilot Needle Spring .. .. .	2980	3	2980	3		
Pilot Needle Spring Catch .. .. .	2982	2	2982	2		
Nipple Holder for Air Valve .. .. .	2503	2	2503	2		
Carburetter Cable Nipple .. .. .	2629	2	2629	2		
Small Plug Screw .. .. .	2403	3	2403	3		
Adaptor Location Peg .. .. .	134/105	4	134/105	4		
Outlet Clip for 1 1/8" Outlet .. .. .	} State Material of Mixing Chamber Body, i.e., Brass or Light Metal .. .. .	2 6	—	—		
Outlet Clip for 1 1/4" Outlet .. .. .			27/073	2 6	—	
Outlet Clip for 1 3/8" Outlet .. .. .			—	—	27/072	3 0
Outlet Clip for 1 1/2" Outlet .. .. .			—	—	27/072	4 0
Outlet Clip Screw .. .. .	1962	9	1962	9		
Air Intake Tube, 1" Bore .. .. .	} Machined in position with Mixing Chamber Body which should be sent to Amal, Ltd.	10 0	—	—		
Air Intake Tube, 1 1/16" Bore .. .. .			175/114	10 0	—	
Air Intake Tube, 1 1/8" Bore .. .. .			175/113	10 0	—	
Air Intake Tube, 1 5/32" Bore .. .. .			—	—	175/118	10 0
Air Intake Tube, 1 3/16" Bore .. .. .			—	—	185/121	10 0
Lock Ring for Air Intake Tube .. .. .	175/115	4 0	175/117	10 0		
Mixing Chamber Cap Lock Spring .. .. .	175/306	1 6	175/119	4 0		
			175/307	1 6		

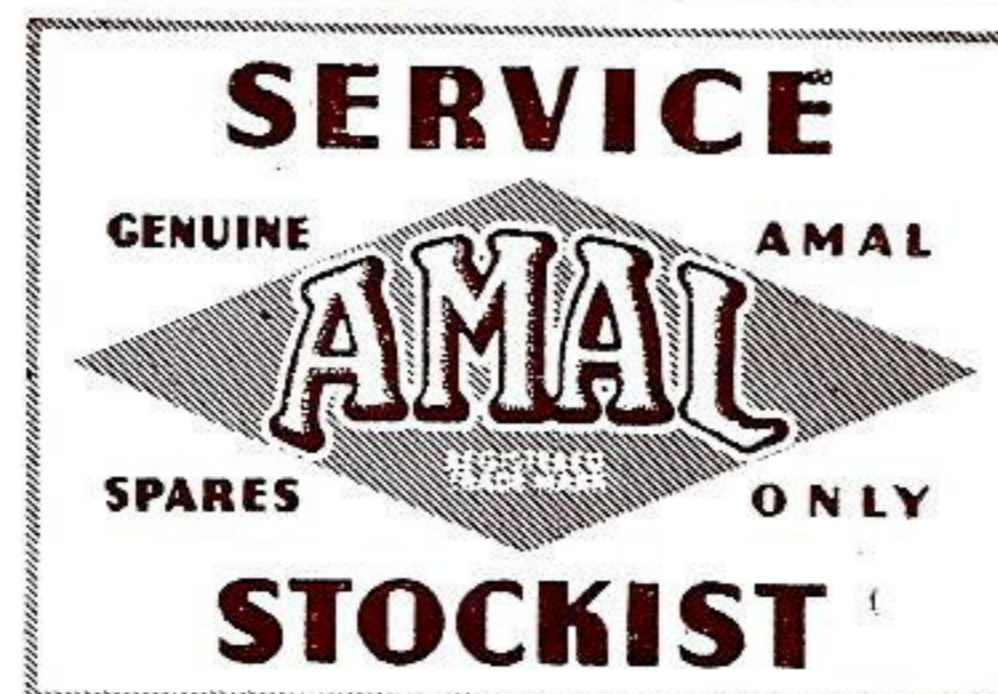

# T.T.9 Mixing Chamber

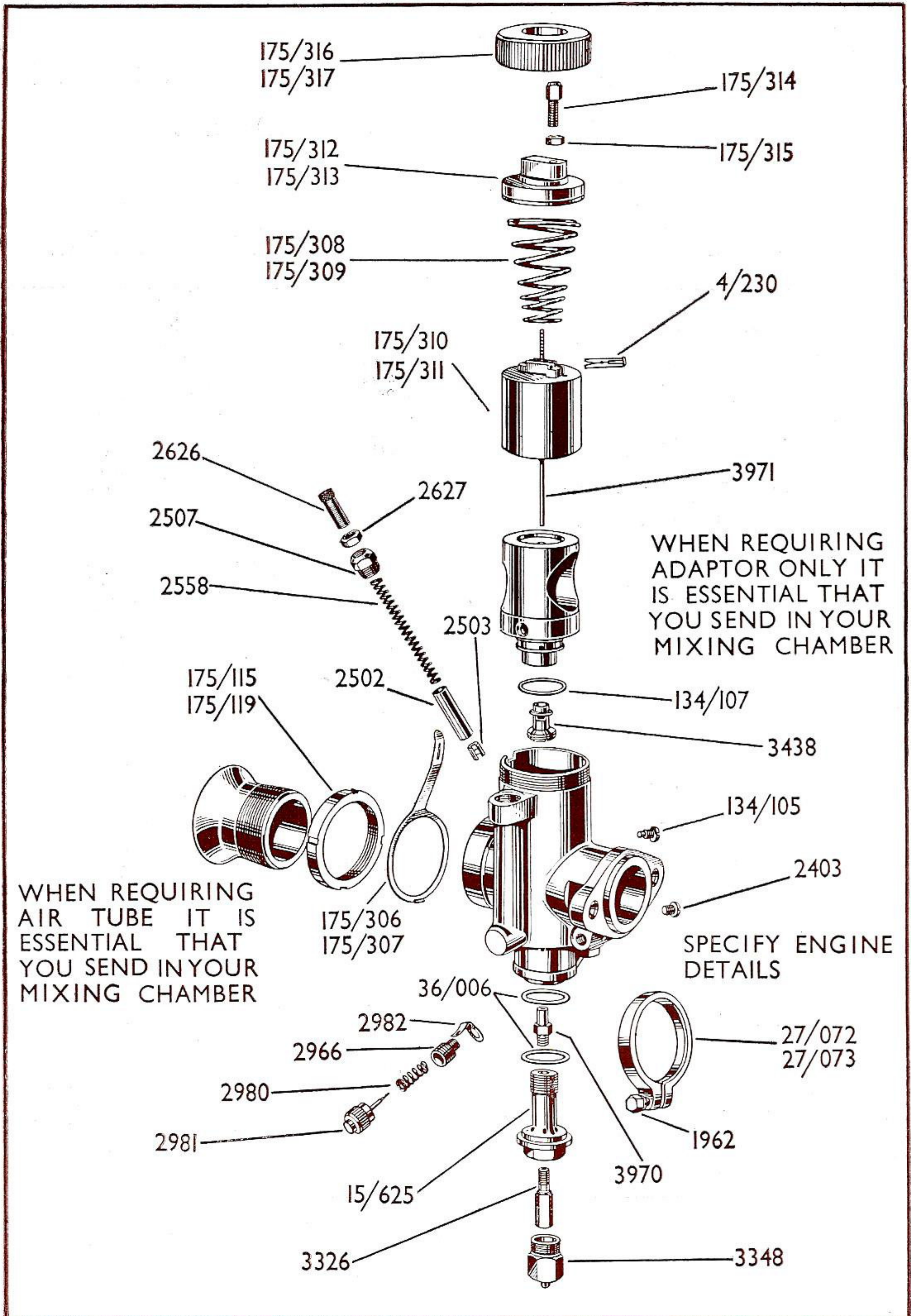

PRICES ETC., REFER TO PAGE ONE.

# Type 302 T.T. Float Chamber

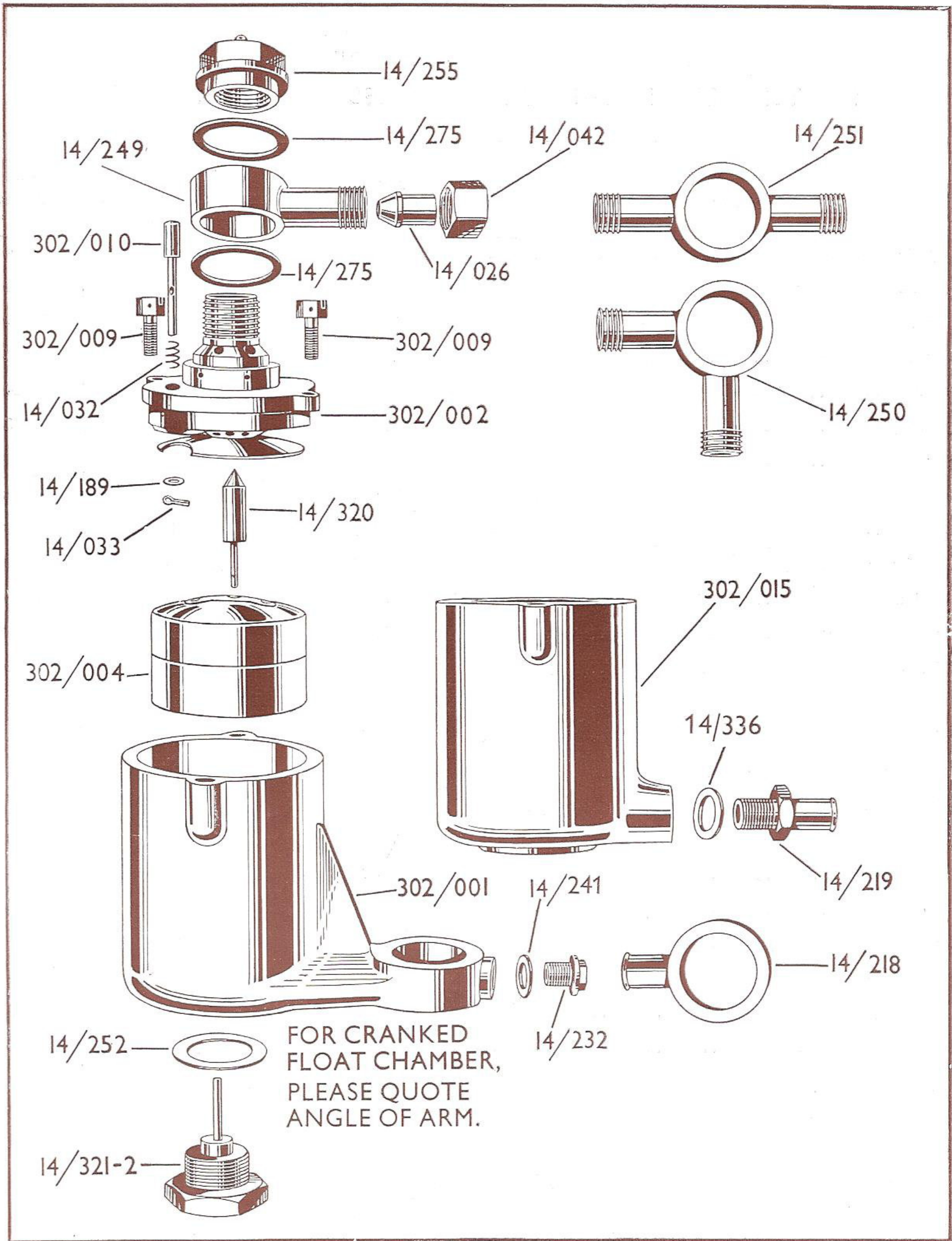

PRICES ETC., REFER TO PAGE FOUR.

# SPARE PARTS LIST

for TYPE 302 LARGE T.T. TOP FEED FLOAT CHAMBER

COMPONENT	TYPE 302/1	(Remote) TYPE 302/3	LIST PRICE S. D.
	PART No.	PART No.	
Complete Float Chamber .. .. .	302/1*	302/3	70 0
Float Chamber Body only .. .. .	302/001*	302/15	30 0
Cover complete with Baffle .. .. .	302/002	302/002	20 0
Cover Fixing Screws .. .. .	302/009	302/009	4
Tickler .. .. .	302/010	302/010	10
Tickler Spring .. .. .	14/032	14/032	2
Tickler Cotter .. .. .	14/033	14/033	1
Tickler Washer .. .. .	14/189	14/189	1
Float .. .. .	302/004	302/004	5 0
Float Needle .. .. .	14/320	14/320	2 0
Base Plug and Guide .. .. .	14/322	14/322	3 0
Base Plug Washer .. .. .	14/252	14/252	2
Banjo, Single .. .. .	14/249	14/249	3 9
Banjo, Twin, 90° .. .. .	14/250	14/250	7 6
Banjo, Twin, 180° .. .. .	14/251	14/251	7 6
Banjo Nut .. .. .	14/255	14/255	1 6
Banjo Washers .. .. .	14/275	14/275	2
Petrol Union Nuts .. .. .	14/042	14/042	9
Petrol Union Nipples .. .. .	14/026	14/026	5
Plug Screw .. .. .	14/232	—	6
Plug Screw Washer .. .. .	14/241	—	1
Float Chamber Connection .. .. .	—	14/219	3 9
Float Chamber Connection Washer .. .. .	—	14/336	2
Mixing Chamber Connection .. .. .	—	14/218	2 6

\*When ordering state angle if any required.

*All Prices are subject to alteration without notice.*

**AMAL LTD., BIRMINGHAM, England.**

Telephone: BIRchfields 4571 (5 lines).

Telegrams: Amalcarb, Birmingham.