

AMAL

August, 1957

LIST No. 441

Issue No. 3

SPARE PARTS LIST for T.T. CARBURETTORS

MIXING CHAMBER PARTS (Illustrations)

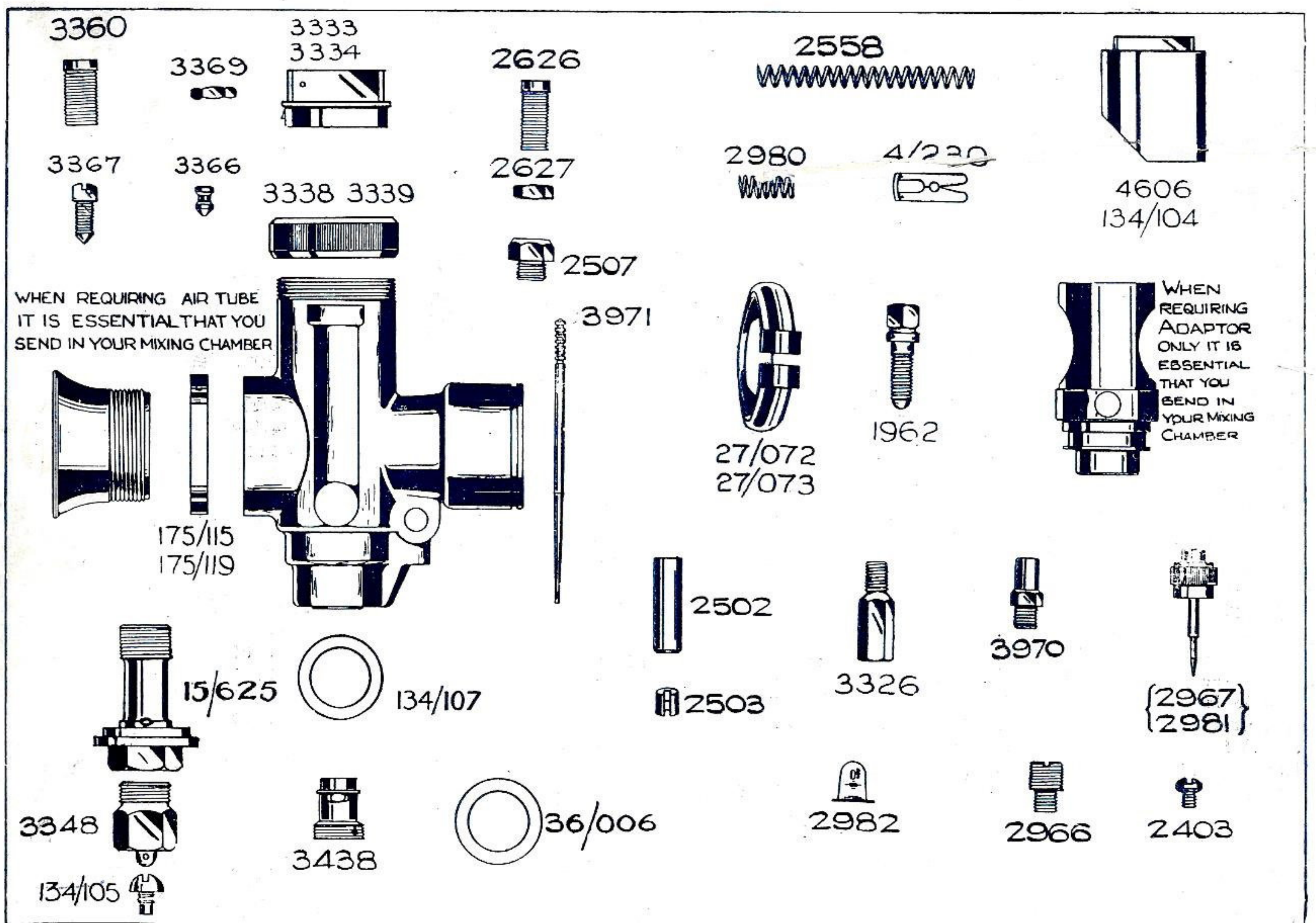

**AMAL LTD., HOLDFORD ROAD, WITTON,
BIRMINGHAM 6, ENGLAND**

Phone: Birmingham, BIRchfields 4571.
(P.B.X. 6 lines)

Telegrams: "AMALCARB, 'PHONE,
BIRMINGHAM."



List of MIXING CHAMBER PARTS

Component	For Type 15T.T.	For Type 10T.T.
Mixing Chamber Body (Light Metal)	} Specify Engine details	} Specify Engine details
Mixing Chamber Top	3333	3334
Mixing Chamber Cap	3339	3338
Air Cable Adjuster	2626	2626
Air Cable Adjuster Locknut	2627	2627
Throttle Cable Adjuster	3360	3360
Throttle Cable Adjuster Locknut	3369	3369
Lock Plunger for Mixing Chamber Top	3366	3366
Adjusting Screw for Lock Plunger	3367	3367
Air Bar	2507	2507
Choke Adaptor, 1" Bore	175/109	—
Choke Adaptor, 1 1/16" Bore	175/102	—
Choke Adaptor, 1 1/8" Bore	—	175/108
Choke Adaptor, 1 5/32" Bore	—	175/272
Choke Adaptor, 1 3/16" Bore	—	175/101
Main Jet	3326	3326
Jet Choke Tube	3438	3438
Needle Jet	3970	3970
Jet Needle	3971	3971
Jet Needle Clip	4/230	4/230
Throttle Valve (Please state number of cut-away)	4606	134/104
Throttle Valve Spring	2558	2558
Air Valve	2502	2502
Air Valve Spring	2558	2558
Jet Holder	15/625	15/625
Jet Holder Plug Screw	3348	3348
Adaptor Washer	134/107	134/107
Float Chamber Arm Washer	36/006	36/006
Pilot Needle	2981/2967	2981/2967
Pilot Needle Insert	2966	2966
Pilot Needle Spring	2980	2980
Pilot Needle Spring Catch	2982	2982
Nipple Holder for Air Valve	2503	2503
Carburettor Cable Nipple	2629	2629
Small Plug Screw	2403	2403
Adaptor Location Peg	134/105	134/105
Outlet Clip for 1 1/8" Outlet	} State Material of	—
Outlet Clip for 1 1/4" Outlet	} Mixing Chamber Body,	—
Outlet Clip for 1 3/8" Outlet	} i.e., Brass or	27/072
Outlet Clip for 1 1/2" Outlet	} Light Metal	27/072
Outlet Clip Screw	1962	1962
Air Intake Tube, 1" Bore	} Machined in position with	—
Air Intake Tube, 1 1/16" Bore	} Mixing Chamber Body	—
Air Intake Tube, 1 1/8" Bore	} which should be sent	175/118
Air Intake Tube, 1 5/32" Bore	} to	185/121
Air Intake Tube, 1 3/16" Bore	} Amal, Ltd.	175/117
Lock Ring for Air Intake Tube	175/115	175/119

AMAL

FLOAT CHAMBER PARTS (Illustrations)

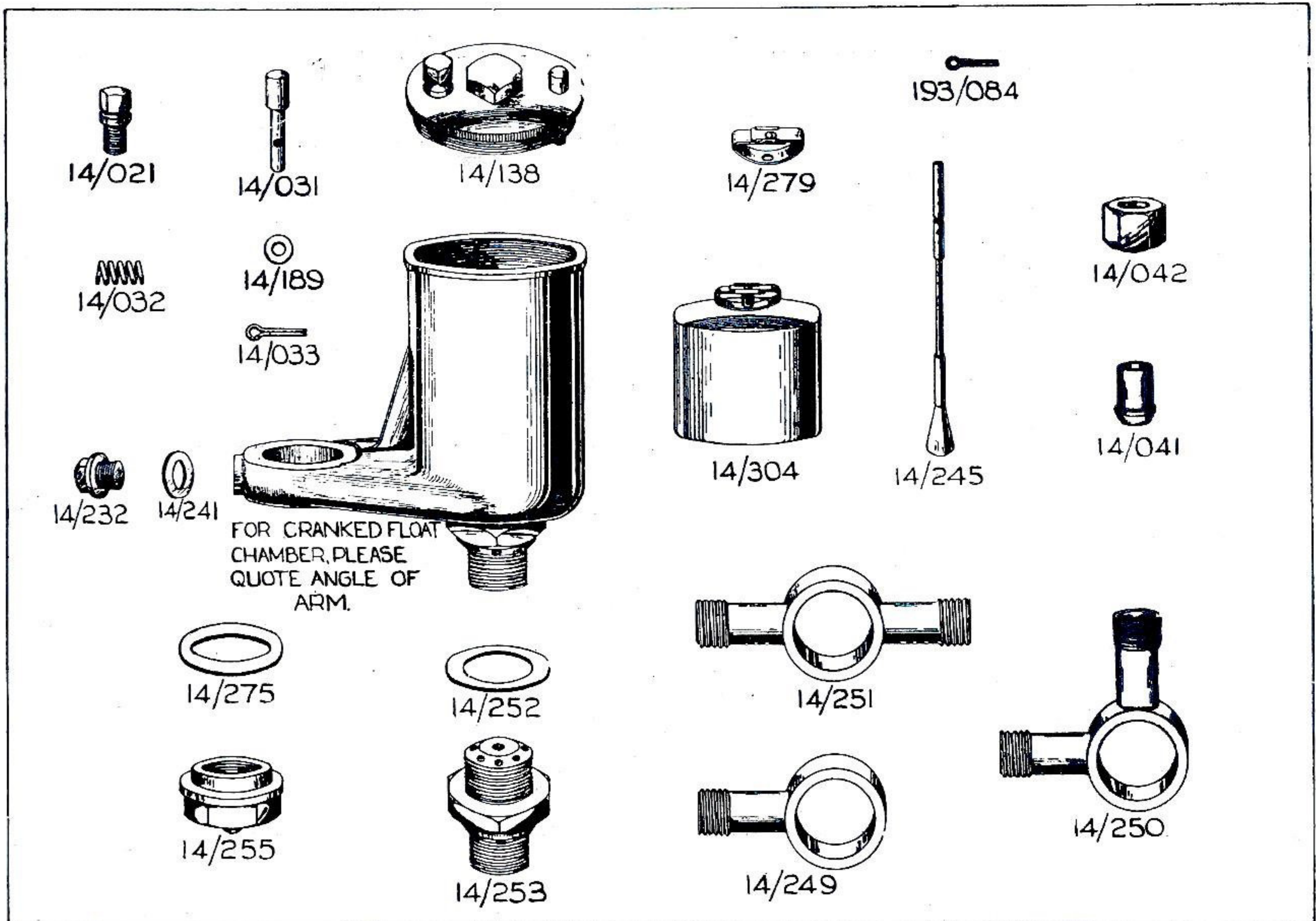

The above illustrations cover Float Chambers
 Type Nos. 14/532, 14/533, 14/534, 14/538 and 15/1812.

MOST PARTS OF FLOAT CHAMBERS TYPE No's. 14/064 and 14/601
 are common to the above.

Refer to page 4 for full details.



LIST No. 441

List of FLOAT CHAMBER PARTS

Component	14/064	14/601	14/532	14/533	14/534	14/538	15/1812	
Float Ch'b'r comp'te	14/064	—	—	—	—	—	—	—
Ditto	—	14/601	—	—	—	—	—	—
Ditto	—	—	14/532	14/533	—	14/538	—	—
Ditto	—	—	—	—	14/534	—	—	—
Ditto	—	—	—	—	—	—	15/1812	—
Fl't Ch'b'r Body only	14/314	—	—	—	—	—	—	15/1812B
Ditto	—	14/316	—	—	—	—	—	15/1812B
Ditto	—	—	14/225R	14/225R	14/225R	14/217R	—	—
For								
Downdraught								
Carbs., please								
specify Angle								
required for								
Float Chamber								
Arm in ad-								
dition to part								
number.								
Cover complete	14/138	14/138	14/138	14/138	14/138	14/138	14/138	14/138
Cover Lock Screw	14/021	14/021	14/021	14/021	14/021	14/021	14/021	14/021
Tickler	14/031	14/031	14/031	14/031	14/031	14/031	14/031	14/031
Tickler Spring	14/032	14/032	14/032	14/032	14/032	14/032	14/032	14/032
Tickler Cotter Pin	14/033	14/033	14/033	14/033	14/033	14/033	14/033	14/033
Tickler Washer	14/189	14/189	14/189	14/189	14/189	14/189	14/189	14/189
Float Needle	14/024S	14/024S	—	—	—	—	—	—
Float Needle	—	—	14/245	14/245	14/245	14/245	14/245	14/245
Float	14/017	14/017	—	—	—	—	—	—
Float	—	—	14/304	14/304	14/304	14/304	14/304	14/304
Float Bow Spring	14/279	14/279	14/279	14/279	14/279	14/279	14/279	14/279
Float Securing Cotter Pin	—	—	193/084	193/084	193/084	193/084	193/084	193/084
Needle Valve Seating	—	—	14/253	14/253	14/253	14/253	14/253	14/253
Needle Valve Seating Washer	—	—	14/252	14/252	14/252	14/252	14/252	14/252
Body Base Plug Screw	—	—	14/232	14/232	14/232	14/232	14/232	14/232
Washer for Body Base Plug Screw	—	—	14/241	14/241	14/241	14/241	14/241	14/241
Banjo (Single)	14/035	14/035	—	—	—	—	—	—
Banjo (Single)	—	—	—	—	14/249	—	—	14/249
Banjo (Twin) 90°	14/043	—	—	—	—	—	—	—
Banjo (Twin) 90°	—	—	—	14/250	—	14/250	—	—
Banjo (Twin) 180°	14/173	—	—	—	—	—	—	—
Banjo (Twin) 180°	—	—	14/251	—	—	—	—	—
Washers for Banjo	14/037	14/037	14/275	14/275	14/275	14/275	14/275	14/275
Banjo Nut	14/036	14/036	—	—	—	—	—	—
Banjo Nut	—	—	14/255	14/255	14/255	14/255	14/255	14/255
Flex. Pipe Connection for Mix. Chbr.	—	—	—	—	—	14/218	—	—
Flex. Pipe Connection for Fl. Chbr.	—	—	—	—	—	14/219	—	—
Washer for Float Chbr. Connection	—	—	—	—	—	120/036	—	—
Petrol Union Nut	14/042	14/042	14/042	14/042	14/042	14/042	14/042	14/042
Petrol Union Nipple	14/041	14/041	14/041	14/041	14/041	14/041	14/041	14/041

GUARANTEE.—The Company take all possible reasonable care in the manufacture and the quality of their products. Purchasers are informed that, any part proved to be defective in manufacture or quality, and returned to the works within six months of its purchase new, will be replaced. The Company must respectfully point out however, that its responsibility and that of its agents, stockists and dealers, is limited to this Guarantee, and that they cannot, under any circumstances, be held responsible for any loss or for any contingent or resulting liability arising through any defect. These conditions of sale and use also apply when the Company's products form part of the original equipment of machines purchased new.

500/8/57. W.

Printed in England.

**AMAL LTD., HOLDFORD ROAD, WITTON,
BIRMINGHAM 6, ENGLAND**

'Phone: Birmingham, BIRchfields 4571.
(P.B.X. 6 lines)

Telegrams: "AMALCARB, 'PHONE,
BIRMINGHAM."