

AMAL

SPARE PARTS LIST for T.T. CARBURETTORS

MIXING CHAMBER PARTS (Illustrations)

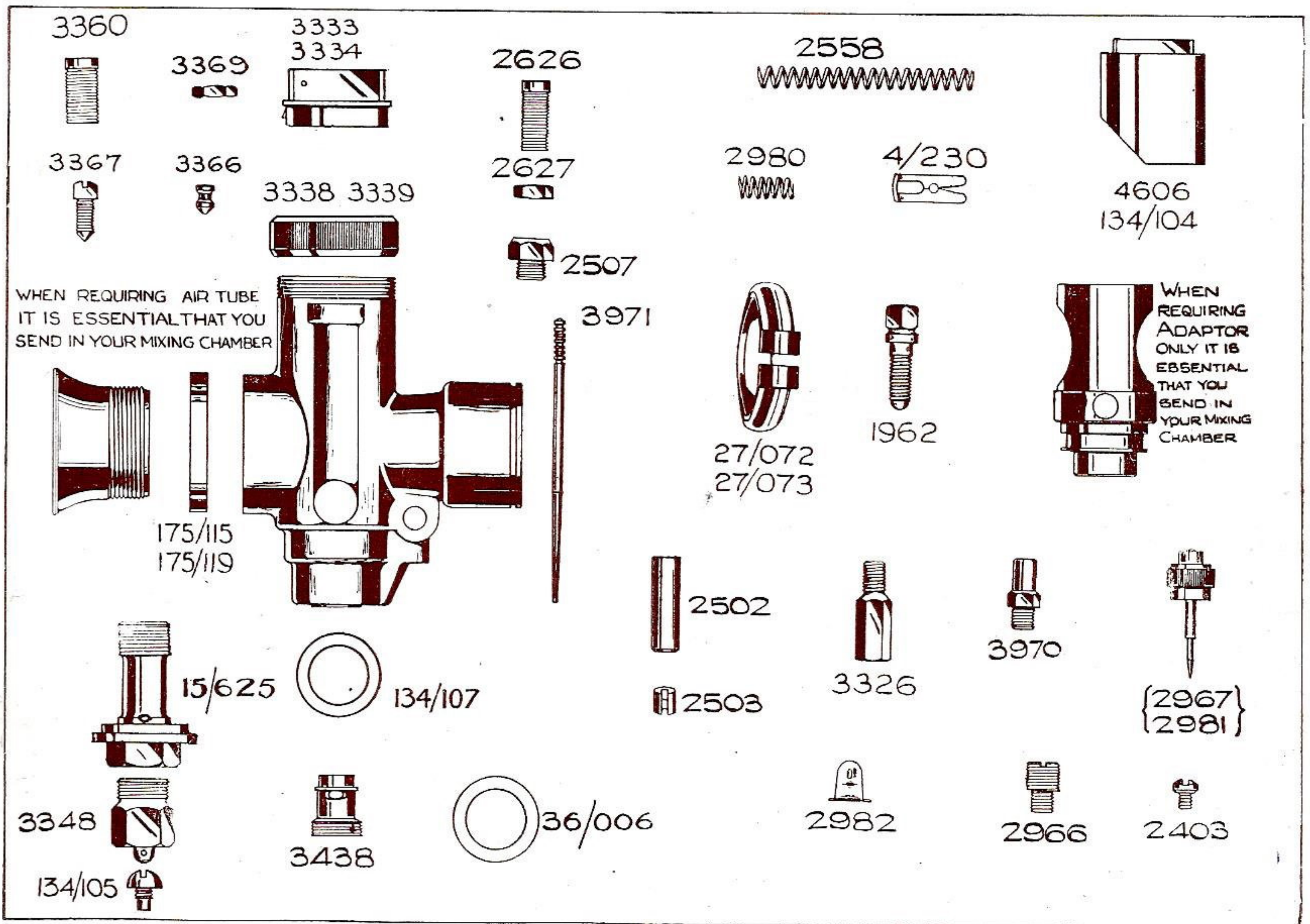

FOR PRICES SEE PAGE 2

AMAL LTD., BIRMINGHAM, England.

Telephone: BIRchfields 4571 (5 lines).

Telegrams: Amalcarb, Birmingham.

AMAL

Price List of MIXING CHAMBER PARTS

Component	For Type 15T.T.	Price s. d.	For Type 10T.T.	Price s. d.		
Mixing Chamber Body (Light Metal)	} Specify Engine details	60 0	} Specify Engine details	65 0		
Mixing Chamber Top		3333		5 0	3334	5 0
Mixing Chamber Cap		3339		5 0	3338	5 0
Air Cable Adjuster		2626		6	2626	6
Air Cable Adjuster Locknut		2627		2	2627	2
Throttle Cable Adjuster		3360		6	3360	6
Throttle Cable Adjuster Locknut		3369		2	3369	2
Lock Plunger for Mixing Chamber Top		3366		6	3366	6
Adjusting Screw for Lock Plunger		3367		2	3367	2
Air Barrel Top		2507		1 0	2507	1 0
Choke Adaptor, 1" Bore	} Machined in position with Mixing Chamber Body which should be sent to Amal, Ltd.	175/109	25 0	—		
Choke Adaptor, 1 1/16" Bore		175/102	25 0	—		
Choke Adaptor, 1 1/8" Bore		—	—	—		
Choke Adaptor, 1 3/16" Bore		—	—	175/101	25 0	
Main Jet	3326	1 6	3326	1 6		
Jet Choke Tube	3438	2 6	3438	2 6		
Needle Jet	3970	2 6	3970	2 6		
Jet Needle	3971	3 0	3971	3 0		
Jet Needle Clip	4/230	6	4/230	6		
Throttle Valve (Please state number of cut-away)	4606	8 6	134/104	8 6		
Throttle Valve Spring	2558	4	2558	4		
Air Valve	2502	1 6	2502	1 6		
Air Valve Spring	2558	4	2558	4		
Jet Holder	15/625	5 0	15/625	5 0		
Jet Holder Plug Screw	3348	1 6	3348	1 6		
Adaptor Washer	134/107	2	134/107	2		
Float Chamber Arm Washer	36/006	2	36/006	2		
Pilot Needle	2981/2967	2 0	2981/2967	2 0		
Pilot Needle Insert	2966	1 6	2966	1 6		
Pilot Needle Spring	2980	3	2980	3		
Pilot Needle Spring Catch	2982	2	2982	2		
Nipple Holder for Air Valve	2503	2	2503	2		
Carburettor Cable Nipple	2629	2	2629	2		
Small Plug Screw	2403	3	2403	3		
Adaptor Location Peg	134/105	4	134/105	4		
Outlet Clip for 1 1/8" Outlet	} State Material of Mixing Chamber Body, i.e., Brass or Light Metal	27/073	2 6	—		
Outlet Clip for 1 1/4" Outlet		27/073	2 6	—		
Outlet Clip for 1 3/8" Outlet		—	—	27/072	3 0	
Outlet Clip for 1 1/2" Outlet		—	—	27/072	4 0	
Outlet Clip Screw	1962	9	1962	9		
Air Intake Tube, 1" Bore	} Machined in position with Mixing Chamber Body which should be sent to Amal, Ltd.	175/114	10 0	—		
Air Intake Tube, 1 1/16" Bore		175/113	10 0	—		
Air Intake Tube, 1 1/8" Bore		—	—	175/118	10 0	
Air Intake Tube, 1 5/32" Bore		—	—	185/121	10 0	
Air Intake Tube, 1 3/16" Bore		—	—	175/117	10 0	
Lock Ring for Air Intake Tube	175/115	4 0	175/119	4 0		

AMAL

FLOAT CHAMBER PARTS (Illustrations)

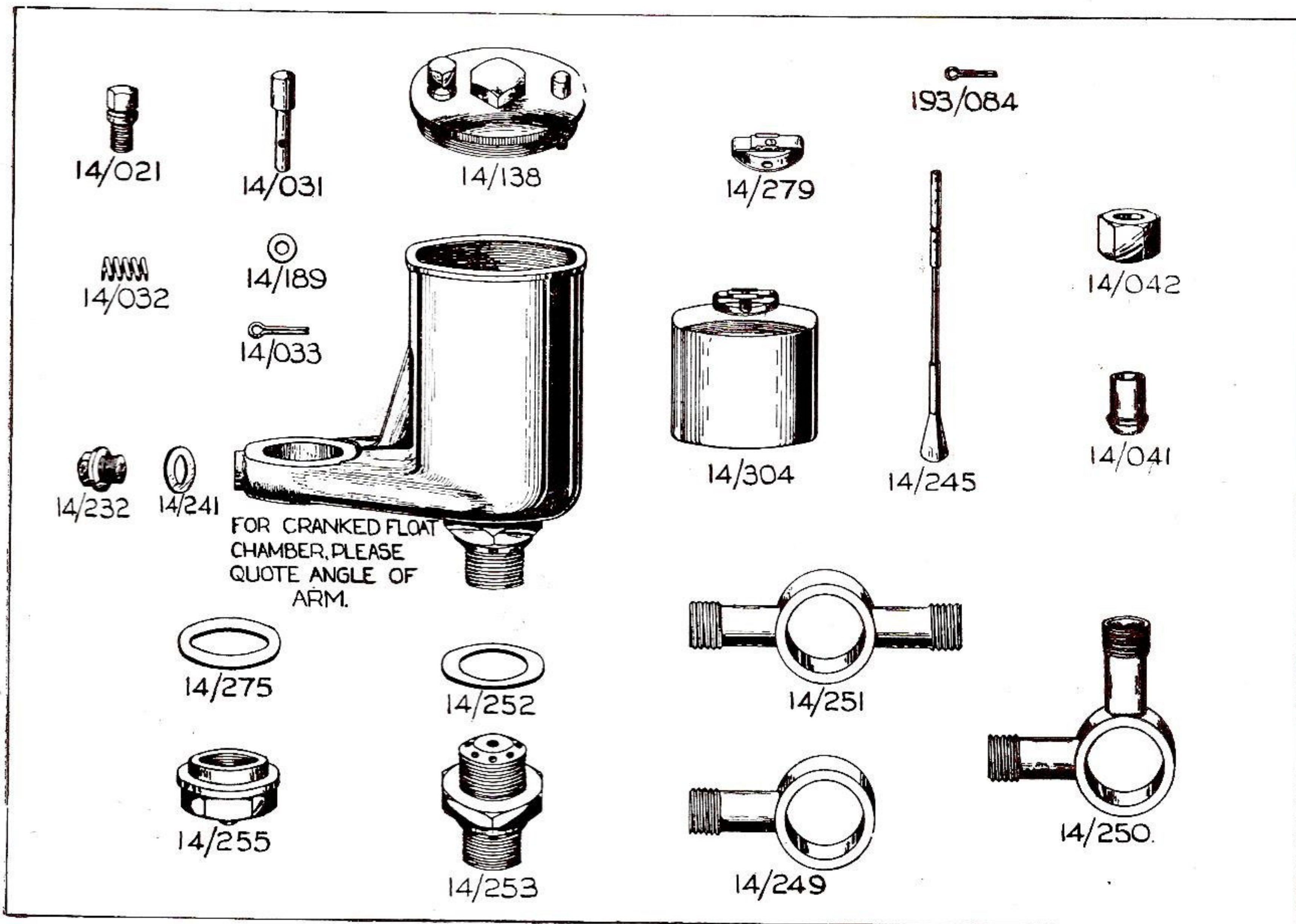

The above illustrations cover Float Chambers
Type Nos. 14/532, 14/533, 14/534, 14/538 and 15/1812.

MOST PARTS OF FLOAT CHAMBERS TYPE No's. 14/064 and 14/601
are common to the above.

Refer to page 4 for full details and prices.

AMAL

Price List of FLOAT CHAMBER PARTS

Component	14/064	14/601	14/532	14/533	14/534	14/538	15/1812	Price s. d.
Float Ch'b'r comp'te	14/064	—	—	—	—	—	—	30 0
Ditto	—	14/601	—	—	—	—	—	60 0
Ditto	—	—	14/532	14/533	—	14/538	—	47 6
Ditto	—	—	—	—	14/534	—	—	43 9
Ditto	—	—	—	—	—	—	15/1812	80 0
Fl't Ch'b'r Body only	14/314	—	—	—	—	—	—	20 0
Ditto	—	14/316	—	—	—	—	15/1812B	40 0
Ditto	—	—	14/225R	14/225R	14/225R	14/217R	—	27 0
For								
Downdraught								
Carbs., please specify Angle								
required for								
Float Chamber								
Arm in addition to part number.								
Cover complete	14/138	14/138	14/138	14/138	14/138	14/138	14/138	3 9
Cover Lock Screw	14/021	14/021	14/021	14/021	14/021	14/021	14/021	4
Tickler	14/031	14/031	14/031	14/031	14/031	14/031	14/031	10
Tickler Spring	14/032	14/032	14/032	14/032	14/032	14/032	14/032	2
Tickler Cotter Pin	14/033	14/033	14/033	14/033	14/033	14/033	14/033	1
Tickler Washer	14/189	14/189	14/189	14/189	14/189	14/189	14/189	1
Float Needle	14/024S	14/024S	—	—	—	—	—	1 6
Float Needle	—	—	14/245	14/245	14/245	14/245	14/245	3 9
Float	14/017	14/017	—	—	—	—	—	3 9
Float	—	—	14/304	14/304	14/304	14/304	14/304	3 9
Float Bow Spring	14/279	14/279	14/279	14/279	14/279	14/279	14/279	4
Float Securing Cotter Pm	—	—	193/084	193/084	193/084	193/084	193/084	1
Needle Valve Seating	—	—	14/253	14/253	14/253	14/253	14/253	5 0
Needle Valve Seating Washer	—	—	14/252	14/252	14/252	14/252	14/252	2
Body Base Plug Screw	—	—	14/232	14/232	14/232	14/232	14/232	6
Washer for Body Base Plug Screw	—	—	14/241	14/241	14/241	14/241	14/241	1
Banjo (Single)	14/035	14/035	—	—	—	—	—	3 0
Banjo (Single)	—	—	—	—	14/249	—	14/249	3 9
Banjo (Twin) 90°	14/043	—	—	—	—	—	—	6 9
Banjo (Twin) 90°	—	—	—	14/250	—	14/250	—	7 6
Banjo (Twin) 180°	14/173	—	—	—	—	—	—	6 9
Banjo (Twin) 180°	—	—	14/251	—	—	—	—	7 6
Washers for Banjo	14/037	14/037	14/275	14/275	14/275	14/275	14/275	2
Banjo Nut	14/036	14/036	—	—	—	—	—	9
Banjo Nut	—	—	14/255	14/255	14/255	14/255	14/255	1 6
Flex. Pipe Connection for Mix. Chbr.	—	—	—	—	—	14/218	—	1 6
Flex. Pipe Connection for Fl. Chbr.	—	—	—	—	—	14/219	—	3 9
Washer for Float Chbr. Connection	—	—	—	—	—	120/036	—	2
Petrol Union Nut	14/042	14/042	14/042	14/042	14/042	14/042	14/042	9
Petrol Union Nipple	14/041	14/041	14/041	14/041	14/041	14/041	14/041	5

AMAL LTD., BIRMINGHAM, England.

Telephone: BIRchfields 4571 (5 lines).

Telegrams: Amalcarb, Birmingham.