

LIST No. 210.

**AMAL**  
**Binks AMAC B&B**  
**Carbureters**

**HINTS,  
TIPS  
AND  
INSTRUCTIONS**





# HINTS AND TIPS BOOKLET

No. 210.

## CONTENTS

	Page
Introduction ... ..	3
<b>CARBURETTER TUNING - GENERAL</b>	
<b>FITTING CARBURETTER</b> ... ..	4
<b>The AMAL Carburetter 1929 :</b>	
1 - Block showing Section View ... ..	6
2 - General description ... ..	7
3 - Construction ... ..	7
4 - How it works ... ..	8
5 - Tuning the AMAL Carburetter ... ..	9
6 - Maintenance ... ..	11
<b>The BINKS Carburetter 1929 :</b>	
1 - Block showing Section View ... ..	12
2 - General description ... ..	12
3 - Construction ... ..	13
4 - How it works ... ..	14
5 - Tuning the BINKS Carburetter ... ..	15
6 - Maintenance ... ..	16
Location of trouble ... ..	16
Settings for AMAL and BINKS Carburetters ... ..	18
List of jets with equivalent giving flow in c.c.s and jet hole diameters ... ..	20
Cubic capacity of Standard engines at present on the road ... ..	21
Approximate engine revolutions at different speeds ... ..	22
Fuels ... ..	23
How to Order Spare Parts ... ..	24
Spare Parts Illustrations ... ..	24
Spare Parts Price List ... ..	26
List of Service Stockists ... ..	29

Telephones ... .. BIRMINGHAM EAST 1371-2-3-4  
 Telegrams ... .. AMALCARB, PHONE, BIRMINGHAM  
 Codes : ... ABC (5th & 6th Editions) Western Union & Bentleys

*Now Manufactured by*



**Amalgamated Carburetters Ltd.**  
 Holford Works, Perry Barr, Birmingham



## 1929 AMAL CARBURETTER

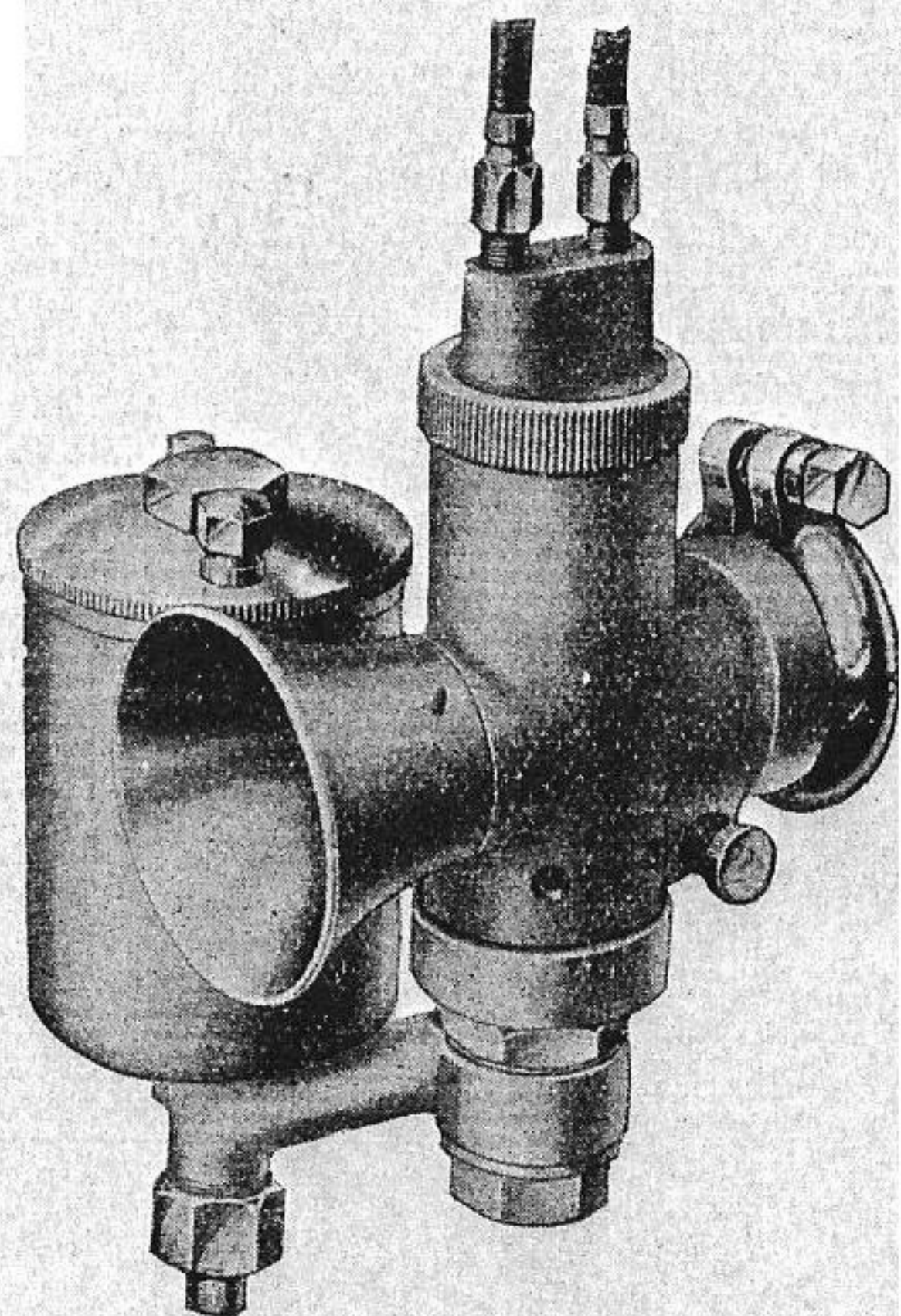

AMAL

## CARBURETTERS *for* 1929

### INTRODUCTION

AMAL Carburetters for 1929 are being made in two distinct types, which will be as follows:

#### 1—THE AMAL CARBURETTER

This is an instrument with a needle controlled main jet similar to the 1928 AMAC Carburetter

#### 2—THE BINKS CARBURETTER

This is similar to the 1928 BINKS 2-jet Carburetter, but it has an improved form of construction.

It is the purpose of this Booklet to give Motor Cyclists general hints concerning Carburetter tuning, and full instructions with regard to the 1929 and AMAL and BINKS Carburetters.



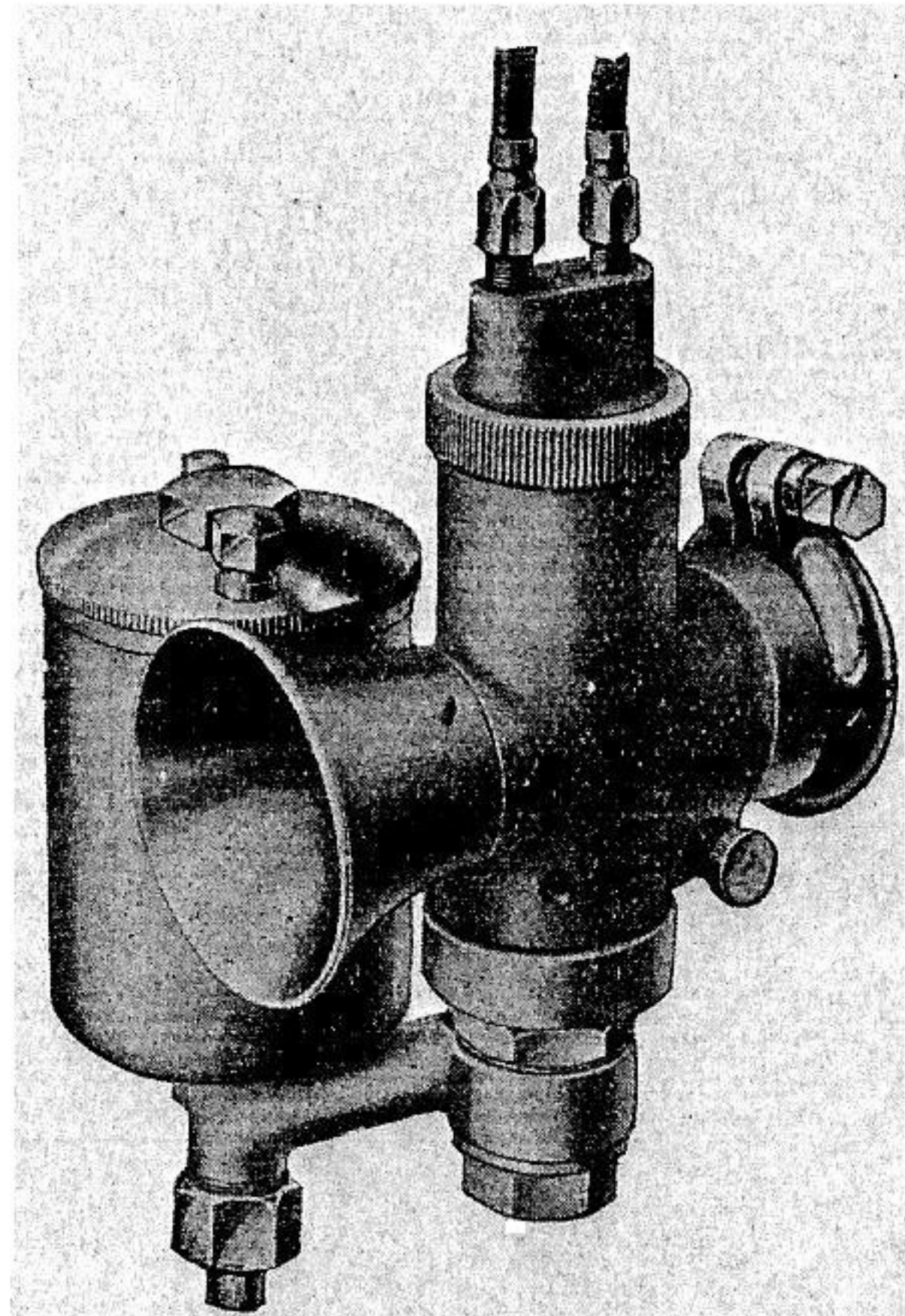

# CARBURETTERS *for* 1929

## INTRODUCTION

AMAL Carburetters for 1929 are being made in two distinct types, which will be as follows:

### 1—THE AMAL CARBURETTER

This is an instrument with a needle controlled main jet similar to the 1928 AMAC Carburetter

### 2—THE BINKS CARBURETTER

This is similar to the 1928 BINKS 2-jet Carburetter, but it has an improved form of construction.

It is the purpose of this Booklet to give Motor Cyclists general hints concerning Carburetter tuning, and full instructions with regard to the 1929 and AMAL and BINKS Carburetters.



## CARBURETTER TUNING (General).

It is of the utmost importance that a carburetter of the correct choke size is selected, and we have no hesitation in saying that our list of Recommended Sizes will meet any ordinary requirements.

Where a carburetter is required for exceptional conditions, such as Track Racing on alcohol fuels, or, to quote the other extreme, for Stationary Engine Work, it is preferable to ask our advice.

Once the correct choke size has been selected, the next procedure is the size of the Main Jet. Generally, the sizes recommended will give satisfaction, but certain conditions necessitate a departure from standard; prominent among these we may mention—excessive heat or cold, due to climatic conditions, or radical departures from standard in the design of the power unit.

In any case, the correct size of the Main Jet is readily determined. The air lever should be set three-quarter open, and a Jet selected which gives the highest maximum speed, or the most power on full throttle.

To determine whether the Jet is too large or too small, with throttle fully open gradually close the air lever. If an increase in speed or power is noticeable, then the jet is on the small size. If, however, when the air lever is opened fully a definite increase in speed or power is obtained, the jet is too large.

**Pilot Jet.** The size of the Pilot Jet on the Amal Carburetter is fixed, and it is unnecessary to attempt any alteration to this. Adjustment for "slow running" is made by means of the knurled screw on the Mixing Chamber side.

On the Binks Model a Pilot Jet must be selected which gives the desired "idling" of the engine when in "neutral," and at the same time enables a correct blend between the Pilot Jet and the Main Jet.

In connection with the foregoing, it is important to remember that the strength of the mixture can always be ascertained by the use of the Air Valve. With the Throttle in a definite position: if an increase in engine revolutions results from closing down the air valve, the mixture is weak; and if on opening the air valve the engine revolutions increase, then the mixture is rich.

General indications of "rich mixture" are—heavy thumpy running, emission of black smoke from the exhaust, the inside of the carburetter becomes blackened, and as the throttle is opened, heavy "blow back" of fuel is observed from the carburetter air intake.

"Weak mixture"—difficult starting, tendency for the engine to fire back through the carburetter, indicated by blue flame from the carburetter air intake. Carburetter becomes sensitive to "drive," and constant use has to be made of the air lever, engine knocks readily and runs hot, with loss of power. The electrode of the sparking plug shows indications of intense heat, and the mica insulation becomes white, polished exhaust pipes become rapidly blued.

(The above applies equally to the AMAL or the BINKS Carburetter.)

## FITTING CARBURETTER (General).

It is essential that the carburetter is fitted vertically, and with an air-tight union to the engine.

**Petrol Pipes and Petrol Cocks.** The Petrol Pipes and Cocks should have a minimum internal bore of  $\frac{3}{16}$  in., and for racing purposes  $\frac{1}{4}$  in. bore is necessary. Any bends in the petrol pipe must run in a downward direction.

**Controls.** Cables must be fitted without acute bends, and care should be taken that the outer casing is not trapped between the moving parts of the spring fork mechanism.



## AMAL CARBURETTER (Section View).

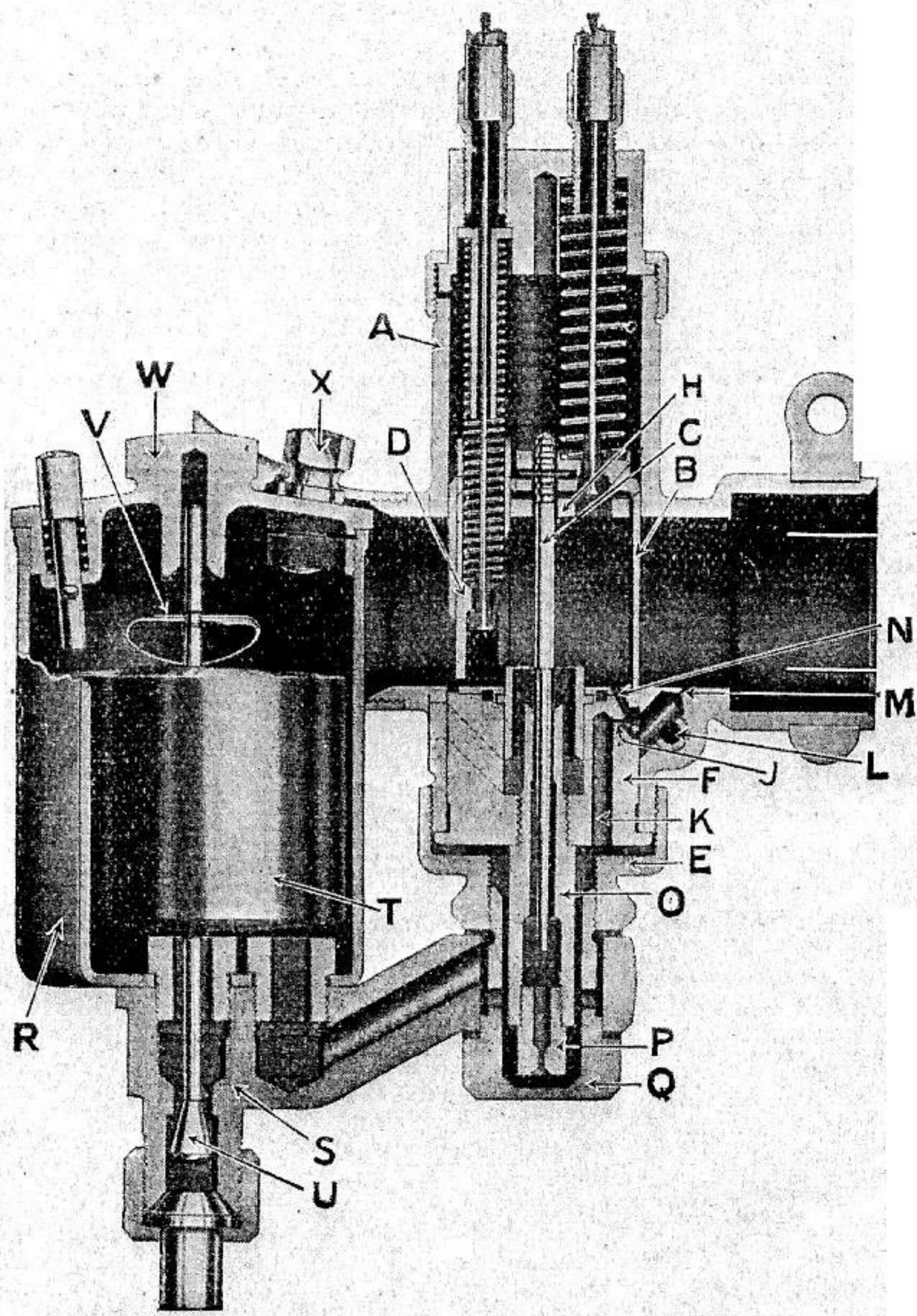

## THE AMAL CARBURETTER 1929 TYPES 4, 5 and 6.

The design of this instrument combines the well-known features of both Amac, and Brown & Barlow Carburetters. The shaped adaptor giving a clear gas passage of high volumetric efficiency is retained.

A constant mixture strength throughout the full range of the throttle valve is obtained by a well-known method of regulating the fuel supply by means of a suitably tapered needle adjustably attached to the throttle valve.

A metered jet is provided to regulate the maximum amount of fuel available at full throttle.

The idling system consists of Pilot Jet and By-pass, provision for adjustment being provided by a small knurled screw readily accessible situated on the mixing chamber side.

The Carburettor can be supplied with a Double or Single Lever Control, which may be cable operated, or for Stationary Engines attached direct to the Carburettor top. The Single Lever pattern is normally fitted with a hand-operated air valve for starting.

For standard Touring and Sports conditions the Carburettor sizes in the tables on pages 18 and 19 will give every satisfaction, and for special conditions, such as racing, our advice is always available.

### CONSTRUCTION OF AMAL CARBURETTER.

Referring to the Sectional Diagram which shows the constructional arrangement, A is the Carburettor Body or Mixing Chamber, the upper part of which is fitted with Throttle Valve B, with Taper Needle C attached by Needle Clip.

The Throttle Valve regulates the quantity of mixture supplied to the Engine.

Passing through the Throttle Valve is the Air Valve D, independently operated and serving the purpose of obstructing the main air passage for "starting" and "mixture regulation."

Attached to the underside of the Mixing Chamber by the Union Nut E is the Jet Block F, and interposed between them a fibre washer to ensure a petrol-tight joint.



On the upper part of the Jet Block is the Adaptor Body H, forming a clean through-way.

Integral with the Jet Block is the Pilot Jet J, supplied through the Passage K.

The adjustable Pilot Air Intake L communicates with a chamber, from which issues the Pilot Outlet M and the By-pass N.

The Needle Jet O is screwed in the underside of the Jet Block, and carries at its bottom end the Main Jet P. Both these Jets are removable when the Jet Plug Q, which bolts the Mixing Chamber and the Float Chamber together, is removed.

The Float Chamber, which can be supplied either Top or Bottom Feed, consists of a Cup R suitably mounted on a Platform S containing the Float T and the Needle Valve U attached by the Clip V.

The Float Chamber Cover W has a Lock Screw X for security.

## HOW IT WORKS.

The Petrol Tap having been turned on, petrol will flow past the Needle Valve U until the quantity of petrol in the Chamber R is sufficient to raise the Float T, when the Needle Valve U will prevent a further supply entering the Float Chamber.

The action of the Float can readily be understood, for, as the quantity of fuel in the Float Chamber is used the Float T will drop, carrying with it the Needle U and admitting a further supply. Thus, automatically, the petrol level is kept constant.

In connection with the Float Chamber, it must be clearly understood that any alteration to our Standard Level can only have detrimental results.

The Float Chamber having filled to its correct level, the fuel passes along the passages through the diagonal holes in the Jet Plug Q, when it will be in communication with the Main Jet P and the Pilot Feed Hole K; the level in these Jets being, obviously, the same as that maintained in the Float Chamber.

Imagine the Throttle Valve B very slightly open. As the piston descends, a partial vacuum is created in the Carburetter, causing a rush of air through the Pilot Air Hole L and drawing fuel from the Pilot Jet J.

The mixture of air and fuel is admitted to the Engine through the Pilot Outlet M.

The quantity of mixture capable of being passed by the Pilot Outlet M is insufficient to run the Engine. This mixture also carries excess of fuel. Consequently, before a combustible mixture is admitted, Throttle Valve B must be slightly raised, admitting a further supply of air from the main air intake.

The further the Throttle Valve is opened, the less will be the depression on the Outlet M, but, in turn, a higher depression will be created on the By-pass N, and the Pilot mixture will flow from this passage as well as from the Outlet M.

As the Throttle Valve is further opened the fuel passes the Main Jet P, and this Jet governs the mixture strength from seven-eighth to full throttle.

For intermediate throttle positions the Taper Needle C working in the Needle Jet O is the governing factor.

The further the Throttle Valve is lifted, the greater the quantity of air admitted to the engine, and a suitable graduation of fuel supply is maintained by means of the Taper Needle.

The Air Valve D, which is cable-operated on the Two-Lever Carburetter and Hand-operated on the Single-Lever Carburetter, has the effect of obstructing the main through-way, and, in consequence, increasing the depression on the Main Jet, enriching the mixture.

## TUNING THE AMAL CARBURETTER.

Having obtained the correct jet size, as described in our opening paragraph on general tuning, the Throttle Valve should then be practically closed; and if the Engine is cold, the Float Chamber flooded and the Air Lever closed.

Start the Engine and place the gear lever in "Neutral" and warm up. If the engine revolutions are too high, reduce these further by closing the Throttle Valve slightly, and turn the knurled-headed screw on the mixing chamber side until even and regular firing of the engine is secured.

It will be noticed that any variation of the Throttle Valve position will necessitate a readjustment of the Pilot Air Screw until a satisfactory adjustment and good idling is secured.



If difficulty is experienced in obtaining good "slow running," the trouble will invariably be traced to one of the undermentioned causes:

Air leaks at the junction of the Carburetter and the Engine.

Spark Plug oily, or points incorrectly set.

Faulty Valve Guides or Seatings.

Faulty Magneto, giving weak spark.

For the foregoing adjustments it is best to retard slightly the Magneto.

**Taper Needle.** From the "slow running" position up to seven-eighth throttle, the regulation of the mixture strength is governed by the Taper Needle.

Five grooves will be found in the head of the Needle, by which the Needle is attached to the Throttle Valve by means of a Spring Clip.

For all "normal running" the middle groove will be found the most suitable, but if it is desired to obtain maximum economy the needle may be lowered to the second groove from the top.

For racing and sports conditions, where petrol consumption is of no moment, and maximum acceleration is desired, a slightly richer mixture will give the required results, and the needle may then be raised to the fourth, or, under exceptional circumstances, the 5th groove.

**Throttle Valve.** Our Standard Valve is No. 5, which denotes that the back of the Throttle Valve on the air intake side is cut away for  $\frac{5}{16}$  in, measured from the base of the valve.

For Twin-cylinder Engines No. 4 Valve, indicating  $\frac{1}{4}$  in. cut-away is usually preferable. Other than this no alteration whatever should be necessary to the Standard Valve supplied.

**NOTE.**—We do not advise modifications to our settings as supplied to manufacturers of motor cycles.

## SINGLE LEVER.

The Single Lever Automatic Carburetter is of exactly the same general design, but the Air Valve is operated by a Rod Control fitted in the Mixing Chamber Top.

There are two positions for this Valve: "Closed" for starting, and "Fully Open" for all general running.

Exactly the same tuning instructions apply for both the Single and Double-Lever Carburetter.

## MAINTENANCE OF THE AMAL CARBURETTER.

It is essential, to obtain the best results, that the working parts of the Carburetter are given a periodical cleaning. The Float Chamber Cover W should be unscrewed, after first loosening the Lock Screw X, withdraw the Float by pinching the Clip V inwards, at the same time pulling it gently upwards.

Any sediment or water which has collected in the bottom of the Float Chamber can then be removed.

Ascertain that the Needle Head U and the Seating are kept free from all traces of foreign matter.

Under no conditions attempt to regrind the Needle Seating, or both the Needle and the Float Chamber will be ruined.

Unscrew the knurled cap holding the Mixing Chamber Top in position, when the Throttle Valve, complete with Taper Needle, and the Air Valve can be withdrawn from the Carburetter.

These should be swilled in clean petrol or paraffin, and on no account should be lubricated.

The Jet Bolt Q must be unscrewed, when the Float Chamber can be removed complete from the Mixing Chamber Body.

Any sediment in the bottom of the Jet Bolt must, of course, be removed.

Unscrew the Main Jet P and the Needle Jet O, and see that these are free from obstruction.

The large Union Nut E holding the Jet Block in position may then be detached, preferably by means of a box or fixed spanner.

The Jet Block may then be pushed out, and the Pilot Orifice J will be exposed. Ascertain that this is clear by blowing through it; and if found obstructed, this must on no account be cleared by any instrument likely to enlarge the size of the hole.

The parts having been suitably cleaned, the Carburetter can then be erected, care being taken that the Union Nut E is securely locked, and that the fibre washer on the inner face of this is not omitted.

In replacing the Throttle Valve, make sure that the Needle enters the central hole in the adaptor top, and on no account make use of brute force, otherwise the Needle will be damaged. This operation is best carried out with both the Air Lever and Throttle Lever in the "closed" position.

When refitting the Jet Plug, note that one washer is fitted above the float chamber lug and one underneath.



## THE BINKS CARBURETTER, 1929 TYPES 7, 8 and 9.

The BINKS Carburetters, while modified in design for the 1929 season to improve the construction, still retain the original Binks' characteristics. Prominent among these we may mention—simplicity, reliability, and ease of tuning. The Carburetter also combines the excellent qualities of being eminently suitable for touring, sports, and racing conditions.

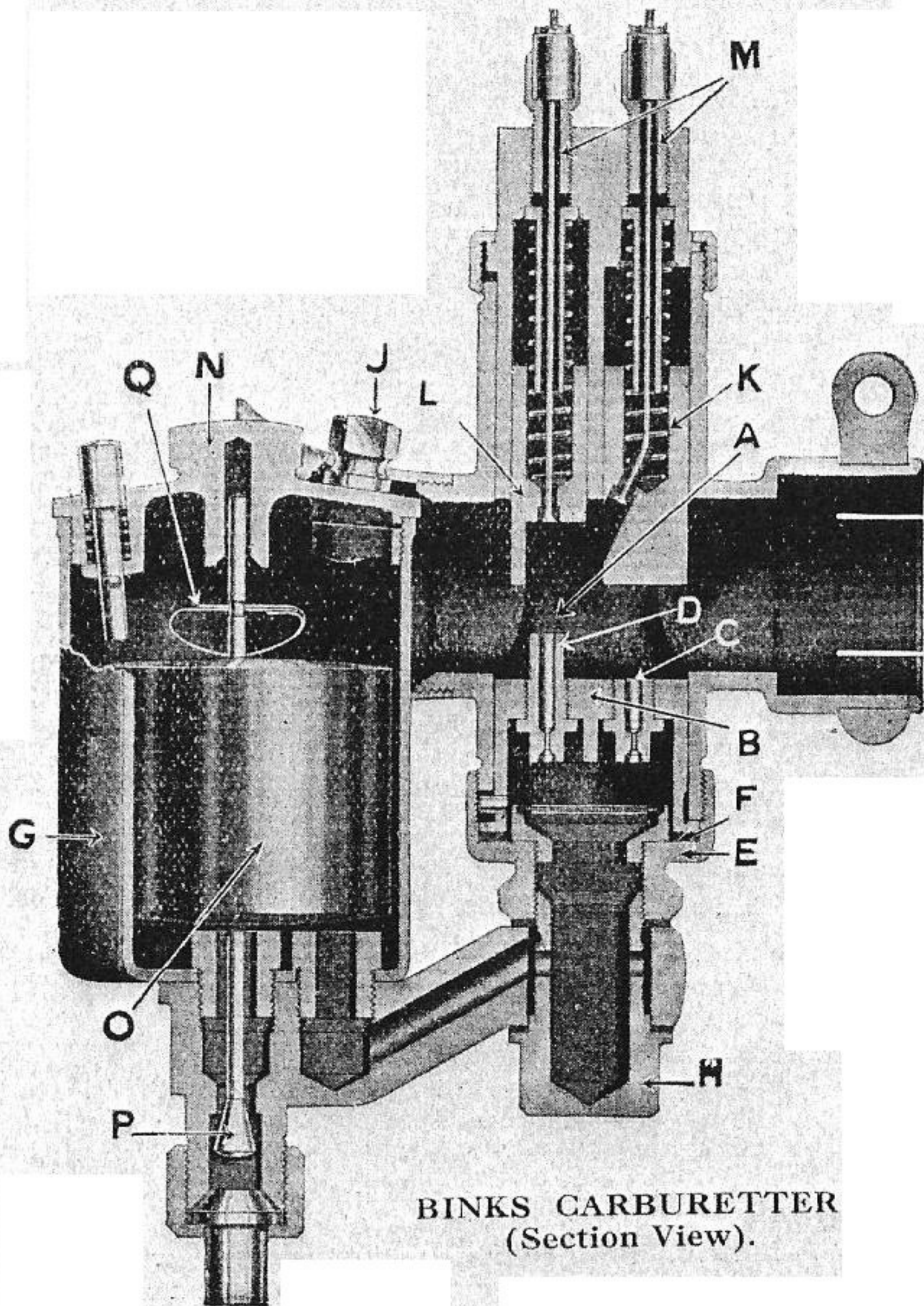

BINKS CARBURETTER  
(Section View).

The Carburetter is a Two-jet Pattern, as we have found all possible conditions can be met by a suitable arrangement of two jets only.

The Pilot Jet regulates the mixture strength for "slow running" and "intermediate" positions of the throttle.

The Main Jet, which is situated near the air intake, comes into action when unmasked by the throttle valve, and regulates the mixture strength from there up to full throttle.

Thus, once the correct choke size has been selected, there are only two Variables for tuning the correct size of the main and pilot jets.

The Carburetter can be supplied with Double or Single Lever Control, which may be Bowden operated, or, for Stationary Engines, attached direct to the Carburetter Top.

The Double Lever Carburetter is fitted with Handlebar Control to the Air Valve for starting and mixture regulation, and the Single Lever Pattern is normally fitted with an Air Valve controlled by a rod on the Mixing Chamber Top.

For standard touring and sports conditions the Carburetter Sizes in the tables on pages 18 and 19 will give every satisfaction; while for special conditions, such as racing, our advice is always available.

### BINKS CONSTRUCTION.

Referring to the Sectional Diagram which illustrates the constructional arrangement, A is the Carburetter Body (or Mixing Chamber), to the underside of which is attached by the Union Nut E the Jet Block B, a Fibre Washer F being interposed between them to ensure a petrol-tight joint.

Screwed into the Jet Block are the Pilot Jet C and the Main Jet D.

The upper portion of the Mixing Chamber carries the Throttle Valve K, which regulates the quantity of mixture supplied to the Engine and the Air Valve L to give easy starting and mixture control.

The Jet Plug H secures the Carburetter Body to the Float Chamber G, which can be supplied with either Top or Bottom Feed.

The Needle Valve P is positively attached to the Float O by means of the Clip Q.

The Float Chamber Cover N has a Lock Screw J for security.



## BINKS CARBURETTER. HOW IT WORKS.

The petrol tap having been turned on, petrol will flow past the Needle Valve P until the quantity of petrol in the Float Chamber G is sufficient to raise the Float O, when the Needle Valve P will prevent a further supply entering the Float Chamber.

The action of the Float can readily be understood, for, as the quantity of fuel in the Float Chamber is used, the Float O will drop, carrying with it the Needle P and admitting a further supply.

Thus, automatically, the petrol level is kept constant.

In connection with the Float Chamber, it must be clearly understood that any alteration to our standard level can only have detrimental results.

The Float Chamber having filled to its correct level, the fuel passes along the passages through the diagonal holes in the Jet Plug H, when it will be in communication with the Main Jet D and the Pilot Jet C, the level in these jets being, obviously, the same as that maintained in the Float Chamber.

Imagine the Throttle Valve K very slightly open. As the piston descends, a partial vacuum is created in the Carburetter, causing a rush of air through the throughway A and drawing fuel from the Pilot Jet C. The Pilot Jet, being situated immediately beneath the base of the Throttle Valve, is subjected to a heavy depression, so as to obtain the necessary mixture for Idling and small loads.

In the case of the Main Jet D, which is the longer of the two, and situated near the Carburetter Air Intake, at small throttle openings it is inoperative, and the mixture is governed entirely by the size of the Pilot Jet.

The Throttle K being almost closed, it will be seen that the Pilot Jet C is situated in an extremely restricted area. In consequence, the passage of the air from the main through-way will be restricted, and at the same time a high depression will exist on the Pilot C. At this position of the Throttle, it will readily be seen that not only is the Main Jet D shrouded by the Throttle Valve, but also the area of the Mixing Chamber in which it is housed is infinitely bigger than the area of the through-way exposed to the suction of the Engine, in consequence of which no fuel is drawn from the Main Jet.

As the Throttle Valve K is raised, the area immediately above the Pilot Jet C is increased, and in consequence the suction or depression on this Jet diminishes, and at the same time increases on the Main Jet, so a balance between the two Jets is obtained throughout the whole range.

## TUNING THE BINKS CARBURETTER.

To obtain the best results, it is essential that the correct bore size is selected, the correct Pilot Jet size, and the correct Main Jet size.

**Bore Size.** We always advise use being made of our Table of Settings, which gives the correct bore for anything but abnormal conditions.

**Pilot Jet.** This affects "slow running" and slow pulling only, and the smallest size should be selected which gives the best Idling. At the same time, care must be taken not to reduce the size of the Pilot Jet unduly, otherwise difficulty will be experienced in obtaining a correct blend with the Main Jet.

**Main Jet.** The selection of the correct Main Jet is dealt with on the opening page of our Booklet, under "General Carburetter Tuning," and it will be noted that for touring conditions we advise this to be obtained with the Air Lever three-quarter open.

**Blend of Main and Pilot.** If any trouble is experienced due to a weak spot between the Pilot and Main Jet, it can usually be cured by increasing the Pilot Jet one size.

**Starting up.** With a *cold Engine*, depress the Carburetter Tickler, close Air Valve, open Throttle about one-eighth, ignition about three-quarter advanced, when, if the ignition system is in good order, no difficulty should be experienced in obtaining an "easy start."

With a *warm Engine* it is unnecessary to flood Carburetter, but the Air Lever should be closed.

If the Float Chamber is unduly flooded, excessive richness of mixture will prevent the engine starting. Open Throttle fully and revolve Engine smartly until excess of fuel is exhausted; then proceed as before, without again flooding.

### IMPORTANT.

**Throttle Valves.** A number will be found stamped on the base of the Throttle Valve, and a corresponding number on the right-hand side of the Mixing Chamber (looking from the Air Intake).

These numbers must always correspond: A No. 17 Carburetter must have a No. 17 Throttle Valve, and so on throughout the range.



## MAINTENANCE OF THE BINKS CARBURETTER.

The Float Chamber should be periodically cleaned out, having previously been detached from the Carburetter by unscrewing the Jet Plug H.

Unscrew the Locknut J, when the Float Chamber Cover N will be detached. By pressing the Bow Clip Q gently inwards, at the same time pulling upwards, the Float can be withdrawn from the Chamber.

Any sediment which may have collected in the bottom of the Chamber should be removed, and the Float Needle P and its seating carefully cleaned. On replacing the Float, make sure that the Clip Q is fitted in the groove in the Needle provided for it.

Obstruction of the Jets is not likely to occur, as a Filter is fitted on the upper side of the Union Nut E, which can be readily unscrewed. The Filter should then be detached and thoroughly swilled out in petrol.

The Jet Block B is a push fit in the Carburetter Body, and can be removed as well as both the Pilot Jet C and the Main Jet D, which are screwed into the latter.

The Throttle and Air Valves K and L are removable on unscrewing the knurled ring holding the Mixing Chamber Top into position.

Apart from keeping these Valves clean, no further attention should be necessary to this part of the Carburetter.

**NOTE.**—It is important, when ordering Spare Parts, that the number stamped on the Mixing Chamber side is quoted. 1929 Binks Jets are not interchangeable with those of other years.

## LOCATION OF TROUBLE.

### ENGINE STOPS SUDDENLY.

As far as the Carburetter is concerned, this can only be caused by—

- (1) Shortage of fuel.
- (2) Broken or obstructed petrol pipes
- (3) Tank cock inadvertently closed.
- (4) Obstructed jets.
- (5) Broken or detached throttle valve cable.

All these points are readily checked by depressing the Float Chamber Tickler, when, if the Carburetter is in order, petrol will be seen to emerge from the Main Jet; at the same time ascertain that the Throttle Valve is working.

If no petrol issues from the Carburetter when the Tickler is depressed, ascertain that there is fuel in the tank. Remove petrol pipe union from Float Chamber: if no flow, either pipe or petrol cock is obstructed, the cure for either being obvious.

If this is in order, remove Float Chamber Cover and see that the Float Needle is not bent and is working smoothly. Withdraw the Float and inspect Float Chamber for water or foreign matter.

The passage in the Float Chamber neck may also be tested for obstruction.

If the foregoing are in order, it will be necessary to remove the Main Jet, as described in our previous paragraph on "Maintenance."

It is very seldom that the Carburetter is the cause of an Engine stopping suddenly, unless due to fuel shortage.

### MIS-FIRING DUE TO EXCESS OR LACK OF FUEL.

**Excess of Fuel.** Punctured Float, foreign matter between Needle Valve and Seating, Needle Clip out of position, Main Jet or Needle Jet unscrewed, Mixing Chamber Union Nut loose, causing a leakage of petrol round jet block.

The remedies for above are self-explanatory.

**Lack of Fuel.** Partial obstruction of Fuel Supply; obstruction in Carburetter Passages or in Jets. If the obstruction is only due to water or small foreign bodies in the Jets, this can frequently be cured by placing the palm of the hand over the Air Intake of the Carburetter when the Engine is running, at the same time opening the Throttle Lever.

The Engine will cease to fire for a few seconds, and then, if the obstruction is cleared, will resume firing regularly. If this is of no avail, the fuel line and Float Chamber must then be inspected, as directed in the paragraph dealing with "Engine Stops Suddenly."

If this is unavailing, the only procedure is to remove the Jets and clear the obstruction.



## AMAL CARBURETTERS 1929.

### Standard Settings 4 Stroke Single Cylinder Engines

#### AMAL

#### BINKS

ENGINE.	Carb. Type.	Jet.	Needle Pos.	Model Valve	Carb. Type.	Pilot Jet.	Main Jet.	Valve
<b>175 c.c.—</b>								
S.V. Touring	17A	60	3	4/5	17B	30	60	17
O.H.V. Touring	17A	60	3	4/5	17B	30	60	17
O.H.V. Sports	21A	70	3	4/5	21B	30	70	21
O.H.V. Racing	25A	80	4	4/5	25B	30	90	25
O.H.V. Track	28A	90	4	5/5	28B	30	95	28
<b>250 c.c.—</b>								
S.V. Touring	21A	70	3	4/5	21B	30	70	21
O.H.V. Touring	25A	80	3	4/5	25B	30	80	25
O.H.V. Sports	25A	80	3	4/5	25B	30	80	25
O.H.V. Racing	28A	100	4	5/5	28B	30	95	28
O.H.V. Track	33A	110	4	5/5	33B	30	100	33
<b>300 c.c.—</b>								
S.V. Touring	21A	70	3	4/5	21B	30	70	21
<b>350 c.c.—</b>								
S.V. Touring	25A	80	3	4/5	25B	30	80	25
O.H.V. Touring	25A	80	3	4/5	25B	30	80	25
O.H.V. Touring	28A	100	3	5/5	28B	30	85	28
O.H.V. Sports	33A	110	3	5/5	33B	30	95	33
O.H.V. Sports	39A	130	3	6/5	39B	40	110	39
O.H.V. Racing	45A	170	4	6/5	45B	40	130	45
O.H.V. Track	45A	170	4	6/5	45B	40	130	45
<b>500 c.c.—</b>								
S.V. Touring	33A	110	3	5/5	33B	30	95	33
S.V. Touring	39A	130	3	6/5	39B	40	110	39
O.H.V. Touring	45A	150	3	6/5	45B	40	120	45
O.H.V. Sports	45A	150	3	6/5	45B	40	120	45
O.H.V. Sports	51A	170	3	6/5	51B	40	140	51
O.H.V. Racing	51A	190	4	6/5	51B	40	150	51
O.H.V. Track	T10md							
<b>600 c.c.—</b>								
S.V. Touring	39A	130	3	6/5	39B	40	110	39
S.V. Touring	45A	150	3	6/5	45B	40	120	45
O.H.V. Touring	51A	170	3	6/5	51B	40	140	51
O.H.V. Sports	51A	170	3	6/5	51B	40	140	51
O.H.V. Racing	T10md	170						
O.H.V. Track	T10md							

## AMAL CARBURETTERS 1929.

### Standard Settings 4 Stroke Twin Cylinder Engines

#### AMAL

#### BINKS

ENGINE.	Carb. Type.	Jet.	Needle Pos.	Model Valve	Carb. Type.	Pilot Jet.	Main Jet.	Valve
<b>350 c.c.—</b>								
S.V. Touring	17A	60	3	4/4	17B	30	60	17
O.H.V. Touring	17A	60	3	4/4	17B	30	60	17
O.H.V. Sports	21A	70	3	4/4	21B	30	70	21
O.H.V. Racing	25A	80	4	4/4	25B	30	90	25
O.H.V. Track	28A	90	4	5/4	28B	30	95	28
<b>500 c.c.—</b>								
S.V. Touring	21A	70	3	4/4	21B	30	70	21
O.H.V. Touring	25A	80	3	4/4	25B	30	80	25
O.H.V. Sports	25A	80	3	4/4	25B	30	80	25
O.H.V. Racing	28A	100	4	5/4	28B	30	95	28
O.H.V. Track	33A	110	4	5/4	33B		100	33
<b>750 c.c.—</b>								
S.V. Touring	25A	80	3	4/4	25B	30	80	25
O.H.V. Touring	25A	80	3	4/4	25B	30	80	25
O.H.V. Touring	28A	100	3	5/4	28B	30	85	28
O.H.V. Sports	33A	110	3	5/4	33B	30	95	33
O.H.V. Sports	39A	130	3	6/4	39B	40	110	39
O.H.V. Racing	45A	170	4	6/4	45B	40	130	45
O.H.V. Track	45A	170	4	6/4	45B	40	130	45
<b>1000 c.c.—</b>								
S.V. Touring	33A	110	3	5/4	33B	30	95	33
S.V. Touring	39A	130	3	6/4	39B	40	110	39
O.H.V. Touring	45A	150	3	6/4	45B	40	120	45
O.H.V. Sports	45A	150	3	6/4	45B	40	120	45
O.H.V. Sports	51A	170	3	6/4	51B	40	140	51
O.H.V. Racing	51A	190	4	6/4	51B	40	150	51
O.H.V. Track	T10md							



All Jets are now known by their actual flow when measured by B.E.S.A. standards, and for the sake of clearness for those who are used to think of them in sized holes, the approximate equivalent sizes are given below: Also for old type Amac and Binks Jets.

Flow in C.C.'s.	Jet Dia.	Amac No.	Binks No.
15	—	—	0
20	.015"	—	1
25	—	16	2
30	.018"	18	3
35	—	19	4
40	.021"	20	—
45	—	21	—
50	.024"	23	5
55	—	24	—
60	.026"	25	6
65	—	26	—
70	.028"	27	7
75	—	28	—
80	.030"	29	8
85	—	—	—
90	.032"	30	9
95	—	31	—
100	.034"	32	11
110	.035"	33	13
120	.037"	35	14
130	.038"	36	15
140	.040"	38	16
150	.041"	39	17
160	.043"	40	18
170	.044"	41	19
180	.045"	43	20
200	.048"	45	21
220	.050"	47	22
240	.052"	49	23
260	.055"	51	24
280	.057"	53	25
300	.059"	55	26
325	—	57	—
350	—	59	—

**NOTE.**—1929 Amal and Binks Jets are not interchangeable with those of other years' manufacture.

**CUBIC CAPACITY** of Standard Size of Engines at present on the road.

Millimetres.	C.C.'s.	Millimetres.	C.C.'s.
44 × 44	69	72 × 85.5	349
51 × 51	104	72 × 91	370
51 × 57	116	73 × 70	293
52 × 52	110	74 × 81	349
54 × 75	172	74 × 93	400
55 × 56	133	74.5 × 68	295
55 × 60	142	75 × 79	349
55 × 62	147	76 × 65.5	298
55 × 90	214	76 × 77	348
56 × 61	150	76 × 82	372
59 × 98	268	76 × 85	386
59 × 100	273	77 × 105	489
60 × 60	170	79 × 100	490
60 × 61	172	80 × 98	493
60 × 70	198	82 × 94	496
60 × 74	209	82 × 112	592
60 × 75	212	82 × 120	633
60 × 76	215	82.5 × 93	497
60 × 88	249	84 × 89	493
60 × 90	254	84 × 90	499
62 × 70	211	84 × 100	555
62 × 90	272	84.5 × 88.9	499
63 × 80	249	85 × 65	370
63 × 88	274	85 × 85	482
64 × 70	225	85 × 88	499
64 × 77	248	85 × 97	550
65 × 75	249	86 × 96	558
67 × 70	247	86.4 × 85	499
68 × 76	276	87 × 100	594
69 × 80	299	87 × 110	654
69 × 93	348	87.3 × 101	604
70 × 64.5	248	88 × 85	516
70 × 70	269	88 × 95	578
70 × 76	293	89 × 89	554
70 × 90	346	89 × 96	597
71 × 88	348	89 × 120	746
72 × 72	293	90 × 77.5	493
72 × 76	309	90 × 85	543

In the case of Multi-cylinder Engines, multiply by the number of cylinders.



APPROXIMATE ENGINE REVOLUTIONS  
at different Speeds—Miles per Hour.

Diameter of Driving Wheels, 26in.

m.p.h.	GEAR RATIO.														
	3 $\frac{3}{4}$	4	4 $\frac{1}{4}$	4 $\frac{1}{2}$	4 $\frac{3}{4}$	5	5 $\frac{1}{4}$	5 $\frac{1}{2}$	5 $\frac{3}{4}$	6	6 $\frac{1}{4}$	6 $\frac{1}{2}$	6 $\frac{3}{4}$	7	
5	242	259	275	291	307	323	339	356	372	388	404	420	436	452	
10	485	517	549	582	614	646	679	711	743	776	808	840	873	905	
15	727	775	824	873	921	970	1018	1066	1115	1164	1212	1261	1309	1357	
20	969	1034	1098	1164	1228	1293	1358	1422	1487	1552	1616	1681	1745	1810	
25	1212	1293	1373	1455	1535	1616	1697	1778	1859	1940	2020	2101	2181	2262	
30	1454	1550	1648	1746	1842	1940	2036	2132	2230	2328	2424	2521	2618	2714	
35	1697	1810	1923	2037	2149	2262	2375	2488	2602	2716	2828	2941	3054	3166	
40	1939	2068	2196	2328	2456	2586	2716	2844	2974	3104	3232	3362	3490	3620	
45	2182	2327	2471	2619	2763	2909	3055	3200	3346	3492	3636	3782	3926	4072	
50	2424	2586	2747	2909	3070	3232	3394	3555	3717	3879	4040	4202	4363	4525	
55	2666	2845	3022	3200	3377	3555	3733	3911	4089	4267	4444	4622	4799	4977	
60	2908	3100	3296	3492	3684	3878	4072	4264	4460	4656	4848	5042	5236	5428	
65	3150	3359	3571	3783	3991	4201	4411	4620	4832	5044	5252	5462	5672	5880	
70	3394	3620	3846	4074	4298	4524	4750	4976	5204	5432	5656	5882	6108	6332	
75	3638	3879	4121	4365	4605	4847	5089	5332	5576	5820	6060	6303	6544	6784	
80	3876	4136	4392	4656	4912	5172	5432	5688	5948	6208	6464	6724	6980	7240	
85	4118	4395	4667	4947	5219	5495	5771	6044	6320	6596	6868	7144	7416		
90	4364	4654	4942	5238	5526	5818	6110	6400	6692	6984	7272				
95	4606	4913	5217	5529	5833	6141	6449	6756	7064	7372					
100	4848	5172	5494	5818	6140	6464	6788	7110							

For 24in. Wheels, multiply revolutions 1.08  
" 28in. " " 0.93

FUELS.

The Jet Sizes given in the Table of Carburetter Settings are suitable for Petrol, Benzole, Ethyl Petrol or Petrol-Benzole Mixtures.

For Alcohol Fuels.

On the Amal Carburetter the Needle Jet D must be fitted as well as the following increase in Main Jet sizes.

On the Binks Carburetter both Main and Pilot Jets should be increased in accordance with the following table :

Petrol and Petrol-Benzole, C.C.	P.M.S.2 and R.D.2.	R.D.1.
25	40	45
30	45	55
35	55	65
40	60	75
50	80	90
60	95	110
70	110	130
80	120	150
90	140	170
100	160	180
120	180	220
140	220	260
160	260	300
180	280	325
200	300	375
220	350	400
240	375	450
260	400	475
280	450	525
300	475	550
325	500	600
350	550	650



## Section 12: How To Order Spare Parts.

When ordering Spare Parts it is always advisable to give the make, date and horse-power of the machine for which they are required.

If a part is ordered by telegram, the Part No. could be given, and this number can be found by the following method:

- (1) Note Type No. of Carburetter, which will be found stamped on the Mixing Chamber.
- (2) Look for part required on the Spares illustration in this booklet and note number against it. You may find several numbers against the part, which is due to the fact that it is made in several sizes.
- (3) Glance down Spares Price List until the part is found, and look for its price under the column which is headed with the Type No. of the Carburetter you have.

**NOTE** that in this Spares List all parts bearing the same number are interchangeable.

**Throttle Valve, Jets and Mixing Chambers.**—Care should be taken when these parts are being ordered, and particulars of the machine should always be given.

**Control Spares.**—A separate Leaflet, No. 200, can be supplied, which deals fully with all Amal Controls, Twist Grips and Spare Parts for them.

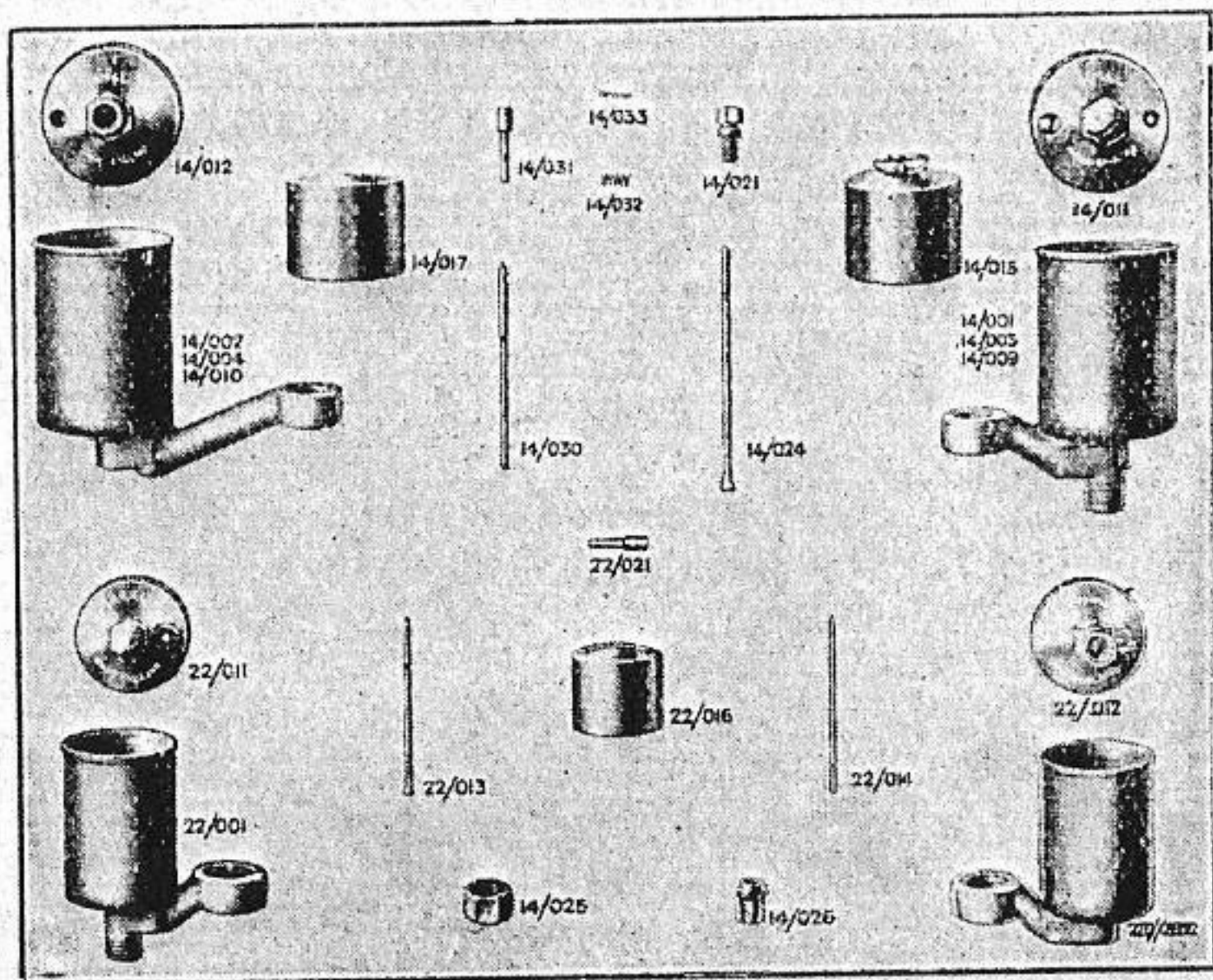

Spare Parts of Float Chambers

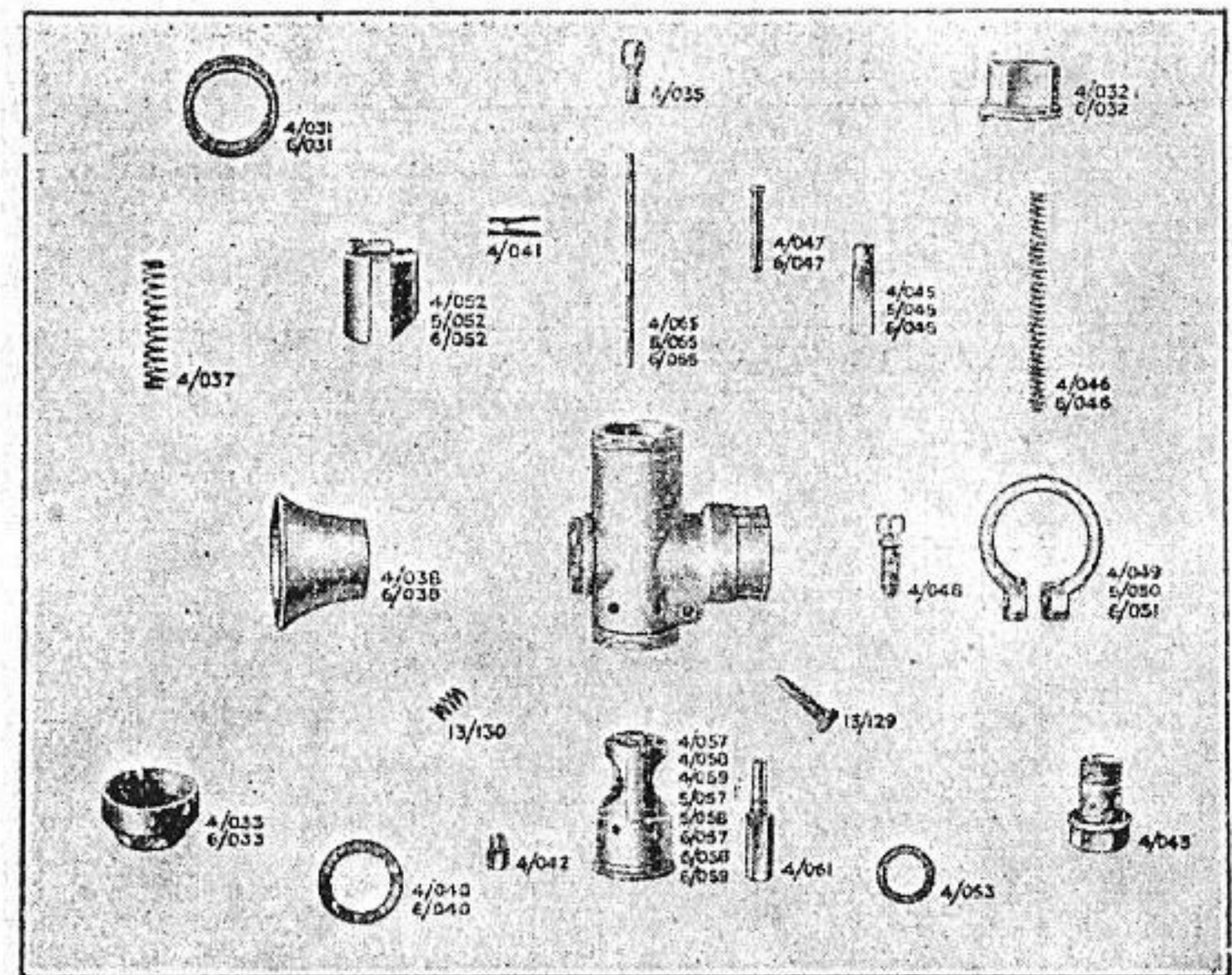

Amal Mixing Chamber Parts

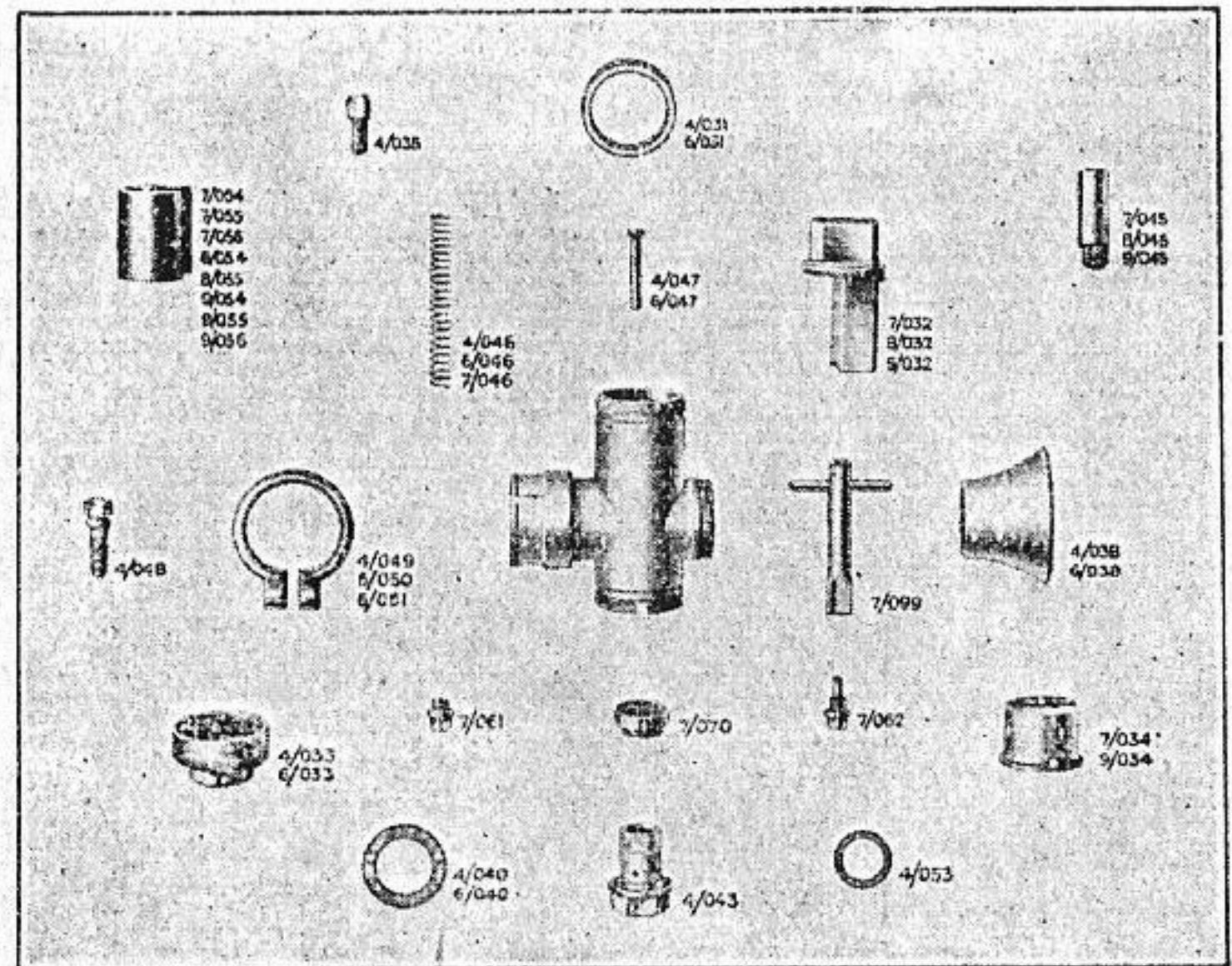

Binks Mixing Chamber Parts



Errata.  
Throttle Valve Spring  
should read 3d.

### MIXING CHAMBER PARTS.

NAME OF PART.	PART NUMBERS.						PRICE.	
	AMAL CARBURETTERS.			BINKS CARBURETTERS.				
	Type 4.	Type 5.	Type 6.	Type 7.	Type 8.	Type 9.	s.	d.
Mixing Chamber ... ..	According to engine.	—	—	According to engine.	—	—	8	0
" " ... ..	According to engine.	—	—	According to engine.	—	—	10	0
" " ... ..	According to engine.	—	—	According to engine.	—	—	12	0
Jet Block and Barrel complete,								
Size 17 ... ..	4/057	—	—	—	—	—	5	0
" 21 ... ..	4/058	—	—	—	—	—	5	0
" 25 ... ..	4/059	—	—	—	—	—	5	0
" 28 ... ..	—	5/057	—	—	—	—	5	0
" 33 ... ..	—	5/058	—	—	—	—	5	0
" 39 ... ..	—	—	6/057	—	—	—	5	0
" 45 ... ..	—	—	6/058	—	—	—	5	0
" 51 ... ..	—	—	6/059	—	—	—	5	0
Jet Block (Binks) ... ..	—	—	—	7/034	7/034	9/034	1	6
Mixing Chamber Union Nut ...	4/033	4/033	6/033	4/033	4/033	6/033	1	6
" " Cap ... ..	4/031	4/031	6/031	4/031	4/031	6/031	1	9
" " Top ... ..	4/032	4/032	6/032	7/032	8/032	9/032	1	9
Cable Adjusters ... ..	4/035	4/035	4/035	4/035	4/035	4/035		4
" Nipples ... ..	4/036	4/036	4/036	4/036	4/036	4/036		2
Throttle Valve Spring ... ..	4/037	4/037	4/037	4/046	4/046	6/046	3	10
Air Funnel ... ..	4/038	4/038	6/038	4/038	4/038	6/038	2	6
Washer for Jet Block ... ..	4/040	4/040	6/040	4/040	4/040	6/040		2
Spring Clip for Needle ... ..	4/041	4/041	4/041	—	—	—		4
Holding Bolt ... ..	4/043	4/043	4/043	4/043	4/043	4/043	2	0

### MIXING CHAMBER PARTS—Continued.

NAME OF PART.	PART NUMBERS.						PRICE.	
	AMAL CARBURETTERS.			BINKS CARBURETTERS.				
	Type 4.	Type 5.	Type 6.	Type 7.	Type 8.	Type 9.	s.	d.
Air Valve ... ..	4/045	5/045	6/045	7/045	8/045	9/045	2	6
Air Valve Spring ... ..	4/046	4/046	6/046	7/046	4/046	6/046		3
Air or Throttle Valve Guide ...	4/047	4/047	6/047	4/047	4/047	6/047		2
Outlet Clip Screw ... ..	4/048	4/048	4/048	4/048	4/048	4/048		6
Outlet Clip, 1in. ... ..	4/049	4/049	—	4/049	4/049	—	1	9
" " 1½in. ... ..	—	5/050	5/050	—	5/050	5/050	1	9
" " 1½in. ... ..	—	—	6/051	—	—	6/051	1	9
Throttle Valve ... ..	4/052	5/052	6/052	Type 25	Type 33	Type 51	3	10
" " ... ..	—	—	—	Type 21	Type 28	Type 45	3	10
" " ... ..	—	—	—	Type 17	—	Type 39	2	10
Holding Bolt Washer ... ..	4/053	4/053	4/053	4/053	4/053	4/053		2
Needle Jet ... ..	4/061	4/061	4/061	—	—	—	1	9
Needle for Jet ... ..	4/065	5/065	6/065	—	—	—	1	3
Air Adjusting Screw ... ..	13/129	13/129	13/129	—	—	—		6
Spring for Air Adjusting Screw	13/130	13/130	13/130	—	—	—		2
Filter ... ..	—	—	—	7/070	7/070	7/070	1	6
Jet Key ... ..	—	—	—	7/099	7/099	7/099	1	0
Main Jet ... ..	4/042	4/042	4/042	—	—	—		5
Main Jet ... ..	—	—	—	7/062	7/062	7/062	1	0
Pilot Jet ... ..	—	—	—	7/061	7/061	7/061	1	0



## FLOAT CHAMBER PARTS.

NAME OF PART.	PART NUMBERS				PRICE.	
	LARGE FLOAT CHAMBER.		SMALL FLOAT CHAMBER.			
	Bottom Feed.	Top Feed.	Bottom Feed.	Top Feed.	s.	d.
Float Chamber Body (Std. Base)	14/001	14/002	—	—	12	0
"    "    "    (Long Base)	14/003	14/004	—	—	12	0
"    "    "    (Double) ...	14/009	14/010	—	—	20	0
"    "    "    (Std. Base)	—	—	22/001	22/002	8	6
"    "    Cover ...	14/011	14/012	22/011	22/012	4	3
Float ...	14/015	14/017	22/016	22/016	2	6
Cover Lock Screw...	14/021	—	—	—	—	6
Needle ...	14/024	14/030	22/013	22/014	—	11
Petrol Union Nut ...	14/025	14/025	14/025	14/025	—	6
"    "    Nipple ...	14/026	14/026	14/026	14/026	—	3
Tickler ...	14/031	14/031	22/021	22/021	—	7
Tickler Spring ...	14/032	14/032	14/032	14/032	—	2
Cotter for Tickler ...	14/033	14/033	14/033	14/033	—	1

## LIST OF AMAL SERVICE STOCKISTS.

### GREAT BRITAIN.

<p>Spark &amp; Co. . . . . Premier Motor Co. . . . . C. T. Ashby, Ltd. . . . . Charles Sydney, Ltd. . . . . H. Bird &amp; Sons . . . . . Coventry Motor Mart . . . . . P. C. Stokes, Ltd. . . . . Leslie Paynter . . . . . E. Williams, Ltd. . . . . The Motor Cycle Mart . . . . . Alexander &amp; Co. . . . . I. Dias, Ltd. . . . . Grant &amp; Irving . . . . . Davies Bros. . . . . I. C. Pickering . . . . . E. J. Houlton . . . . . Hatton Motors . . . . . Alec Bennett . . . . . P. H. Jones &amp; Co. . . . . Phillips Bros. . . . . Kay Bros. . . . . J. W. Shaw &amp; Co. . . . . T. Garner &amp; Sons . . . . . Herbert Palin . . . . . Colmore Depot . . . . . Lindsay &amp; Sons . . . . .</p>	<p>SURREY—Oxted. BIRMINGHAM—Aston Road. KINGSTON-ON-THAMES—17, High St. BRADFORD—140, Manningham Lane. BIRMINGHAM—1,045, Coventry Road, Hay Mills. COVENTRY—London Road. NORTHAMPTON—1, Henry Street CHELTENHAM—Bath Street. WORCESTER—Lovesmoor. WALSALL—Stafford Street. EDINBURGH—113, Lothian Road. ABERDEEN—339, Union Street. CARLISLE—36, Warwick Road. DUMFRIES—Charlotte Street. CHESTER. SHREWSBURY—49, Mardol. NOTTINGHAM—166, Arkwright Street. DERBY—67, London Road. SOUTHAMPTON—The Broadway Gar- age, Portswood. WOLVERHAMPTON 28, Lichfield St. ALDERSHOT—Birchett Road. (Office, Garage, Spares &amp; Repairs Dept.) ALDERSHOT—Cranmore Lane (Works). BOLTON—119, High Bridge Street. BELFAST—37 and 39, Chichester Street. BARNSELEY—The Arcade, Eldon Street. DERBY—49/53, Osmaston Road. LIVERPOOL—Paradise Street. DUBLIN—22, Great Ship Street.</p>
--	--

### BELGIUM.

<p>Belgian Sidecars . . . . . Breslau . . . . . Dethier . . . . . Van Rymenant . . . . . Dessart . . . . . Briot . . . . . Tehrere . . . . . Van Ginderen . . . . . Renier . . . . . Desterbec . . . . . Tihange . . . . . De Stoop . . . . . Van de Calseyde et Bergsma . . . . . Druant . . . . . Tefnin . . . . . Konert . . . . . Baptiste Waltheré . . . . .</p>	<p>LIEGE—43, Rue Goswin. BRUSSELS—86, Rue Faider. BRUSSELS—121, Chaussée de Mons. BRUSSELS—2, Rue du Canal. NAMUR—10, Rue Monrabeau. NAMUR—22, Rue Dewez. ANVERS—33, Rue Van Beers. ANVERS—55, Rempart Ste. Catherine. CHARLEROI—23, Rue de Mons. MONS—28, Rue de Nimy. ARLON—103, Rue de Mersch. GAND—221, Coupure. GAND—38, Rue Haut Port. COURTRAI—7, Chaussée de Gand. SPA—42, Place Verte. LUXEMBOURG—Place de Paris. ELISABETHVILLE, CONGO BELGE— Avenue de l'Étoile.</p>
---	---

### DENMARK.

<p>Axel Ketner . . . . . Im. Stühr A/S . . . . . M. Mikkelsen . . . . . Soren Rasmussen . . . . . Sofus Nellemann . . . . .</p>	<p>KOBENHAVEN—Norrøvgade, 9. AALBORG—Danmarks-gade, 14-16. AARHUS—Vestergade, 6. ODENSE—Norrøvgade, 85. RANDERS—Storegade, 3.</p>
---	---

### DUTCH EAST INDIES.

<p>Lim Tjoei Keng . . . . .</p>	<p>BATAVIA, Java—Buiten Nieuwpoort</p>
---------------------------------	--



**FRANCE.**  
 R. Munro . . . . . PARIS—198, Boulevard Pereire.  
 Emile Knetch . . . . . ALGER, ALGERIE—18, Rue Richelieu.  
 Lafont & Tranche . . . . . RABAT, MAROC—Rue Pierre de Sorbier  
 J. B. Armand . . . . . NICE, A.M.—34, Rue de la Buffa.  
 Bittard . . . . . ORAN, ALGERIE—5, Rue Lamartine.  
 Albisua . . . . . BORDEAUX, GIRONDE—293, Rue  
 Thiers.  
 Roberty & Astier . . . . . MARSEILLES, B.R.—4, Rue d'Italie.  
 Gretier . . . . . SANGATTE, P. de C.  
 Bertelleto . . . . . CHAMBERY, SAVOIE—37, Route de  
 Lyon.  
 Froissard . . . . . LE MANS, SARTHE—45, Rue Gambetta.  
 Hommaire & Jouval . . . . . AVIGNON, VAUCLUSE—32, Boulevard  
 Sant Ruf.  
 Glassmann . . . . . MULHOUSE, HAUT RHIN—28, Rue de  
 Soultz.  
 Guillot . . . . . GRENOBLE, ISERE—27, Bd. Gambetta

**FINLAND.**  
 Aktiebolaget Stockmann . . . . . HELSINGFORS.

**HOLLAND.**  
 Burlage . . . . . THE HAGUE—113-115, De Carpentier-  
 straat.  
 Flinterman . . . . . THE HAGUE—5-7, Stationsplein.  
 Vlemmings . . . . . EINDHOVEN—23, Stratumschedyk.  
 H. L. Schellaars . . . . . ROTTERDAM—99, Graffbrisstraat.  
 Vlemmings . . . . . GELDROP—21, Nieuwendyk.  
 Croes & Co. . . . . BUSSUM—56, Nieuwe's Gravelandschweg  
 W. Kaptein . . . . . AMSTERDAM—Overtoom, 528-547.  
 W. Smit Hzn. . . . . AMSTERDAM—Spuistraat.

**CYPRUS.**  
 Simmons Bros. . . . . NICOSIA.

**MALTA.**  
 Mizzi Brothers . . . . . MARINA—10, 13, 14, 18, Molo Barriera.

**NORWAY.**  
 Gran-Henriksen & Co. . . . . OSLO, Motorspeed A/S—Toldbodgaten, 40

**SWITZERLAND.**  
 Edouard Gex . . . . . GENEVA—36, Coulonvreniere.  
 Jan . . . . . LAUSANNE—10, Rue des Terraux.  
 Arnold Grandjean . . . . . NEUCHATEL—Cycles & Motos Acces-  
 soires en Gros, 15, Avenue de en Garl.  
 Emil Frey . . . . . ZURICH—Stampfen-Bachplatz.  
 Emil Meier . . . . . WINTERTHUR—Metzgasse.  
 Ernst Raster . . . . . ST. GALLEN—47, Rorschacherstr.  
 Wassmer . . . . . ARRAN—Bahnhofstr.  
 Diriwachter . . . . . SCHAFFHAUSEN.  
 Enrico Riva . . . . . LUGANO.  
 A. Stadlin . . . . . LUCERNE—Pilatusplatz.  
 Charles Fricker . . . . . BALE—90, Guterstrasse.

**TURKEY.**  
 Comptoir de l'Acetylene . . . . . GALATA—Rue Hezarene N.12.

**BOTTOM FEED NEEDLES**

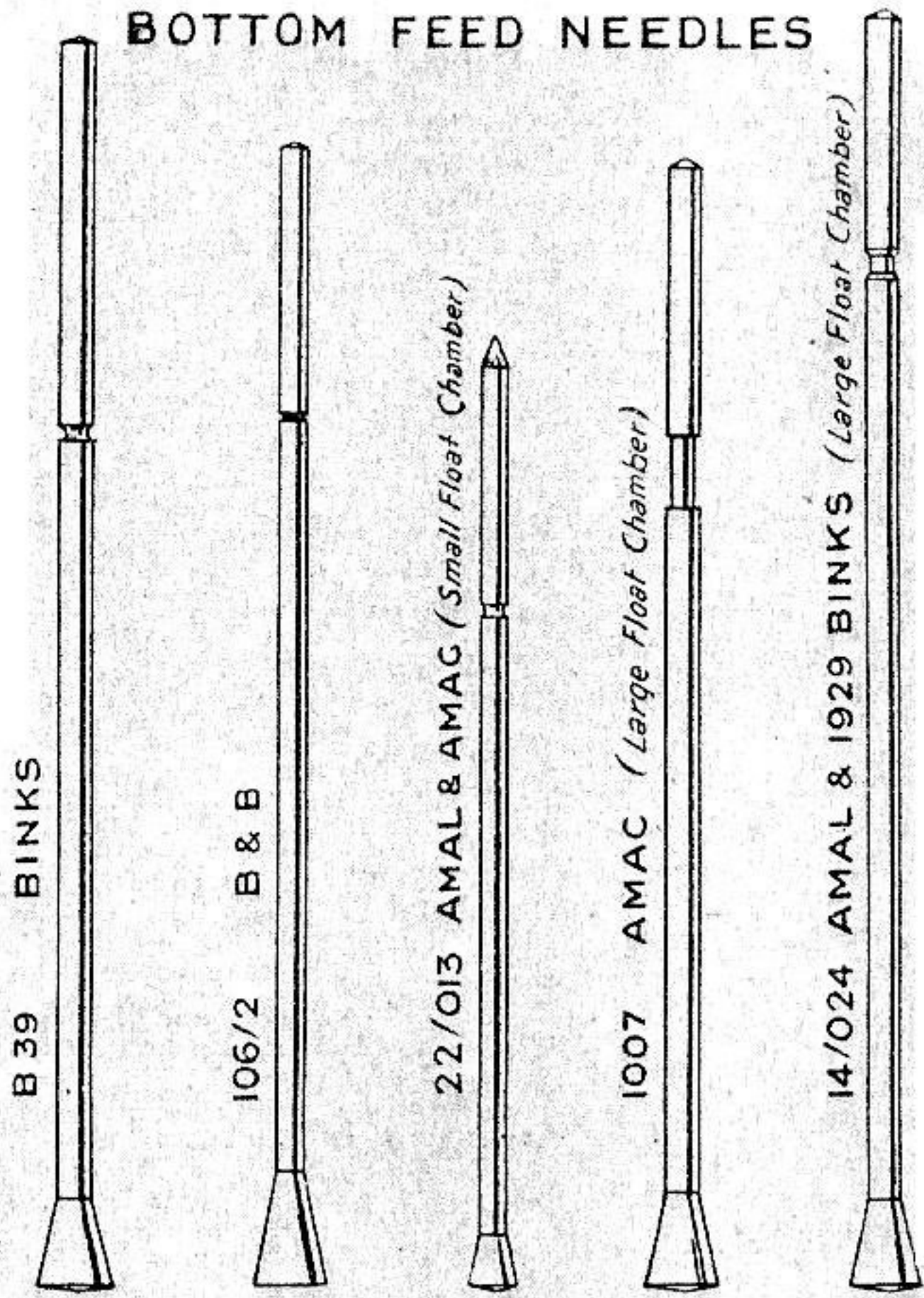

**TOP FEED NEEDLES**

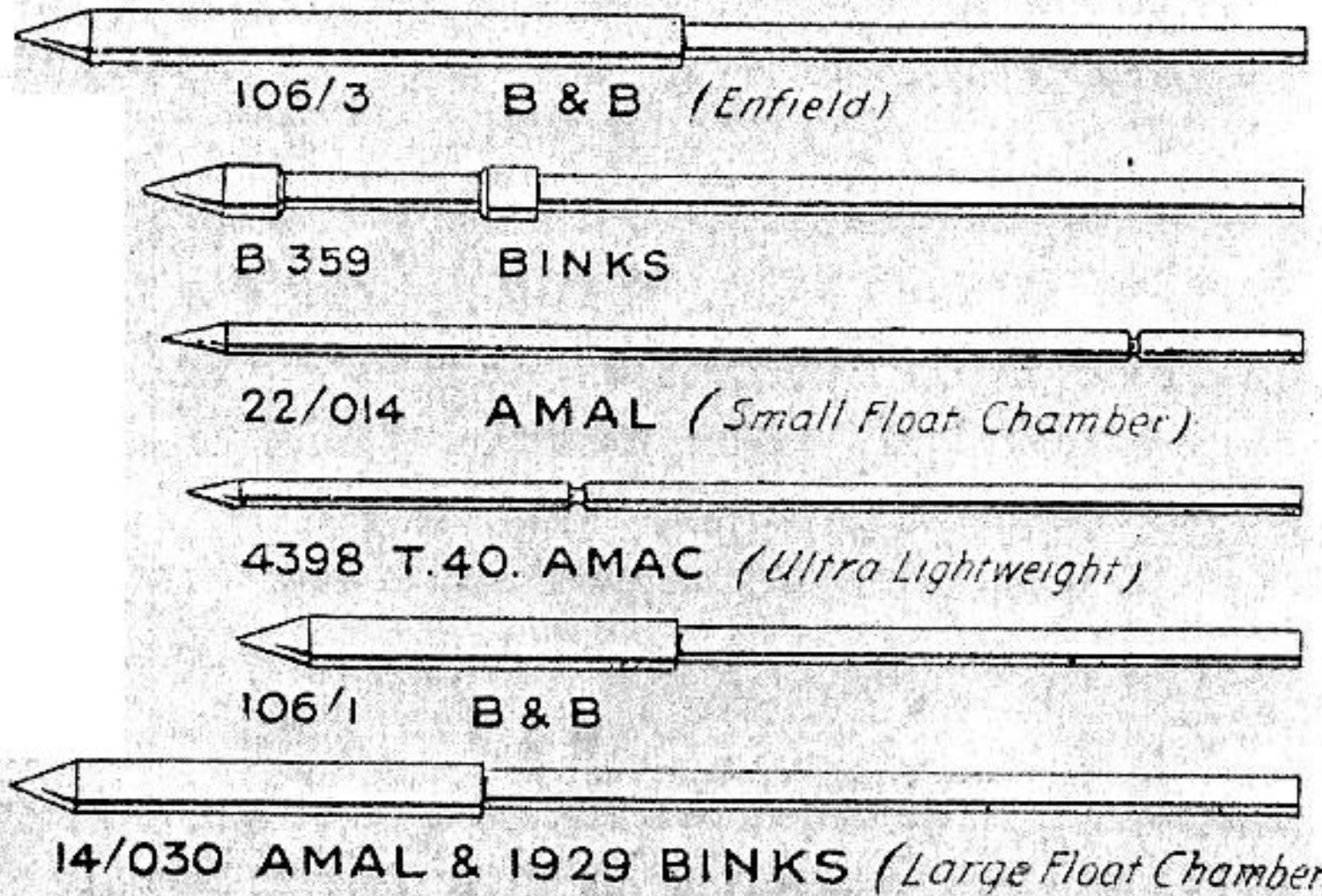

Various "Amal" Float Chamber Needles. Illustrations actual size.



*Printers :*

DREW & HOPWOOD, LTD.,  
BIRMINGHAM