

The Carburetter of Records & Successes

3

8

HOW IT WORKS AND PART NAMES

- | | |
|---------------------------------|---------------------------------|
| A. Mixing Chamber. | O. Needle Jet. |
| B. Throttle Valve (see page 6). | P. Main Jet (see page 6). |
| C. Jet Needle and Clip above. | Q. Float Chamber Holding Bolt. |
| D. Air Valve. | R. Float Chamber. |
| E. Mixing Chamber Union Nut. | S. Needle Valve Seating. |
| F. Jet Block. | T. Float. |
| G. Cable Adjuster (Throttle). | U. Float Needle Valve. |
| GI. Cable Adjuster (Air). | V. Float Needle Clip. |
| H. Jet Block Barrel. | W. Float Chamber Cover. |
| J. Pilot Orifice (see page 6). | X. Float Chamber Lock Screw. |
| K. Passage to Pilot. | Y. Tickler (to left of W.) |
| L. Pilot Air Passage. | Z. Mixing Chamber Top Cap. |
| M. Pilot Mixture Outlet. | ZI. Mixing Chamber Lock Ring. |
| N. Pilot By-pass. | ZII. Security Spring for above. |

The carburetter proportions and atomises the right amount of petrol with the air that is sucked in by the engine because of the correct proportions of jet sizes and the main choke bore. The float chamber maintains a constant level of fuel at the jets and cuts off the supply when the engine stops.

The throttle control from the handlebar controls the volume of mixture and therefore the power, and at all positions of the throttle the mixture is automatically correct. The opening of the throttle brings first into action the mixture supply from the pilot jet system for idling, then as it progressively opens, via the pilot by-pass, the mixture is augmented from the main jet, the earlier stages of which action is controlled by the needle in the needle jet. The main jet does not spray directly into the mixing chamber, but discharges through the needle jet into the primary air chamber, and goes from there as a rich petrol-air mixture through the primary air choke into the main air choke. This primary air choke has a compensating action.

The carburetters usually have a separately-operated mixture control called an air valve, for use when starting from cold, and until the engine is warm; this control partially blocks the passage of air through the main choke.

This design of carburetter offers perfectly simple and effective tuning facilities.

Fig. 3.

This section view does NOT apply if your carburetter has FOUR EXTERNAL primary air holes at the base of the mixing chamber. It is for carburetters with the primary air inlet in the main air intake.

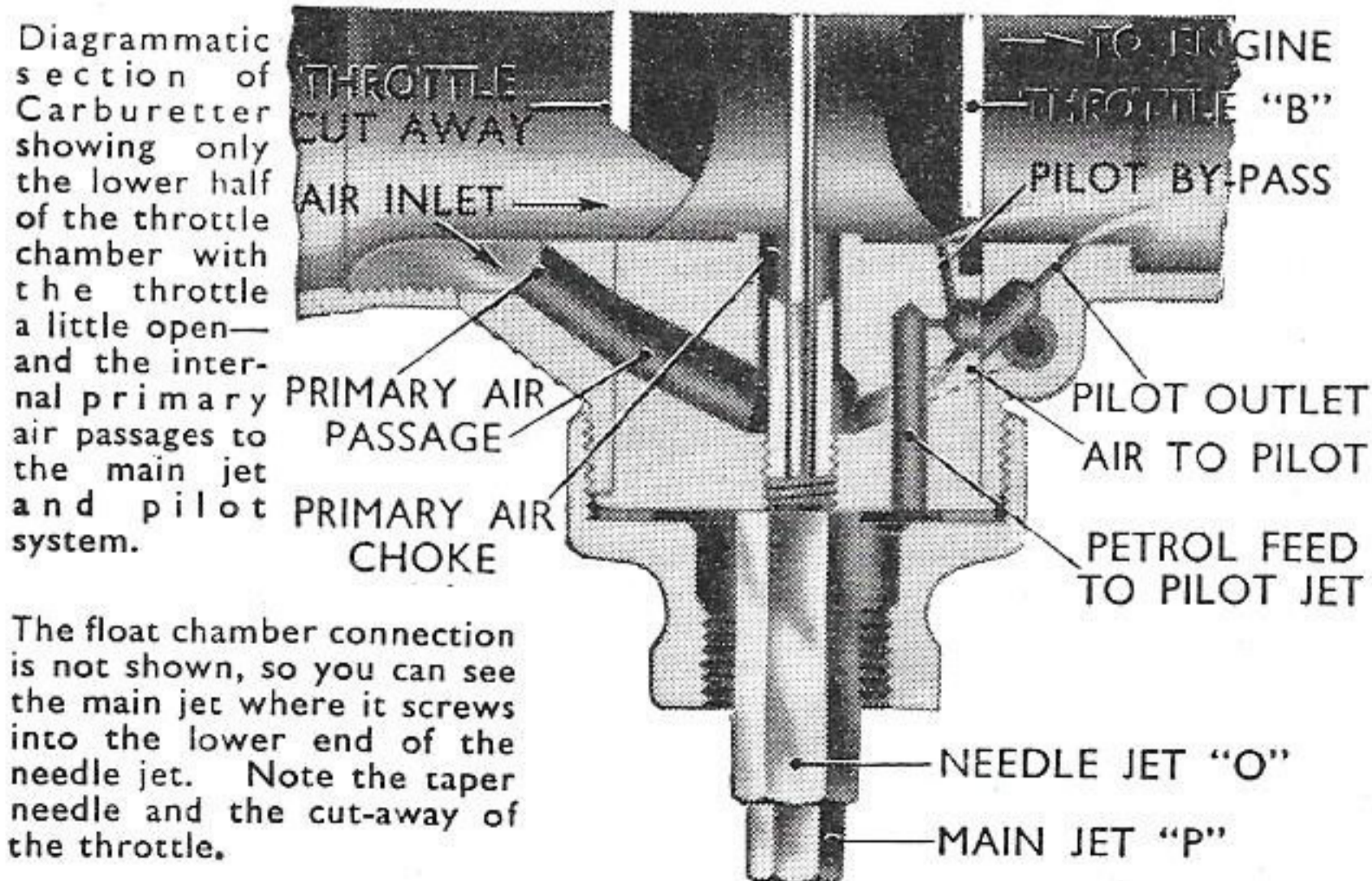

The float chamber connection is not shown, so you can see the main jet where it screws into the lower end of the needle jet. Note the taper needle and the cut-away of the throttle.

If the carburetter should flood whilst the engine is not running, the overflow from the main jet will run into the primary air passages and trickle out from there through a small hole seen at the side of the carburetter body.

TUNING TWIN ENGINES WITH TWIN CARBURETTERS

where each cylinder has its own Carburetter.

First of all, slacken the Throttle stop screws and put the Twist Grip into the shut off position to allow the Throttles to shut off; there should be a slight back lash in the cables which back lash can be obtained, if necessary, by screwing in the cable adjusting screws on the top of the Carburetter. Then, with the Handlebars in the normal position, and with the Throttles closed, adjust the cable adjusting screws so that on the slightest opening of the Twist Grip, both Throttles begin to open simultaneously.

To set the Carburetters, follow the procedure as given on page 7 overleaf, and bear in mind these "Hints," which may be useful:—Main Jet sizes are of course selected by checking the effect of the Mixture on the Sparking Plugs after taking a run at full throttle over a straight piece of road; the smallest pair of jets that give the best maximum speed is usually correct provided that the Plugs do not show any signs of excessive heat. It might be that for really critical tuning, one Carburetter might require a slightly different Jet size from the other.

For slow running, set the Twist Grip to make the Engine run slowly but just faster than a "tick over"; then gently screw in the Throttle stops to just hold the Throttles in that position, and return the Twist Grip into the shut position, leaving the Engine running on the Throttle Stops.

The next thing to do is to set each Carburetter according to paragraph 2, on Page 7, to obtain the idling by screwing down the Throttle Stop Screws and adjusting the Pilot Air Screws accordingly.

Regarding the setting of the Pilot Jets, a fairly satisfactory method is to detach one Sparking Plug lead, and set the Pilot Air Adjusting Screw on the other Cylinder as a single unit, and then reversing the process to the other Cylinder. It may be found that when both leads are connected to the Sparking Plugs, the Engine runs slightly quicker than desirable, in which case, a slight readjustment of the Throttle Stop Screws will put this right. It is essential that the speed of idling on both Cylinders is approximately the same, as this will either make or mar the smoothness of the get-away on the initial opening of the Throttle.

It is essential with Twin Carburetters that the Throttle Slides are a good fit in the bodies, and also that there is no suspicion of air leaks at either of the flange attachments to the Cylinder.

Regarding the lower end of the Throttle range, which is always the more difficult to set, one can only take excessive pains to make quite sure that the Control Cables are perfectly adjusted, without any excessive back lash or difference in the amount of back lash between one Carburetter and another; otherwise one Throttle slide will be out of phase with the other, and so resulting in lumpy running.

To check the opening of the Throttles simultaneously, shut the Twist Grip back so that the Throttles are resting on the Throttle Stop Screws in their final position of adjustment; then insert the fingers into the air intakes and press them on the Throttles and with the other hand, gently open by the Twist Grip and feel that the Throttles lift off their stops at the same time.

SERVICE ARRANGEMENTS

There are many AMAL Service Stockists in Great Britain and also in other countries where Motor-cycling is popular: They have information about recommended settings for all standard machines and, you are strongly advised to purchase GENUINE AMAL SPARES through them, at our List prices.

The Main Jets for these Carburetters have a general type No. 4/042 and have interchangeable threads. All GENUINE JETS are stamped with the name AMAL and with the Calibration Number. They are made with orifice sizes and numbered from 30 to 500, going up in increments of 5 c.c. from Nos. 30 to 100 and thence by 10 c.c.: for example, 100, 110, and 120, etc.

The "number" stamped on the Jet is the number of cubic centimetres of petrol that will pass through the orifice under conditions of test by the AMAL Jet Calibrating machine. Never reamer a Jet out.

All GENUINE AMAL JETS have been tested before marking, and all genuine AMAL SPARES, as sold by our Stockists, are produced under the same conditions of inspection as are the parts used in the production of Carburetters.

GUARANTEE.

The Company take all possible reasonable care in the manufacture and the quality of their products. Purchasers are informed that, any part proved to be defective in manufacture or quality, and returned to the works within six months of its purchase new, will be replaced.

The Company must respectfully point out however, that its responsibility and that of its agents, stockists and dealers, is limited to this Guarantee, and that they cannot, under any circumstances, be held responsible for any loss or for any contingent or resulting liability arising through any defect.

These conditions of sale and use also apply when the Company's products form part of the original equipment of machines purchased new.

HOW TO TUNE UP

PHASES OF AMAL NEEDLE JET CARBURETTER THROTTLE OPENINGS

Up to $\frac{1}{8}$ open	from $\frac{1}{8}$ to $\frac{1}{4}$ open	$\frac{1}{4}$ to $\frac{3}{4}$ open	$\frac{3}{4}$ to full open
PILOT JET	THROTTLE CUT-AWAY	NEEDLE-POSITION	MAIN JET SIZE

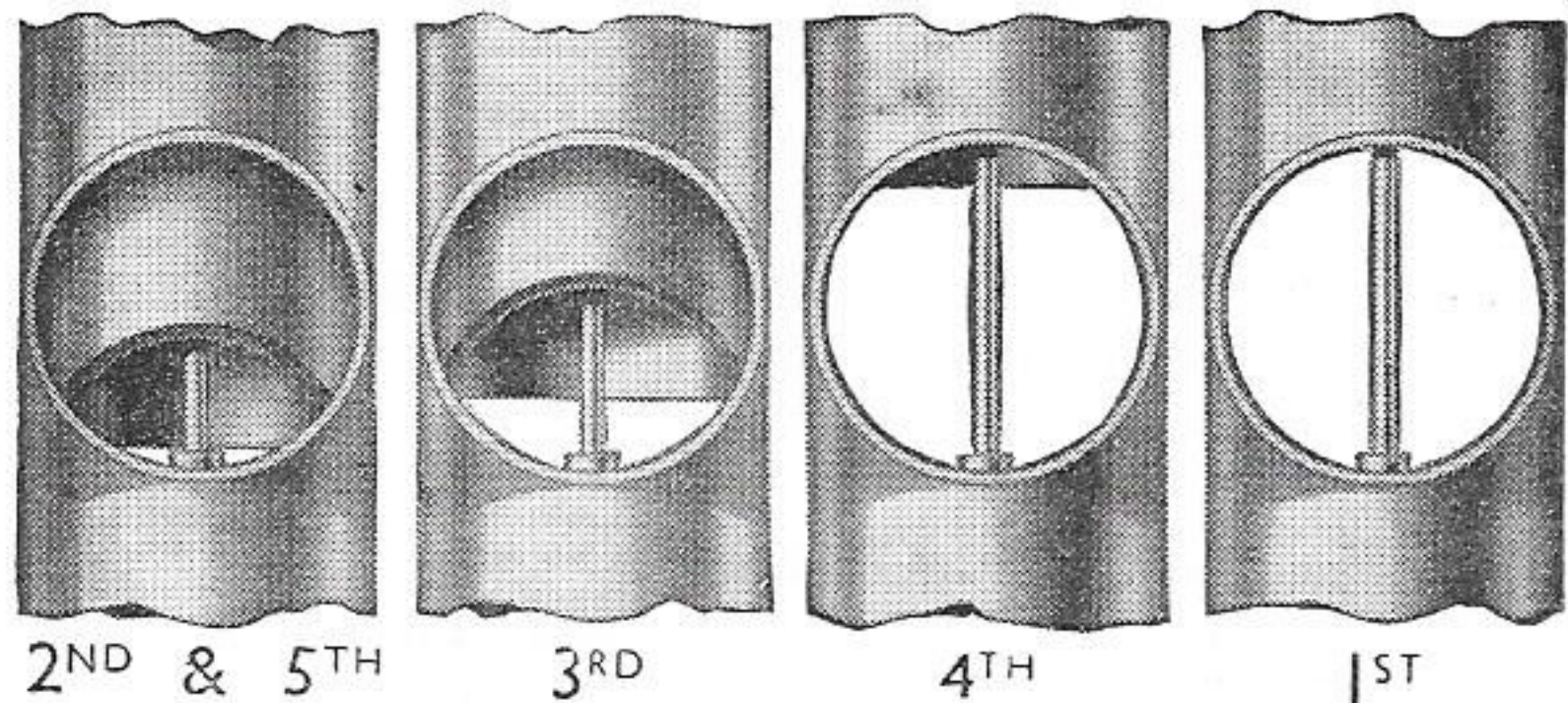

SEQUENCE OF TUNING

TUNE UP IN THE FOLLOWING ORDER ONLY, by so doing you will not upset good results obtained.

NOTE. The carburettor is automatic throughout the throttle range—the air valve should always be wide open except when used for starting or until the engine has warmed up. We assume normal petrols are used.

READ REMARKS ON PAGES 5 AND 6 for each tuning device and get the motor going perfectly on a quiet road with a slight up gradient so that on test the engine is pulling.

1st. MAIN JET with throttle in position 1 (§d, page 6).

If at full throttle the engine runs "heavily" the main jet is too large.

If at full throttle by slightly closing the throttle or air valve the engine seems to have better power, the main jet is too small.

With a correct sized main jet the engine at full throttle should run evenly and regularly with maximum power.

If testing for speed work ensure that the main jet size is sufficient for the mixture to be rich enough to keep the engine cool, and to verify this examine the sparking plug after taking a fast run, de-clutching and stopping the engine quickly. If the plug body at its end has a cool appearance the mixture is correct: if sooty, the mixture is rich: if, however, there are signs of intense heat, the mixture is too weak and a larger main jet is necessary.

2nd. PILOT JET WITH THROTTLE IN POSITIONS 2 AND 5.

With engine idling too fast with the twist grip shut off and the throttle shut down on to the throttle stop screw, and ignition set for best slow running: (1) Loosen stop screw nut and screw down until engine runs slower and begins to falter, then screw the pilot air screw in or out to make engine run regularly and faster. (2) Now gently lower the throttle stop screw until the engine runs slower and just begins to falter, then lock the nut lightly and begin again to adjust the pilot air screw to get best slow running; if this 2nd adjustment makes engine run too fast, go over the job again a third time. Finally, lock up tight the throttle stop screw nut without disturbing the screw's position.

3rd. THROTTLE CUT-AWAY with throttle in position 3 (§f, page 6).

If, as you take off from the idling position, there is objectionable spitting from the carburettor, slightly richen the pilot mixture by screwing in the air screw sufficiently, but if this is not effective, screw it back again, and fit a throttle with a smaller cut-away. If the engine jerks under load at this throttle position and there is no spitting, either the throttle needle is much too high or a larger throttle cut-away is required to cure richness.

4th. NEEDLE with throttle in position 4 (§e, page 6).

The needle controls a wide range of throttle opening and also the acceleration. Try the needle in as low a position as possible, viz., with the clip in a groove as near the top as possible; if acceleration is poor and with air valve partially closed the results are better, raise the needle by two grooves; if very much better try lowering needle by one groove and leave it where it is best.

Note, if mixture is still too rich with clip in groove No. 1 nearest the end—the Needle Jet probably wants replacement because of wear. If the needle itself has had several years' use, replace it also.

5th FINALLY go over the idling again for final touches.

SECTIONED ILLUSTRATION of NEEDLE JET CARBURETTER WITH PILOT JET SYSTEM

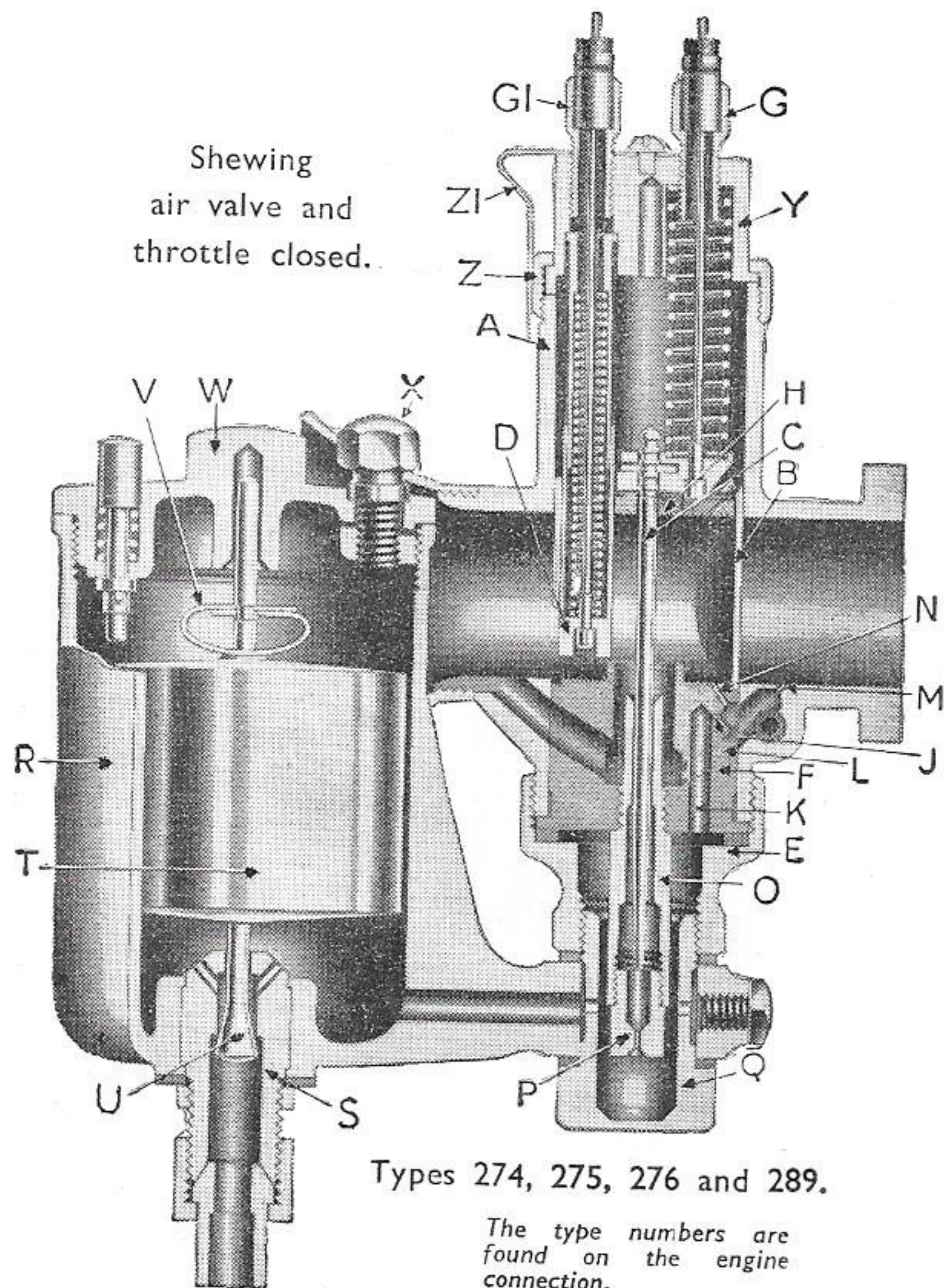

Types 274, 275, 276 and 289.

The type numbers are found on the engine connection.

Fig. 2.

Your carburettor may be vertical, inclined or horizontal, but diagrammatically this view applies to all models, the variation being in the attachment to the engine and of the floatchamber.

TWO DESIGNS.

Fig. 2 above is the sectioned view of the Standard Amal Carburettor as shown on page 1, figure 1.

This is the standard design where the primary air to the main jet and the pilot jet system comes in jointly through the main air intake, see figure 3, page 3. The type numbers are 274, 275, 276, 289.

An alternative design is made where the primary air to the main jet comes in through four visible ports around the base of the mixing chamber, and where also the air supply to the pilot jet system is separate. The type numbers of these carburettors are 74, 75, 76 and 89.

These tuning instructions apply to both the above designs.

The Carburetter of Records & Successes

4

6

HINTS AND TIPS

STARTING from cold. Flood the carburetter by depressing the tickler sharply three or four times, and close the air valve: set the ignition, say half retarded. Then shut the throttle and open it a little, viz., about one-eighth open, see diagram on page 7 position 2, then kick-start. If it is too much open starting will be difficult.

STARTING, engine hot. Do not flood the carburetter but close the air lever. Set the ignition and close the throttle, then open the throttle about one-eighth of its travel and kick-start. If the carburetter has been flooded and wont start because the mixture is too rich—open the throttle wide and give the engine several turns to clear the richness, then start again with the throttle one-eighth open, and air lever wide open. Generally speaking it is not advisable to flood at all when an engine is hot.

STARTING, general. By experiment, find out if and when it is necessary to flood, also note the best position for the air lever and the throttle for the easiest starting (some carburetters have the throttle stop fitted with a starting position on to which the throttle must be shut down).

STARTING, SINGLE LEVER CARBURETTERS. OPEN THE THROTTLE VERY SLIGHTLY FROM THE IDLING POSITION AND FLOOD THE CARBURETTER MORE OR LESS ACCORDING TO THE ENGINE BEING COLD OR HOT RESPECTIVELY.

CABLE CONTROLS. See that there is a minimum of backlash when the controls are set back and that any movement of the handlebar does not cause the throttle to open; this is done by the adjusters on the top of the carburetter. See that the throttle shuts down freely.

PETROL FEED, verification. Detach petrol pipe union at the float chamber end; turn on petrol tap momentarily and see that fuel gushes out. Avoid petrol pipes with vertical loops as they cause air locks. Flooding may be due to a worn or bent needle or a leaky float, but nearly all flooding with new machines is due to impurities (grit, fluff, etc.) in the tank—so clean out the float chamber periodically till the trouble ceases. If the trouble persists, the tank might be drained, swilled out, etc.

Note that if a carburetter, either vertical or horizontal, is flooding with the engine stopped, the overflow from the main jet will not run into the engine but out of the carburetter through a hole at the base of the mixing chamber.

FIXING CARBURETTER AND AIR LEAKS. Erratic slow running is often caused by air leaks, so verify there are none at the point of attachment to the cylinder or inlet pipe—check by means of an oil can and eliminate by new washers and the equal tightening up of the flange nuts. Also in old machines look out for air leaks caused by a worn throttle or worn inlet valve guides.

BANGING IN EXHAUST may be caused by too weak a pilot mixture when the throttle is closed or nearly closed—also it may be caused by too rich a pilot mixture and an air leak in the exhaust system; the reason in either case is that the mixture has not fired in the cylinder and has fired in the hot silencer. If the banging happens when the throttle is fairly wide open the trouble will be ignition—not carburation.

BAD PETROL CONSUMPTION of a new machine may be due to flooding, caused by impurities from the petrol tank lodging on the float needle seat and so prevent its valve from closing. If the machine has had several years use, flooding may be caused by a worn float needle valve. Also bad petrol consumption will be apparent if the throttle needle jet "O" (see fig. 2) has worn; it may be remedied or improved by lowering the needle in the throttle, but if it cannot be—then the only remedy is to get a new needle jet.

AIR FILTERS. These may affect the jet setting, so if one is fitted afterwards to the carburetter the main jet may have to be smaller. If a carburetter is set with an air filter and the engine is run without it, take care not to overheat the engine due to too weak a mixture; testing with the air valve (page 5, §4) will indicate if a larger main jet and higher needle position are required.

FAULTS, read page 5. The trouble may not be carburation; if the trouble cannot be remedied by making mixture richer or weaker with the air-valve, and you know the petrol feed is good and the carburetter is not flooding, the trouble is elsewhere.

RE-ASSEMBLING after dismantling. Note particularly that the mixing chamber nut E (fig. 2, page 2) is tightened up tight on to the washer that holds the jet block F (fig. 2, page 2), otherwise petrol will leak up. When replacing the throttle see that the throttle needle goes into the centre hole in the choke block and once in, note the throttle works freely when the mixing chamber top ring Z is screwed down firmly and held by spring Z1.

Float chamber lid. To remove, first loosen screw X (fig. 2). To remove float, pinch the bow V (fig. 2), and pull; when replacing, slip over needle and slide down till bow jumps into the needle groove. Care required to avoid bending needle.

PARTS TO TUNE UP WITH

(a) This fig. 4 is two diagrammatic sections of the carburetter to show:—

1. The throttle stop screw.
2. The pilot air screw.

(b) **THROTTLE STOP SCREW.** Set this screw to prop the throttle open sufficiently to keep the engine running when the twist grip is shut off.

(c) **PILOT AIR SCREW.** This screw regulates the strength of the mixture for "idling" and for the initial opening of the throttle. The screw controls the suction on the pilot petrol jet by metering the amount of air that mixes with the petrol.

NOTE.—The air for the pilot jet may be admitted internally or externally according to one or other of the designs, but there is no difference in tuning.

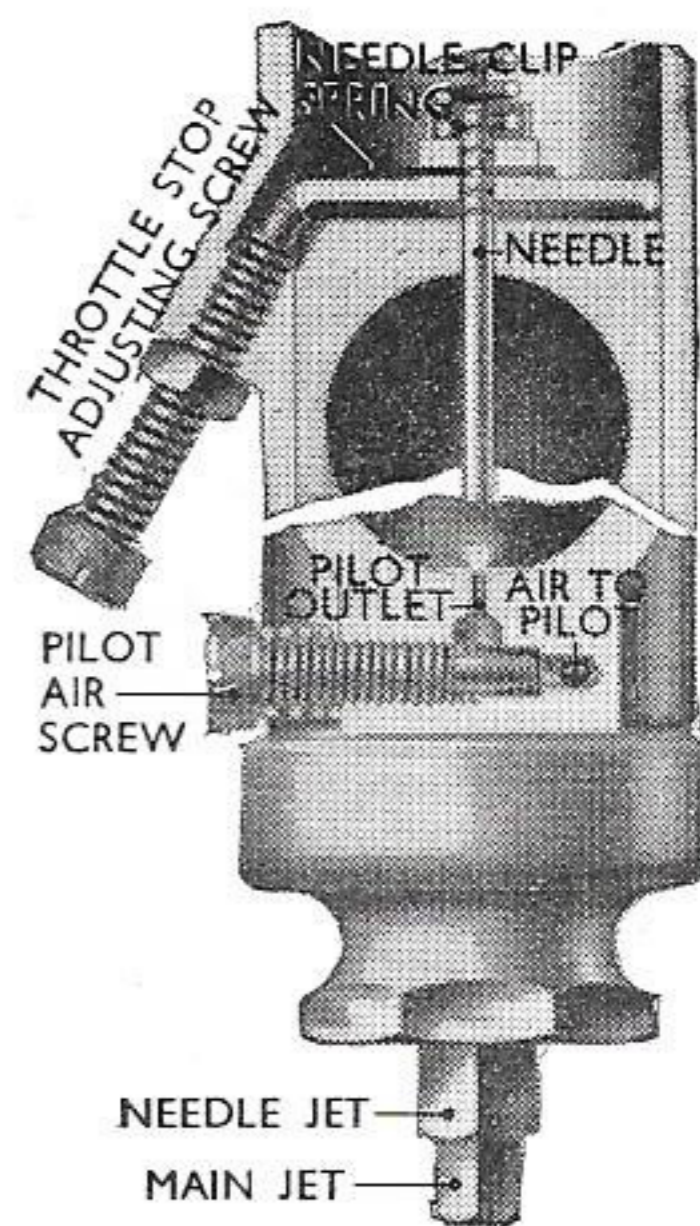
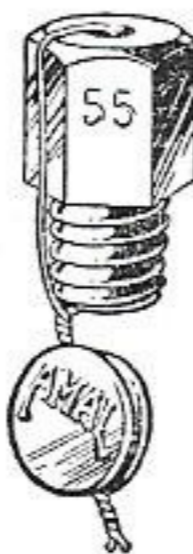

Fig. 4.

(d) **MAIN JET.** The main jet controls the petrol supply when the throttle is more than three-quarters open, but at smaller throttle openings although the supply of fuel goes through the main jet, the amount is diminished by the metering effect of the needle in the needle jet.

Each jet is calibrated and numbered so that its exact discharge is known and two jets of the same number are alike. NEVER REAMER A JET OUT, GET ANOTHER OF THE RIGHT SIZE. The bigger the number the bigger the jet. Spare jets ARE SEALED.

To get at the main jet, undo the float chamber holding bolt Q (page 2). The jet is screwed into the needle jet so if the jet were tight, hold the needle jet also carefully with a spanner, whilst unscrewing the main jet.



(e) **NEEDLE AND NEEDLE JET.** The needle is attached to the throttle and being taper—either allows more or less petrol to pass through the needle jet as the throttle is opened or closed throughout the range, except when idling or nearly full throttle. The needle jet is of a defined size and is only altered from standard when using alcohol fuels.

The taper needle position in relation to the throttle opening can be set according to the mixture required by fixing it to the throttle with the needle clip spring in a certain groove (see illustration above), thus either raising or lowering it. Raising the needle richens the mixture and lowering it weakens the mixture at throttle openings from quarter to three-quarters open (see illustration, page 7).

(f) **THROTTLE VALVE CUT-AWAY.** The atmospheric side of the throttle is cut away to influence the depression on the main fuel supply and thus gives a means of tuning between the pilot and needle jet range of throttle opening. The amount of cut-away is recorded by a number marked on the throttle, viz., 6/3 means throttle type 6 with No. 3 cut-away; larger cut-aways, say 4 and 5, give weaker mixtures and 2 and 1 richer mixtures.

(g) **AIR VALVE** is used only for starting and running when cold, and for experimenting with, otherwise run with it wide open.

(h) **TICKLER,** a small plunger spring loaded in the float chamber lid. When pressed down on the float, the needle valve is pushed off its seat and so "flooding" is achieved. Flooding temporarily enriches the mixture until the level of the petrol subsides to normal.