



July, 1956.

LIST No. 469 (Issue No. 2).

## The Carburetter of Records & Successes

### INSTRUCTIONS FOR

# TYPES 15 G.P., 10 G.P., 5 G.P., 3 G.P.

## CARBURETTERS (Series 316)

With fixed or remotely-mounted  
type 302 top-feed Float Chamber and  
SUITABLE FOR USE WITH ALL  
GRADES OF RACING FUELS.

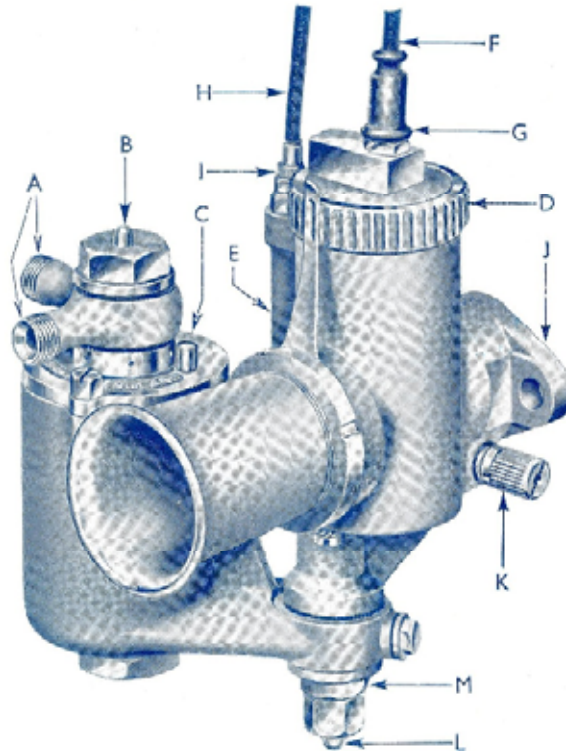

#### KEY TO ILLUSTRATION

- A. Banjo (Twin), 90°, horizontal petrol pipe connections.
- B. Banjo Nut with hole for lock wire.
- C. Tickler.
- D. Mixing Chamber Cap. A screwed ring.
- E. Lock Spring for Mixing Chamber cap.
- F. Throttle Cable.
- G. Throttle Cable Adjuster with lock nut.
- H. Air Cable for mixture control.
- I. Air Cable Adjuster with lock nut.
- J. Flange Attachment to Engine.
- K. Pilot Needle, adjustment for slow running.
- L. Jet Holder Plug Screw, remove to get at main jet.
- M. Jet Holder, also holds float chamber to mixing chamber body.

#### TECHNICAL INFORMATION.

TYPE	CHOKE BORES MEASURED BEHIND THROTTLE VALVES	THROTTLE DIAMETER	FLANGE BOLT-HOLE CENTRES	MIXING CHAMBER TO FACE OF FLANGE
15 G.P.	$\frac{7}{8}$ ", $\frac{3}{8}$ ", 1", $1\frac{1}{16}$ "*	$\frac{11}{16}$ "	} or 2" 65 m.m.	} $1\frac{3}{4}$ " or $2\frac{1}{4}$ "
10 G.P.	$1\frac{1}{16}$ ", $1\frac{3}{32}$ ", $1\frac{1}{8}$ ", $1\frac{5}{32}$ ", $1\frac{3}{16}$ ", $1\frac{7}{32}$ "*	$\frac{13}{16}$ "		
5 G.P.	$1\frac{1}{8}$ ", $1\frac{1}{4}$ ", $1\frac{3}{8}$ ", $1\frac{5}{8}$ ", $1\frac{11}{16}$ ", $1\frac{3}{4}$ "*	$1\frac{3}{16}$ "	} 65 m.m.	} 2"
3 G.P.	$1\frac{1}{4}$ ", $1\frac{11}{16}$ ", $1\frac{1}{2}$ ", $1\frac{13}{16}$ "*	$1\frac{1}{8}$ "		

\*Straight-through Bore with no swell.—see note page 3.

#### TUNING SPARES.

TYPE	THROTTLE VALVES	THROTTLE NEEDLES	MAIN JETS	NEEDLE JETS	AIR JETS
15 G.P.	15 G.P. Cutaway 3 to 8 Part No. 316/104	Standard G.P. Part No. 316/007	} Inter-changeable Type T.T. Part No. 3326	} Inter-changeable Type G.P. Part No. 316/065	} Inter-changeable Type G.P. ·10" or ·125" Part No. 316/052
10 G.P.	10 G.P. Cutaway 3 to 8 Part No. 316/010	G.P. Part No. 316/007			
5 G.P.	5 G.P. Cutaway 3 to 8 Part No. 316/020	5 G.P. Part No. 316/146			
3 G.P.	3 G.P. Cutaway 3 to 8 Part No. 316/413	3 G.P. Part No. 316/465			
		Weak G.P.6 316/030			
		G.P.6 316/030			
		5 G.P.6 316/029			
		3 G.P.6 316/468			

**AMAL LTD., HOLDFORD ROAD, WITTON,  
BIRMINGHAM 6, ENGLAND**

'Phone : Birmingham, BIRchfields 4571.  
(P.B.X. 6 lines)

Telegrams : "AMALCARB, 'PHONE,  
BIRMINGHAM."

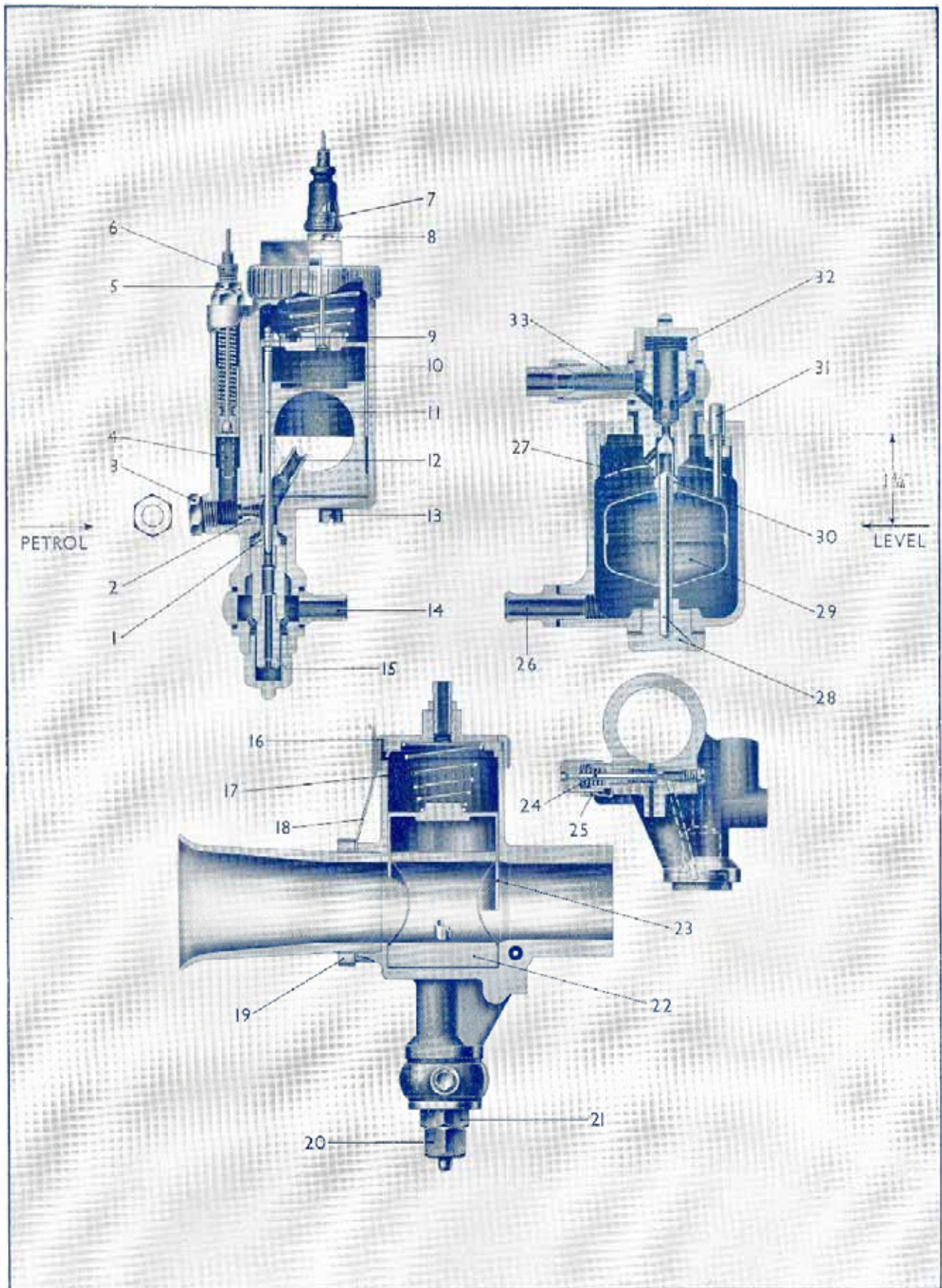

## GENERAL OPERATION.

### DESIGN FEATURES.

The G.P. Carburetter has been designed with a view to obtaining the maximum possible power from the engine, at the same time maintaining a progressive and consistent acceleration characteristic throughout the throttle range.

As a result, this Carburetter gives maximum power equivalent to that previously associated with the remote needle type of Carburetter, with consistency over the throttle range equivalent to that previously obtained with the T.T. type of instrument.

The main gain has been effected by embracing the metering needle (11) within the confines of the throttle valve itself (23), which, although leaving an unrestricted bore at full throttle, also leaves a very short tract for the mixture to traverse from the needle jet (1) to the choke.

Resulting from these two points of design, it will be found that in conjunction with the maximum power obtainable, a much smoother throttle control is possible at the lower r.p.m. which has the result where megaphone exhausts are used, of allowing a cleaner entry on to the megaphone than was previously possible. Also the point at which the megaphone's effect occurs is appreciably lower which, of course, is an obvious advantage on the road.

### CHOKE BORE DIAMETERS.

Except in the maximum **CHOKE SIZES** of the three types of G.P. Instruments, it will be found that the effective choke diameter of the Mixing Chamber is on the engine side of the throttle slide (23), between it and the outlet of the Carburetter, and not in the centre of the choke adaptor (22) as might be expected. The reason for this is that exactly as the needle in the T.T. type of instrument caused obstruction across the choke, so, but to a much lesser degree, does the fuel emission from the G.P. spray tube (12). We, therefore, slightly swell the choke at this point which overcomes this fuel obstruction and then, by means of a taper, the choke diameter returns to its stipulated dimension before reaching the outlet of the Carburetter. Therefore, in referring to the choke size of a G.P. Carburetter, it is this smallest diameter in the Mixing Chamber which is of moment.

Naturally, when deciding on the choke size of a Racing Carburetter, the peak r.p.m. of the engine is the main controlling factor in conjunction, of course, with the inlet port diameter on the engine in question. Therefore, when ordering one of these instruments from us it is always safer, apart from mentioning the engine, to also give us the maximum r.p.m. and the inlet port diameter, when we shall then be able to assess exactly the correct choke size of the instrument.

### FITTING.

Regarding fitting the Carburetter, although we are often asked what is the correct distance between the inlet valve centre line and the centre of the Carburetter Mixing Chamber, this is not a figure which can be laid down in hard and fast manner, as it varies enormously from one engine to another, although maximum efficiency is obtained in both cases. Broadly speaking, a distance of between 7" to 9" probably represents a fair mean dimension.

Flange fitting is standardised with the G.P. Carburetter to eliminate as much as possible the worrying source of air leaks which often persists with clip fitting instruments.

G.P. Carburetters are available for vertical and downdraught fittings, the maximum downdraught which we recommend being 20° as with anything in excess of this trouble is likely to be encountered because of the pilot fuel feed.

### FLOAT CHAMBERS.

The Float Chamber fitted to the current model G.P. Carburetters is known as our type 302, and incorporates a top feed seating in conjunction with a large headed needle (30) ensuring a more than ample flow of fuel to the Mixing Chamber. This large top feed float chamber is capable of passing 10 gallons per hour of fuel at an 18" head. Consequently, it has done away with the necessity for double float chambers as were previously used, except in special cases such as dirt track racing and sidecar use.

Wherever possible the Float Chamber should be remotely mounted, from the point of view of flooding due to vibration but, of course, where this is not possible we do supply rigid float chambers which are attached to the mixing chamber in the orthodox manner. These are either upright or cranked at the angle of the induction port of the engine in question, so that it is, therefore, necessary when ordering a Carburetter incorporating a solidly mounted float chamber to state the angle of the induction port.

### PETROL LEVEL.

The petrol level in the Type 302 Float Chamber is  $1\frac{5}{16}$ " below the cover joint face (see diagram, page 2). Where the float chamber is remotely mounted, it should be so positioned that this level lines up with the lowest point of the circular scribe-mark on the Air Jet Plug (3).

### LOCKING DEVICES.

A spring blade locking device (18) held in place by the air tube lock ring (19) engages with serrations on the mixing chamber cap (16), which positively prevents the unscrewing of same due to vibration.

With regard to the jet base nut (20), banjo nut (32) and jet block holding screws (13,) these are fitted with drilled heads to enable same to be wired up in the orthodox manner.

**TUNING.—GENERAL.**

The tuning sequence of the G.P. Carburetter follows the well established Amal principles, inasmuch as there is a main jet (15) controlling the fuel supply at full throttle, a needle jet (1) the emission from which is controlled by the position of the taper needle (11) in same and at the lower throttle openings by the cut-away of the throttle valve (23) in question, an independently adjustable pilot fuel needle (24) controlling the mixture strength for idling. There is a new adjustment in the form of an air jet (2) which controls the amount of air which primarily atomises the fuel as it comes out of the needle jet (1) before going into the spray tube (12) and thence to the heart of the choke. This latter air jet (2) is a form of depression control for the main jet, and from normal experiences would appear to require a  $\cdot 1"$  diameter air jet for choke sizes of up to  $1\frac{1}{16}"$  and  $\cdot 125"$  diameter for choke sizes in excess of this figure. Normally speaking, this air jet would be fitted by the Factory when the Carburetter was supplied, and would not be considered a likely component to change, but remembering that the main jet depression can be increased by fitting a smaller air jet, it may sometimes, for special purpose tuning, be found an asset to try a larger or smaller air jet according to which one is already fitted.

The **NEEDLE** control covers a range of the throttle opening from about one-third throttle up to seven-eighths throttle opening. The needle grooves in the G.P. needle will be found to number five instead of seven as previously on the T.T. instruments, due to the fact that the needle control of the G.P. Carburetter is rather more sensitive than on other types. Two types of needle (11) are available, what we call a standard taper needle and a much weaker taper needle. The needles in both Type 15 and Type 10 G.P. instruments are the same length. Consequently, the standard taper needle in these two instruments is known as the G.P. Needle: the weaker taper needle in these two types of instruments is known as the G.P. 6 Needle.

With regard to the larger Types 5 G.P. and 3 G.P. Instruments, their needles are longer than the ones in the two smaller types, and the standard tapers are known as Type 5 G.P. and Type 3 G.P. Needles: the weaker taper needle is designated the Type 5 G.P.6. and Type 3 G.P.6.

Where megaphone exhausts are concerned, it will be found invariably advisable to use the weaker types of needle, and generally these can also be run at a fairly low position, namely, —needle position 1 or 2—that is, the first or second groove from the top of the needle.

It will then be found that the stability on the megaphone is much improved and any tendency towards weakness at the bottom of the throttle opening can, of course, be rectified by fitting a fairly low numbered throttle valve.

**MAIN JET.**

Always bear in mind, however, that whatever the type of needle used, or the position in which it is fitted, there will be no affectation of the main jet (15). This should be arrived at by fitting the jet which gives the best possible power on the bench or, on the other hand, the highest possible R.P.M. on the road, and once this has been obtained, under no circumstances should it be altered.

The main jet (15) can be very readily removed by taking off the hexagon cap (20) at the base of the Carburetter Mixing Chamber. The jet size is marked on the side of these jets, and represents the flow in c.c. per minute on our Amal Calibrating Machines at the Works. These jets are made in 10 c.c. increments, that is, for instance—250, 260, 270, etc.—up to and including 600, when, after this, 20 c.c. increments become standard.

It should be noted that on the G.P. range of Carburetters smaller main jets than usual are fitted. This is due to the fact that a higher depression main jet system is employed. For rough guidance, therefore, the following jet sizes should be approximately correct for the choke sizes in question:—

Using 80 Octane or Petrol Benzol Fuel.

15 G.P.,  $\frac{3}{8}"$  choke—Jet 180. | 10 G.P.,  $1\frac{1}{16}"$  choke—Jet 210. | 5 G.P.,  $1\frac{1}{4}"$  choke—Jet 270. | 3 G.P.,  $1\frac{1}{16}"$  choke—Jet 330  
15 G.P.,  $1"$  choke—Jet 200. | 10 G.P.,  $1\frac{1}{8}"$  choke—Jet 260. | 5 G.P.,  $1\frac{3}{8}"$  choke—Jet 310. | 3 G.P.,  $1\frac{1}{4}"$  choke—Jet 350

with, of course, the intermediary choke sizes, using a proportionate sized jet. The rest of the throttle range should then be dealt with absolutely individually in steps by means of the needle adjustment throttle valve cut-away alteration and pilot adjustment, with a possible check on the air jet fitted.

The **THROTTLE VALVE** (23), of course, which surrounds the choke adaptor (22) in the Carburetter, controls with its leading edge the amount of air entering the throttle bore at the lower throttle openings, at least that is up to the point where the cut-away starts to disappear up the Mixing Chamber bore, which, naturally, varies slightly with each number of throttle valve that is fitted.

The trailing edge of the throttle valve, of course, controls the volume of mixture passing to the engine.

These throttle valves can be supplied with various cut-aways from No. 3 up to No. 8, each number varying in its cut-away on the air intake side by  $\frac{1}{16}"$ .

The **NEEDLE JET** (1), which is of stainless steel to prevent wear, has been found for best all round usage on petrol or petrol benzole to require a diameter of  $\cdot 107"$  for choke sizes up to  $1\frac{1}{32}"$ , over this a needle jet of  $\cdot 109"$  diameter is necessary. For alcohol fuel, of course, larger needle jets are necessary: this is dealt with on page 6.

The **PILOT JET** on this Instrument is a taper needle (24) which controls the volume of fuel passing to the pilot assembly where it mixes with air from a permanent leak hole in the body, ultimately passing into the Mixing Chamber itself through a small hole at the back of the throttle slide. It mixes with air coming under the throttle valve through the main bore at this point and then passes into the engine as the necessary slow running mixture.

This method of fuel adjustment has a very wide effect on the lower end carburation, and it will be found possible to control to quite a large degree the initial pick-up by an accurate setting of this pilot screw. A word of warning should be given that it is a bad thing to set this as weak as possible which, with a warm engine, may result in a very good tick-over being obtained but it will be found that there is a tendency for a flat spot to persist when opening the throttle. In consequence of a really good tick-over not being of great moment where racing carburation is concerned, a slightly rich setting of the pilot screw is desirable, which will help towards obtaining a more perfect opening up.

**COMPENSATION** on this G.P. Carburetter is obtained through the medium of the primary air which passes through a slot (4) in the Mixing Chamber and then, via the air jet (2) previously mentioned, atomises the liquid fuel passing from the needle jet (1).

As the engine supply increases or decreases at a given throttle opening with a varying load, so compensation will take place. The mixture strength supplied to the engine will vary as the air supply falls off, or increases according to whether the R.P.M. decreases or increases, due to the lesser density of the air compared to the petrol. This damping effect on the flow of liquid results in a compensated mixture being maintained.

## KEY TO SECTIONED ILLUSTRATION.

### MIXING CHAMBER.

- 1.—Needle Jet.
- 2.—Air Jet.
- 3.—Air Jet Plug.
- 4.—Primary Air Slot.
- 5.—Air Valve Cable Adjuster Locknut.
- 6.—Air Valve Cable Adjuster.
- 7.—Throttle Cable Adjuster.
- 8.—Throttle Cable Adjuster Locknut.
- 9.—Needle Clip.
- 10.—Needle Clip Retaining Screw.
- 11.—Metering Needle.
- 12.—Spray Tube.
- 13.—Choke Adaptor Retaining Screws.
- 14.—Petrol Inlet Banjo.
- 15.—Main Jet.
- 16.—Mixing Chamber Cap.
- 17.—Throttle Valve Return Spring.
- 18.—Mixing Chamber Cap Lock-Spring.

- 19.—Air Tube Lock Ring.
- 20.—Jet Plug.
- 21.—Jet Holder.
- 22.—Choke Adaptor.
- 23.—Throttle Valve.
- 24.—Pilot Jet adjusting Needle.
- 25.—Pilot Adjuster Lock-Spring.

### FLOAT CHAMBER.

- 26.—Petrol Outlet Connection.
- 27.—Baffle Plate.
- 28.—Base Plug and Float Guide Peg.
- 29.—Float.
- 30.—Float Needle.
- 31.—Tickler.
- 32.—Banjo Nut.
- 33.—Petrol Inlet Banjo.

## TUNING SEQUENCE.

To get carburation for any stated fuel when the choke bore is correct for the peak revs. of the engine and the correct needle jet for the fuel to be used, the procedure is simple. Start off with an assumed setting, and then tune as follows. There are four phases:

- (1)—Main jet for power at full throttle;
- (2)—Pilot jet for idling;
- (3)—Throttle cut-away for "take off" from the pilot jet;
- (4)—Needle position for snappy mixture at quarter to three-quarter throttle; then final idling adjustment of the pilot jet.

Always tune in this order, then any alteration will not upset a correct phase.

**SEQUENCE OF TUNING.** (1)—Main jet size. (2)—Pilot jet adjustment. (3)—Throttle valve cut-away. (4)—Needle attachment.

**1.—MAIN JET SIZE.** This should be determined first: the smallest jet which gives the greatest maximum speed should be selected, keeping in mind the safety factor for cooling. (*The air lever should be fully open during these tests.*)

**2.—PILOT JET ADJUSTMENT.** Before attempting to set the pilot adjuster the engine should be at its normal running temperature, otherwise a faulty adjustment is possible, which will upset the correct selection of the throttle valve. The pilot adjuster, which controls the amount of fuel passed, is rotated clockwise to weaken the mixture, and anti-clockwise to enrich it. Adjust this very gradually until a satisfactory tick-over is obtained, but take care that the achievement of too slow a tick-over—that is, slower than is actually necessary—does not lead to a "spot" which may cause stalling when the throttle is very slightly open.

**3.—THROTTLE CUT-AWAY.** Having set the pilot adjuster, open up the *throttle* progressively and note positions where, if at all, the exhaust note becomes irregular. If this is noticed, leave the throttle open at this position and close the air lever slightly; this will indicate whether the spot is rich or weak. If it is a rich spot, fit a throttle valve with more *cut-away* on the air intake side (or *vice versa* if weak).

**4.—JET NEEDLE POSITION.** Tuning sequence 2 and 3 will affect carburation up to somewhere over one-quarter throttle, after which the jet *needle*, which is suspended from the throttle valve, comes into action and when the throttle is opened further and tests are again made for rich or weak spots, as previously outlined, the needle can be raised to enrich or lowered to weaken the mixture, whichever may be found necessary. With these adjustments correctly made, and the main jet size settled, a perfectly progressive mixture will be obtainable from tick-over to full throttle. The jet *needles* are interchangeable in carburetters type 15 G.P. or 10 G.P., but longer needles are required for the Type 5 G.P. and Type 3 G.P.



## ALCOHOL FUELS.

Concerning Alcohol fuels, the G.P. range of Carburettors function perfectly satisfactorily on any alcohol blend up to and including straight methanol. It will be necessary to fit a .125" diameter needle jet (1) for any alcohol content over 50%. With this larger needle jet a standard taper needle (11) should be used, which means for the Type 15 G.P. a needle marked G.P. is required, for the Type 10 G.P. a needle marked G.P. is required (both these types using the same needle); for the Type 5 G.P. a needle marked 5 G.P. is needed, and for a type 3 G.P. a needle marked 3 G.P. is needed. An approximately correct needle position will be No. 4, that is:— the fourth groove from the top of the needle.

Regarding main jet sizes, these have to be increased in the following proportions, taking the basic size as that used for 80 octane fuel or petrol benzol.

Straight Methanol	..	..	..	Increase the basic jet size by 150%.
J.A.P. Racing Fuel	..	..	..	Increase the basic jet size by 150%.
Esso No. 1 Fuel	..	..	..	Increase the basic jet size by 150%.
Esso No. 2 Fuel	..	..	..	Increase the basic jet size by 120%.
Esso No. 3 Fuel	..	..	..	Increase the basic jet size by 130%.
Shell A.M.M. Fuel	..	..	..	Increase the basic jet size by 150%.
Shell A.M.1 Fuel	..	..	..	Increase the basic jet size by 140%.
Shell A.M.8 Fuel	..	..	..	Increase the basic jet size by 120%.
Shell A.M.9 Fuel	..	..	..	Increase the basic jet size by 100%.
Shell A.M.12 Fuel	..	..	..	Increase the basic jet size by 50%.

NOTE.—When calculating the jet size on the basis of the jet size used for petrol-benzol mixtures—the per cent. increase must be added to the original jet size and the total is the new size of jet to be used for the particular fuel. EXAMPLE: If a Jet No. 300 was used for petrol-benzol and it was decided to change over to METHANOL, which requires an increase of 150% adding to the original jet size 300.

Calculate this way:— $\left(\frac{\% \text{ increase} \times \text{original jet size}}{100}\right) + \text{original jet size}$  namely  $\left(\frac{150 \times 300}{100}\right) + 300 = 450 + 300 = 750$ .

The answer is, use main jet 750 and the appropriate needle-jet for alcohol fuels as given in a paragraph above.

When using alcohol mixtures, the alcoholic content of which is not exactly known, "trial and error" will be necessary in finding the correct jet size, in which case it should be remembered that although quite an excessively over-rich mixture can be used on alcohol, the slightest weakness will result in trouble. Therefore, always err on the rich side for the start of the "trial and error" tests. On the other hand, if the exact composition of the fuel should be known and you get in touch with our Technical Department, they will be able to give you a fairly close approximation of the jet size required for the alcohol mixture in question.

The sparking plug, of course, is the focal point of the "trial and error" tests. This should be examined after each run after the throttle has been cleanly cut. Any suspicion of grey at the electrodes is a sign of weak mixture and larger main jets should be immediately fitted. A perfect plug condition is a rather polished jet black colour where mica plugs are used, with a rather harsher-looking brown colour where ceramic plugs are used.

A cross-check on the plug condition can always be effected by closing the air control during the run, when no appreciable increase should be noted in the R.P.M., and, ultimately, a decrease should take place. In the event of any increase being perceptible during the closing of same, this is a definite indication of a larger jet being necessary.

Normally, when changing over from petrol to alcohol on the G.P. range of Instruments, no alteration will be necessary to the air jets fitted.

**GUARANTEE.**—The Company take all possible reasonable care in the manufacture and the quality of their products. Purchasers are informed that, any part proved to be defective in manufacture or quality, and returned to the works within six months of its purchase new, will be replaced. The Company must respectfully point out however, that its responsibility and that of its agents, stockists and dealers, is limited to this Guarantee, and that they cannot, under any circumstances, be held responsible for any loss or for any contingent or resulting liability arising through any defect. These conditions of sale and use also apply when the Company's products form part of the original equipment of machines purchased new.