

**RUNNING INSTRUCTIONS
FOR
LUCAS "MAGDYNO"
LIGHTING AND IGNITION SET
FOR MOTOR-CYCLES**



LUCAS

**DESIGNED AND MANUFACTURED BY
JOSEPH LUCAS LIMITED, BIRMINGHAM, ENGLAND.**

Instruction Booklet No 171D

MOST IMPORTANT POINTS

TO ENSURE THE BEST SERVICE FROM LUCAS "MAGDYNO" EQUIPMENT.

BATTERY. Inspect the battery regularly and keep acid level to the top of the separators, by adding distilled water. **UNLESS YOU DO THIS YOUR BATTERY WILL QUICKLY DETERIORATE.**

WIRING. Keep all connections and terminals tight. See that the cables are clear of moving parts.

DYNAMO. Keep brushes and commutator clean.

MAGNETO. Keep contact breaker clean. If necessary, polish the contacts with fine carborundum stone or fine emery cloth and afterwards wipe with cloth moistened with petrol.

Occasionally check contact breaker opening (using gauge on ignition spanner).

Replace high-tension cable if it becomes worn or perished.

HEADLAMP. Focus headlamp after fitting new bulb.

INDEX.

TO PRINCIPAL SECTIONS.

	PAGE
Battery, Lead Acid Type ...	4
Battery, Lucas-Nife Steel-Plate Type ...	6
Bowden Cable, Fitting of ...	16
Bulbs ...	10
Cut-out ...	1
Dynamo ...	1 & 6
Fault Locating ...	17
Fault Finding Tables ...	19
Focussing Lamps ...	8
Hydrometer, Use of ...	5
Lamps ...	8
Magneto ...	11
Service Depots ...	22
Timing, Instructions for ...	14
Wiring of the Equipment ...	11

Running Instructions for Lucas "Magdyno" Equipment.

The "Magdyno," as the name suggests, consists of two units: the magneto for ignition and the dynamo for charging the battery.

The dynamo unit is detachable, so that owners who wish to use their machines for racing and competitions can easily strip off all their lighting equipment. A suitable fitment can be supplied which protects the gears when it is desired to run the machine without the dynamo unit.

Some "Magdyno" equipments include a headlamp which incorporates the control switch and ammeter, while others include a headlamp together with an instrument panel which houses the switches and ammeter along with the speedometer, oil gauge and other instruments.

DYNAMO.

The dynamo is mounted above the ignition unit, being driven from the magneto spindle by gears.

The dynamo is fitted with two main brushes, the positive is insulated and the negative earthed. A third brush is provided on the underside of the commutator bracket which controls the output of the dynamo by what is known as the third brush method. The object of this third brush system is to regulate the output of the dynamo at high speeds and keep it steady, independent of the speed at which the dynamo is running, as it must be remembered that the dynamo speed varies with the engine speed.

CUT-OUT.

The cut-out, which is mounted on the dynamo end bracket, is an automatic switch which prevents discharge of the battery when the dynamo is stationary. Its contacts close when the

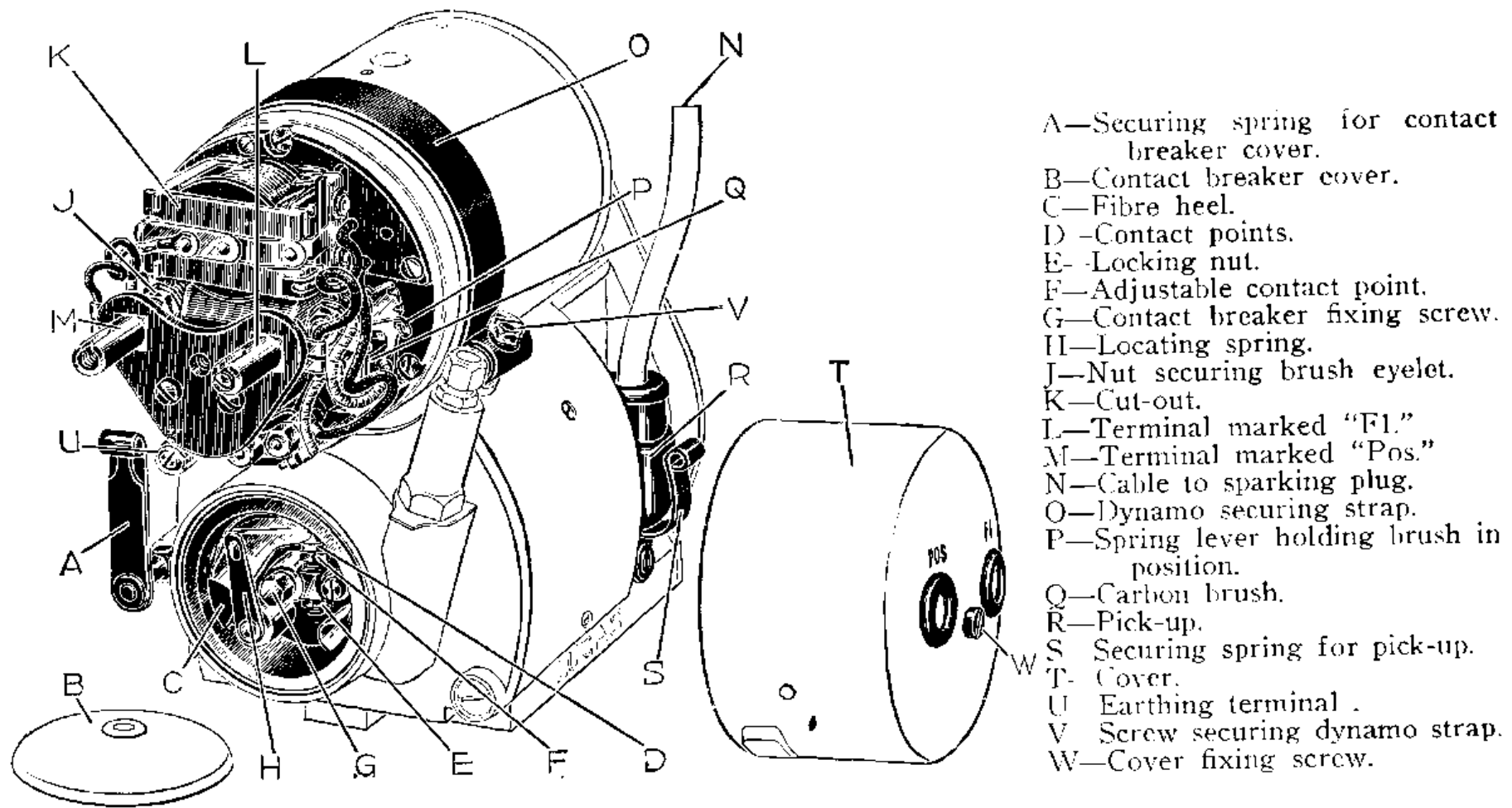

Fig. 1. VIEW OF "MAGDYNO."

Illustration shows a machine arranged for driving in an anti-clockwise direction. With a clockwise machine the positions of the terminals marked "Pos" and "F1" are interchanged, and the control brush box is situated on the opposite side.

dynamo voltage rises above that of the battery as the engine is speeded up, and open when the speed drops and the voltage falls below that of the battery. It does not prevent over-charging.

The cut-out is accurately set before leaving the Works and should not be tampered with or adjusted.

HEADLAMP.

The headlamp is fitted with a double-filament bulb. One filament is arranged to be approximately at the focus of the reflector and gives the normal driving light, while the second one, mounted slightly above the other, gives a dipped, anti-dazzling beam for use when meeting traffic or driving in fog or mist. This anti-dazzle device is controlled by a switch mounted on the handlebar or in the instrument panel. A small pilot bulb is also provided for use when the machine is stationary or for town riding.

LIGHTING AND CHARGING SWITCHING ARRANGEMENT.

The control switch which is mounted either at the back of the headlamp or in the instrument panel has the following positions:—

“Off”—Lamps off, and dynamo not charging.

“C”—Lamps off and dynamo giving about half its normal output.

“H”—Headlamp (main bulb), tail lamp and sidecar lamp (when fitted) on; dynamo giving maximum output.

“L”—With the exception that the pilot bulb is in the place of the main bulb the conditions are exactly the same as in position “H.”

The method of controlling the dynamo output is obtained by inserting a resistance in the dynamo field circuit which is automatically cut out whenever the lamps are switched on. This control arrangement has the merit of simplicity and entire absence of moving parts.

AMMETER.

This instrument gives a reading of the amount of current flowing into or from the battery. It gives an indication that the equipment is working satisfactorily.

MAINTENANCE OF BATTERY, DYNAMO AND LAMPS.

The equipment should receive regular inspection, and when necessary, should be cleaned and adjusted in accordance with the instructions given in the following pages.

BATTERY (Lead Acid Types).

Topping Up.

At least once a month, the vent plugs in the top of the battery should be removed, and the level of the acid solution examined. If necessary, distilled water, which can be obtained at all chemists and most garages, should be added to bring the level to the top of the separators. If, however, acid solution has been spilled, it should be replaced by a diluted sulphuric acid solution of the same specific gravity as the acid solution in the cell to which it is to be added. When examining the cells do not hold naked lights near the vents, as there is a danger of igniting the gas coming from the plates.

Storage.

If the equipment is laid by for several months, the battery must be given a small charge from a separate source of electrical energy about once a fortnight, in order to obviate any

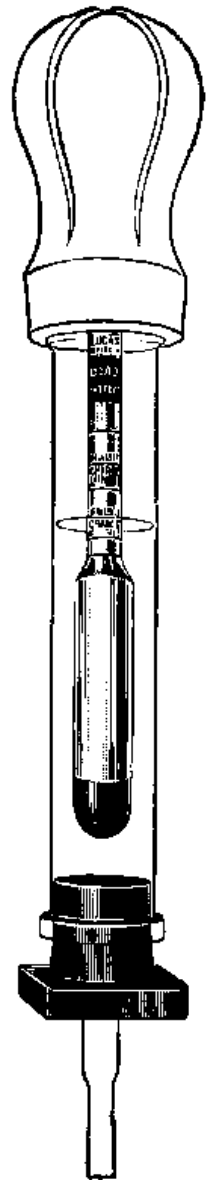

**Fig. 2. LUCAS
HYDROMETER.**

permanent sulphation of the plates. In no circumstances must the electrolyte be removed from the battery and the plates allowed to dry, as certain changes take place which result in loss of capacity.

Testing the Condition of the Battery.

It is advisable to complete the inspection by measuring the specific gravity of the acid, as this gives a very good indication of the state of charge of the battery.

An instrument known as a "hydrometer" is employed for this purpose. These can be bought at any of our Service Depots.

The specific gravity figures are:—

1.285—1.300 when fully charged, about 1.210 when half discharged, and about 1.150 when fully discharged. These figures are given assuming the temperature of the solution is about 60°F. For fuller particulars regarding temperature corrections, see our "First Charge" instructions, a copy of which can be obtained on application.

Take readings of the acid in each cell. The readings should be approximately the same. If one cell gives a reading very different from the rest, it may be that the acid has been spilled or has leaked from this particular cell, or there may be a short between the plates. In this case we advise the owner to have his battery examined by a Service Depot to trace the cause and prevent the trouble from developing.

Use of the Charging Switch.

The conditions under which motor-cycles are used vary very considerably, and obviously the amount of charging a battery will require is directly dependent on the extent to which the lamps are used. However, the following suggestions will serve as a rough guide:—

The switch should be left in the "C" position for about 1 hour daily. This time should only be increased if the period of night running is considerable, or when the battery is found to be in a low state of charge (if the specific gravity of the acid solution is 1.210 or below).

The battery must never be left in a fully discharged condition, and unless some long runs are to be taken, it is advisable to have the battery removed from the machine and charged up from an independent electrical supply.

LUCAS "NI-FE" STEEL-PLATE BATTERY.

For instructions on the latest Lucas "Ni-Fe" Steel-Plate Battery type C105, see separate booklet, a copy of which can be obtained on application.

DYNAMO.

Before removing the dynamo cover for any reason, **disconnect the positive lead of the battery** to avoid the danger of reversing the polarity of the dynamo, or short circuiting the battery, either of which might cause serious damage.

The lead from the positive battery terminal (about 1ft. long) is connected to the lead from the switch by means of a brass connector. To disconnect, remove the rubber shield and unscrew the cable connector; care must be taken that it does not touch any metal part of the frame as this will short circuit the battery. When connecting up again, do not forget to pull the rubber shield over the connector.

Brushes.

Examine the dynamo brushes, they can be removed from their holders when the spring lever is held aside. They should slide freely in their holders, and make good contact with the commutator. If the brushes are dirty or greasy, clean them with a cloth moistened with petrol.

When replacing the brushes, care must be taken that they are replaced in their original position.

After long service, when the brushes have become worn so that they will not bear properly on the commutator, they should be replaced. It is recommended that none but genuine Lucas brushes are fitted as these are specially made and will give the best results and the longest life. We advise owners to have the brushes fitted at a Lucas Service Depot so that they can be properly "bedded" to the commutator.

Commutator.

Keep the commutator clean and free from oil. The best way to clean the commutator is, without disconnecting any leads, to remove from its holder one of the main brushes, and inserting a fine duster, hold it by means of a suitably shaped piece of wood against the commutator surface, at the same time turning the engine so as to rotate the armature.

Lubrication.

As all the bearings and the gear wheels are packed with grease before leaving the Works, lubricators are not provided. After the motor-cycle has run several thousands of miles, the "Magdyno" should be dismantled for cleaning, adjustment and repacking the bearings and gear wheels with grease. This is carried out, preferably at the nearest Lucas Service Depot.

LAMPS.

REPLACEMENT OF BULBS AND FOCUSING.

Headlamp Types H52 and S51.

To remove the lamp front, press the front rim evenly and then rotate to the left (looking at the front of the lamp).

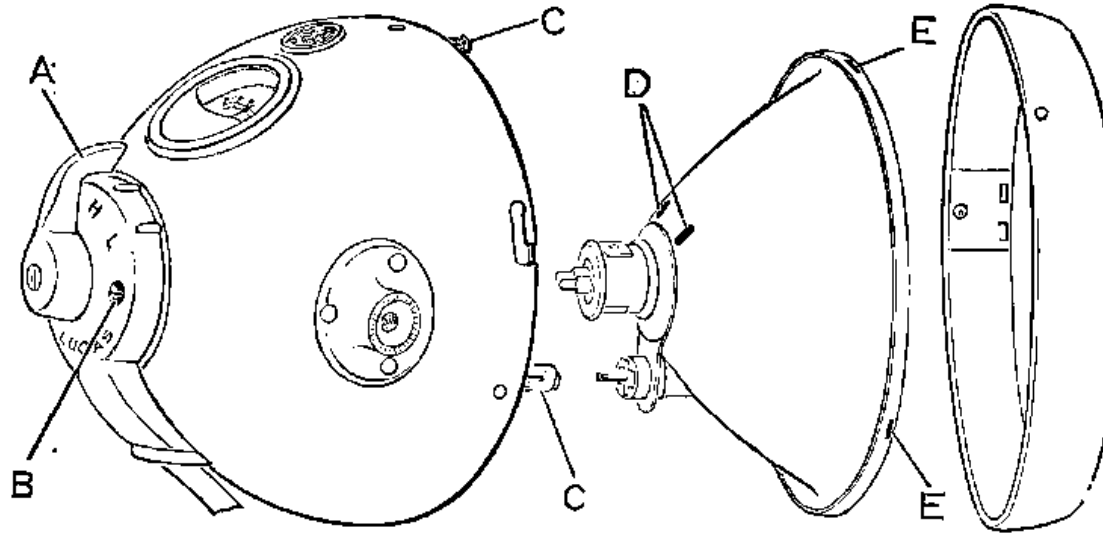

Fig. 3. HEADLAMP TYPE H52 DISMANTLED.

- | | |
|-----------------------|---|
| A—Switch. | D—Apertures through which light passes to illuminate ammeter. |
| B—Fixing Screw. | E—Slots in reflector rim. |
| C—Reflector supports. | |

When removing the main bulb for replacement, screw it out two or three turns in an anti-clockwise direction. This will enable the bulb to be withdrawn easily. Care should be taken that the bulb is fitted the correct way round, *i.e.*, with the dipped beam filament above the centre filament.

To enable the lamp to be focussed, the bulb holder is arranged so that it can be adjusted. By turning the bulb in a clockwise direction it is moved inwards, and by turning it in an anti-clockwise direction, it is moved outwards. The best position can be readily found by trial. The normal driving light should, of course, be switched on while focussing is being carried out.

In adjusting the bulb, it is important that it is given a complete turn at a time so that the filaments are in the correct position; a spring stop is incorporated in the bulb holder which indicates every time the bulb has been given a complete turn by a click action.

Headlamp Type MC140.

To remove the lamp front, slacken the fixing screw and lift the front from the body.

To focus the lamp, withdraw the reflector from its three supports and slacken the clamping clip on the bulb holder at the back of the reflector. This will enable the bulb holder to be moved backwards and forwards to obtain the best results. Lock the adjustment by tightening the clamping clip.

Headlamps Types DU42D and DU142D.

The lamp front and reflector can be withdrawn for bulb replacement when the fixing clip is pressed back. When re-fitting locate top of rim first.

To remove bulb holder, press back the two securing springs.

With some lamps the main bulb can be focussed by removing the lamp front and reflector and slackening the clamping screw which secures bulb holder. Move the bulb and holder until the best results are obtained and finally tighten the clamping screw.

Headlamp Type MP40.

The lamp front and reflector can be withdrawn for a bulb replacement when the fixing screw is slackened.

To remove the bulb holder, press down the ends of the securing springs and withdraw them from the slots in which they locate.

To focus the head lamp, remove the lamp front and reflector and slacken the clamping

screw which secures the bulb holder. Move the bulb and holder until the best results are obtained, and finally tighten the clamping screw

Side-car Type R370.

The front together with the reflector can be removed by slackening the fixing screw. The bulb holder can be withdrawn from the back of the reflector for bulb replacement. The bulb holder is provided with alternative locations for the bulb. Each position should be tried for the best result.

Tail Lamp Type MT110.

The rear portion of this lamp is removed for a bulb replacement by giving it half a turn to the left when it becomes detached from its fixing.

Tail Lamp Type MT210.

The rear portion of this lamp is detached for bulb replacement by depressing the spring catches.

Stop Tail Lamp Type ST20.

To remove the front of this lamp for a bulb replacement, move aside the spring catch which secures it, at the one end of the lamp. When refitting the front, first locate the slot with the tongue on the body, then secure it by means of the spring catch.

REPLACEMENT BULBS.

When the replacement of any bulb is necessary, we strongly recommend that Lucas Official bulbs are used. The filaments are arranged to be in focus and give the best results with our reflectors. Particulars of replacement bulbs are as follows:—

FOR.	No.	WATTS.	REMARKS.
Headlamp (driving and dipped beam lights).	624 DVMC	24 & 24	Special double filament gas filled bulb.
Headlamp (pilot light), Sidecar, Tail and Stop Lamps.	B.A.S.8.S	3	Centre contact bulb.
Panel Lamps.	B.A.S.8.S or 353MES	3 1.05	Centre contact bulb. Screw cap type.

CLEANING.

The lamp reflectors are protected by a transparent and colourless covering, which enables any accidental finger marks to be removed with a soft cloth or chamois leather, without affecting the surface of the reflector. On no account should any metal polishes be used on Lucas reflectors. Ebony black finishes can be polished with a good furniture or car polish. Chromium plated finishes only need wiping over with a damp cloth to remove dust or dirt.

WIRING OF THE EQUIPMENT.

Before making any alteration to the wiring, or removing the switch from the back of the headlamp, or from the instrument panel, disconnect the positive lead at the battery to avoid the possibility of short circuits.

All cables to the type H52 headlamp are taken directly into the switch which can be easily withdrawn from the lamp body when the two fixing screws "B" (Fig. 3) are removed.

The ends of all the cables are identified by means of coloured sleeveings. The colour scheme and the diagram of connections are given at the end of the booklet. When making a connection to the switch, proceed as follows:—Bare about $\frac{3}{8}$ in. of the cable, twist the wire strands together and turn back about $\frac{1}{8}$ in. so as to form a small ball. Remove the grub screw from the appropriate terminal and insert the wire so that the ball fits in the terminal post. Now replace and tighten the grub screw; this will compress the ball to make a good electrical connection.

MAINTENANCE OF THE MAGNETO.

The magneto portion of the Magdyno requires very little attention to ensure it gives its best service.

Cleaning.

Occasionally examine the contact breaker, the contacts "1" (Fig. 1) must be kept clean and free from any traces of oil. If the contacts are burned or blackened they may be

cleaned as follows :—Withdraw the contact breaker from its housing by unscrewing the hexagon headed screw "G" by means of the magneto spanner. The whole contact breaker can then be pulled off the tapered shaft on which it fits. Now push aside the locating spring "H" and prise the rocker arm off its bearings, when it will be possible to begin cleaning the contacts. Polish them with very fine carborundum stone or fine emery cloth, and afterwards wipe with a cloth moistened with petrol. Care must be taken that all particles of dirt and metal dust are wiped away.

Racing type Magdynos (Types MSR1 and MSRV) are fitted with platinum contacts. Keep the contact breaker free from petrol as its presence is detrimental to the contacts.

Before replacing the contact breaker, feel if the cam is dry. If necessary, it should be given the slightest smear of vaseline to prevent wear of the fibre heel of the rocker arm.

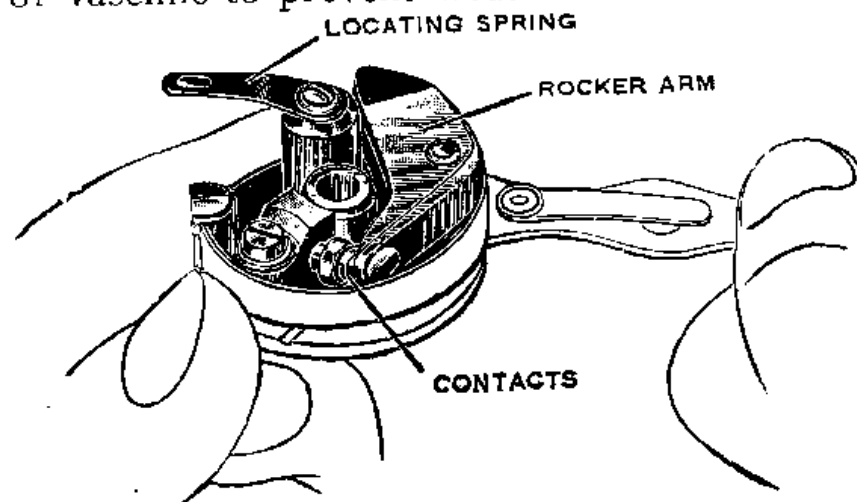

Fig. 4. VIEW OF CONTACT BREAKER SHOWING METHOD OF REMOVING ROCKER ARM FOR CLEANING CONTACTS.

When replacing the contact breaker, care should be taken to ensure that the projecting key on the tapered portion of the contact breaker base engages with the key-way cut in the

armature spindle, or the whole timing of the magneto will be upset. The hexagon-headed screw should be tightened up with care; it must not be too slack, nor must undue force be used.

Next remove the pick-up "R" (Fig. 1) (there are two in Magdynos for two cylinder engines). Wipe the moulding clean with a dry cloth. See that the carbon brush moves freely in its holder, being careful not to stretch the brush spring unduly.

With the pick-up still removed, carefully clean the slip ring track and flanges by holding a soft cloth on the ring by means of a suitably-shaped piece of wood, while the engine is slowly turned round.

Adjustment of the Contact Breaker.

The contacts only need adjustment at long intervals, and unless the gap varies considerably from the gauge (12 thousandths of an inch), the owner is warned that it not desirable to alter the setting. To adjust, turn the engine slowly by hand until the points are seen to be fully opened. Then slacken the locking nut "E" (Fig 1), and rotate the contact screw by its hexagon head until the gap is set to the gauge on the magneto spanner. After the adjustment, tighten the locking nut.

ADJUSTMENT OF SPARKING PLUGS.

The plug electrodes burn away slightly with service, and thus, in time, the gap length increases. Occasionally examine and clean them, adjusting them if necessary to the right setting; this should be about 20 thousandths of an inch.

USE OF IGNITION CONTROL.

The ignition control should be retarded for starting, but advanced as soon as the engine is running at speed. For normal running the ignition should be kept in the advanced position, and should be retarded only when the engine is pulling slowly on full throttle, *e.g.*, when hill climbing.

INSTRUCTIONS FOR TIMING.

For Twin and "V" Cylinder Engines.

1. Slacken the magneto coupling securing nuts on the armature spindle, or the magneto chain sprocket to enable the "Magdyno" to be turned independently of the engine.

2. The order of firing having been ascertained, rotate the engine till No. 1 Piston is at the top of its compression stroke (that is, on top dead centre). On "V" twin cylinder engines, the rear cylinder is usually No. 1.

3. Remove No. 1 pick-up and turn the "Magdyno" spindle forward, *i.e.*, in the normal direction of rotation, until the brass segment of the slip-ring can be seen.

4. With the "Magdynos" provided with variable ignition, the ignition control or the timing lever should be moved to the fully retarded position, that is, to the limit of its travel in the forward direction.

5. Remove the contact breaker cover and turn the magneto spindle in its normal direction of rotation until the fibre heel "C" (Fig. 1) begins to rise on the inclined plane of the cam ring just sufficiently to separate the points "D." This position is the firing point, and the magneto drive should be permanently fixed in this position.

NOTE.—The above setting is standard for most types of engines; that is, the magneto is fully retarded when the piston is on top dead centre. In all cases, however, the engine-maker's instructions should be consulted when retiming any magneto.

6. It is always advisable to check the timing after tightening up, to ensure that no movement has taken place.

For Single Cylinder Engines.

The timing may be proceeded with exactly as for two cylinder engines, except for the obvious fact that there is no firing order to be ascertained.

Engines with Fixed Ignition.

The magneto is usually timed to fire at an angle of from 15° to 20° before top dead centre, or about two inches measured on the flywheel rim. It is impossible to give more definite instructions, the engine maker's recommendations should be followed.

FITTING OF HIGH TENSION CABLE.

Use 7 m.m. diameter cable. Cut the cable flush to the required length. Remove the pick-up and from it withdraw the carbon brush "A" (Fig. 5). Slacken the pointed screw "B," and push the cable "C" hard home. Secure by tightening the screw "B," which will pierce the insulation and make good contact with the cable core.

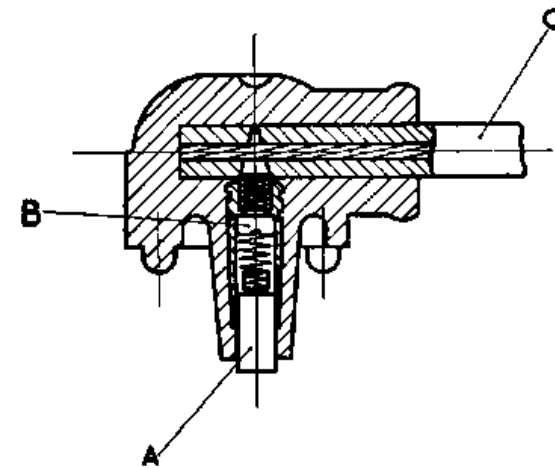

Fig. 5.
METHOD OF SECURING
CABLE TO PICK-UP.

INSTRUCTIONS FOR FITTING BOWDEN CABLE TO THE SPRING CONTROL.

When renewing the Bowden cable control, do not attempt to remove the cam from its housing. It is only necessary to remove the cable casing "B" (Fig. 6) by unscrewing the hexagon nut at the base. If the cable and plunger "C," to which it is attached is drawn upwards to its fullest extent, it will be found that the nipple into which the end of the cable is soldered comes above the top of the boss on the cam cage housing. The nipple may be now slipped sideways out of the hole "D" in the plunger in which it fits, thus detaching the cable entirely. Then thread the new cable through the casing and solder the nipple to the end of it. The nipple must be slipped sideways into the hole in the plunger and the casing screwed home. It should be noted that the cable stop "F," in the casing can be adjusted, if necessary, to take up any slight slackness in the cable covering between the magneto and the lever control.

By referring to Fig 6, it will be seen that on applying a tension to the Bowden cable, the plunger "C" will move the cam ring "A" and so alter the timing of the magneto.

Instructions cannot be given for fitting the cable to the ignition control lever, as the types of these vary with different makes of machines.

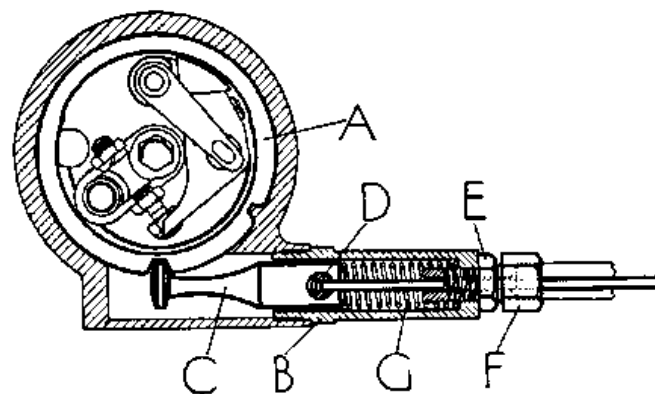

Fig. 6. SECTION OF SPRING CONTROL.

- | | |
|-----------------|-----------------------------|
| A—Cam. | D—Locating hole for nipple. |
| B—Cable casing. | E—Locknut. |
| C—Plunger. | F—Cable stop. |
| | G—Spring. |

HINTS FOR THE DETECTION AND REMEDY OF FAULTS.

Although every precaution is taken to eliminate all possible causes of trouble, failure may occasionally develop through lack of attention to the equipment or damage to the wiring. The most probable faults are tabulated, according to the symptoms which are displayed, in the fault-finding tables at the end of the booklet.

We give a few hints on the best way to make use of these tables, as the sources of many troubles are by no means obvious.

Much evidence can be gained from observation of the ammeter. If, for instance, no reading is indicated when the engine is running at, say 20 miles per hour, with the switch in the "C" position, the dynamo is failing to charge. To ensure that the ammeter is not at fault, the engine should be stopped and the switch turned to the "H" position, when a reading on the discharge side of the scale should be observed. Again, if the needle fluctuates when the engine is running steadily, an intermittent dynamo output can be suspected. The dynamo may have been neglected, and the trouble could be caused by, say worn brushes or a dirty commutator.

All connections on the equipment should be examined as follows:—First, disconnect the positive battery lead as a precaution against short circuits. Then see that all terminals on the switch are tight, move the switch through its four positions, and see that the spring

triggers "D" (Fig. 7) make good contact with the terminals. It sometimes happens that one of the leads fouls the trigger or a portion of the insulation gets clipped between the terminal and the contact. Slight rearrangement of the wire or cutting back the insulation a fraction will remedy this.

See that the leads to the two terminals on the Magdyno are tight, and also that the earthing lead from the headlamp is secured to the terminal at the side of the contact breaker housing.

Finally, re-connect the battery positive terminal and see that the end of the cable from the negative terminal makes good contact with the frame.

A possible cause of the dynamo failing to charge is the reversal of its polarity due either to the headlamp being ineffectively earthed or to the accidental "shorting" of a terminal or "live" part of the cut-out, when the cover is removed, without the precaution being taken of disconnecting the positive battery lead.

Having examined all cable connections, the polarity of the machine can be corrected by running the engine slowly, putting the switch in the "C" position, and then pressing the cut-out contacts momentarily together, when the machine should begin to generate again.

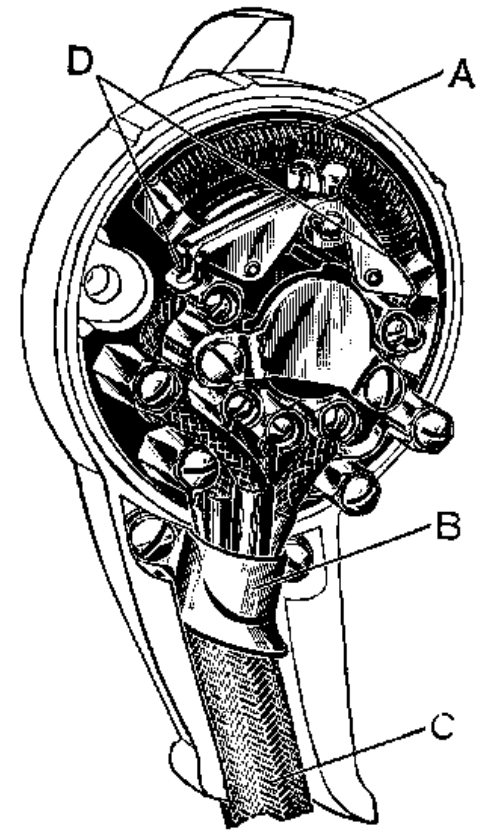

Fig. 7.

**SWITCH REMOVED FROM
BACK OF HEADLAMP
TYPE H52.**

- A—Resistance.
- B—Clamping clip for cables.
- C—Cable harness.
- D—Spring triggers.

HOW TO LOCATE AND REMEDY TROUBLE.

TABLE No. 1 (LIGHTING)

CONDITION.	POSSIBLE CAUSES AND METHODS OF DETECTION.	REMEDY.
Lamps give dim, flickering, or no light when the engine is not running.	Bulb filament broken.	Replace with new bulb.
	Bulb discoloured with use.	Replace with new bulb.
	Bulb out of focus.	Focus the bulb until the best illumination is obtained (see page 8).
	Dirty reflector or bulb.	Clean dirty reflector with chamois leather or a soft cloth.
	Severed or worn cable, or loose connections at headlamp switch, dynamo, or battery.	Tighten loose connections and replace faulty cables.
	Faulty earthing of headlamp. The earthing lead from the lamp or switch must be securely connected to the earthing terminal on "Magdyno."	Tighten loose connections and replace faulty cables.
	Faulty earthing of battery. The cable from the negative battery terminal must be securely connected to a metal part of the machine.	Tighten loose connections and replace faulty cables.
Battery exhausted. Take hydrometer readings when acid level is correct and after a run when electrolyte is thoroughly mixed. When half discharged, readings are about 1.210. When fully discharged readings are about 1.150.	Machine should be taken on the road for a long daytime run with switch in "C" position, or battery charged from independent electrical supply.	

HOW TO LOCATE AND REMEDY TROUBLE

TABLE No. 2 (LIGHTING)

CONDITION.	POSSIBLE CAUSES AND METHODS OF DETECTION.	REMEDY.
<p>After carrying out examination on Table I, and lamps still give dim, flickering, or no light when the engine is running.</p>	<p>Dynamo not charging, or charging intermittently. Ammeter should give a reading on the charge side when the machine is running at say 20 m.p.h., with switch in "C" position. Possible causes of dynamo trouble are:—</p>	
	<p>Loose connections at headlamp switch, dynamo or battery.</p>	<p>Tighten loose connections.</p>
	<p>Faulty contacts in headlamp switch.</p>	<p>Examine spring triggers and see that they make good contact with terminals (see page 18).</p>
	<p>Worn or dirty brushes.</p>	<p>Clean dirty or greasy brushes with a cloth moistened with petrol. Badly worn brushes must be replaced.</p>
	<p>Dirty commutator.</p>	<p>To clean dirty commutator, remove one of the main brushes from its holder and insert a fine duster, holding it pressed against the commutator surface by means of a suitably shaped piece of wood, at the same time slowly turning the engine. If commutator has been badly neglected, clean with very fine glass paper.</p>
	<p>Reversed polarity of dynamo.</p>	<p>To correct polarity of machine run engine slowly, put switch in "C" position, and then press cut-out contacts momentarily together.</p>

HOW TO LOCATE AND REMEDY TROUBLE

TABLE No. 3 (IGNITION)

CONDITION.	POSSIBLE CAUSES AND METHODS OF DETECTION.	REMEDY.
Engine will not fire or fires erratically.	Remove plug and allow to rest on cylinder head. If a spark occurs at plug points when engine is slowly turned over, the ignition equipment is O.K.	Look for engine defects and check ignition timing.
	If no spark occurs at plug points remove lead and plug, replace with new length of cable and test independently of plug by holding cable end about $\frac{1}{2}$ in. from metal part of engine. If magneto sparks, H.T. lead or plug is faulty.	Replace H.T. cable if perished or cracked. Clean plug electrodes, adjust gap to about 20 thousandths of an inch.
	If magneto does not spark, possible causes of trouble are:— Contact breaker gap out of adjustment and contacts dirty.	Clean dirty or pitted contacts with fine carborundum stone or fine emery cloth and afterwards with a cloth moistened with petrol. To adjust gap, turn engine slowly until the points are seen to be fully opened, then slacken locking nut and rotate fixed contact screw by its hexagon head until the gap is set to thickness of gauge. After the adjustment, tighten locking nut.
	Contact breaker rocker arm sticking.	Remove contact breaker and prise rocker arm off its bearing. Clean steel pin if necessary with fine emery cloth and then, having removed all grit, moisten with a few drops of oil before replacing the lever.
Pick-up brush worn or broken.	Fit new brush. Before fitting, clean slip ring track.	

LUCAS SERVICE DEPOTS

All owners of Lucas equipment are urged to take advantage of the facilities offered by Lucas Service. For the benefit of the users of our equipment, we have established Service Depots in all large towns, which are not only at your disposal for repairs, overhauls and adjustments, but to give free advice. If you experience any difficulty with any part of the equipment, do not hesitate to consult us, we shall be only too pleased to be of assistance. The best course to adopt is to call at our nearest Service Depot, the addresses of which are given below, when the equipment can be examined as a whole. If it is necessary to replace any part, order Genuine Lucas Spares. It is obvious that only the designers and manufacturers of the equipment are in a position to make replacement parts which will give satisfactory and lasting service. When corresponding with Depots, or when ordering spare parts, give the name, model and year of the engine; the unit of equipment; and particular part in question. Units of equipment are identified by letters and numbers stamped or moulded on some part of the article. It is essential to quote this marking to ensure that correct replacements are sent. Illustrated spare parts lists are available on application. State year, make and model and engine.

<p>BELFAST Telephone: BELFAST 7017</p> <p>BIRMINGHAM, 18 Telephone: CENTRAL 8401 (10 lines)</p> <p>BRIGHTON Telephone: PRESTON 3001 (4 lines)</p> <p>BRISTOL Telephone: BRISTOL 76001 (4 lines)</p> <p>CARDIFF Telephone: CARDIFF 4603 (4 lines)</p> <p>COVENTRY Telephone: COVENTRY 3068</p> <p>DUBLIN Telephone: DRUMCONDRA 434 (6 lines)</p> <p>EDINBURGH, 11 Telephone: EDINBURGH 62921 (4 lines)</p> <p>GLASGOW Telephone: DOUGLAS 3075 (5 lines)</p> <p>LEEDS Telephone: LEEDS 28591 (5 lines)</p> <p>LIVERPOOL, 13 Telephone: OLD SWAN 1408 (4 lines)</p> <p>LONDON Telephone: SHEPHERDS BUSH 3160 (10 lines)</p> <p>LONDON Telephone: LEYTONSTONE 3361 (4 lines)</p> <p>LONDON Telephone: PUTNEY 5131 (6 lines) and 5501</p> <p>MANCHESTER Telephone: LONGFORD 1101 (5 lines)</p> <p>NEWCASTLE-ON-TYNE, 2 Telephone: CENTRAL 25571 (3 lines)</p>	<p>3/5, Calvin Street, Mount Pottinger Telegrams: "SERVDEP, BELFAST"</p> <p>... Great Hampton Street Telegrams: "LUCAS, BIRMINGHAM"</p> <p>85, Old Shoreham Road, Hove Telegrams: "LUSERV, BRIGHTON"</p> <p>... 345, Bath Road Telegrams: "KINGLY, BRISTOL"</p> <p>... 54a, Penarth Road Telegrams: "LUCAS, CARDIFF"</p> <p>... Priory Street Telegrams: "LUCAS, COVENTRY"</p> <p>Portland Street North, North Circular Road Telegrams: "LUSERV, DUBLIN"</p> <p>60, Stevenson Road, Gorgie Telegrams: "LUSERV, EDINBURGH"</p> <p>227/229, St. George's Road Telegrams: "LUCAS, GLASGOW"</p> <p>... 64, Roseville Road Telegrams: "LUSERDEP, LEEDS"</p> <p>... 450/456, Edge Lane Telegrams: "LUSERV, LIVERPOOL"</p> <p>Dordrecht Road, Acton Vale, W.3 Telegrams: "DYNOMAGNA, EALUX, LONDON"</p> <p>757-759, High Road, Leyton, E.10 Telegrams: "LUSERDEP, LEYSTONE, LONDON"</p> <p>155, Merton Road, Wandsworth, S.W.18 Telegrams: "LUSERV, PUT, LONDON"</p> <p>... Talbot Road, Stretford Telegrams: "LUCAS, STRETFORD"</p> <p>64/66, St. Mary's Place Telegrams: "MOTOLITE, NEWCASTLE-ON-TYNE"</p>
--	---

IN ADDITION THERE ARE LUCAS—C.A.V.—ROTAX OFFICIAL BATTERY
SERVICE AGENTS IN IMPORTANT CENTRES THROUGHOUT THE COUNTRY.

SPECIFICATION

"MAGDYNO" TYPE MS.
OR SEPARATE DYNAMO
HEADLAMP TYPE
DU142D OR DU42D

WIRING DIAGRAM FOR
LUCAS "MAGDYNO" OR SEPARATE DYNAMO LIGHTING EQUIPMENT
AS FITTED TO MOTOR-CYCLES

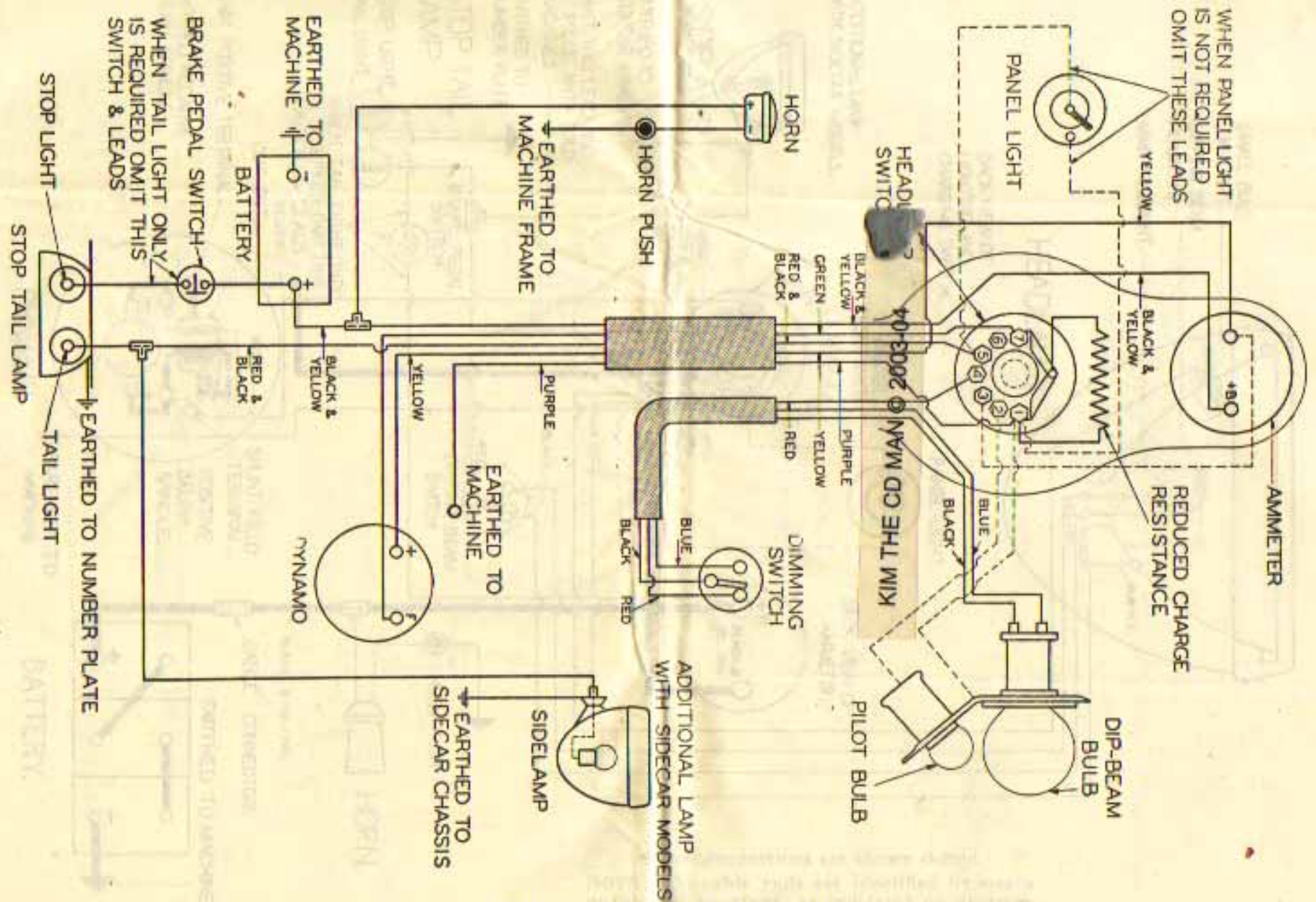

Internal connections are shown dotted.
NOTE: The cable ends are identified by means

WIRING DIAGRAM FOR LUCAS "MAGDYNO" LIGHTING & IGNITION EQUIPMENT (WITH INSTRUMENT PANEL) AS FITTED TO MOTOR-CYCLES

SPECIFICATION

MAGDYNO " TYPE MS
INSTRUMENT PANEL
HEADLAMP TYPE MC140
OR MP40

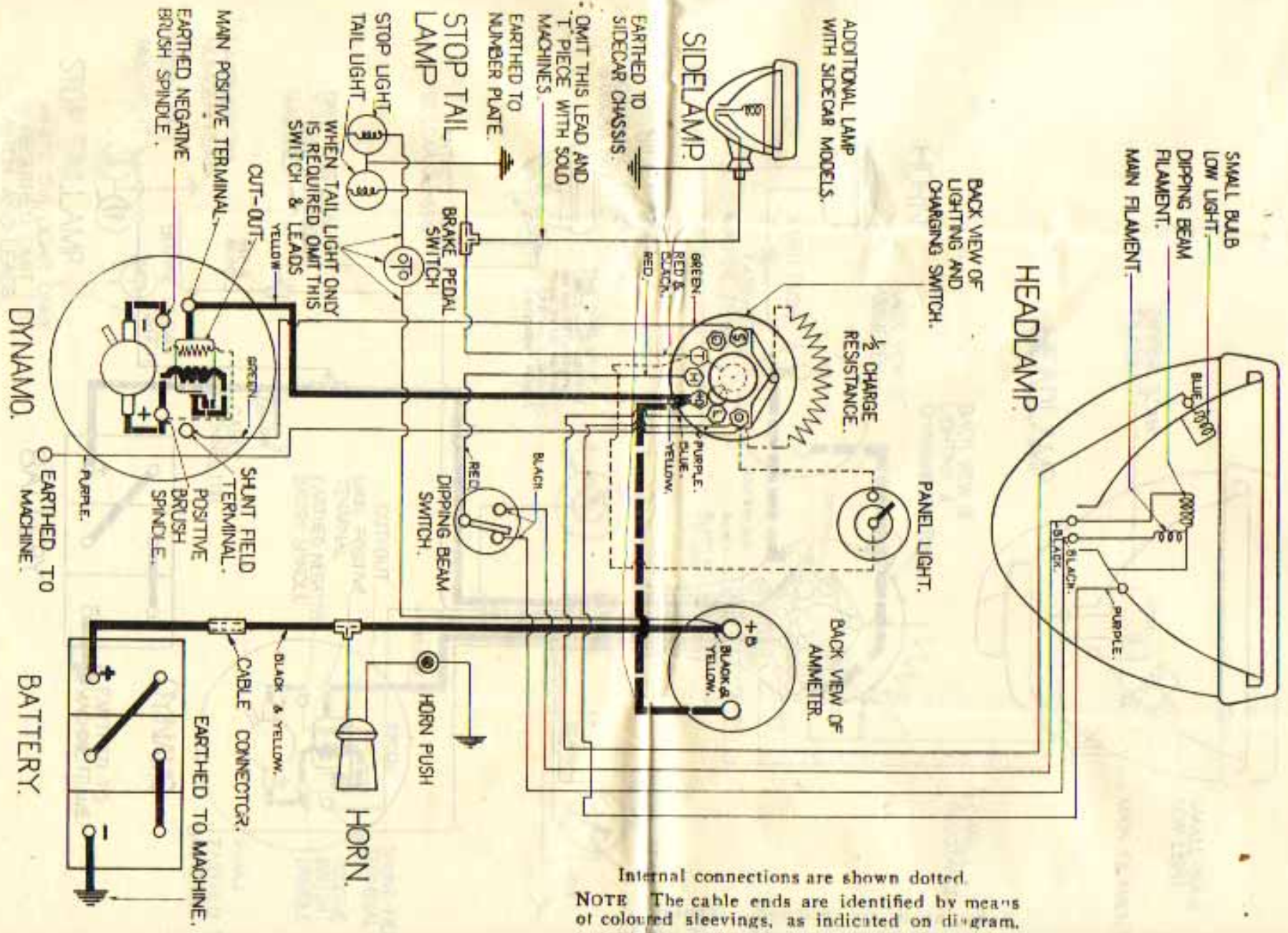

SPECIFICATION

"MAGDYNO" TYPE MS.
HEADLAMP TYPE H52.

WIRING DIAGRAM FOR
LUCAS "MAGDYNO" LIGHTING EQUIPMENT
AS FITTED TO MOTOR-CYCLES

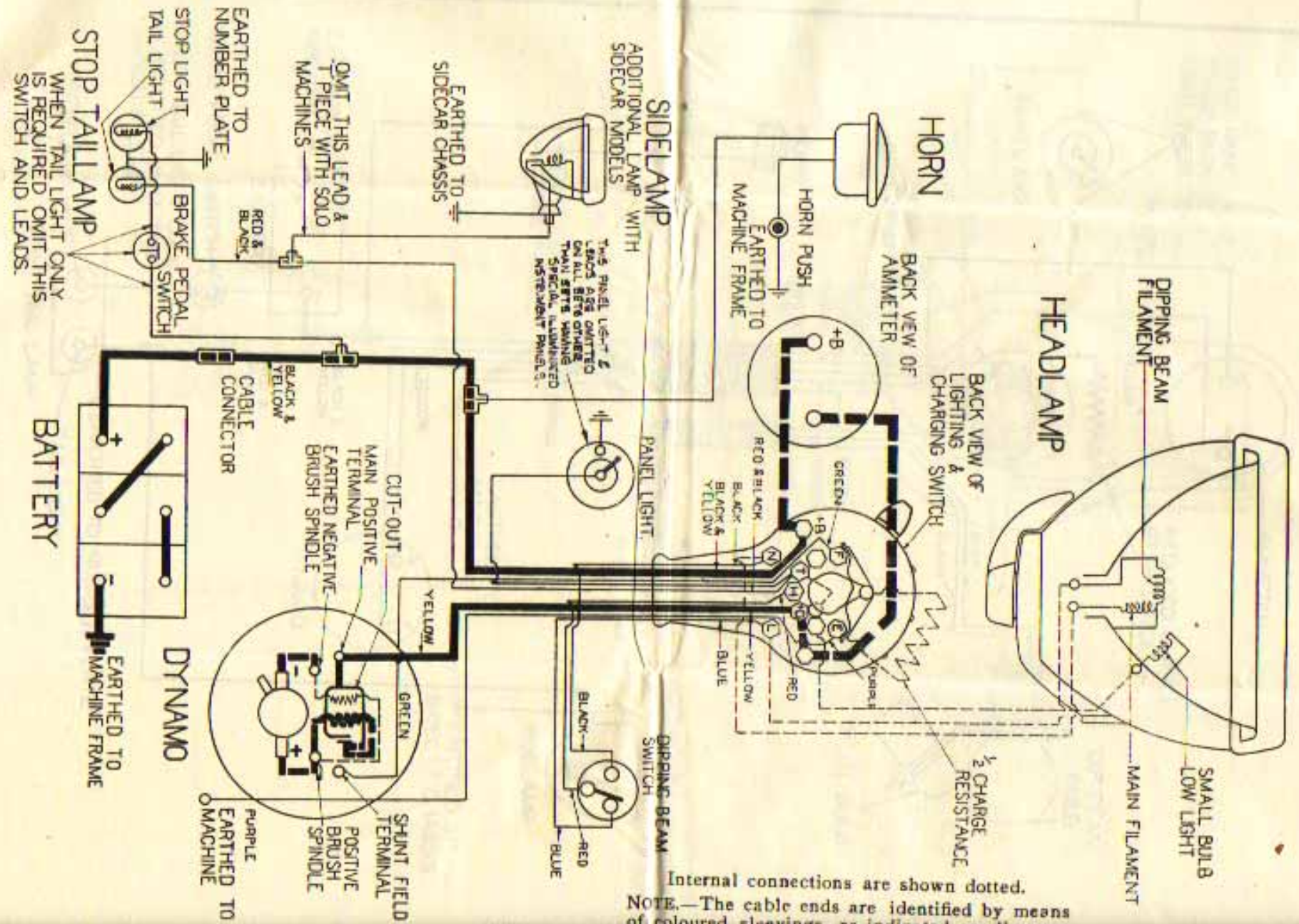

Internal connections are shown dotted.
NOTE.—The cable ends are identified by means of coloured sleeves, as indicated on diagram.