

198-X-4 Spindle for kick-starter quadrant & lever

17/09/2022

J Ready

REVISIONS				
ZONE	REV	DESCRIPTION	DATE	APPROVED

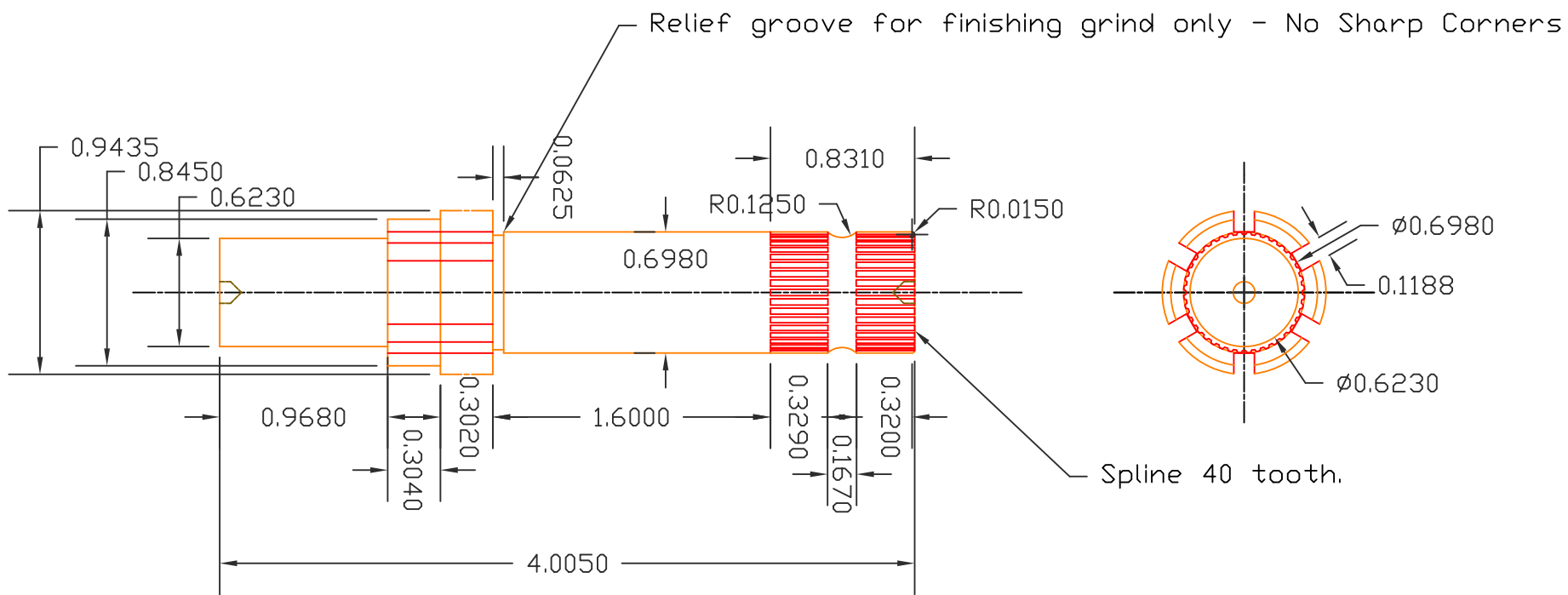

N.B.: These dimensions are taken from a new aftermarket part, purchased in 2018 and seem to suit both 1/4" & 3/8" springs. (width on largest dia.)

Spindle, for kiskstarter on CP Gearbox 1938 - 1948
 (Narrow spring).
 Main shaft is ground finish on external diameter bearing surfaces after case hardening. (except for 0.9435" dia.)

FILE NAME 15/09/2022	All dimensions in Inches		
CONTRACT NO #####	PN_198-X-4		
DRAWN	Spindle, for kick-starter quadrant & lever		
CHECK	SIZE	FSCM NO	DWG NO
APPR.	-		AJS =M=
ISSUED	SCALE 1	WEIGHT	SHEET 001

A & lever