

Motor Cycle & Cycle  
**TRADER**

TRADER AID SERIES

Servicing Data Sheet No. 13

**A.J.S. (16 MS) & MATCHLESS (G3/LS) 350 cc motor cycles  
(1956 Models)**

Manufacturer: Associated Motor Cycles Ltd., Plumstead Road, Woolwich, London, S.E.18.

All rights reserved. This service data sheet is compiled by the MOTOR CYCLE & CYCLE TRADER and the MOTOR CYCLE & CYCLE EXPORT TRADER and has been checked by the manufacturer. It is the copyright of these journals and may not be reproduced, in whole or in part without permission.

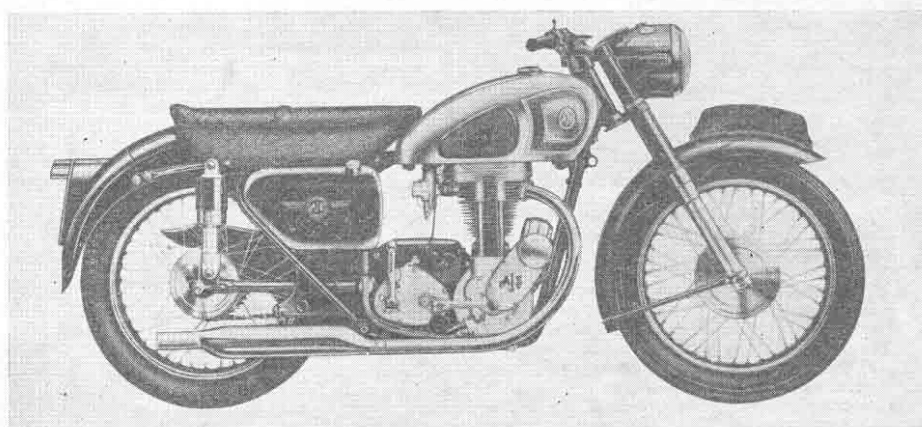

An illustration of the 1956 A.J.S. Model 16MS Motor Cycle.

**USEFUL DATA**

**ENGINE.** Single-cylinder OHV; Alloy cylinder-head and cast-iron cylinder barrel. Dry sump lubrication, incorporating a magnetic filter (integral with crankcase drain plug) and a gauze strainer in foot-pipe. Bore, 69.056 mm (2 23/32 in.); Stroke, 93 mm. (3.65625 in.); Capacity, 347 cc. (21.170 cu. ins.); Compression Ratio, (normal) 7.5 to 1.

**Valve Timing:**—Check with tappets set at .014 in. to clear camshaft quietening ramps. Take with valve 0.001 in. off seat.

**Inlet** opens 36 degrees before TDC and closes 51 degrees after BDC.

**Exhaust** opens 50 degrees before BDC and closes 30 degrees after TDC.

When resetting valve timing on 350 cc. engines, use Mark No. 1 on exhaust-cam pinion and Mark No. 3 on inlet-cam pinion.

**Valve Guides:**—should project (top of guide to boss) 1/8 in. (inlet and exhaust).

**Piston:**—split skirt, wire-wound, alloy type. Top of skirt diameter (standard) 2.7176 in. Front to rear clearance in cylinder 0.001 in. (above figures are + or -0.0005 in). Rebore cylinder and fit oversize piston when clearance at top of cylinder reaches 0.008 in. Steel gudgeon-pin (easy push fit in con-rod small-end bush and in piston) is secured by two circlips.

**Piston Rings:** Two compression (top ring taper ground, with upper side marked "top", and chrome-plated) and one scraper-ring. Ring sizes: 69.056 mm. (2 23/32 in.) by 1/16 in. compression, and 69.056 mm. (2 23/32 in.) by 1/8 in. scraper. Ring gaps: normal 0.006 in.; maximum 0.030 in.; side clearance in groove 0.002 in.

**Tappet Clearances:** (With engine just warm): Nil, (push-rods just free to rotate) with both valves closed and piston at TDC on compression stroke.

**Main Bearings:** (Drive side): 1 in. by 2 1/2 in. by 3/4 in. and 1 in. by 2 1/2 in. by 3/8 in.

**Oversize Parts Available:** Pistons and rings 0.020 in. and 0.040 in. over standard size (rebore cylinder to suit). Big end rollers 0.001 in. over standard size (usually has to be lapped).

**Carburettor:** Amal Monobloc 376/5. Main jet 376/100 size 210; pilot-jet 376/076 size 30; throttle-valve 376/060 size 3.5; choke-size 1 1/16 in.; needle jet 376/072 size 0.1065; needle position, central notch.

**Gearbox:** 4-speed with positive foot-change. Internal ratios: First Gear 2.65 to 1, Second Gear 1.70 to 1. Overall ratios: 15.44 to 1, 9.90 to 1 (18 tooth engine sprocket).

Internal ratios: Third Gear 1.308 to 1, Top Gear 1 to 1. Overall ratios: 7.63 to 1, 5.83 to 1 (18 tooth engine sprocket).

**Clutch:** Fitted with 5 steel plates, 4 friction-insert plates and 5 springs (free length new 1 1/2 in.). Spring tension: adjusting nuts 4 complete turns from fully home. Clutch-sprocket has 24 rollers of 0.250 in. dia. by 0.234 in. length. Clutch-pushrod length 9 7/8 in. Steel-ball diameter 5/16 in. Adjust cable to give 1/8 in. to 3/16 in. free movement.

**Sprockets:** Engine, 18 teeth; and dynamo-drive, 21 teeth; clutch, 40 teeth; gearbox, 16 teeth; rear wheel, 42 teeth; dynamo driven 17 teeth; magneto (drive and driven) 17 teeth.

**Chains:** Primary, 1/2 in. by 0.305 in. 66 links; rear, 3/8 in. by 0.380 in., 98 links; dynamo, 3/8 in. by 0.225 in., 49 links (endless); magneto, 3/8 in. by 0.225 in. 46 links (endless).

**WHEELS:**

**Front:** Rim WM2 by 19 in. Tyre, 3.25 in. by 19 in. ribbed. Pressures, solo (average) 18 lb. p.s.i. Pillion (average) 20 lb. p.s.i. Spokes: 40 of 11 swg by 5 7/8 in. long.

**Rear:** Rim WM2 x 19-in. Tyre, 3.25 in. x 19 in. Studded. Pressures, solo (average) 22 lb. p.s.i. Pillion (average) 28 lb. p.s.i. Spokes: 40 of 10 s.w.g. x 6 15/16 in. long. Front and rear brake-lining sizes: 6 9/16 in. by 7/8 in. x 3/16 in. (2 per wheel).

**Chain Adjustments:** (see "Transmission"): Primary 3/8 in. whip; rear 1 1/2 in. whip on stand (1/2 in. whip off stand with rider seated); dynamo 1/2 in. whip; magneto 1/2 in. whip.

**LUBRICATION GRADES AND CAPACITIES**

COMPONENT	CAPACITY	MOSPHERIC		
		Hot (above 50°F.) (summer)	Cold (32°F. to 50°F.) (temperate winter)	Extremely Cold (below 32°F.)
		S.A.E. 50	S.A.E. 30	S.A.E. 20
Engine oil tank	5 pints (2.8 litres)			
Primary chaincase	3/8 pint, 170 c.c.	50	30	20
Gearbox	1 pint (568.2 c.c.)	50	50	30
Front fork (per leg)	6 1/2 fl. ozs. (184.6 c.c.)	20	20	20
Rear leg (per leg)	3 fl. ozs. (85 c.c.)	20	20	20
Rear fork hinge bearing	1 1/2 fl. ozs. (42.6 c.c.)	140	Heavy gear oil	
Hubs and frame as grease nipples necessary		Mobil-grease No. 4, Castrol-grease Heavy, Energrease C3, Esso Pressure grease, Shell Retinax A or CD.		
Rear chain	as necessary	Mobil-grease No. 2, Castrol-grease graphited grease, Esso fluid grease, Energrease A.O. (warmed till just fluid).		
Controls, cables, etc.	as necessary	S.A.E. 30	S.A.E. 30	S.A.E. 30

Brands recommended: Mobiloil, Castrol, Energol, Essolube and Shell.

**Petrol Tank Capacity:** 3 3/4 galls. (17.04 litres).

**Dimensions:** Wheelbase 55½ in. Total length 86½ in.; width 28 in.; weight 375 lb. (standard model); ground clearance 5½ in.

**Steering Head Races:** Self-aligning floating type. 28 of 3/16 in. dia. steel balls in fork crown race. 28 of 3/16 in. dia. steel balls in main frame top race.

**Engine No.** Stamped on driving-side (LH) crankcase half.

**Frame No.** Stamped on RH side of main frame seat lug (under saddle).

#### ROUTINE LUBRICATION

(See Useful Data for grades and capacities)

Components using.

#### (1) Oil.

(a) **Main oil-tank.** Drain and refill at 1st 500 miles; 1st, 1,000 miles and subsequently at every 5,000 miles. At same time, clean magnetic-filter (crankcase drain-plug) and feed-line gauze strainer.

(b) **Gearbox.** Drain and refill at 1st 500 miles and add 2 fl. ozs. (60 cc.) every 1,000 miles.

(c) **Primary chaincase.** Check oil-level every 500 miles with machine vertical (minimum level 3/16 in. below inspection orifice).

(d) **Front forks and rear suspension legs.** Check oil content every 5,000 miles and top up. (See "Fork and frame servicing".) Very lively action indicates low oil content.

(e) **Control levers, cables, brake rod joints, centre and prop stand hinges.** Lubricate as necessary every 1,000 miles.

(f) **Air filter.** (If fitted). Wash element in petrol, dry and re-oil every 1,000 miles. Renew at 10,000 miles.

#### (2) Grease.

(a) **Wheel hubs.** Packed on assembly. Grease sparingly every 1,000 miles.

(b) **Brake expanders.** Grease sparingly every 1,000 miles.

N.B. (a) and (b) must not be over-lubricated.

(c) **Steering-head bearings.** Grease sparingly every 1,000 miles.

(d) **Brake-pedal spindle and Speedo-gear-box.** Grease sparingly every 3,000 miles.

#### (3) Melted grease.

**Rear-chain.** In wet weather remove, clean and immerse every 1,000 miles. In dry weather remove, clean and immerse every 3,000 miles.

#### (4) Heavy gear oil.

**Rear-fork hinge.** Top up to level of small screw as necessary.

#### ENGINE

#### (1) Decarbonising.

Necessary only when loss of power or excessive pinking occurs. Remove petrol-tank and tappet-inspection cover. Set piston TDC both valves closed. Remove oil-feed pipe (at rocker-box), spark-plug, valve-lifter cable, engine steady-bracket and (9) rocker-box holding bolts. Lift up right side of rocker-box, withdraw pushrods (noting position of each for re-assembly) and remove rocker box. Remove exhaust and silencer bracket-nuts, and take off exhaust-assembly. Remove carburettor and tie up on saddle. Unscrew (4) cyl-head bolts and remove cylinder-head and pushrod tubes. Place cylinder-head flat on bench. With finger in spring-coils, pull upwards, removing springs. Lightly tap valve-spring collars freeing collars. Lift out collars and take off spring collars. Press out valves. If guides require replacing, clean top end (inlet), heat cylinder head and press downwards and out. With exhaust guide, heat and press upwards first, enough to allow removal of circlip, then remove as for inlet. Remove carbon from piston and head with soft brass-scraper. Do not use abrasive e.g. emery.

Warm cyl-head, press in guides ensuring oil-holes align, and guide top is ¼ in. from boss. Cut valve-seats to 45 degrees (if guides not replaced, cut seats only if pitted). If valves

pitted, reface to 45 degrees, grind in lightly, using fine paste and tool 017482. Oil valve guides and stems and refit using tool 018276 (see fig. 1) ensuring spring-prongs seat flat on boss and collars fit into 2 rings on valve stem. Do not remove cylinder unless bore scored or worn. If removed, fit piston slot facing forward, chrome-ring on top with polished edge lowest, and stagger rings 120 degrees. Fit metal washer and rubber gaskets on pushrod tubes, and press into head. Place annealed gasket on cylinder, rubber rings over tappets and fit cylinder head with 4 bolts, pulling down evenly. Set piston TDC, both tappets down. Place rocker box gasket on cyl-head. Place rocker box on head, raise right side slightly, insert pushrods (as removed), lower rocker-box and secure with 9 bolts tightening evenly. Set tappets just free to rotate. Turn engine over several times. Fit steady bracket, valve-lifter cable and oil-feed pipe. Set tappets (push-rods free to rotate with no up and down lift). Fit rubber-seal and tappet cover securing finger-tight. Fit spark plug, HT lead, petrol tank and exhaust pipe. Warm engine and reset tappets.

#### (2) Retiming Ignition.

Set CB points 0.012 in. Remove spark plug, tappet cover and magneto chain-cover. Un-

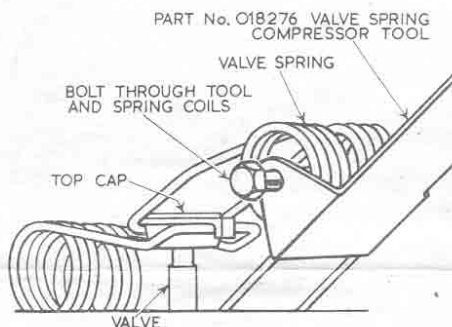

Fig. 1. Use of valve spring compressor. Engage spring in groove in top cap. Insert bolt through holes in tool and coils of springs. Pull upwards and outwards until open ends of springs can be rested on seat, then press down spring. Maintain pressure with fingers, remove bolt and tool, then finally press spring prongs home.

screw camshaft sprocket nut 3 turns. Lever sprocket off taper. Set piston TDC, both valves closed. Insert rod in plug-hole against piston, mark rod flush with plug-hole, remove, mark ¼ in. higher, insert against piston, turn engine backwards till higher mark flush with plug hole. Secure AT Device (with wood wedge) in advanced position. Turn magneto shaft (anti-clock at sprocket end) till CB points just opening. Press sprocket on taper, tighten nut ensuring magneto-shaft and engine do not rotate. Re-check that piston position and opening of CB points occur as above. Remove wood wedge. Fit tappet cover, spark plug and chain cover.

#### (3) Removing and Refitting Oil-Pump Plunger (only if necessary).

Remove rocker-feed pipe (at pump-end cap), pump ends and plunger guide screw and pin. Press out plunger towards rear. Assemble in reverse order with new gaskets, ensuring: (1) guide pin engages plunger groove before pump end caps are fitted. (screw in with fingers till groove is felt); and (2) gaskets do not cover oil holes.

#### (4) Resetting Valve Timing (see fig. 2).

With magneto-drive and inner chain-cover removed, withdraw camshafts. Align crankshaft-pinion mark with centre of inlet (rear) camshaft bush. Insert inlet camshaft No. 3 dot, enmeshing crankshaft pinion mark. Turn engine forward, aligning crankshaft pinion mark

with centre of exhaust-camshaft bush. Insert exhaust camshaft No. 1 dot enmeshing crankshaft pinion mark. Fit new gasket over timing chest dowels. Fit inner chain-cover, sprockets and chain. Set ignition as above.

#### (5) Engine Overhaul.

Remove petrol-tank, carb., valve-lifter cable, rocker box oil feed pipe and exhaust system (see para. 1). Drain oil from sump drain-plug and oil-pipe connections at crankcase. Remove footrest n/side, rear brake-pedal, front chain-case outer, clutch, engine and dynamo sprockets and inner chaincase. Loosen fixing strap and remove dynamo. Remove magneto chain-cover, unscrew AT device nut extracting unit from shaft. Remove magneto drive-chain, sprocket, inner chain-cover and camshafts (see para. 4). Remove engine fixing-bolts, lift off front engine-plate and magneto. Tilt engine forwards and lift out. Unscrew timing pinion nut (left-hand thread), extract pinion. Remove oil-pump plunger (see para. 3). Remove cylinder-head (see para. 1) cylinder and piston. Undo crankcase bolts, separate crankcases, remove flywheel assembly. If timing-side shaft replaced, ensure timing-pinion keyway exactly aligns with centre of crankpin hole in flywheel. If crankpin oversize rollers (0.001 in.) fitted assembly must be lapped in. True up fly-wheel-assembly to 0.0005 in. tolerance at shafts and flywheel rims. Fit timing-side main-shaft bush over shaft, insert oil-can nozzle in oil hole and operate till oil appears at big-end assembly sides. Blow out all oilways in crankcases and clean c/cases thoroughly. If bearings or bushes worn, replace, heating crankcases to facilitate removal and fitting, ensuring that spacing-washer is fitted between drive-side ball bearings, and that timing-side bush oil-hole aligns with oil passage in crank-case and cut away clears oil plunger. Assemble crank-cases with jointing compound on crankcase faces. Fit, in this order, piston, cylinder, timing-pinion, oil-pump, plunger (see para. 3), cylinder head, push-rods and rocker box. Fit engine to frame (magneto on front engine plate). Fit timing-pinions (see para. 4), and inner mag. chain-cover. Fit AT device, magneto-drive chain and drive-sprocket securing AT device to shaft, then setting ignition timing. Fit magneto outer chaincover, oil pipes, sump drain-plug, carb., valve-lifter cable, exhaust assembly, petrol tank, front chain-case and transmission assembly, and top up oil in c/case and tank. Warm engine and check tappet clearances.

#### TRANSMISSION.

**Chains:**—See data for correct whip, measured always midway between sprockets. Set at tightest point of chain. **Dynamo:** Check through front chaincase inspection cap hole. Loosen fixing-strap bolt, manually rotate dynamo anti-clockwise. Tighten fixing-strap bolt. Recheck tension, replace cap. **Magneto:** Remove cover. Loosen bolt through platform rear. Lever platform upwards to tighten chain. Tighten platform-bolt. Replace cover. **Primary Chain:** Check through front chain case inspection cap hole. Remove engine-plate cover. Release locknut on cross-head bolt adjuster, and bolt through engine-plate slot. Screw adjuster into cross-head, and pull on rear chain to tighten. Screw adjuster out of cross-head, lever g/box forward to loosen. (Ensure rear chain is not also tight.) Secure locknut, tighten bolt through engine plate slot. Replace engine plate-cover and inspection cap. **Rear Chain:** Check with machine on stand, ¼ in. whip, or off stand with rider mounted, ½ in. whip. Release wheel spindle and dummy spindle nuts, and adjuster-nuts. Screw adjusters out evenly until tension correct. Secure locknuts, wheel-spindle and dummy spindle-nuts. Reset rear-brake adjustment. Always reset rear chain after primary-chain adjustment.

#### CLUTCH

**Adjustment:**—For free movement see data.

Release cable-adjuster locknut, screw adjuster full in. Remove clutch-dome cover. Release lock-nut on clutch thrust cup, screw thrust-cup against pushrod, unscrew  $\frac{1}{2}$  turn, tighten locknut. Finally, set free movement on cable adjuster. **Clutch slip:** If operating mechanism adjustment set correctly and spring nuts set 4 turns out from full in position, remove springs and clutch plates. Replace springs if weak or shorter than new spring. Wash clutch-plates in petrol, dry off, sandpaper friction plates if glazed. Replace if worn thin.

**CARBURETTOR**

(Amal Monobloc Type 376/5)

Needle and jet sizes are given under "Useful Data". With mechanically sound engine, i.e. ignition and timing in order, valves seatings and adjustments correct, cylinder and piston unworn, the only adjustment necessary is to tick-over setting. To do this, warm engine, screw pilot air screw fully in then unscrew  $1\frac{1}{2}$  turns, set throttle stop screw to slowest even tick-over, compensating any weak or rich mixture by screwing pilot air screw in to richen and out to weaken. **Rich setting** causes lumpy running and black smoke from exhaust; **weak setting** causes misfiring and spitting-back

oil; (g) repeat until no more oil drains off (If 6 fluid ozs. (170 c.c.) is collected, oil level was correct ( $\frac{1}{2}$  fl. oz. or 14 cc. remains in fork leg)); (h) Refit drain plug; (i) pour back exactly 6 fl. ozs. (170 cc.) oil into fork leg and refit top plug. Repeat for other leg.

**Note 1.** If forks completely dismantled and reassembled "dry",  $6\frac{1}{2}$  fl. ozs. (184.6 cc.) must be added to each leg.

**Note 2.** Oil content, per leg, may be increased up to 10 fl. ozs. (284 cc.) to deal with abnormally heavy loads and heavier-grade oil may be used to increase damping effect.

(3) **Topping up rear suspension legs.** (a) Remove one leg from machine (noting position of spacing washers); (b) grip outer tube (close to bottom pivot-lug) in suitable clamp held in a vice and loosen pivot-lug; (c) turn leg upside down and remove pivot lug; (d) pump exposed end of damper-tube several times; (e) pour oil into graduated measure; (f) repeat pumping and, finally, leave leg to drain into measure. (If  $2\frac{1}{2}$  fl. ozs. (75 cc.) is collected then oil-level was correct ( $\frac{1}{3}$ rd fl. oz. or 10 cc. remains in leg.)). (g) Pour back exactly  $2\frac{1}{2}$  fl. ozs. (75 cc.) of oil and refit pivot lug securely. Repeat for other leg.

**Note.** For abnormal loads, SAE 30 oil may be used instead of the SAE 20. Under no circumstances may the oil content be increased to more than  $3\frac{1}{2}$  fl. ozs. (90 c.c.).

(4) **Rear fork hinge.** See routine lubrication.

(5) **Wheel bearing adjustment (front and rear).** The outer cups of the taper wheel bearings are pressed into the hub shell when warm. The L.H. (brake) side bearing is fixed (located by circlip) and the RH bearing is adjustable by means of a threaded-sleeve screwed into the RH end of the hub, and the sleeve is locked by a circular locknut. The need for adjustment is rare, and it is essential that the bearings are not adjusted too tightly. Just perceptible rock must be present at the wheel rim (equal to approximately 0.002 in. end float). **To adjust:** Use tool Part No. 017250 for front hub locking. Use tool Part No. 010438 for rear hub lock-ring. Use tool Part No. B3334 for front hub adjusting-sleeve. (a) Remove wheel; (b) slacken circular locknut; (c) tighten adjusting sleeve (clockwise) until all slackness is taken up; (d) slacken back (anti-clockwise) adjusting sleeve  $\frac{1}{4}$  a turn. The bearing must now be pressed back against the adjusting sleeve. (e) Tighten circular locknut, ensuring that adjusting sleeve does not turn, spoiling adjustment, and that hub-cover disc is correctly positioned to give access to grease nipple.

**Note.** It is most important that front brake-cover plate outer face is flush with hub-shell edge. To adjust plate, reposition inner nut (flat face against plate) and finally tighten outside spigot-nut (see fig. 3).

(6) **Brake shoe adjustment.** When brake lining wear has caused all cable (front) and rod (rear) adjustment to be used up and the brake cam lever to take up a position of poor leverage, the position is remedied by fitting packing washers (part No. 000174) under the head of the brake-shoe thrust pins. The cable or rod adjuster must then be reset. The brake-shoes must also be centralised (incorrect centralising causes brake-squeak). Do this as follows: (to front wheel when removed and to rear wheel when refitted to machine) (a) slightly slacken brake cover plate spigot nut and (in the case of the front wheel only) the fulcrum stud nut; (b) expand brake shoes fully (extension on cam lever); (c) tighten spigot nut and fulcrum stud nut.

**ELECTRICAL SYSTEM**

(1) **Ignition.**

(a) **Magneto:** Lucas type SR1 (rotating magnets), with automatic advance and retard, running at  $\frac{1}{2}$  engine speed. Check c/b points at 1st 500 miles and subsequently every 3,000

miles. Dirty, oily or burnt points should be refaced with fine carborundum-stone or fine abrasive-paper and cleaned with petrol-dampened cloth. Reset gap to 0.010 in. to 0.012 in. by slackening 2 screws securing fixed contact-plate, moving plate until gap is correct with points fully open and retighten screws. Every 10,000 miles repack armature bearings with HMP grease.

(b) **Sparking plug:** KLG FE80. Clean every 3,000 miles. Dismantle, wash in petrol, clean central firing-point with fine emery and remainder of central electrode with medium sandpaper. Scrape inside of body clear of carbon. Rewash in petrol. Reassemble, smearing internal washer with thin oil. Reset points gap to 0.020 in. — 0.022 in. by resetting side electrodes. Smear plug threads with graphite paste before refitting.

(2) **Dynamo.**

Lucas E3N-LO 2 brush type. (Negative brush insulated and positive brush earthed). Keep brushes in good condition and free in

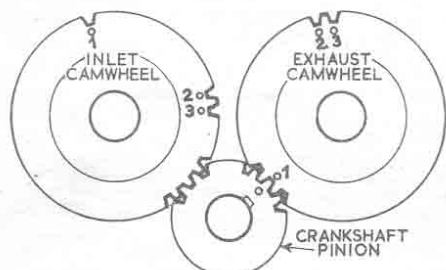

Fig. 2. Setting valve timing using marks on camwheels and crankshaft pinion.

through carburettor. If satisfactory tickover unobtainable, remove pilot jet and check for blockage.

**Faults and corrections.** (1) **Flooding,** remove float needle, clean seating and/or replace float needle if taper end damaged. **Do not grind-in needle.** (2) **Weak mixture** (shown by over-heating, burned plug points, spitting-back at all throttle openings and by loss of power). Reface carburettor flange-surface to cylinder head; tighten mixture chamber top, check main jet size and throttle needle position, suspect wear on inlet valve or guide. (3) **Heavy fuel consumption.** Check for mal-alignment of air feed holes in mixing chamber intake and jet block and replace jet block if necessary. Check for punctured float, faulty float-needle seating, faulty float-needle, loose main-jet, incorrect jet-needle setting, air-valve partially closed, or incorrectly fitted pilot-jet.

**FRONT FORKS, FRAME AND WHEEL SERVICING**

(1) **Adjusting steering head races.** (Races are floating, self-aligning type.) To adjust—(a) Raise front wheel clear of ground; (b) slacken (2) fork-crown pinch-screws; (c) slacken steering-column domed nut; (d) slowly tighten down nut under domed nut until no (perceptible) play is felt and yet head is perfectly free to turn; (e) lock adjustment by tightening domed nut.

(f) **Re-tighten fork-crown pinch screws.** (2) **Topping up fork oil level.** (a) support machine vertically with weight on both wheels; (b) slacken inner tube top-bolts; (c) remove drain-plug from one slider and catch oil in 10 fl. ozs. graduated measure; (d) refit drain-plug; (e) pump damper-rod (attached to inner tube top-bolt) up and down vigorously and wait 2 minutes; (f) remove drain plug and catch

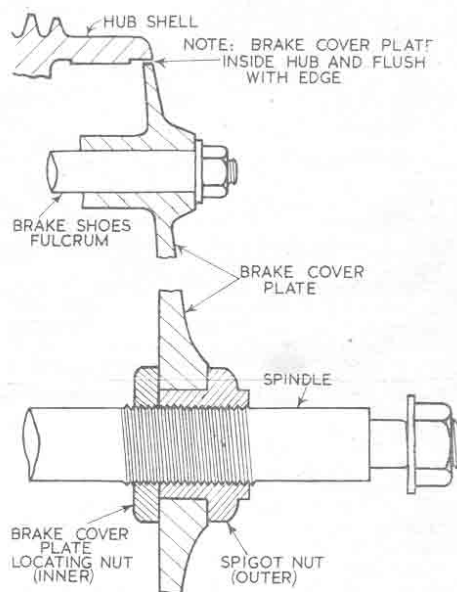

Fig. 3. Sketch showing positioning of front brake cover plate

holders, commutator clean (wiped with petrol rag) and springs serviceable. Every 10,000 miles dismantle dynamo, replace worn parts and reassemble packing bearings with HMP grease.

**Testing dynamo (on machine)** if ammeter shows "no charge".

(a) Check that regulator, dynamo and battery cables are connected correctly (see Wiring Diagram). (b) Disconnect cables from dynamo "D" & "F" terminals and "bridge" terminals with wire. (c) Run engine at tickover and connect negative lead of moving coil voltmeter (0.10 volts) to one dynamo terminal and the positive lead to earth. (d) Gradually increase engine speed (up to 1,000 r.p.m. only) and the voltage should rise steadily to 10 volts. If reading OK, then proceed to test regulator unit. If, however:

(1) No reading, then remove dynamo cover-band, check dynamo-brushes for wear, sticking, security of connections, brush springs for tension and commutator for cleanliness. Rectify as necessary and retest dynamo.

(2) A low reading of (a) approximately  $\frac{1}{2}$  volt, then field-winding is probably faulty. (See note 1). (b) Approximately 14-2 volts, then armature is probably faulty. (See note 2). In

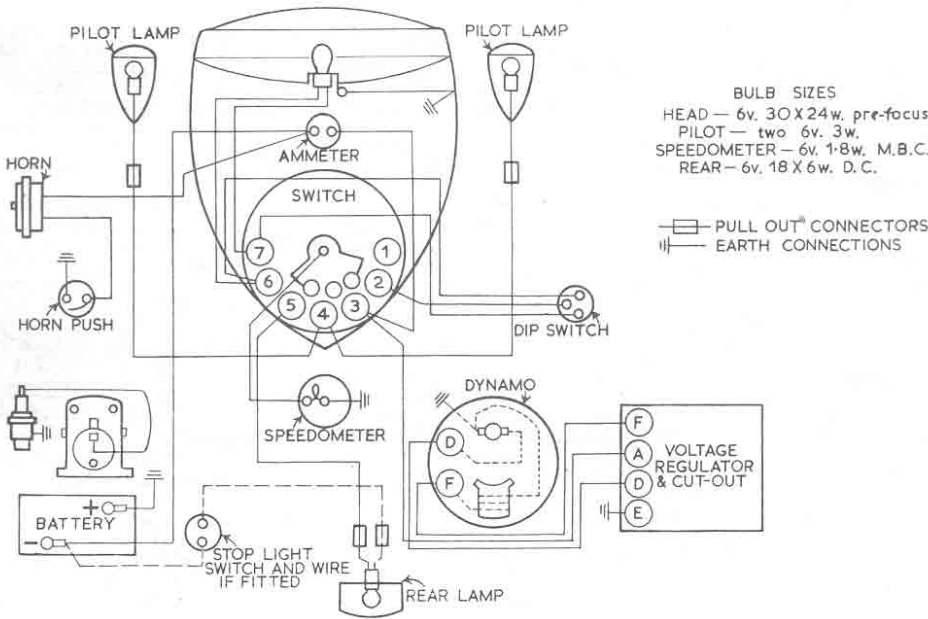

General wiring diagram; bulb details are also given in tabular form.

**ELECTRICAL DATA**

**Magneto**—Lucas model SR1 (part No. 42294A); Rotating Magnet; Automatic Advance and Retard Unit (part No. 47544D); Anti-Clock Rotation; C/B Gap .012 in.; Ignition Timing  $\frac{1}{2}$  in. (39 deg.) before T.D.C. fully advanced.

**Spark Plug**—K.L.G.; FE 80; 14 mm.;  $\frac{1}{4}$  in. reach. Points Gap .020 in. to .022 in.

**Dynamo**—Lucas E3-N (Part No. 20028B); Anti-clock Rotation; Cutting-in Speed 1250/1500 r.p.m. at 7 volts; Output, 5 amps at 7 volts.

**Voltage Regulator**—Lucas MCR2; Part No. 37224A); Open Circuit Voltage (at 68 deg. F.) 7.6 to 8 volts.

**Battery**—Lucas 6 v. 12 amp/hr.; PUZ 7E II; Supplied "Dry-Charged".

**Headlamp**—Lucas MCH57; (Part No. 51655A).

**Pilot Lamps (2)**—Lucas 516 (Part No. 52224A).

**Rear Lamp**—Lucas 564 (Part No. 53432A) (Integral Reflector and Provision for Stop Light).

**Horn**—Lucas HF1441 (Part No. 70137A).

**Horn Push/Dipswitch**—Lucas 25SA (Part No. 31563A).

**Stop Switch (Optional)**—Lucas 22B (Part No. 31384A).

either case dynamo must be dismantled and repaired or replacement unit fitted.

**Note 1.** To check field-coil, connect a 6 volts DC supply, with ammeter, in series with coil. Reading should be approx. 2 amps. No reading indicates open circuit. To test for short circuit, connect mains test lamp to one end of coil and to yoke. If bulb lights a short circuit is present.

**Note 2.** Armature may be checked by voltage drop test or by a growler.

If dynamo is OK but still "no charge" when original connections restored, then check:

(3) **Automatic Voltage Control Unit.** (Voltage regulator and cutout combined structurally, but electrically separate).

**Note** before any adjustment is made to regulator setting, ensure that dynamo and battery are serviceable and all wiring connections are correct.

**Testing Unit.** (a) Connect negative lead of moving-coil voltmeter to regulator "A" terminal

and positive lead to earth. If voltmeter shows battery voltage, then wiring between battery and regulator (via switch) is OK. (b) Remake "earth" connection to "E" on regulator, disconnect battery negative lead and turn lighting switch to "Off". (c) Connect negative lead of moving coil voltmeter (0 to 10 volts) to "D" regulator terminal and positive lead to earth. (d) Start engine, slowly increase speed until needle "flicks" and steadies. Reading should be 7.6 to 8.0 volts (see A.V.C. Data Table).

If the reading is **incorrect**, adjust as in note 3. If reading **correct**, but still "no charge", then check electrical setting of cut-out: (a) Reconnect battery negative terminal. (b) Connect voltmeter between "D" on regulator and earth (negative and positive leads respectively). (c) Start engine, increase speed until cutout points close and note voltage at which this occurs. This should be 6.3 to 6.7 volts. To adjust, see note 4. If cutout does not operate or will not adjust, replace unit.

**Note 3.** Adjust electrical setting of regulator (with engine running at 1,500 to 2,000 r.p.m.) by turning adjusting screw a fraction at a time **clockwise** to raise setting and **anti-clockwise** to reduce.

**Note 4.** Adjust electrical setting of cut-out by turning adjusting screw a fraction at a time **clockwise** to raise the voltage setting or **anti-clockwise** to reduce.

Re-test after carrying out above adjustments. Both operations should be completed within 30 secs. to prevent false reading due to overheating.

(4) **Battery:** (Fitted positive to earth). Supplied "dry-charged". Fill cells to tops of separators, in one operation, with electrolyte (see Battery Data Table). Stand 1 hour. Battery is then 90 per cent charged. If desired, give freshening charge of 1.5 amp. up to 4 hours maximum.

**Maintenance** consists of (a) topping up to level of separators with distilled water, (b) keeping cell tops clean and dry, (c) examining for leaks, (d) smearing terminals with vaseline, (e) checking state of charge, using hydrometer and/or heavy discharge voltage tester (applied to each cell for 15 secs.) (See Battery Data Table). If dynamo polarity is reversed, repolarise by disconnecting dynamo "D" & "F" leads, connecting, for a few seconds, a wire between dynamo terminal "F" and the unearthed battery terminal (negative). Remove wire and reconnect leads.

**A.V.C. UNIT/BATTERY DATA TABLE**

A. Regulator Open Circuit Voltages Relative to Ambient Temperatures		B. Specific Gravity of Sulphuric Acid for Filling "Dry-Charged" Batteries		C. Relation between Battery State of Charge and (1) Electrolyte Specific Gravity and (2) Cell Voltage Readings			
Temperature	Voltage	Climates		State of Charge of Battery	Specific Gravity (Temperature under 90°F. over 90°F.)		Voltage Reading (12 amp. Load Test)
		Below 90°F(32°C)	Above 90°F(32°C)				
50°F or 10°C	7.7 to 8.1v.	1.270	1.210	Fully Charged	1.270-1.290	1.210-1.230	1.55-1.6v.
68°F or 20°C	7.6 to 8.0v.			Quarter Charged	1.190-1.210	1.130-1.150	1.45-1.5v.
86°F or 30°C	7.5 to 7.9v.	sp. gr.	sp. gr.	Fully Discharged	1.110-1.130	1.050-1.070	—
104°F or 40°C	7.4 to 7.8v.						

**Note 1.** Normal Recharge Rate (External D.C. Supply) for 12 amp./hour Battery is 1.5 volts.  
**Note 2.** The Electrolyte Specific Gravity of a Good Battery Should Not Vary More Than 25 Points, (1 Hydrometer Division) Between Cells.  
**Note 3.** High Sp. Gr. Reading and Low Cell Voltage Discharge Reading Indicates Hardened Plates or Acid Having Been Added to Cell.

The next servicing data sheet in this series will deal with the

**SIMPLEX DERAILEUR GEAR**

and will be included in the issue dated October 13, 1956.

Additional copies of these Service Sheets may be obtained by readers at 1s. each or 11s. a dozen.