

RE-GRINDING DETAILS FOR ALL TWINS

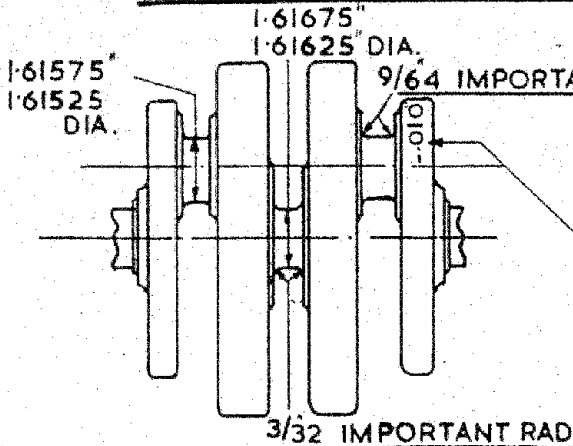

FIRST RE-GRIND

GRIND THE CRANKPINS TO 1.61575/
1.61525 DIA WITH 9/64 FACE RADIUS
GRIND THE CENTRE BEARING TO
1.61675/ 1.61625" DIA. WITH 3/32 FACE
RADIUS
STAMP-- O10" HERE.

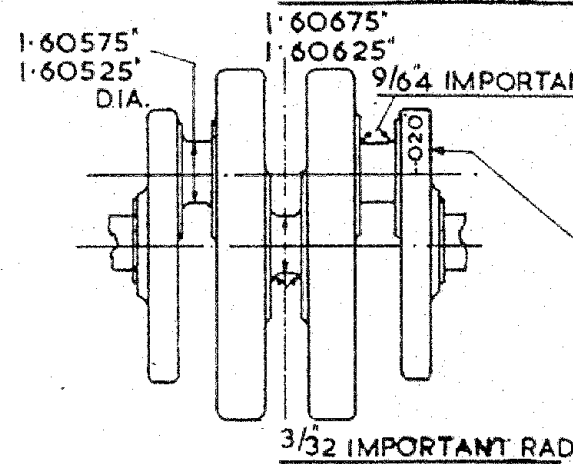

SECOND RE-GRIND

GRIND THE CRANKPINS TO 1.60575/
1.60525" DIA. WITH 9/64 FACE RADIUS
GRIND THE CENTRE BEARING TO
1.60675/ 1.60625" DIA. WITH 3/32 FACE
RADIUS.
STAMP -- O20" HERE.

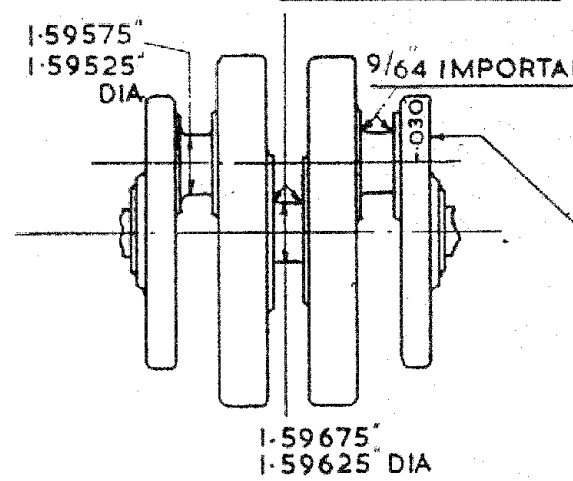

THIRD RE-GRIND

GRIND THE CRANKPINS TO 1.59575/
1.59525" DIA. WITH 9/64 FACE RADIUS
GRIND THE CENTRE BEARING TO
1.59675/ 1.59625" DIA. WITH 3/32 FACE
RADIUS.
STAMP-- O30" HERE

