

March, 1927.

C.S. TYPE.

THE

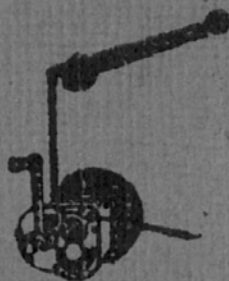

3-SPEED

STURMEY ARCHER
COUNTERSHAFT GEAR

FOR MOTOR CYCLES

STURMEY-ARCHER GEARS, LTD.,

LENTON, NOTTINGHAM, ENG.

TELEPHONE No. 4155.

TELEGRAMS: "TRIPLE, NOTTINGHAM."

SPECIAL FEATURES OF THE STURMEY-ARCHER COUNTERSHAFT GEAR.

THE GEARS are constantly in mesh for the full width of the teeth at all times and on all gears, the changes being effected by sliding dogs; there is no danger of stripping the teeth when changing gear.

The clutch is of the insert type, operated by a very light pressure on a handle-bar lever, and will be found ideal for solo riding and traffic work.

THE CLUTCH as illustrated was fitted up to the end of 1925, and consists of the main body (51) keyed to the gear box axle (12), and eight other plates, four of

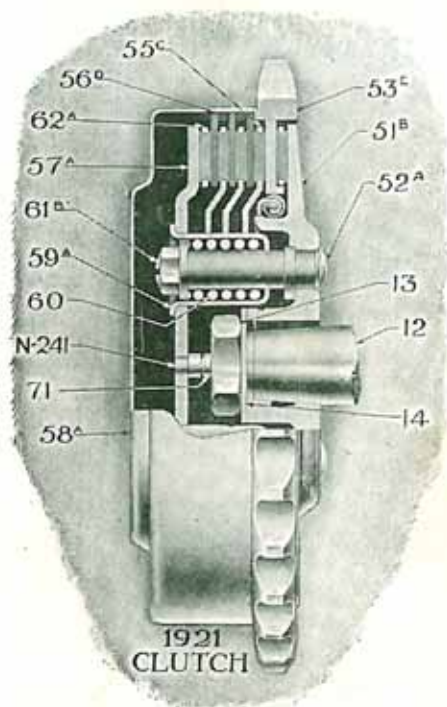

which (55 and 57) are coupled up to the main body by spring boxes (59) and studs (52).

The driving plates are the 30-tooth sprocket (53) the three plates (56); these are coupled to one another by tongues and grooves on the outer diameters. The sprocket runs on a ball bearing when free, so is frictionless.

The friction driving surfaces consist of "Ferodo" plugs inserted in plates (55) and (62). The result is a clutch which for sweetness of engagement and durability is unequalled.

The whole clutch may be readily dismantled by removing spring box screws.

NEWTON & SMYL
BRITISH MOTORCYCLE SPARES
164 MERTON HIGH STREET
LONDON SW19
01-540 1677

FROM 1926, 10 PITCH GEARS HAVE BEEN FITTED, ALSO A 34-TOOTH CLUTCH.

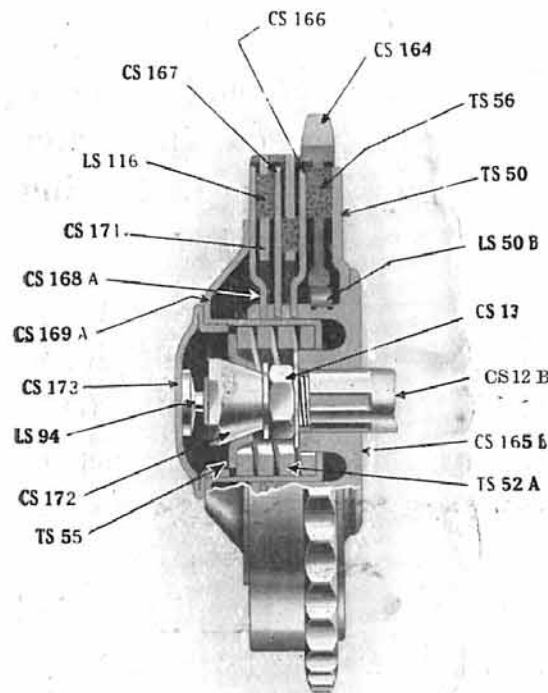

The construction of this Clutch will readily be followed from the illustration.

The Main Body (C.S. 165B) is splined to the Axle, and the four inner driven plates (C.S. 166-167-168A, also T.S. 50) are fixed by tongues and grooves to the body.

The Sprocket (C.S. 164), along with the two plates (C.S. 171), form the outer driving members carrying the friction plugs. The power is transmitted through the

medium of the plugs and the pressure exerted by the central spring.

The Sprocket, when free, runs on a roller bearing, and the whole Clutch may be taken to pieces by removing the outer cap (C.S. 173) and the taper nut (C.S. 172).

CHANGING GEAR.

When changing gear it is advisable to declutch, but not absolutely necessary, as the gear may be changed by lifting the exhaust valve momentarily when operating the gear lever. When declutching it is advisable to completely declutch instead of attempting to change with the clutch partly gripping, especially when changing down from top to middle, or middle to low.

TO ADJUST THE CLUTCH, the wire stop screw should be screwed up until there is about $\frac{3}{8}$ in. to $\frac{1}{2}$ in. of idle movement in the clutch worm lever. In extreme cases it may be necessary to loosen the clutch worm lever from the worm to find a more convenient operating position. The only parts of the clutch liable to wear are the friction plates, which are easily replaced. The clutch should be adjusted immediately any sign of slipping is felt. Should oil get on the clutch, as may occur when newly assembled, this will cause slipping; to overcome, inject petrol. A sure sign of slipping is given by the clutch becoming very warm whilst driving. In the case of a combined chain and belt drive the belt should be suspected of slipping before interfering with the clutch.

When fitting up the control wire for the clutch, ease off the bends as much as possible to ensure long life and easy movement of the wire.

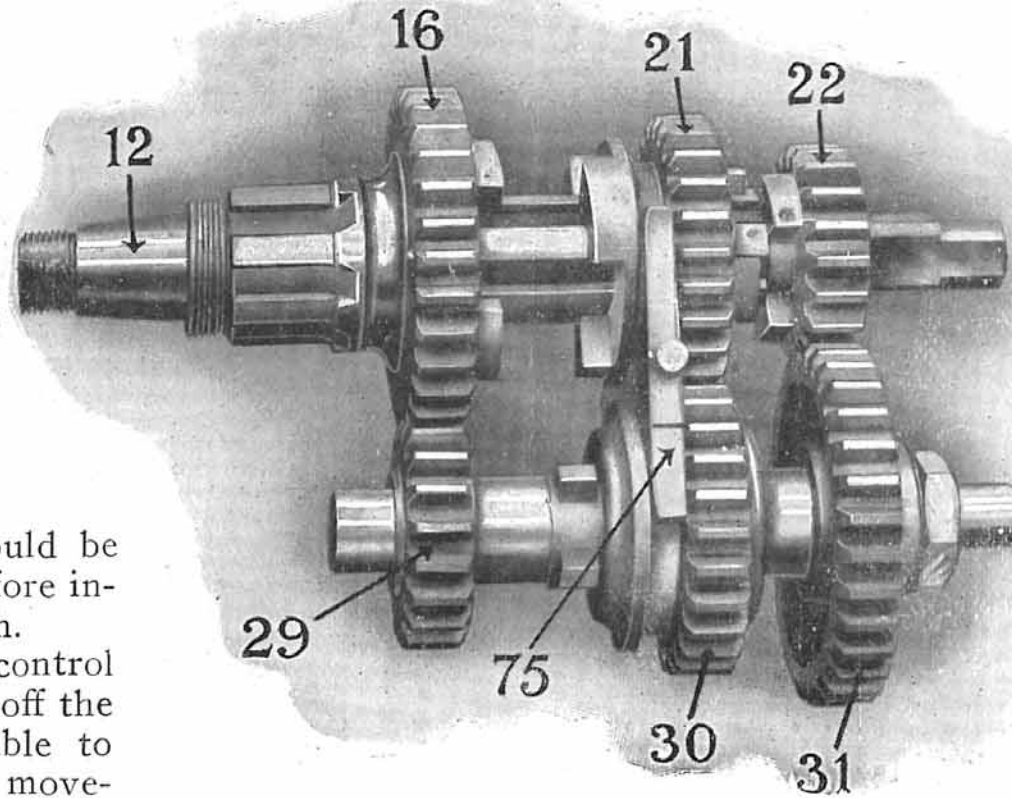

GEARS. The clutch body (51) is keyed on the taper end of the main axle (12), the central portion of which is formed with six keyways cut from the solid metal. The central pinion (21) has corresponding keyways, and consequently is always rotated with the axle, although free to slide longitudinally. The gear wheel (16), to which the pulley is fixed, revolves freely on the axle, as does also the small pinion (22).

The layshaft (29) has keyed upon it at one end the gear wheel (31), and is also formed with four clutch dogs in the centre, into which may be engaged at will a corresponding set of clutch dogs in the sliding pinion (30).

The two sliding pinions are connected by a forked plate (75), and are so operated simultaneously. The action is as follows:

HIGH GEAR.—The sliding pinions are moved to the left, so that the clutch teeth on pinion (21) will engage corresponding clutch teeth on gear wheel (16), thus locking the latter to the axle and giving a solid top gear drive. A recess formed within the pinion (30) ensures that the latter is free from driving engagement with the layshaft.

MIDDLE GEAR.—The sliding pinions are moved to the central position, releasing the high gear dog clutch and permitting the clutch dogs on the layshaft (29) to engage with the internal clutch teeth in the layshaft sliding pinion (30). The drive is then transmitted from the axle through the sliding pinions to the layshaft, thence by the layshaft pinion (29) to the main gear wheel (16).

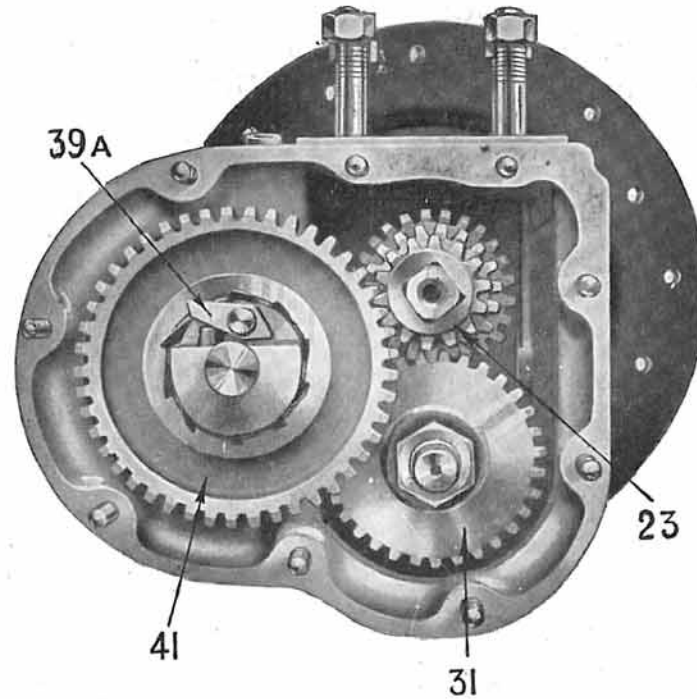

Internal Mechanism of 3-Speed.

LOW GEAR.—The sliding pinions are moved to the right, engaging the right hand clutch on the axle sliding pinion with the clutch teeth on low gear pinion (22), and releasing the clutch dogs on the layshaft (29) from the layshaft sliding pinion (30). The drive is effected through the pinion (22) to the layshaft gear wheel (31), and thence to the main gear wheel (16) by the layshaft pinion (29).

In all three gears each pair of pinions is continuously in mesh, there is no risk of chipping the gear teeth.

Both the layshaft and the main gear wheel (16) revolve on ball-bearings, reducing friction to a minimum.

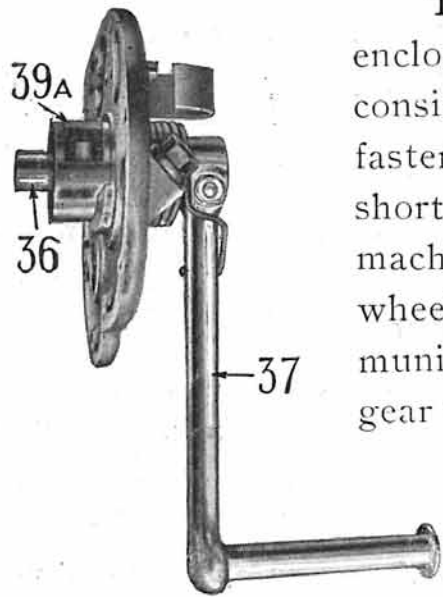

Kick Starter.

The **KICK STARTER**, enclosed in the gear box, consists of a crank lever (37) fastened by a taper cotter to a short shaft (36), which is machined out to receive a free wheel pawl (39). This communicates movement to a large gear wheel (41) in mesh with a small pinion (23), mounted on a squared portion of the main axle. When the return spring brings the crank back to its normal

vertical position, a projection on the free wheel pawl comes into engagement with a fixed cam mounted in the gear box cover and positively depresses the pawl out of action.

The **GEAR CONTROL** is separate from the gear box and is adjustable to suit any machine. The forward position is low gear, then neutral (for starting-up), middle and high gear.

GEAR ADJUSTMENT.—It is important to see that the gear control is kept properly adjusted, and this should be tested occasionally to see that it is correct.

Before proceeding to adjust the control see that the nut on the rocking shaft behind the box is thoroughly tight.

The adjustment of the gear is effected by removing the pin from the top connection on the end of the control rod, and giving the connection one turn, or half a turn on the thread up or down to lengthen or shorten the control rod as required. When the gear is properly adjusted the control lever should move an equal amount either side of the neutral notch without engaging either the middle or low gear, finally checking by pin in top connection, being just free to slide when in high gear.



STARTING.—Place the gear lever in the neutral position with the clutch in engagement, start the engine by the kick starter, then declutch before engaging the low gear, after which the clutch may be re-engaged and other gears operated as desired.

Don't forget to declutch before moving gear lever from neutral position. If the gears are engaged **from rest** without having previously declutched, the machine will leap forward and possibly lead to serious accident.

LUBRICATION.—Use Speedwell “Crimsangere Light,” Wakefield “Castrolase Light,” or Vacuum “Mobilubricant Soft,” specially prepared for Sturmey-Archer Gearboxes. Facilitate gear changing and do not leak. “Crimsangere” and “Castrolase” are supplied in 1lb. tubes. Charge with $\frac{1}{2}$ lb., and recharge with $\frac{1}{4}$ lb. about every 1,000 to 1,500 miles. Add about 3 tablespoonsful of engine oil to the “Crimsangere” and “Mobilubricant Soft.”

It is very important to see that these instructions are carefully observed. No harm is done by an additional charge, but on the other hand we find that a large percentage of gear trouble can be directly attributed to insufficient lubrication or by using a lubricant which is not suitable.

It is not advisable to use thick grease, as it may prevent the free operation of the kick starter pawl.

The various joints in the gear changing lever mechanism should be kept oiled regularly to ensure freedom of action. Inject a little vaseline or grease between the index and quadrant plate CS110 and CS111.

DO NOT lubricate the clutch, as this is designed to run dry.

LIST OF AVAILABLE GEARS.

12 pitch Gears supplied up to the end of 1925.					10 pitch Gears as supplied from 1926 onwards.				
Top.	Standard Ratio.		Close Ratio.		Top.	Standard Ratio.		Close Ratio.	
	Middle	Low	Middle	Low		Middle	Low	Middle	Low
1	1.63	2.66	1.28	1.63	1	1.47	2.647	1.33	2.16
3	4.9	8	3.82	4.9	3	4.41	7.94	4	6.48
3.25	5.3	8.65	4.18	5.3	3.25	4.78	8.60	4.33	7.02
3.5	5.7	9.3	4.45	5.7	3.5	5.14	9.26	4.66	7.56
3.75	6.13	10	4.82	6.13	3.75	5.51	9.92	5	8.10
4	6.53	10.65	5.09	6.53	4	5.88	10.59	5.33	8.64
4.25	6.93	11.31	5.4	6.93	4.25	6.25	11.25	5.66	9.18
4.5	7.34	11.98	5.73	7.34	4.5	6.61	11.91	6	9.72
4.75	7.75	12.64	6.04	7.75	4.75	6.98	12.57	6.33	10.26
5	8.16	13.31	6.36	8.16	5	7.35	13.23	6.66	10.80
5.25	8.56	14	6.73	8.56	5.25	7.72	13.89	7	11.34
5.5	8.96	14.65	7.10	8.96	5.5	8.08	14.55	7.33	11.88
5.75	9.38	15.3	7.46	9.38	5.75	8.45	15.21	7.66	12.42
6	9.78	16	7.83	9.78	6	8.82	15.88	8	12.96

PARTICULARS OF GEARS.

Our Standard gear box is supplied with a Clutch suitable for a 600 c.c. single or a 1,000 c.c. twin engine.

CHAIN-CUM-BELT.

Engine chain line, $3\frac{7}{16}$ in.

Belt line, $2\frac{3}{8}$ in.

Belt pulley, 8 in. dia. for 1 in. belt.

ALL CHAIN.

Engine chain line, $3\frac{7}{16}$ in.

Rear chain line, $2\frac{7}{8}$ in.

Clutch sprocket, 34T, $\frac{5}{8}$ in. pitch x $\frac{3}{8}$ in. or $\frac{1}{4}$ in. wide.

Back sprocket, 19T, $\frac{5}{8}$ in. pitch x $\frac{3}{8}$ in. or $\frac{1}{4}$ in. wide.

Can also be supplied with 30T Clutch sprocket and 17T rear sprocket.

Additional rear sprockets available:—15, 16, 18, 22 and 24T.

PARTICULARS REQUIRED WHEN ORDERING GEARS.

Make and c.c. of engine.

Type of drive:—All chain.

” ” ” Chain-cum-belt.

Number of teeth on sprockets with pitch and width of chains.

Type of control:—This Gear can only be supplied with disc control on seat tube (dia. of tube).

Dia. of handlebar.

FORMULA FOR FINDING THE TOP GEAR RATIO.

*Diameter of Belt Drum \times $\frac{\text{No. of Teeth on Clutch Sprocket}}{\text{Diameter of Gear Pulley} \times \text{No. of Teeth on Engine Sprocket}}$ Top Gear Ratio.

Example $\frac{20}{8} \times \frac{30}{15} = \frac{5}{2} \times \frac{2}{1} = \frac{10}{1} = 5$ to 1 Top Gear.

For Middle and Low Gear Ratios see table on previous page.

*For All Chain Drive insert No. of Teeth of Back Sprocket and Gear Sprocket.

TO DISMANTLE THE GEAR BOX.

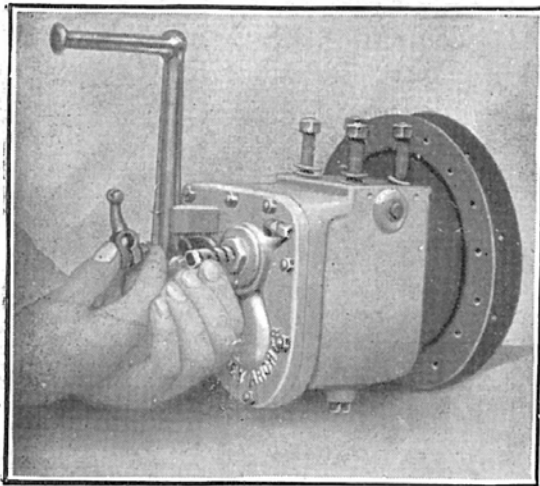

Taking off Clutch Control and operating worm.

The first operation is to remove the belt and Bowden control to the clutch. This can easily be done by slackening off the adjustment, when the nipple can be slipped out of the small operating arm. Disconnect the gear control rod at the upper jaw end, by removing the pin, then, by undo-

ing the four nuts which secure the gear box to the frame of the motor cycle and removing the spring washers, the whole gear box can be lifted clear.

The next operation is to remove the clutch lever from the clutch-actuating worm. This is done by slackening off the small set screw at the bottom, when this lever can be drawn off the worm. The latter can then be removed by unscrewing it out of the clutch nut.

Now remove the gear box cover by undoing the nine nuts which hold this cover to the casing. Care should be taken when this is removed that the small spring washers which will be found in the recesses below the nuts are not lost. Do not in any circumstances use a screw-driver or similar tool to part the gear box cover from the gear box, or this will fail to retain the oil

in the gear box when it is re-assembled, owing to the faces being damaged.

Next take hold of the kick-starter crank and ease the cover off the studs: this will expose the complete interior to view.

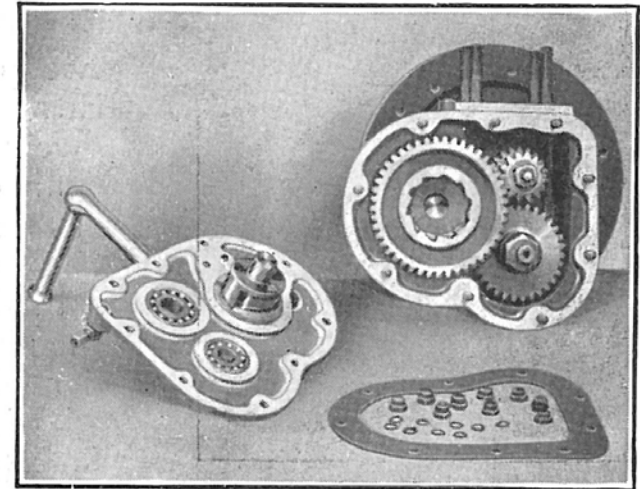

The next item to be removed is the double spring washer which will be found on the end of the layshaft.

Now remove the large gear wheel off the kick-starter axle bush, the smaller wheel, which is on a square on the main shaft of the gear box, can now be slipped off, as also can the gear wheel, which will be found behind that.

Note should be taken while these gear wheels are being removed from the shaft of the exact position which they fit, otherwise some difficulty may occur when the gear box is re-assembled. It will be seen that the second wheel to be taken off has three dogs, which engage with the dogs on a sliding gear wheel immediately behind. Before proceeding further with the dismantling of the gear box it would be advisable to take out the clutch operating rod from the centre of the main shaft.

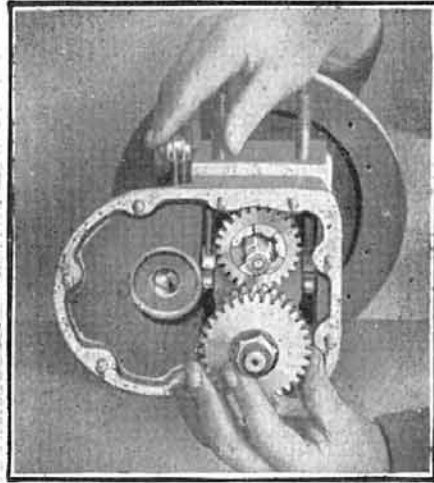

the bolt through the rocking fork actuating the gear fork can be removed by undoing the nut, which will be found at the rear of the gear box, and withdrawing the bolt from the opposite side. The actuating lever should also be taken out of the socket in which it operates. The whole of the gears, complete with the fork, can then be removed as before. The gear wheels and layshaft can now be withdrawn bodily, as the rocking fork inside the box is free to swing forward far enough to clear the pins on the gear operating plate. All that will be left in the gear box are the mainshaft and the gear wheel which is attached to the belt pulley. There is practically no need further to dismantle the inside of the gear box, and all that remains now is thoroughly to clean it before a complete examination of all the parts is made.

We can now turn our attention to the clutch. This is attached to the sprocket which takes the chain drive

With regard to the removal of the remainder of the gears, there are two different methods. Either the gear-changing mechanism can be disconnected from the lever at one of the toggle joints (by simply removing the split pin and drawing out the pin), and the remainder of the gear wheels withdrawn owing to the fork being free to move in any direction, or else

from the engine. The first operation in dismantling the clutch is to detach the dust cover which is sprung over an extension of the sprocket. Under this will be found six screws which may readily be undone, either with a screwdriver or a box spanner. Under these screws will be found the clutch springs. Before the last screw has been removed it is advisable to stand the gear box on end, so that the parts of the clutch do not fall apart before note has been taken of the order in which the plates are assembled.

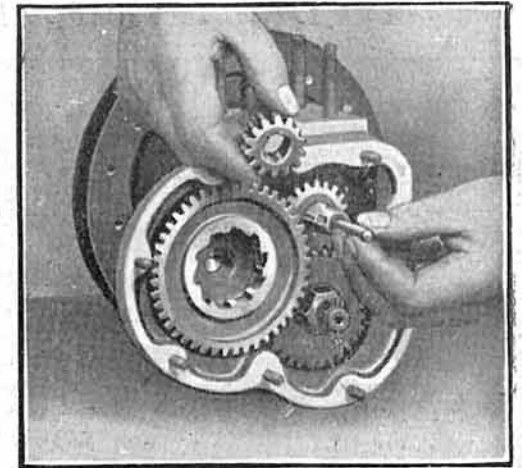

The outside plate carries with it the six clutch spring boxes, and immediately under this plate will be found a Ferodo ring. Below this will be found another steel plate, with projections on the edges which engage with slots in a flange attached to the sprocket, and under this again another Ferodo ring and then a steel plate, which is held in position by holes into which the spring boxes fit. Under this is another ring and a plate attached to the sprocket, and so on, until there are no more steel plates. The sprocket can now be removed. Finally, behind the sprocket will be found the last Ferodo ring, which fits against a steel flange which is part of the clutch body.

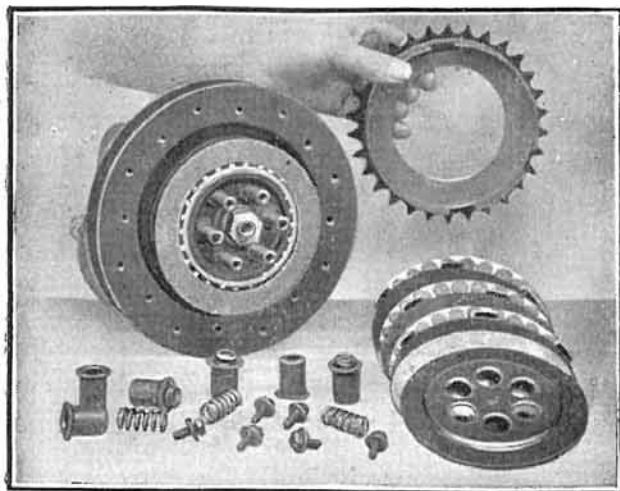

To assemble the clutch easily, it would be well to fix the square end of the shaft in a vice, if possible, with the gearbox standing on its end. When the ball cage has been replaced the clutch can be built up, care being taken to start

with a Ferodo ring next to the clutch body, then the sprocket, then another ring, then a plate with holes in the centre for connecting to spring boxes, then another ring, and so on. When the plates have all been put on, the spring boxes should be placed in position. If the plates which connect on to these have been placed as near as possible, so that the holes are over the pins on the clutch body, the spring boxes will easily slip into place. The springs can now be put into the boxes and the six screws may be replaced. To fix the screws some pressure will be found necessary, and the axle must be held to prevent the clutch from rotating until the screws are firmly home. Finally, the dust cover is replaced.

Having finished the clutch we can now return to the gears and re-assemble these. The replacing of the layshaft, the sliding gear plate, the fork and the sliding pinion will require a little patience, but should not take more than a few minutes. Care should be taken that

the sliding pinion is placed on the mainshaft with the collar towards the pulley. When this has been done the low gear pinion can be slipped on with the dogs towards the pulley and, finally, the starter pinion. The clutch-operating rod can also be slipped down the centre of the mainshaft.

The edges of the gearbox and that part of the cover which comes in contact with it should now be finally wiped to remove the slightest trace of dirt or foreign matter, then the paper joint smeared with gold size, should be placed in position. Lastly, and this is highly important, the double spring washer should be replaced on the layshaft (lower shaft) and the cover slipped on. The nine small washers should next be placed on the studs and the nuts slipped on and screwed up. It is advisable to do all these nuts to finger pressure first before giving any one a final clinch up. The clutch worm can now be replaced in its thread in the clutch nut, and the small lever placed on over this. The worm should be screwed in through the nut, so that it just presses on the clutch rod, and the lever should be gripped on this approximately in a vertical position. Care should be taken, if this lever is cranked, that it is put on in the right way, *i.e.*, so that the wire has a direct pull upon it. Before use, the gear box must be lubricated as shown on page 6.

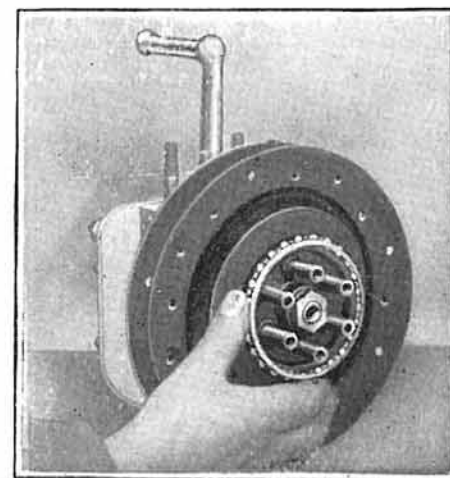

STURMEY-ARCHER 3-SPEED COUNTERSHAFT GEAR WITH FIBRE RING CLUTCH.
 SEE PAGE 1 FOR ILLUSTRATION OF PRESENT PATTERN INSERT CLUTCH.

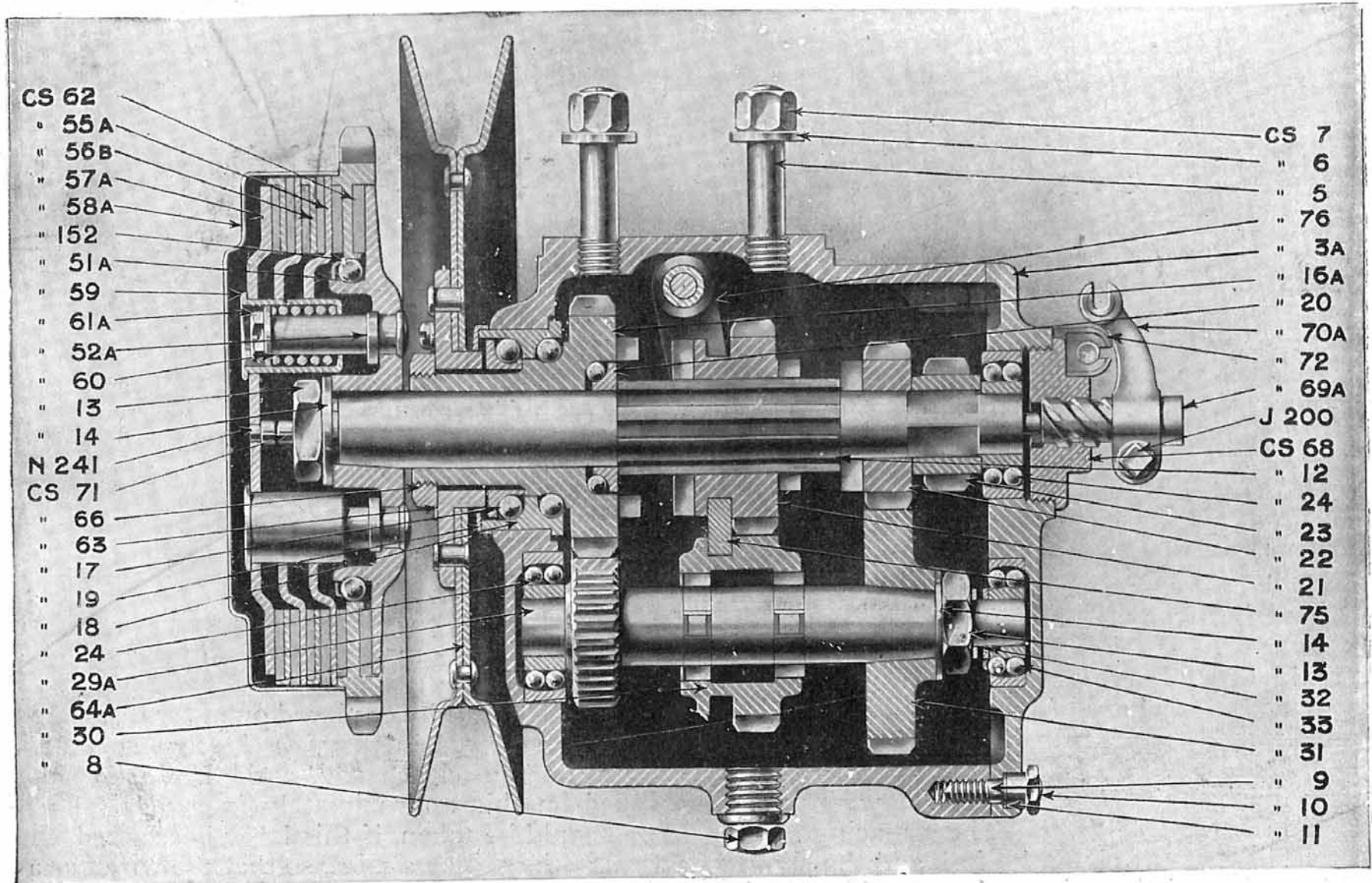

A SECTIONAL VIEW OF THE STURMEY-ARCHER 3-SPEED COUNTERSHAFT GEAR.

3-SPEED COUNTERSHAFT GEAR PARTS.

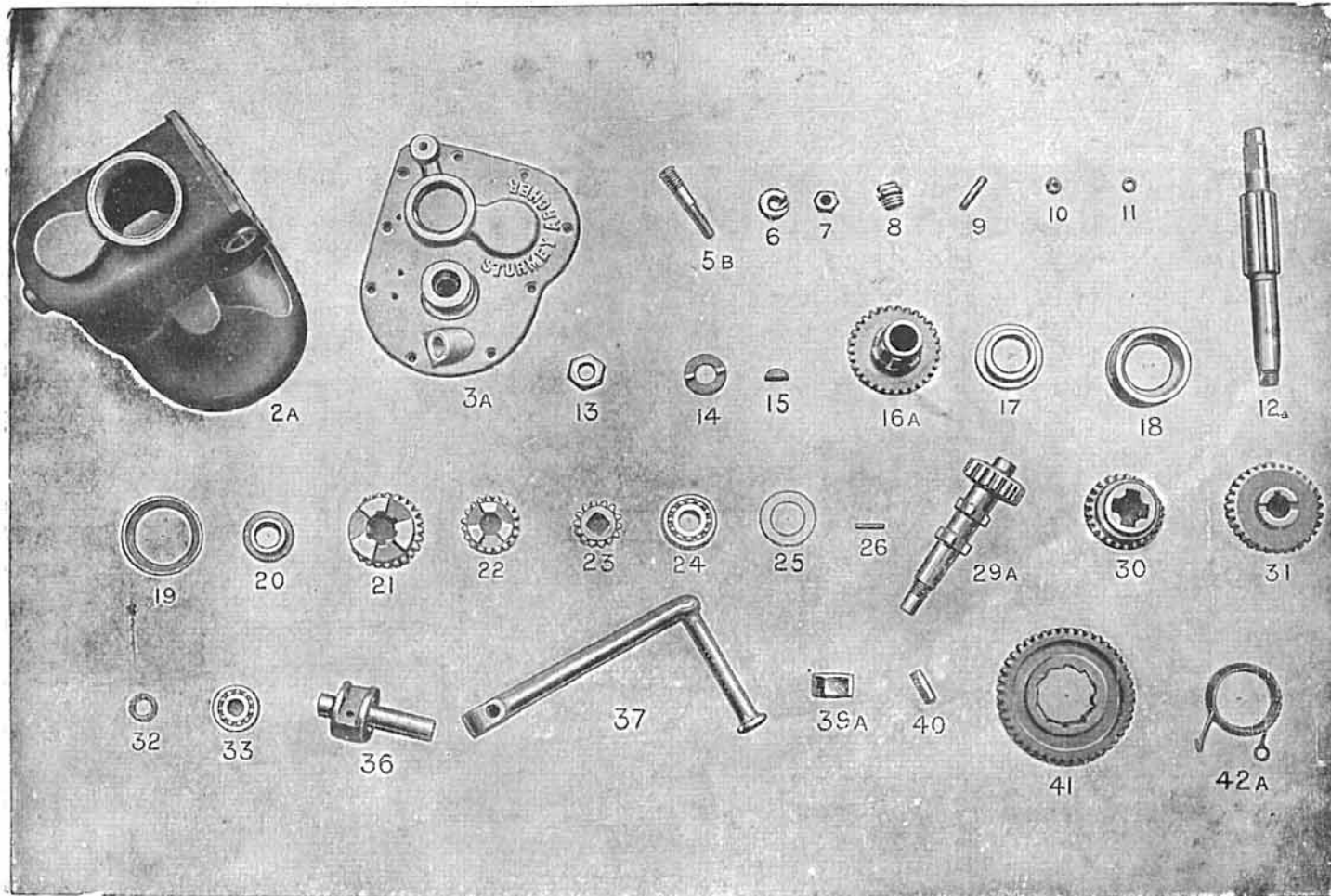

To avoid mistakes when ordering spare parts quote the number and preceding letters.

		£	s.	d.
CS 2a	Gearbox	2	17	6
CS 3a	" Cover	0	0	5
CS 5b	" Stud	0	0	2
CS 6	" Spring Washer	0	0	3
CS 7	" Nut (also used for CS112)	0	0	8
CS 7a	" Gearbox Nut, domed and plated	0	0	9
CS 8	" Oil Plug	0	0	3
CS 9	" Cover Stud	0	0	2
CS10	" Cover Nut	0	0	6
CS11	" Spring Washer, Set of 9	0	13	6
CS12	Axle	0	0	5
CS13	" Nut	0	0	1
CS14	" Nut Lock Washer	0	0	3
CS15	" Key, 3/4 in. wide	0	0	3
CS15a	" Key, 3/8 in. wide	0	0	3
CS16	Main Gear Wheel, screwed	0	16	0
CS16a	Main Gear Wheel, splined with Ball Race Axle Bearing	0	16	0
CS16b	Main Gear Wheel, splined with Plain Axle Bearing and Loose Cones	0	16	0
CS17	Left Hand Cone	0	2	6
CS17a	L.H. & R.H. Cone (used on CS16b)	0	2	6
CS18	Left Hand Ball Cup	0	5	0
CS19	" Dust Cap	0	0	3
CS20	Axle Cone	0	1	9
CS20a	" Thrust Washer	0	1	6
CS21	" Sliding Pinion	0	10	0
CS22	Low Gear Axle Pinion	0	6	0
CS23	Kick Starter Pinion	0	3	4
CS24	R.L. 5 Skefko Bearing	0	8	9
CS25	Left Hand Ball Cup Adj. Washer	0	0	1
CS26	Gearbox Stud Dowel	0	0	1
CS29a	Layshaft	0	17	0
CS30	" Sliding Pinion	0	8	6
CS31	" Low Gear Wheel	0	7	0
CS32	" Spring Washer	0	0	2
CS33	R.L. 4 Skefko Bearing	0	8	0
CS34	Layshaft Axle only, without Pinion	0	12	0
CS35	Layshaft Pinion	0	5	0
CS36	Kick Starter Axle	0	8	6
CS37	" Crank	0	12	6
CS39a	" Pawl	0	1	3
CS40	" Pawl Pin	0	0	3
CS41	" Wheel	0	10	6
CS42a	" Return Spring	0	1	0
TS58	" " " " " " " " " " (enclosed type, not illustrated)	0	1	0
TS58a	Washer to make TS58 adaptable to box	0	0	8
TS24	Return Spring Cap (not illustrated)	0	0	9

3-SPEED COUNTERSHAFT GEAR CLUTCH PARTS.

To avoid mistakes when ordering spare parts quote the number and preceding letters.

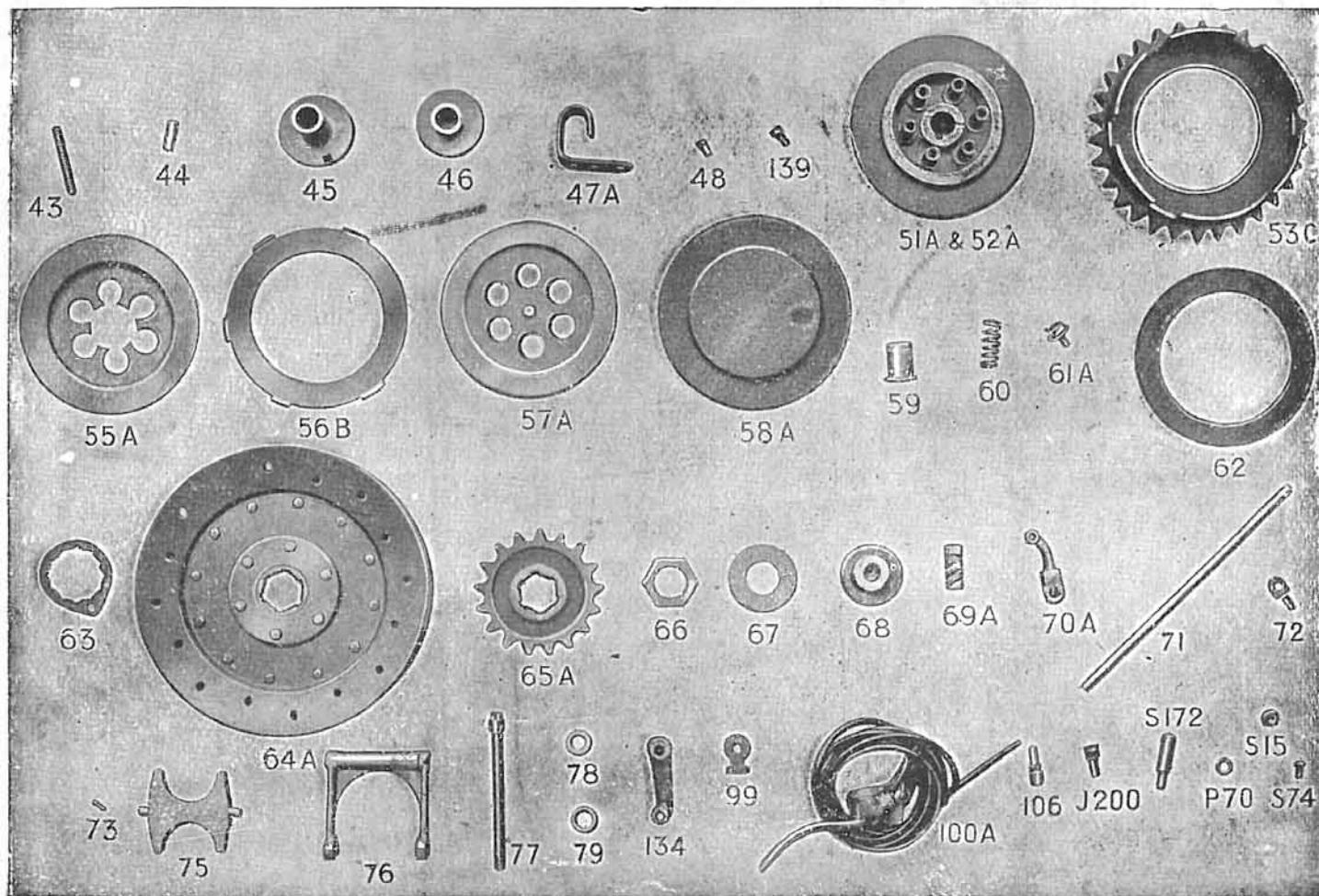

Part No.	Description	£	s.	d.
CS43	Kick Starter Pawl Spring	0	0	1
CS44	" " Spring Plunger	0	0	3
CS45	" " Cam Bush	0	5	0
CS46	" " Inner Bush	0	4	6
CS47a	" " Stop Spring	0	0	7
CS48	" " Cam Rivet	0	0	1
CS51a	Clutch Body, complete	1	2	6
CS52	Clutch Ball Cage	0	1	0
	(not illustrated)			
CS52a	" Rod Pins, each	0	0	10
CS53	" Sprocket	1	6	0

Part No.	Description	£	s.	d.
CS55a	Clutch Centre Plate	0	2	0
CS56b	" Friction Plate	0	1	4
CS57a	" Outer Plate	0	2	6
CS58a	" Cover Plate	0	2	6
CS59	" Spring Box	0	0	4
CS60	" Spring	0	0	2
CS61a	" Spring Screw	0	0	2
CS62	Clutch 'Halo' Fibre Ring	0	2	0
	(62a Plug Ring can be used as an alternative)			
CS63	Pulley Locking Plate	0	0	5
CS64	Pulley	0	15	0

Part No.	Description	£	s.	d.
CS65a	Axle Sprocket 17T & 19T	0	7	6
CS66	Pulley or Axle Sprocket Lock Nut	0	0	9
CS67	R.H. Adj. Washer	0	0	1
CS68	Clutch Nut	0	5	0
CS69a	" Worm	0	1	9
CS70a	" Worm Lever	0	2	6
CS71	" Rod	0	0	10
CS72	Wire Stop Stud	0	1	0
CS73	" Nipple, per pair	0	0	1
CS75	Sliding Gear Plate	0	2	6
CS76	" Fork	0	6	6
CS77	Rocking Shaft	0	1	3
CS78	" Bush	0	0	4
CS79	" Lever Bush	0	0	4
CS99	" Lock Washer	0	0	2
CS100a	Clutch Control Complete	12	0	0
CS100b	" " less wires & stop	8	0	0
CS106	Bowden Wire-Stop	0	0	9
CS134	Rocking Shaft Lever	0	3	0
CS139	Return Spring Screw for Kick Starter	0	0	1
CSJ200	Clutch Worm Lever Bolt	0	0	1
CSS172	Cotter Pin for K.S. Crank	0	0	2
CSS15	" Nut	0	0	1
CSP70	" Washer, per doz.	0	0	4
CSS74	Pulley Locking Plate Screw (Actual Symbol No. S35)	0	0	1
CSS25	Nut for Rocking Shaft CS77 (not illustrated)	0	0	2
CSN241	Stud for Centre of Clutch Outer Plate 57a	0	0	1
6 Feet	Clutch inner wire	0	0	8
5 "	8in. Clutch Outer Bowden Cable	0	2	8
CSX90	Handlebar Clutch Control Clip Screw (not illustrated)	0	0	1

OLD TYPE GEAR CONTROL PARTS (Not Illustrated).

FIXED ON BOX.

Part No.	Description	£	s.	d.
CS80	Rocking Shaft Lever	0	3	0
CS81	Gear Quadrant and Stud	0	5	0
CS82	Plunger Lever	0	8	0
CS83	Long Gear Lever with Knob complete	0	6	0
CS85	Short Gear Lever	0	5	0
CS86	" " Swivel	0	0	9
CS87	Female Gear Connection	0	0	10
CS88	Male Gear Connection	0	0	10
CS93	Quadrant Plate Bolt	0	0	6
CSS25	" " Nut	0	0	2
CSJ59	Plunger for Lever No. 82	0	0	3
CSJ60	" Spring for Lever No. 82	0	0	2

3-SPEED COUNTERSHAFT GEAR CONTROL PARTS.

To avoid mistakes when ordering spare parts quote the number and preceding letters.

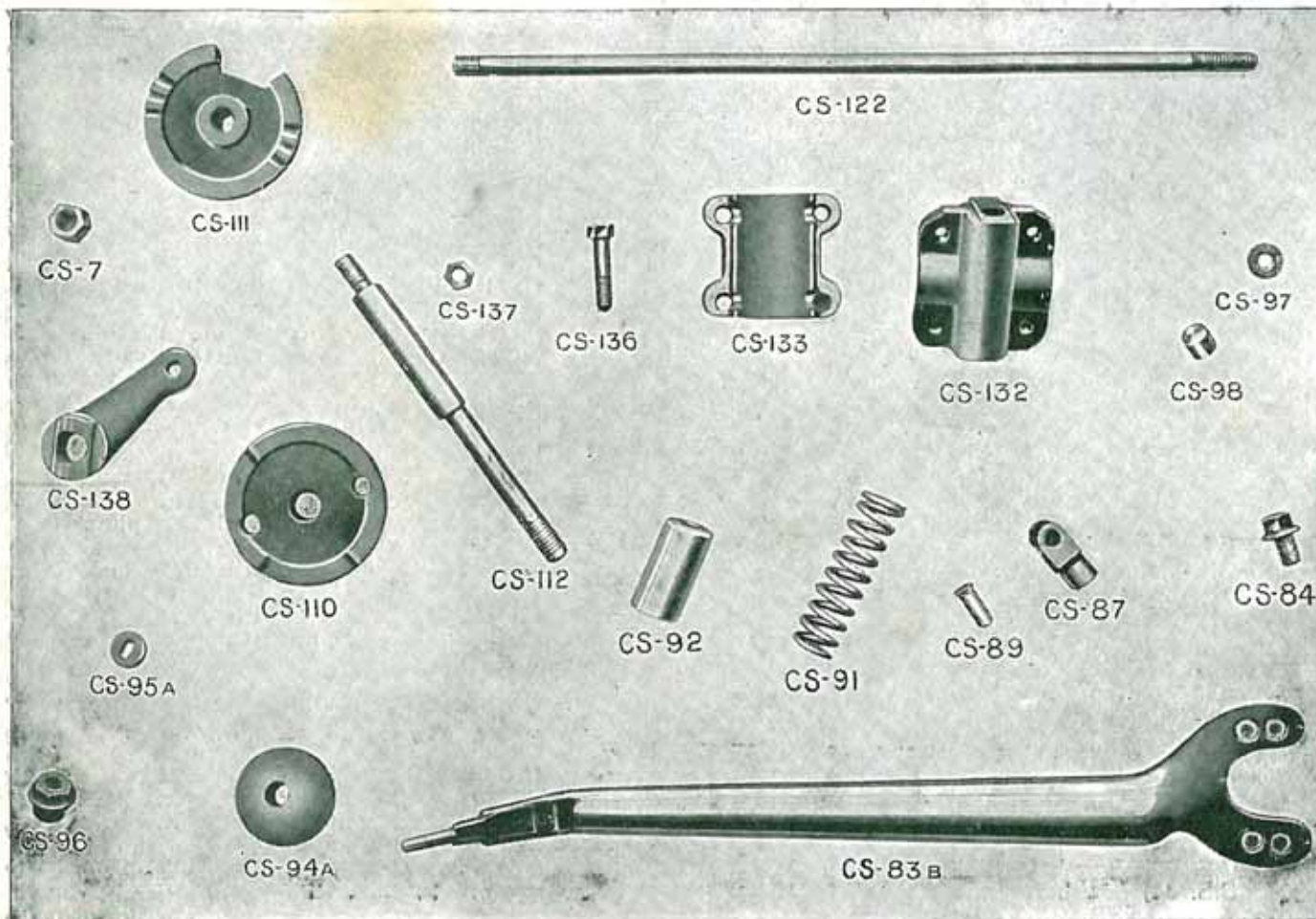

1921 CLUTCH PARTS.

(Illustrated on page 1).

	£	s.	d.
CS 55c Plugged Centre Plate ...	0	3	4
CS 56d Clutch Friction Plate ...	0	1	4
CS 62a Plug Ring ...	0	2	9
Clutch Friction Plugs, per doz	0	1	0

GEAR CONTROL.

CS 83b Long Gear Lever and Knob	0	6	0
CS 84 " " " Bolt ...	0	0	2
CS 87 Gear Connection ...	0	0	10
CS 89 " " Pin ...	0	0	2
CS 91 Quadrant "Relief Spring ...	0	0	5
CS 92 " " " Box ...	0	0	5
CS 94a Gear "Lever" Knob " ...	0	0	9
CS 95a " " " Washer ...	0	0	1
CS 96 Quadrant Spring Nut ...	0	0	6
CS 97 Gear Connection Washer ...	0	0	1
CS 98 Collar for Quadrant Knob...	0	0	2
CS110 Index Plate ...	0	6	6
CS111 Quadrant ...	0	5	0
CS112 " Stud ...	0	1	6
CS122 Gear Control Rod ...	0	1	0
CS132 Clip for Control ...	0	3	9
CS133 Cover for Control Clip ...	0	2	6
CS136 Screw for Quadrant Clip ...	0	0	4
CS137 Gear Connection Lock Nut...	0	0	1
CS138 Short Gear Lever (Disc Cont.)	0	5	0
CS151 Grover Spring Washer for Stud Quadrant (not illustrated) ...	0	0	1

GEAR CONTROL COMPLETE ... 1 15 0

SPEEDWELL CRIMSANGERE
lubricant specially prepared for
Sturmey-Archer Gears, in 1-lb.
tubes (see page 6) each ... 0 1 10

SPECIAL PARTS USED ON 1926 CS. GEARBOXES (10 PITCH).

To

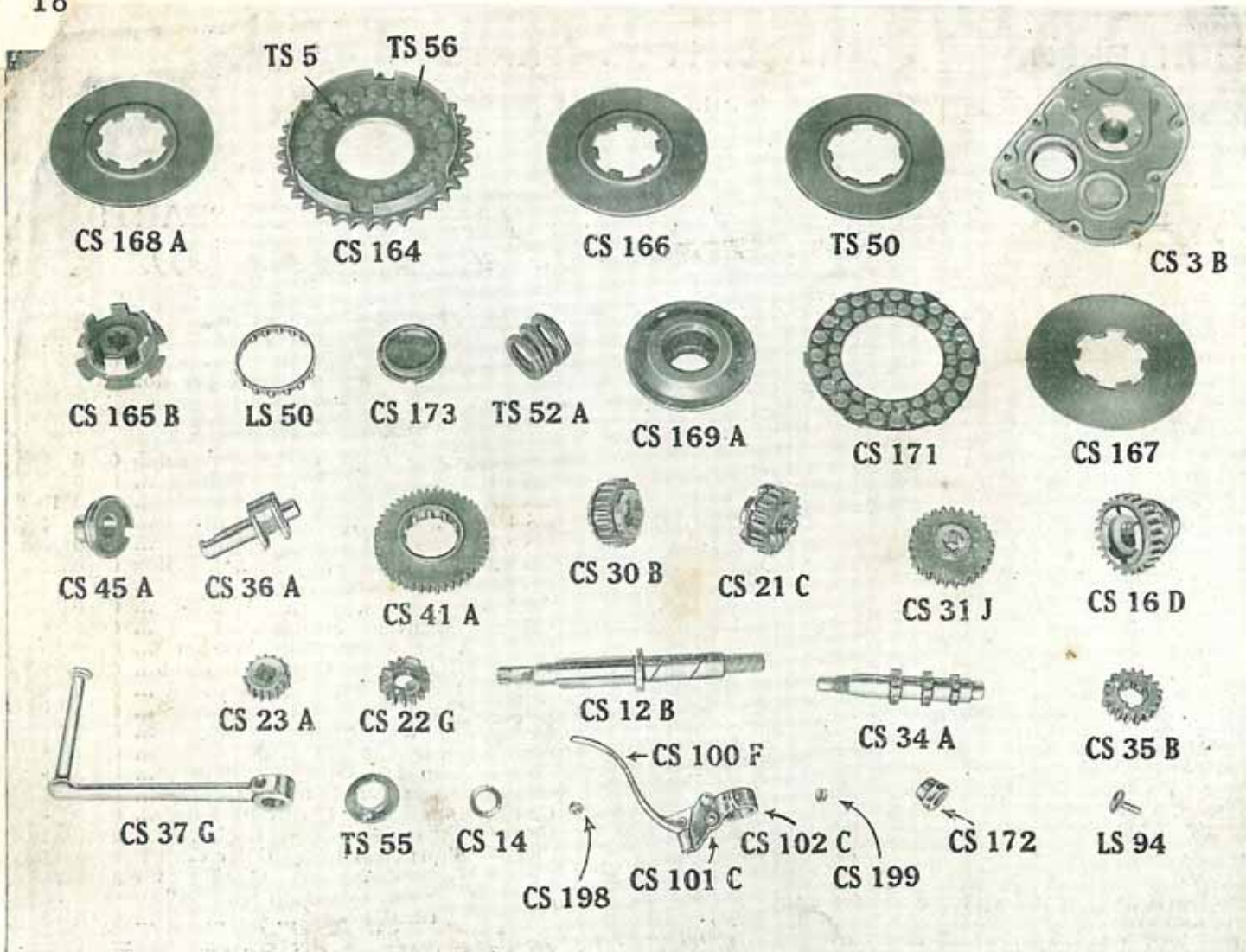

	£	s.	d.
C.S. 2a Gearbox Shell
C.S. 3b Gearbox Cover	2	17	6
C.S. 12b Main Axle	0	13	6
C.S. 16d Main Gear Wheel 25T	0	16	0
C.S. 17a L.H. or R.H. Cone for Main Gear Wheel	0	2	6
C.S. 21c Main Axle Sliding Pinion 21T	0	10	0
C.S. 22g Low Gear Axle Pinion 15T	0	6	0

C.S. 30b Layshaft Sliding Pinion 21T	0	8	6
C.S. 31j Layshaft Low Gear Wheel, 27T	0	7	0
C.S. 35b Layshaft Pinion (K.E.) 17T	0	5	0
C.S. 36a K.S. Axle	0	8	6
C.S. 37g Crank	0	12	6
C.S. 45a K.S. Cam Bush	0	5	0
C.S. 23a K.S. Pinion	0	3	4
C.S. 41a K.S. Wheel	0	10	6

FOR CLOSE RATIO GEARS
the following are substituted:

C.S. 21c Close Ratio Axle Sliding Pinion, 22T	0	10	0
C.S. 30b Close Ratio Layshaft Sliding Pinion 20T	0	8	0
C.S. 22g Close Ratio Low Gear Pinion 17T	0	6	0
C.S. 31j Close Ratio Low Gear Wheel 25T	0	7	0

34T HEAVYWEIGHT CLUTCH

	£	s.	d.
LS 50 Roller Cage (less rollers)	0	2	0
LS 50 " " (complete)	0	4	9
LS 50a " " Plate	0	0	3
LS 50b Roller	0	0	2
LS 50c Rivet (set of 8)	0	0	2
LS 82b Clutch Rod	0	0	10
LS 94 Thrust Pin	0	0	10
LS116 Friction Plug, $\frac{5}{8}$ in. dia.	0	1	0
LS116a " " $\frac{1}{2}$ in. " "	0	1	0
LS117 Adjuster Nut Packing Washer	0	0	1
TS 55 Clutch Spring Collar (fits over CS172)	0	0	6
CS 13 Axle Nut	0	0	5
CS 14 " Nut Lock Washer	0	0	1
CS 15a " Key, $\frac{3}{8}$ in.	0	0	3
CS164 Clutch Sprocket (34T), with corks	1	6	0
CS164 " " with fibre plugs	1	8	0
CS165b " Centre	0	12	0
CS166 " Centre Plate (Dished)	0	2	6
CS167 " Centre Plate (Flat)	0	2	6
CS168a " Outer Plate	0	2	6
CS169a " Spring Cup	0	3	0
CS171 " Friction Ring with Corks	0	3	0
CS171 " Friction Ring with Fibre Plugs	0	5	0
CS172 " Adjuster Nut	0	0	9
CS173 " End Cap	0	1	6
TS 50 " Back Plate	0	2	6
TS 52a " Spring	0	1	8
TS 56 Friction Plug, $\frac{5}{8}$ in. diameter (Cork)	0	0	5
TS 57 Friction Plug, $\frac{3}{4}$ in. diameter (Cork)	0	0	5

All Communications should be addressed to—
STURMEY-ARCHER GEARS LTD.,
LENTON, NOTTINGHAM.

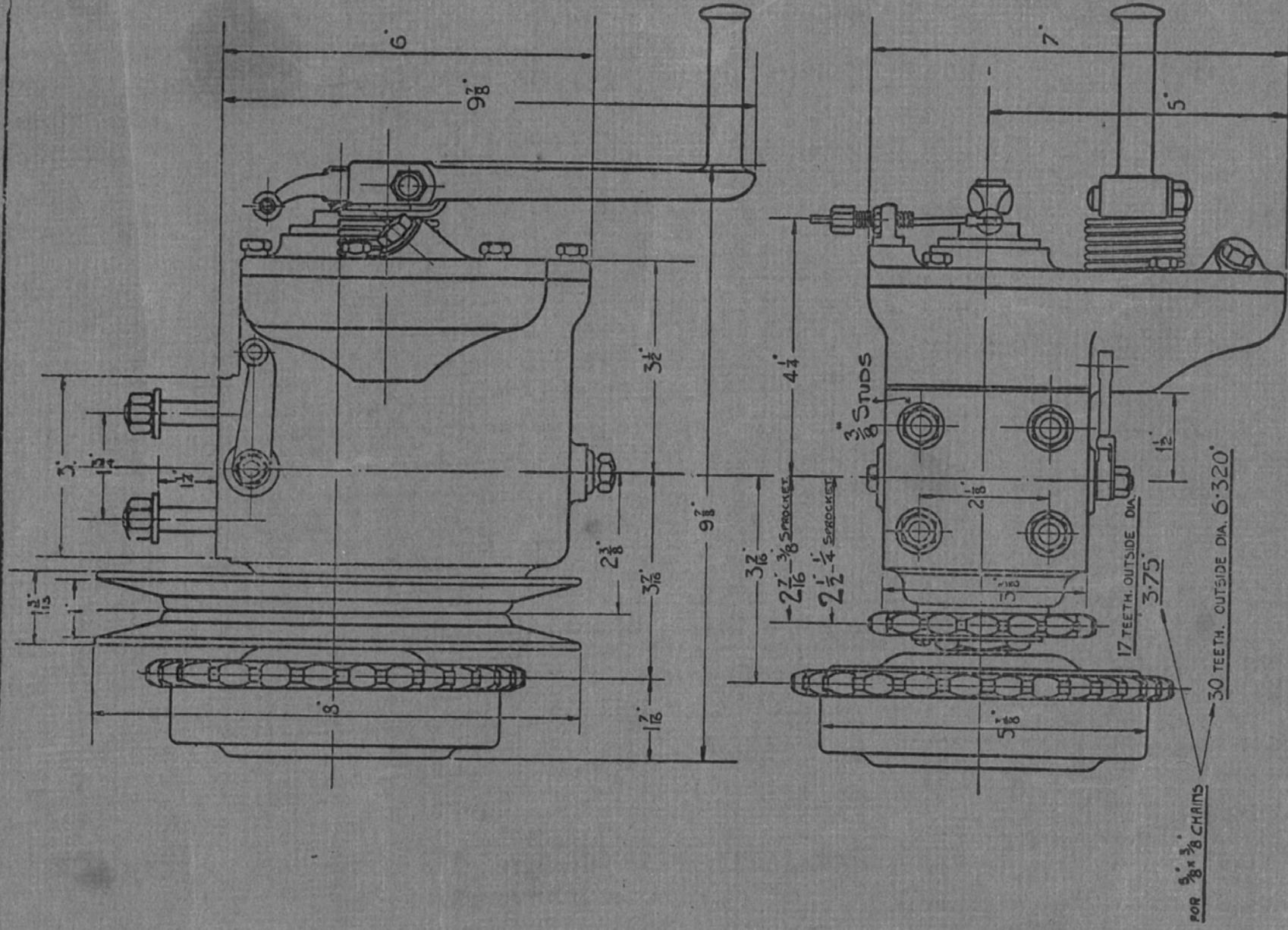

STURMEY-ARCHER 3-SPEED C.S. GEAR

GEAR-RATIOS 1:1.632...2.662 23.120 T.M.M.